

Attachment II

SERVICE AGREEMENT NO. 2843

~~APPENDIX D—PUBLIC POLICY TRANSMISSION PLANNING PROCESS~~

SERVICE AGREEMENT NO. 2843

DEVELOPMENT AGREEMENT

TABLE OF CONTENTS

ARTICLE 1. DEFINITIONS

ARTICLE 2. EFFECTIVE DATE AND TERM

2.1. Effective Date

2.2. Filing

2.3. Term of Agreement

ARTICLE 3. DESIGNATED PROJECT DEVELOPMENT AND CONSTRUCTION

3.1. Application for Required Authorizations and Approvals

3.2. Development and Construction of Designated Project

3.3. Milestones

3.4. Modifications to Required Project In-Service Dates

3.5. Modifications to Designated Project

3.6. Billing and Payment

3.7. Project Monitoring

3.8. Right to Inspect

3.9. Exclusive Responsibility of Designated Entity

3.10. Subcontractors

3.11. No Services or Products Under NYISO Tariffs

3.12. Tax Status

ARTICLE 4. COORDINATION WITH THIRD PARTIES

4.1. Interconnection Requirements for Designated Project

4.2. Interconnection with Affected System

4.3. Coordination of Interregional Transmission Project

ARTICLE 5. OPERATION REQUIREMENTS FOR THE DESIGNATED PROJECT

ARTICLE 6. INSURANCE

ARTICLE 7. BREACH AND DEFAULT

7.1. Breach

7.2. Default

7.3. Remedies

ARTICLE 8. TERMINATION

8.1. Termination by the NYISO

8.2. Reporting of Inability to Comply with Provisions of Agreement

8.3. Designated Project Transfer Rights Upon Termination

ARTICLE 9. LIABILITY AND INDEMNIFICATION

9.1. Liability

9.2. Indemnity

ARTICLE 10. ASSIGNMENT

ARTICLE 11. INFORMATION EXCHANGE AND CONFIDENTIALITY

11.1. Information Access

11.2. Confidentiality

ARTICLE 12. REPRESENTATIONS, WARRANTIES AND COVENANTS

12.1. General

12.2. Good Standing

12.3. Authority

12.4. No Conflict

SERVICE AGREEMENT NO. 2843

~~12.5. Consent and Approval~~

~~12.6. Compliance with All Applicable Laws and Regulations~~

~~ARTICLE 13. DISPUTE RESOLUTION~~

~~ARTICLE 14. SURVIVAL~~

~~ARTICLE 15. MISCELLANEOUS~~

~~15.1. Notices~~

~~15.2. Entire Agreement~~

~~15.3. Cost Recovery~~

~~15.4. Binding Effect~~

~~15.5. Force Majeure~~

~~15.6. Disclaimer~~

~~15.7. No NYISO Liability for Review or Approval of Designated Entity Materials~~

~~15.8. Amendment~~

~~15.9. No Third Party Beneficiaries~~

~~15.10. Waiver~~

~~15.11. Rules of Interpretation~~

~~15.12. Severability~~

~~15.13. Multiple Counterparts~~

~~15.14. No Partnership~~

~~15.15. Headings~~

~~15.16. Governing Law~~

~~15.17. Jurisdiction and Venue~~

Appendices

AMONG

THE NEW YORK INDEPENDENT SYSTEM OPERATOR, INC.

AND

NEW YORK POWER AUTHORITY

AND

NEW YORK TRANSCO LLC

Dated as of May 3, 2024

Table of Contents

<u>ARTICLE 1. DEFINITIONS</u>	<u>2</u>
<u>ARTICLE 2. EFFECTIVE DATE AND TERM</u>	<u>6</u>
<u>2.1. Effective Date</u>	<u>6</u>
<u>2.2. Filing</u>	<u>7</u>
<u>2.3. Term of Agreement.....</u>	<u>7</u>
<u>ARTICLE 3. DESIGNATED PROJECT DEVELOPMENT AND CONSTRUCTION</u>	<u>7</u>
<u>3.1. Application for Required Authorizations and Approvals</u>	<u>7</u>
<u>3.2. Development and Construction of Designated Project.....</u>	<u>7</u>
<u>3.3. Milestones</u>	<u>8</u>
<u>3.4. Modifications to Required Project In-Service Dates</u>	<u>10</u>
<u>3.5. Modifications to Designated Project.....</u>	<u>11</u>
<u>3.6. Billing and Payment.....</u>	<u>12</u>
<u>3.7. Project Monitoring.....</u>	<u>12</u>
<u>3.8. Right to Inspect</u>	<u>12</u>
<u>3.9. Exclusive Responsibility of Designated Entity.....</u>	<u>13</u>
<u>3.10. Subcontractors.....</u>	<u>13</u>
<u>3.12. Tax Status.....</u>	<u>13</u>
<u>3.13 Joint and Several Liability</u>	<u>14</u>
<u>ARTICLE 4. COORDINATION WITH THIRD PARTIES</u>	<u>14</u>
<u>4.1. Interconnection Requirements for Designated Project</u>	<u>14</u>
<u>4.2. Interconnection with Affected System.....</u>	<u>14</u>
<u>4.3. Coordination of Interregional Transmission Project.....</u>	<u>15</u>
<u>ARTICLE 5. OPERATION REQUIREMENTS FOR THE DESIGNATED PROJECT.....</u>	<u>15</u>
<u>ARTICLE 6. INSURANCE</u>	<u>15</u>
<u>ARTICLE 7. BREACH AND DEFAULT</u>	<u>18</u>
<u>7.1. Breach</u>	<u>18</u>
<u>7.2. Default.....</u>	<u>18</u>
<u>7.3. Remedies.....</u>	<u>19</u>
<u>ARTICLE 8. TERMINATION</u>	<u>20</u>
<u>8.1. Termination by the NYISO.....</u>	<u>20</u>
<u>8.2. Reporting of Inability to Comply with Provisions of Agreement.....</u>	<u>20</u>

SERVICE AGREEMENT NO. 2843

8.3. Designated Project Transfer Rights Upon Termination..... 21

ARTICLE 9. LIABILITY AND INDEMNIFICATION 21

9.1. Liability 21

9.2. Indemnity 22

ARTICLE 10. ASSIGNMENT 22

ARTICLE 11. INFORMATION EXCHANGE AND CONFIDENTIALITY 23

11.1. Information Access 23

11.2. Confidentiality 23

ARTICLE 12. REPRESENTATIONS, WARRANTIES AND COVENANTS 24

12.1. General 24

12.2. Good Standing 24

12.3. Authority 24

12.4. No Conflict..... 24

12.5. Consent and Approval..... 25

12.6. Compliance with All Applicable Laws and Regulations 25

ARTICLE 13. DISPUTE RESOLUTION..... 25

ARTICLE 14. SURVIVAL 25

ARTICLE 15. MISCELLANEOUS 25

15.1. Notices 25

15.2. Entire Agreement..... 27

15.3. Cost Recovery 27

15.4. Binding Effect..... 28

15.5. Force Majeure 28

15.6. Disclaimer 29

15.7. No NYISO Liability for Review or Approval of Designated Entity Materials . 29

15.8. Amendment..... 29

15.9. No Third Party Beneficiaries 29

15.10. Waiver..... 29

15.11. Rules of Interpretation 30

15.12. Severability 30

15.13. Multiple Counterparts 30

15.14. No Partnership 30

15.15. Headings 31

SERVICE AGREEMENT NO. 2843

15.16. Governing Law 31
15.17. Jurisdiction and Venue..... 31

APPENDICES

SERVICE AGREEMENT NO. 2843

THIS DEVELOPMENT AGREEMENT (“Agreement”) is made and entered into this 3rd day of 20, May 2024, by and between the New York Power Authority, a ~~corporate description~~ organized and existing municipal instrumentality and a political subdivision of New York (“NYPA”), New York Transco LLC, a non-incumbent transmission owner organized and existing as a limited liability company under the laws of the State/~~Commonwealth of~~ (“Designated Entity of New York (“Transco”), and the New York Independent System Operator, Inc., a not-for-profit corporation organized and existing under the laws of the State of New York (“NYISO”). NYPA and Transco are collectively the “Designated Entity.” Designated Entity or NYISO each may be referred to as a “Party” or collectively referred to as the “Parties.”

RECITALS

WHEREAS, the NYISO administers the Comprehensive System Planning Process (“CSPP”) in the New York Control Area pursuant to the terms set forth in Attachment Y of the NYISO’s Open Access Transmission Tariff (“OATT”), as accepted by the Federal Energy Regulatory Commission (“FERC”);

WHEREAS, as part of the CSPP, the NYISO administers a Public Policy Transmission Planning Process pursuant to which Public Policy Transmission Need(s) are identified; proposed solutions to the identified need(s) are solicited by the NYISO; and the more efficient or cost-effective transmission solution to satisfy the identified need(s) is selected by the NYISO and reported in the NYISO’s Public Policy Transmission Planning Report;

WHEREAS, the NYISO has selected the a Public Policy Transmission Project as the more efficient or cost-effective transmission solution to satisfy an identified Public Policy Transmission Need (“Transmission Project”); has designated the Designated Entity as responsible for developing the Designated Public Policy Project, which constitutes the Transmission Project, or a part of the Transmission Project, as specified in Appendix A, and/or Designated Network Upgrade Facilities designated to the Designated Entity pursuant to Section 22.9.6 of Attachment P to the ISO OATT, as specified in Appendix A (“Designated Project”); and directed the Designated Entity to proceed with the Designated Project;

WHEREAS, the Designated Entity has agreed to obtain the required authorizations and approvals from Governmental Authorities needed for the Designated Project, to develop and construct the Designated Project, and to abide by the related requirements in Attachment Y of the OATT, the ISO Tariffs, and the ISO Procedures;

WHEREAS, the Designated Entity and the NYISO have agreed to enter into this Agreement pursuant to Section 31.4.12.2 of Attachment Y of the OATT for the purpose of ensuring that the Designated Project will be constructed and in service by the required date(s) (“Required Designated Project In-Service Date”) to enable the Transmission Project to be constructed and in-service by the required date to satisfy the Public Policy Transmission Need (“Required Transmission Project In-Service Date”); and

WHEREAS, the Designated Entity has agreed to construct, and the NYISO has requested that the Designated Entity proceed with construction of, the Designated Project to provide for the Designated Project to be in-service by the Required Designated Project In-Service Date(s).

NOW, THEREFORE, in consideration of and subject to the mutual covenants contained herein, it is agreed:

ARTICLE 1. DEFINITIONS

Whenever used in this Agreement with initial capitalization, the following terms shall have the meanings specified in this Article 1. Terms used in this Agreement with initial capitalization that are not defined in this Article 1 shall have the meanings specified in Section 31.1.1 of Attachment Y of the OATT or, if not therein, in Article 1 of the OATT.

Advisory Milestones shall mean the milestones set forth in the Development Schedule in Attachment C to this Agreement that are not Critical Path Milestones.

Affected System Operator shall mean any Affected System Operator(s) identified in connection with the Designated Project pursuant to Attachment P of the ISO OATT.

Applicable Laws and Regulations shall mean: (i) all duly promulgated applicable federal, state and local laws, regulations, rules, ordinances, codes, decrees, judgments, directives, or judicial or administrative orders, permits and other duly authorized actions of any Governmental Authority, and (ii) all applicable requirements of the ISO Tariffs, ISO Procedures, and ISO Related Agreements.

Applicable Reliability Organizations shall mean the NERC, the NPCC, and the NYSRC.

Applicable Reliability Requirements shall mean the requirements, criteria, rules, standards, and guidelines, as they may be amended and modified and in effect from time to time, of: (i) the Applicable Reliability Organizations, (ii) the Connecting Transmission Owner(s), (iii) ~~*to insert the name(s) of any other Transmission Owners or developers whose transmission facilities the NYISO has determined may be impacted by the Designated Project*~~, Consolidated Edison Company of New York, Inc., Long Island Power Authority, and NYPA, and (iv) any Affected System Operator; *provided, however*, that no Party shall waive its right to challenge the applicability or validity of any requirement, criteria, rule, standard, or guideline as applied to it in the context of this Agreement.

Breach shall have the meaning set forth in Article 7.1 of this Agreement.

Breaching Party shall mean a Party that is in Breach of this Agreement.

Business Day shall mean Monday through Friday, excluding federal holidays.

Calendar Day shall mean any day including Saturday, Sunday, or a federal holiday.

Change of Control shall mean a change in ownership of more than 50% of the membership or ownership interests or other voting securities of ~~the Designated Entity~~ either NYPA or Transco to a third party in one or more related transactions, or any other transaction that has the effect of transferring control of ~~the Designated Entity~~ NYPA or Transco to a third party.

Confidential Information shall mean any information that is defined as confidential by Article 11.2.

Connecting Transmission Owner shall be the Connecting Transmission Owner(s) identified in connection with the Designated Project pursuant to Attachment P of the ISO OATT.

Critical Path Milestones shall mean the milestones identified as such in the Development Schedule in Attachment C to this Agreement that must be met for the Designated Project to be constructed and operating by the Required Designated Project In-Service Date.

Default shall mean the failure of a Party in Breach of this Agreement to cure such Breach in accordance with Article 7.2 of this Agreement.

Designated Entity shall have the meaning set forth in the introductory paragraph.

Designated Network Upgrade Facilities shall mean the Network Upgrade Facilities identified through the Transmission Interconnection Procedures for a Public Policy Transmission Project selected under Attachment Y to the ISO OATT; that meet the definition of upgrade under Section 31.6.4 of Attachment Y to the ISO OATT; and that are designated to the Connecting Transmission Owner or Affected Transmission Owner in accordance with Section 22.9.6 of Attachment P to the ISO OATT, as described in the Project Description set forth in Appendix A to this Agreement.

Designated Project shall mean the Designated Public Policy Project that the Designated Entity has been designated to develop and place into service pursuant to Section 31.4.11 of Attachment Y and the Designated Network Upgrade Facilities that the Designated Entity has been designated to develop and place into service pursuant Section 22.9.6 of Attachment P to the ISO OATT, as described in the Project Description set forth in Appendix A to this Agreement.

Development Schedule shall mean the schedule of Critical Path Milestones and Advisory Milestones set forth in Appendix C to this Agreement.

Effective Date shall mean the date upon which this Agreement becomes effective as determined in Article 2.1 of this Agreement.

FERC shall mean the Federal Energy Regulatory Commission or its successor.

Force Majeure shall mean any act of God, labor disturbance, act of the public enemy, war, insurrection, riot, fire, storm or flood, explosion, breakage or accident to machinery or equipment, any order, regulation or restriction imposed by governmental, military or lawfully established civilian authorities, or any other cause beyond a Party's control. A Force Majeure event does not include acts of negligence or intentional wrongdoing by the Party claiming Force Majeure.

Good Utility Practice shall mean any of the practices, methods and acts engaged in or approved by a significant portion of the electric industry during the relevant time period, or any of the practices, methods and acts which, in the exercise of reasonable judgment in light of the facts known at the time the decision was made, could have been expected to accomplish the desired

SERVICE AGREEMENT NO. 2843

result at a reasonable cost consistent with good business practice, reliability, safety and expedition. Good Utility Practice is not intended to be limited to the optimum practice, method, or act to the exclusion of all others, but rather to delineate acceptable practices, methods, or acts generally accepted in the region.

Governmental Authority shall mean any federal, state, local or other governmental regulatory or administrative agency, public authority, court, commission, department, board, or other governmental subdivision, legislature, rulemaking board, tribunal, or other governmental authority having jurisdiction over any of the Parties, their respective facilities, or the respective services they provide, and exercising or entitled to exercise any administrative, executive, police, or taxing authority or power; *provided, however*, that such term does not include the NYISO, the Designated Entity, the Connecting Transmission Owner(s), the Affected System Operator(s), or any Affiliate thereof.

In-Service Date shall mean the date upon which the Designated Project is energized consistent with the provisions of the Transmission Project Interconnection Agreement for the Designated Project and available to provide Transmission Service under the NYISO Tariffs.

ISO/TO Agreement shall mean the *Agreement Between the New York Independent System Operator and Transmission Owners*, as filed with and accepted by the Commission in *Cent. Hudson Gas & Elec. Corp., et al.*, 88 FERC ¶ 61,138 (1999) in Docket Nos. ER97-1523, *et al.*, and as amended or supplemented from time to time, or any successor agreement thereto.

New York State Transmission System shall mean the entire New York State electrical transmission system, which includes: (i) the Transmission Facilities Under ISO Operational Control; (ii) the Transmission Facilities Requiring ISO Notification; and (iii) all remaining transmission facilities within the New York Control Area.

NERC shall mean the North American Electric Reliability Corporation or its successor organization.

NPCC shall mean the Northeast Power Coordinating Council or its successor organization.

NYPSC shall mean the New York State Public Service Commission or its successor.

NYSRC shall mean the New York State Reliability Council or its successor organization.

OATT shall mean the NYISO's Open Access Transmission Tariff, as filed with the Commission, and as amended or supplemented from time to time, or any successor tariff thereto.

Party or Parties shall ~~mean~~have the NYISO, meaning set forth in the Designated Entity, or both introductory paragraph.

Point of Interconnection shall mean the point or points at which the Designated Entity's Designated Project will interconnect to the New York State Transmission System.

Project Description shall mean the description of the Designated Project set forth in Appendix A to this Agreement for which the Designated Entity was designated to develop and place into

service and (i) that is consistent with the Designated Project component of the Transmission Project proposed and evaluated in the NYISO's Public Policy Transmission Planning Process and selected by the NYISO Board of Directors as the more efficient or cost-effective transmission solution to the identified Public Policy Transmission Need and/or (ii) that is consistent with the Designated Network Upgrade Facilities identified for the Transmission Project in a NYISO-conducted Facilities Study under Attachment P to the ISO OATT.

Public Policy Transmission Planning Process Manual shall mean the NYISO's manual adopted by the NYISO stakeholder Operating Committee describing the NYISO's procedures for implementing the Public Policy Transmission Planning Process component of the NYISO's Comprehensive System Planning Process, as the manual is amended or supplemented from time to time, or any successor manual thereto.

Required Designated Project In-Service Date shall mean the in-service date or dates by which the Designated Project must be constructed and operating, which date(s) will be identified by the NYISO as either: (A) the in-service date specified by the Developer in the project information it submitted under Attachment Y for one or more of the components of the Designated Project for use by the NYISO in its selection of the Transmission Project as the more efficient or cost-effective transmission solution to satisfy the Public Policy Transmission Need, or (B) such other date accepted by the NYISO for one or more of the components of the Designated Project as reasonable in light of the Public Policy Transmission Need. The Required Designated Project In-Service Date may be the same date as or an earlier date or dates than the Required Transmission Project In-Service Date. The Required Designated Project In-Service Date is set forth in the Development Schedule contained in Appendix C to this Agreement.

Required Transmission Project In-Service Date shall mean the in-service date by which the Transmission Project, including all Designated Public Policy Projects that constitute the Transmission Project and Designated Network Upgrade Facilities identified for the Transmission Project (if applicable), must be constructed and operating, which date shall be: (i) the date by which the Public Policy Transmission Need must be satisfied as prescribed by the NYPSC in its order identifying the need or in a subsequent order, or (ii) if the NYPSC has not prescribed a date, the date proposed by the Developer in the project information submittal for the Transmission Project and reviewed and accepted by the NYISO, which date may be either: (A) the in-service date specified by the Developer in the project information it submitted under Attachment Y of the OATT for use by the NYISO in its selection of the Transmission Project as the more efficient or cost-effective transmission solution to satisfy the Public Policy Transmission Need, or (B) such other date accepted by the NYISO as reasonable in light of the Public Policy Transmission Need. The Required Transmission Project In-Service Date is set forth in the Development Schedule contained in Appendix C to this Agreement.

Services Tariff shall mean the NYISO's Market Administration and Control Area Services Tariff, as filed with the Commission, and as amended or supplemented from time to time, or any successor tariff thereto.

Significant Modification shall mean a Designated Entity's proposed modification to its Designated Project that: (i) could impair the Transmission Project's or Designated Project's ability to meet the identified Public Policy Transmission Need, (ii) could delay the In-Service

Date of the Transmission Project or Designated Project beyond the Required Transmission Project In-Service Date or Required Designated Project In-Service Date, respectively, or (iii) would constitute a material change to the project information submitted by the Developer under Attachment Y of the OATT for use by the NYISO in evaluating the Transmission Project for purposes of selecting the more efficient or cost-effective transmission solution to meet the identified Public Policy Transmission Need.

Scope of Work shall mean the description of the work required to implement the Designated Project as set forth in Appendix B to this Agreement. The Scope of Work shall be drawn from the Developer's submission of the "Information for a Proposed Solution to a Public Policy Transmission Need" and the "Data Submission for Public Policy Transmission Projects," which are set forth in Attachments B and C of the NYISO Public Policy Transmission Planning Process Manual, as may be updated as agreed upon by the Parties. The Scope of Work shall include, but not be limited to, a description of: the acquisition of required rights-of-ways, the work associated with the licensing, design, financing, environmental and regulatory approvals, engineering, procurement of equipment, construction, installation, testing, and commissioning of the Designated Project; the relevant technical requirements, standards, and guidelines pursuant to which the work will be performed; the major equipment and facilities to be constructed and/or installed in connection with the Designated Project, and the cost estimates for the work associated with the Designated Project.

Transmission Owner Technical Standards shall mean the technical requirements and standards (e.g. equipment or facilities electrical and physical capabilities, design characteristics, or construction requirements), as those requirements and standards are amended and modified and in effect from time to time, of: (i) the Connecting Transmission Owner(s), (ii) ~~to insert the name(s) Consolidated Edison Company of any other Transmission Owners, other Designated Entities, or developers whose transmission facilities the NYISO has determined may be impacted by the Designated Project~~; New York, Inc., Long Island Power Authority, and NYPA, and (iii) any Affected System Operator.

Transmission Project shall mean a Public Policy Transmission Project selected by the NYISO as the more efficient or cost-effective transmission solution to a Public Policy Transmission Need. The Designated Project subject to this Agreement shall be the Transmission Project, or the part of the Transmission Project, designated to the Designated Entity pursuant to Section 31.4.11 of Attachment Y.

ARTICLE 2. EFFECTIVE DATE AND TERM

2.1. Effective Date

This Agreement shall become effective on the date it has been executed by all Parties; *provided, however*, if the Agreement is filed with FERC as a non-conforming or an unexecuted agreement pursuant to Section 31.4.12.2 of Attachment Y of the OATT, the Agreement shall become effective on the effective date accepted by FERC.

2.2. Filing

If the Agreement must be filed with FERC pursuant to Section 31.4.12.2 of Attachment Y of the OATT, the NYISO shall file this Agreement for acceptance with FERC within the timeframe set forth for the filing in Section 31.4.12.2 of Attachment Y of the OATT. The Designated Entity shall cooperate in good faith with the NYISO with respect to such filing and provide any information requested by the NYISO to comply with Applicable Laws and Regulations. Any Confidential Information shall be treated in accordance with Article 11.2 of this Agreement.

2.3. Term of Agreement

Subject to the termination provisions in Article 8 of this Agreement, this Agreement shall remain in effect from the Effective Date until: (i) ~~the Designated Entity executes~~NYPA and Transco each has executed an operating agreement with the NYISO, or is a party to the ISO/TO Agreement, as applicable, and (ii) the Designated Project: (A) has been completed in accordance with the terms and conditions of this Agreement, and (B) is in-service; *provided, however*, that the terms of this Agreement shall continue in effect to the extent provided in Article 14 of this Agreement.

ARTICLE 3. DESIGNATED PROJECT DEVELOPMENT AND CONSTRUCTION

3.1. Application for Required Authorizations and Approvals

The Designated Entity shall timely seek and obtain all authorizations and approvals from Governmental Authorities required to develop, construct, and operate the Designated Project by the Required Designated Project In-Service Date. The required authorizations and approvals shall be listed in the Scope of Work in Appendix B to this Agreement. The Designated Entity shall seek and obtain the required authorizations and approvals in accordance with the milestones set forth in the Development Schedule in Appendix C to this Agreement. The milestones for obtaining the required authorizations and approvals shall be included in the Development Schedule as Critical Path Milestones and Advisory Milestones, as designated by the Parties under Article 3.3.1. The Designated Entity shall notify the NYISO in accordance with the notice requirements in Article 3.3 if it has reason to believe that it may be unable to timely obtain or is denied an approval or authorization by a Governmental Authority required for the development, construction, or operation of the Designated Project, or if such approval or authorization is withdrawn or modified.

3.2. Development and Construction of Designated Project

The Designated Entity shall design, engineer, procure, install, construct, test and commission the Designated Project in accordance with: (i) the terms of this Agreement, including, but not limited to, the Project Description in Appendix A to this Agreement, the Scope of Work in Appendix B to this Agreement, and the Development Schedule in Appendix C to this Agreement; (ii) Applicable Reliability Requirements; (iii) Applicable Laws and Regulations; (iv) Good Utility Practice; (v) the Transmission Owner Technical Standards, (vi) any interconnection agreement(s) entered into by and among the NYISO, Designated Entity, and Connecting Transmission Owner(s) for the Designated Project to interconnect to the New York State

Transmission System, and (v) any engineering, procurement, and construction (“EPC”) agreement(s) associated with the interconnection of the Designated Project to the New York State Transmission System.

3.3. Milestones

- 3.3.1. The NYISO shall provide the Designated Entity with the Required Transmission Project In-Service Date and Required Designated Project In-Service Date that is set forth in the Public Policy Transmission Planning Report in accordance with Section 31.4.11 of Attachment Y of the OATT and the estimated time to construct Designated Network Upgrade Facilities contained in the NYISO-conducted Facilities Study report. Prior to executing and/or filing this Agreement with FERC, the NYISO and the Designated Entity shall agree to the Critical Path Milestones and Advisory Milestones set forth in the Development Schedule in Appendix C to this Agreement for the development, construction, and operation of the Designated Project to allow the Designated Project to go into service by the Required Designated Project In-Service Date in accordance with Section 31.4.12.2 of Attachment Y of the OATT; provided that any such milestone for the Designated Project that requires action by a Designated Entity of another Designated Public Policy Project or Designated Network Upgrade Facilities related to the Transmission Project, a Connecting Transmission Owner, or an Affected System Operator to complete must be included as an Advisory Milestone.
- 3.3.2. The Designated Entity shall meet the Critical Path Milestones in accordance with the Development Schedule set forth in Appendix C to this Agreement. The Designated Entity’s inability or failure to meet a Critical Path Milestone specified in the Development Schedule, as such Critical Path Milestone may be amended with the agreement of the NYISO under this Article 3.3, shall constitute a Breach of this Agreement under Article 7.1.
- 3.3.3. The Designated Entity shall notify the NYISO thirty (30) Calendar Days prior to the date of each Critical Path Milestone specified in the Development Schedule whether, to the best of its knowledge, it expects to meet the Critical Path Milestone by the specified date; *provided, however*, that notwithstanding this requirement:
- (i) the Designated Entity shall notify the NYISO as soon as reasonably practicable, and no later than fifteen (15) Calendar Days, following ~~the Designated Entity’s~~ either NYPA’s or Transco’s discovery of a potential delay in meeting a Critical Path Milestone, including a delay caused by a Force Majeure event; and
 - (ii) the NYISO may request in writing at any time, and Designated Entity shall submit to the NYISO within five (5) Business Days of the request, a written response indicating whether the Designated Entity will meet, or has met, a Critical Path Milestone and providing all required supporting documentation for its response.
- 3.3.4. The Designated Entity shall not make a change to a Critical Path Milestone without the prior written consent of the NYISO. To request a change to a Critical Path

Milestone, the Designated Entity must: (i) inform the NYISO in writing of the proposed change to the Critical Path Milestone and the reason for the change, including the occurrence of a Force Majeure event in accordance with Section 15.5, (ii) submit to the NYISO a revised Development Schedule containing any necessary changes to Critical Path Milestones and Advisory Milestones that provide for the Designated Project to be completed and achieve its In-Service Date no later than the Required Designated Project In-Service Date, (iii) submit an officer's certificate in a form acceptable to the NYISO certifying the Designated Entity's capability to complete the Designated Project in accordance with the modified schedule taking into account the schedule for completing any other Designated Public Policy Projects or Designated Network Upgrade Facilities related to the Transmission Project, and (iv) submit an officer's certificate in a form acceptable to the NYISO from any other Designated Entity responsible for developing Designated Public Policy Projects or Designated Network Upgrade Facilities related to the Transmission Project certifying its capability to complete its Designated Public Policy Project or Designated Network Upgrade Facilities in accordance with the modified schedule for the Designated Project, if applicable. If the Designated Entity: (i) must notify the NYISO of a potential delay in meeting a Critical Path Milestone in accordance with one of the notification requirements in Section 3.3.3 or (ii) is requesting a change to a Critical Path Milestone to cure a Breach in Section 7.2, the Designated Entity shall submit any request to change the impacted Critical Path Milestone(s) within the relevant notification timeframe set forth in Section 3.3.3 or the cure period set forth in Section 7.2, as applicable. The NYISO will promptly review the Designated Entity's requested change. The Designated Entity shall provide the NYISO with all required information to assist the NYISO in making its determination and shall be responsible for the costs of any study work the NYISO performs in making its determination. If the Designated Entity demonstrates to the NYISO's satisfaction that the delay in meeting a Critical Path Milestone: (i) will not delay the In-Service Date of the Designated Project beyond the Required Designated Project In-Service Date and (ii) will not materially affect the completion of any other Designated Public Policy Project or Designated Network Upgrade Facilities related to the Transmission Project being developed by another Designated Entity by any required in-service date for the other Designated Public Policy Project or Designated Network Upgrade Facilities and/or the Required Transmission Project In-Service Date, if applicable, then the NYISO's consent to extending the Critical Path Milestone date will not be unreasonably withheld, conditioned, or delayed. The NYISO's written consent to a revised Development Schedule proposed by the Designated Entity will satisfy the amendment requirements in Article 15.8, and the NYISO will not be required to file the revised Development Schedule with FERC.

- 3.3.5. Within fifteen (15) Calendar Days of ~~the Designated Entity's~~ either NYPA's or Transco's discovery of a potential delay in meeting an Advisory Milestone, the Designated Entity shall inform the NYISO of the potential delay and describe the impact of the delay on meeting the Critical Path Milestones. The Designated Entity may extend an Advisory Milestone date upon informing the NYISO of such change; *provided, however*, that if the change to the Advisory Milestone will delay a Critical

Path Milestone, the NYISO's written consent to make such change is required as described in Article 3.3.4.

- 3.3.6. In the event that another Designated Entity of a Designated Public Policy Project or Designated Network Upgrade Facilities related to the same Transmission Project seeks to modify its schedule, the Designated Entity subject to this Agreement will not unreasonably withhold, condition, or delay any required input, information, or certification.

3.4. Modifications to Required Project In-Service Dates

- 3.4.1. The Designated Entity shall not make a change to the Required Transmission Project In-Service Date or Required Designated Project In-Service Date without the prior written consent of the NYISO. To request a change, the Designated Entity must: (i) inform the NYISO in writing of the proposed change to the Required Transmission Project In-Service Date or Required Designated Project In-Service Date and the reason for the change, including the occurrence of a Force Majeure event, (ii) submit to the NYISO a revised Development Schedule that provides for the Designated Project and the Transmission Project to be completed and achieve its In-Service Date no later than the proposed, modified Required Designated Project In-Service Date and Required Transmission Project In-Service Date, respectively, taking into account the schedule for completing other Designated Public Policy Projects or Designated Network Upgrade Facilities related to the Transmission Project, if applicable, (iii) demonstrate that the Designated Entity has made reasonable progress against the milestones set forth in the Development Schedule, and is capable of completing the Designated Project in accordance with the modified schedule, and (iv) submit a an officer's certificate in a form acceptable to the NYISO from other Designated Entities responsible for developing Designated Public Policy Projects or Designated Network Upgrade Facilities related to the Transmission Project certifying their capability to complete their projects in accordance with the Designated Entity's modified schedule and the proposed, modified Required Transmission Project In-Service Date and/or Required Designated Project In-Service Date. If the Required Transmission Project In-Service Date is the date prescribed by the NYPSC in its order identifying the Public Policy Transmission Need or in a subsequent order, the Designated Entity must also demonstrate that the NYPSC has issued an order modifying its prescribed date.
- 3.4.2. The NYISO will promptly review Designated Entity's requested change to the Required Transmission Project In-Service Date and/or Required Designated Project In-Service Date. The Designated Entity shall provide the NYISO with all required information to assist the NYISO in making its determination and shall be responsible for the costs of any study work the NYISO performs in making its determination. If the Designated Entity fails to provide the NYISO with the information required to make its determination, the NYISO shall not be obligated to make this determination. The NYISO's consent to extend the Required Transmission Project In-Service Date and/or Required Designated Project In-Service Date will not be unreasonably withheld, conditioned, or delayed if the Designated Entity demonstrates to the NYISO's satisfaction that: (i) its proposed modified Required Transmission Project

In-Service Date or Required Designated Project In-Service Date is reasonable in light of the Public Policy Transmission Need, (ii) it has made reasonable progress against the milestones set forth in the Development Schedule, (iii) its proposed modified date will not result in a significant adverse impact to the reliability of the New York State Transmission System, and (iv) its proposed modified date will not materially impact the development of Designated Public Policy Projects or Designated Network Upgrade Facilities related to the Transmission Project being developed by other Designated Entities. The Parties shall amend this Agreement in accordance with Article 15.8 to incorporate a revised Required Project In-Service Date and Development Schedule.

3.4.3 In the event that another Designated Entity of a Designated Public Policy Project or Designated Network Upgrade Facilities related to the same Transmission Project seeks to modify its project, its project's Required Designated Project In-Service Date, or the Required Transmission Project In-Service Date, the Designated Entity subject to this Agreement will not unreasonably withhold, condition, or delay any required input, information, or certification.

3.5. Modifications to Designated Project

The Designated Entity shall not make a Significant Modification to the Designated Project without the prior written consent of the NYISO, including, but not limited to, modifications necessary for the Designated Entity to obtain required approvals or authorizations from Governmental Authorities; *provided, however*, that a proposed Significant Modification that is a proposed modification to the Required Transmission Project In-Service Date or Required Designated Project In-Service Date shall be addressed in accordance with Article 3.4. The NYISO's determination regarding a Significant Modification to the Designated Project under this Agreement shall be separate from, and shall not replace, the NYISO's review and determination of material modifications to the Designated Project under Attachment P of the OATT. The Designated Entity may request that the NYISO review whether a modification to the Designated Project would constitute a Significant Modification. The Designated Entity shall provide the NYISO with all required information to assist the NYISO in making its determination regarding a Significant Modification and shall be responsible for the costs of any study work the NYISO must perform in making its determination. The NYISO's consent to the Significant Modification will not be unreasonably withheld, conditioned, or delayed if the Designated Entity demonstrates to the NYISO's satisfaction that its proposed Significant Modification: (i) does not impair the Transmission Project's ability to satisfy the identified Public Policy Transmission Need, (ii) does not delay the In-Service Date of the Transmission Project or Designated Project beyond the Required Transmission Project In-Service Date or Required Designated Project In-Service Date, respectively, (iii) does not change the grounds upon which the NYISO selected the Transmission Project as the more efficient or cost-effective transmission solution to the identified Public Policy Transmission Need, (iv) will not result in a significant adverse impact to the reliability of the New York State Transmission System, and (v) through submittal of an officer's certificate in a form acceptable to the NYISO from other Designated Entities responsible for developing Designated Public Policy Projects or Designated Network Upgrade Facilities related to the Transmission Project, certifies that the proposed modification will not materially impact the development of such other Designated Public Policy

Projects or Designated Network Upgrade Facilities. The NYISO's performance of this review shall not constitute its consent to delay the completion of any Critical Path Milestone.

3.6. Billing and Payment

The NYISO shall charge, and the Designated Entity shall pay, the actual costs of: (i) any study work performed by the NYISO or its subcontractor(s) under Articles 3.3, 3.4, and 3.5, or (ii) any assessment of the Designated Project by the NYISO or its subcontractor(s) under Article 3.8. NYPA and Transco shall identify a single billing and payment contact for the Designated Entity, and the NYISO will invoice the Designated Entity by sending invoices to that billing and payment contact at the notice address for such contact set forth in Article 15.1. The NYISO will invoice Designated Entity by sending invoices to the billing and payment contact on a monthly basis for the expenses incurred by the NYISO each month, including estimated subcontractor costs, computed on a time and material basis. The NYISO shall not be required to allocate charges to the Designated Entity between NYPA and Transco. NYPA and Transco shall resolve between themselves how such charges shall be allocated between themselves. The Designated Entity shall pay invoiced amounts to the NYISO within thirty (30) Calendar Days of the NYISO's issuance of a monthly invoice. In the event the Designated Entity disputes an amount to be paid, the Designated Entity shall pay the disputed amount to the NYISO, pending resolution of the dispute. To the extent the dispute is resolved in the Designated Entity's favor, the NYISO will net the disputed amount, including interest calculated from Designated Entity's date of payment at rates applicable to refunds under FERC regulations, against any current amounts due from the Designated Entity and pay the balance to the Designated Entity. This Article 3.6 shall survive the termination, expiration, or cancellation of this Agreement.

3.7. Project Monitoring

The Designated Entity shall provide regular status reports to the NYISO in accordance with the monitoring requirements set forth in the Development Schedule, the Public Policy Transmission Planning Process Manual and Attachment Y of the OATT. The Designated Entity shall also provide updates and information upon the NYISO's request to assist with the coordination of the Designated Project with other Designated Public Policy Projects or Designated Network Upgrade Facilities related to the Transmission Project.

3.8. Right to Inspect

Upon reasonable notice, the NYISO or its subcontractor shall have the right to inspect the Designated Project for the purpose of assessing the progress of the development and construction of the Designated Project and satisfaction of milestones. The exercise or non-exercise by the NYISO or its subcontractor of this right shall not be construed as an endorsement or confirmation of any element or condition of the development or construction of the Designated Project, or as a warranty as to the fitness, safety, desirability or reliability of the same. Any such inspection shall take place during normal business hours, shall not interfere with the construction of the Designated Project and shall be subject to such reasonable safety and procedural requirements as the Designated Entity shall specify.

3.9. Exclusive Responsibility of Designated Entity

As between the Parties, the Designated Entity shall be solely responsible for all planning, design, engineering, procurement, construction, installation, management, operations, safety, and compliance with Applicable Laws and Regulations, Applicable Reliability Requirements, and Transmission Owner Technical Standards associated with the Designated Project, including, but not limited to, scheduling, meeting Critical Path Milestones and Advisory Milestones, timely requesting review and consent to any project modifications, and obtaining all necessary permits, siting, and other regulatory approvals. The NYISO shall have no responsibility and shall have no liability regarding the management or supervision of the Designated Entity's development of the Designated Project or the compliance of the Designated Entity with Applicable Laws and Regulations, Applicable Reliability Requirements, and Transmission Owner Technical Standards. The NYISO shall cooperate with the Designated Entity in good faith in providing information to assist the Designated Entity in obtaining all approvals and authorizations from Governmental Authorities required to develop, construct, and operate the Designated Project by the Required Designated Project In-Service Date, including, if applicable, information describing the NYISO's basis for selecting the Transmission Project as the more efficient or cost-effective transmission solution to satisfy an identified Public Policy Transmission Need.

3.10. Subcontractors

- 3.10.1. Nothing in this Agreement shall prevent a Party from using the services of any subcontractor as it deems appropriate to perform its obligations under this Agreement; *provided, however*, that each Party shall require, and shall provide in its contracts with its subcontractors, that its subcontractors comply with all applicable terms and conditions of this Agreement in providing such services; *provided, further*, that each Party shall remain primarily liable to the other Party for the performance of such subcontractor.
- 3.10.2. The creation of any subcontractor relationship shall not relieve the hiring Party of any of its obligations under this Agreement. The hiring Party shall be fully responsible to the other Party for the acts or omissions of any subcontractor the hiring Party hires as if no subcontract had been made.

3.11. No Services or Products Under NYISO Tariffs

This Agreement does not constitute a request for, nor agreement by the NYISO to provide, Transmission Service, interconnection service, Energy, Ancillary Services, Installed Capacity, Transmission Congestion Contracts or any other services or products established under the ISO Tariffs. If Designated Entity wishes to receive or supply such products or services, the Designated Entity must make application to do so under the applicable provisions of the ISO Tariffs, ISO Related Agreements, and ISO Procedures.

3.12. Tax Status

Each Party shall cooperate with the other Party to maintain each Party's tax status to the extent the Party's tax status is impacted by this Agreement. Nothing in this agreement is intended to affect the tax status of any Party.

3.13 Joint and Several Liability

NYPA and Transco are jointly and severally liable for all obligations of the Designated Entity under this Agreement.

ARTICLE 4. COORDINATION WITH THIRD PARTIES

4.1. Interconnection Requirements for Designated Project

The Designated Entity shall satisfy all requirements set forth in the Transmission Interconnection Procedures in Attachment P of the OATT applicable to a “Transmission Project” to interconnect the Designated Project to the New York State Transmission System by the Required Designated Project In-Service Date, including, but not limited to, submitting a Transmission Interconnection Application for the Designated Project or joining with the agreement of the “Transmission Developer” a pending Transmission Interconnection Application that includes the Designated Project; participating in all necessary studies; executing, and/or requesting the NYISO to file for FERC acceptance, a Transmission Project Interconnection Agreement for the Designated Project and/or EPC agreement(s), as applicable; and constructing, or arranging for the construction of, all required Network Upgrade Facilities; *provided, however*, if a Developer began the interconnection process in Attachment X of the OATT or the transmission expansion process in Sections 3.7 or 4.5 of the OATT for the Transmission Project prior to the effective date of the Transmission Interconnection Procedures, the Designated Entity shall satisfy the requirements of the Transmission Interconnection Procedures in accordance with the transition rules in Section 22.3.3 of Attachment P of the OATT.

If the NYISO determines that the proposed interconnection of a “Transmission Project” under Attachment P could affect the Designated Project under this Agreement, the Designated Entity shall participate in the Transmission Interconnection Procedures as an Affected System Operator in accordance with the requirements set forth in Section 22.4.4 of Attachment P. If the NYISO determines that the proposed interconnection of a “Large Generating Facility,” “Small Generating Facility,” or “Class Year Transmission Project” under Attachments X or Z of the OATT could affect the Designated Project, the Designated Entity shall participate in the interconnection process as an Affected System Operator in accordance with the requirements set forth in Section 30.3.5 of Attachment X of the OATT. If the NYISO determines that a proposed transmission expansion under Sections 3.7 and 4.5 of the OATT could affect the Designated Project, the Designated Entity shall participate in the transmission expansion process as an affected Transmission Owner in accordance with the requirements set forth in Sections 3.7 and 4.5 of the OATT.

4.2. Interconnection with Affected System

If part of the Designated Project will affect the facilities of an Affected System as determined in Attachment P of the OATT, the Designated Entity shall satisfy the requirements of the Affected System Operator for the interconnection of the Designated Project, including entering into any applicable EPC agreement(s).

4.3. Coordination of Interregional Transmission Project

If the Transmission Project is or seeks to become an Interregional Transmission Project selected by the NYISO and by the transmission provider in one or more neighboring transmission planning region(s) to address an identified Public Policy Transmission Need, the Designated Entity shall coordinate its development and construction of the Designated Project in New York with its responsibilities in the relevant neighboring transmission planning region(s) and must satisfy the applicable planning requirements of the relevant transmission planning region(s).

ARTICLE 5. OPERATION REQUIREMENTS FOR THE DESIGNATED PROJECT

If the Designated Entity is a Transmission Owner, the Designated Entity shall comply with the operating requirements set forth in the ISO/TO Agreement: or an executed operating agreement with the NYISO. If the Designated Entity is not a Transmission Owner that does not have an executed operating agreement with the NYISO, the Designated Entity shall: (i) execute, and/or obtain a FERC accepted, interconnection agreement for the Designated Project in accordance with the requirements in Attachment P of the OATT; (ii) satisfy the applicable requirements set forth in the interconnection agreement and ISO Procedures for the safe and reliable operation of the Designated Project consistent with the Project Description set forth in Appendix A by the In-Service Date, including satisfying all applicable testing, metering, communication, system protection, switching, start-up, and synchronization requirements; (iii) enter into required operating protocols as determined by the NYISO; (iv) register with NERC as a Transmission Owner, be certified as a Transmission Operator unless otherwise agreed by the Parties, and comply with all NERC Reliability Standards and Applicable Reliability Requirements applicable to Transmission Owners and Transmission Operators; and (v) prior to energizing the Designated Project, execute an operating agreement with the NYISO.

ARTICLE 6. INSURANCE

~~The Designated Entity~~ NYPA and Transco shall each, at ~~its~~their own expense, maintain in force throughout the period of this Agreement, and until released by the NYISO, the following minimum insurance coverages, with insurers authorized to do business in the state of New York and rated “A- (minus) VII” or better by A.M. Best & Co. (or if not rated by A.M. Best & Co., a rating entity acceptable to the NYISO):

- 6.1** Workers’ Compensation and Employers’ Liability Insurance providing statutory benefits in accordance with the laws and regulations of New York State under NCCI Coverage Form No. WC 00 00 00, as amended or supplemented from time to time, or an equivalent form acceptable to the NYISO; *provided, however*, if the Designated Project will be located in part outside of New York State, Designated Entity NYPA and Transco shall each maintain such Employers’ Liability Insurance coverage with a minimum limit of One Million Dollars (\$1,000,000).
- 6.2** Commercial General Liability Insurance – under ISO Coverage Form No. CG 00 01 (04/13), as amended or supplemented from time to time, or an equivalent form acceptable to the NYISO – with minimum limits of Two Million Dollars (\$2,000,000)

SERVICE AGREEMENT NO. 2843

per occurrence/Four Million Dollars (\$4,000,000) aggregate combined single limit for personal injury, bodily injury, including death and property damage.

- 6.3** Commercial Business Automobile Liability Insurance – under ISO Coverage Form No. CA 00 01 10 13, as amended or supplemented from time to time, or an equivalent form acceptable to the NYISO – for coverage of owned and non-owned and hired vehicles, trailers or semi-trailers designed for travel on public roads, with a minimum, combined single limit of One Million Dollars (\$1,000,000) per occurrence for bodily injury, including death, and property damage.
- 6.4** Umbrella/Excess Liability Insurance over and above the Employers’ Liability, Commercial General Liability, and Commercial Business Automobile Liability Insurance coverage, with a minimum combined single limit of Twenty-Five Million Dollars (\$25,000,000) per occurrence/Twenty-Five Million Dollars (\$25,000,000) aggregate.
- 6.5** Builder’s Risk Insurance in a reasonably prudent amount consistent with Good Utility Practice.
- 6.6** The Commercial General Liability Insurance, Commercial Business Automobile Liability Insurance and Umbrella/Excess Liability Insurance policies of ~~the Designated Entity~~NYPA and Transco shall name the NYISO and its respective directors, officers, agents, servants and employees (“NYISO Parties”) as additional insureds. For Commercial General Liability Insurance, ~~the Designated Entity~~NYPA and Transco shall name the NYISO Parties as additional insureds under the following ISO form numbers, as amended or supplemented from time to time, or an equivalent form acceptable to the NYISO: (i) ISO Coverage Form No. CG 20 37 04 13 (“Additional Insured – Owners, Lessees or Contractors – Completed Operations”) and (ii) (A) ISO Coverage Form No. CG 20 10 04 13 (“Additional Insured – Owner, Lessees or Contractors – Scheduled Person or Organization”), or (B) ISO Coverage Form No. CG 20 26 04 13 (“Additional Insured – Designated Person or Organization”). For Commercial Business Automobile Liability Insurance, ~~the Designated Entity~~NYPA and Transco shall name the NYISO Parties as additional insureds under ISO Coverage Form No. CA 20 48 10 13 (“Designated Insured for Covered Autos Liability Coverage”), as amended or supplemented from time to time, or an equivalent form acceptable to the NYISO.
- 6.7** All policies shall contain provisions whereby the insurers waive all rights of subrogation in accordance with the provisions of this Agreement against the NYISO Parties and provide thirty (30) Calendar days advance written notice to the NYISO Parties prior to non-renewal, cancellation or any material change in coverage or condition.
- 6.8** The Commercial General Liability Insurance, Commercial Business Automobile Liability Insurance and Umbrella/Excess Liability Insurance policies shall contain provisions that specify that the policies are primary and shall apply to such extent without consideration for other policies separately carried and shall state that each

SERVICE AGREEMENT NO. 2843

insured is provided coverage as though a separate policy had been issued to each, except ~~the~~each insurer's liability shall not be increased beyond the amount for which ~~the~~that insurer would have been liable had only one insured been covered. ~~The Designated Entity~~NYPA and Transco shall each be responsible for ~~its~~their respective deductibles or retentions.

- 6.9** The Commercial General Liability Insurance, Commercial Business Automobile Liability Insurance and Umbrella/Excess Liability Insurance policies, if written on a Claims First Made Basis in a form acceptable to the NYISO, shall be maintained in full force and effect for two (2) years after termination of this Agreement, which coverage may be in the form of an extended reporting period (ERP) or a separate policy, if agreed by ~~the Designated Entity~~each of NYPA and Transco and the NYISO.
- 6.10** The requirements contained herein as to the types and limits of all insurance to be maintained by ~~the Designated Entity~~NYPA and Transco are not intended to and shall not in any manner, limit or qualify the liabilities and obligations assumed by the ~~Designated Entity~~NY Transco and NYPA under this Agreement.
- 6.11** ~~The Designated Entity~~NYPA and Transco shall each provide certification of all insurance required in this Agreement, executed by each insurer or by an authorized representative of each insurer: (A) within ten (10) days following: (i) execution of this Agreement, or (ii) the NYISO's date of filing this Agreement if it is filed unexecuted with FERC, and (B) as soon as practicable after the end of each fiscal year or at the renewal of the insurance policy and in any event within thirty (30) days thereafter.
- 6.12** Notwithstanding the foregoing, ~~the Designated Entity~~NYPA and Transco each, as applicable, may self-insure to meet the minimum insurance requirements of Articles 6.1 through 6.~~109~~ to the extent it maintains a self-insurance program; *provided that*, ~~the Designated Entity's~~sits respective senior debt is rated at investment grade, or better, by Standard & Poor's and that its self-insurance program meets the minimum insurance requirements of Articles 6.1 through 6.~~109~~. For any period of time that ~~the Designated Entity's~~either of NYPA's or Transco's senior debt is unrated by Standard & Poor's or is rated at less than investment grade by Standard & Poor's, ~~the Designated Entity~~NYPA or Transco, as applicable, shall comply with the insurance requirements applicable to it under Articles 6.1 through 6.~~109~~. In the event that ~~the Designated Entity~~NYPA or Transco, as applicable, is permitted to self-insure pursuant to this Article 6.12, it shall notify the NYISO that it meets the requirements to self-insure and that its self-insurance program meets the minimum insurance requirements in a manner consistent with that specified in Article 6.11.
- 6.13** The Designated Entity and the NYISO agree to report to each other in writing as soon as practical all accidents or occurrences resulting in injuries to any person, including death, and any property damage arising out of this Agreement.
- 6.14** Notwithstanding the minimum insurance coverage types and amounts described in this Article 6, ~~the Designated Entity~~NYPA or Transco: (i) shall also maintain any additional insurance coverage types and amounts required under Applicable Laws and

Regulations, including New York State law, and under Good Utility Practice for the work performed by the Designated Entity and its subcontractors under this Agreement, and (ii) shall satisfy the requirements set forth in Articles 6.6 through 6.13 with regard to the additional insurance coverages, including naming the NYISO Parties as additional insureds under these policies.

ARTICLE 7. BREACH AND DEFAULT

7.1. Breach

A Breach of this Agreement shall occur when: (i) the Designated Entity notifies the NYISO in writing that it will not proceed to develop the Designated Project for reasons other than those set forth in Articles 8.1(i) through (iv); (ii) the Designated Entity fails to meet a Critical Path Milestone, as the milestone may be extended with the agreement of the NYISO under Article 3.3.4 of this Agreement, set forth in the Development Schedule in Appendix C to this Agreement; (iii) the Designated Entity makes a Significant Modification to the Designated Project without the prior written consent of the NYISO; (iv) the Designated Entity fails to pay a monthly invoice within the timeframe set forth in Article 3.6; (v) the Designated Entity misrepresents a material fact of its representations and warranties set forth in Article 12; (vi) a Party assigns this Agreement in a manner inconsistent with the terms of Article 10 of this Agreement; (vii) the Designated Entity fails to file with the Commission any Cost Cap that the Designated Entity submitted to the NYISO as a part of its Public Policy Transmission Project and agreed to in this Agreement or seeks to recover through its transmission rates for the Designated Project or through any other means costs for the Included Capital Costs (as defined in Section 31.4.5.1.8.1 of the ISO OATT) above its Cost Cap, except as permitted for excusing conditions in Section 6.10.6.2 of the ISO OATT and Article 15.3 of this Agreement; (viii) the Designated Entity fails to comply with any other material term or condition of this Agreement; (ix) a custodian, receiver, trustee or liquidator of ~~the Designated Entity~~NYPA or Transco, or of all or substantially all of the assets of ~~the Designated Entity~~NYPA or Transco, is appointed in any proceeding brought by ~~the Designated Entity~~NYPA or Transco; or (x) any such custodian, receiver, trustee, or liquidator is appointed in any proceeding brought against ~~the Designated Entity~~NYPA or Transco that is not discharged within ninety (90) Days after such appointment, or if ~~the Designated Entity~~NYPA or Transco consents to or acquiesces in such appointment. A Breach shall not occur as a result of a Force Majeure event in accordance with Article 15.5. A Breach shall also not occur as a result of a delay caused by another Designated Entity, a Connecting Transmission Owner, or an Affected System Operator.

7.2. Default

Upon a Breach, the non-Breaching Party shall give written notice of the Breach to the Breaching Party describing in reasonable detail the nature of the Breach and, where known and applicable, the steps necessary to cure such Breach, including whether and what such steps must be accomplished to complete the Designated Project by the Required Designated Project In-Service Date. The Breaching Party shall have thirty (30) Calendar Days from receipt of the Breach notice to cure the Breach, or such other period of time as may be agreed upon by the Parties, which agreement the NYISO will not unreasonably withhold, condition, or delay if it determines a longer cure period will not threaten the Designated Entity's ability to complete the

Designated Project by the Required Designated Project In-Service Date or other Designated Entities' ability to complete Designated Public Policy Projects or Designated Network Upgrade Facilities related to the Transmission Project by their required designated project in-service date and the Required Transmission Project In-Service Date; *provided, however*, that if the Breach is the result of a Designated Entity's inability or failure to meet a Critical Path Milestone, the Designated Entity may only cure the Breach if either: (i) it meets the Critical Path Milestone within the cure period and demonstrates to the NYISO's satisfaction that, notwithstanding its failure to timely meet the Critical Path Milestone, the Designated Project will achieve its In-Service Date no later than the Required Designated Project In-Service Date and other Designated Public Policy Projects or Designated Network Upgrade Facilities related to the Transmission Project will achieve their in-service dates before their required designated project in-service dates and the Required Transmission Project In-Service Date, or (ii) the Designated Entity requests in writing within the cure period, and the NYISO consents to, a change to the missed Critical Path Milestone in accordance with Article 3.3.4. If the Breach is cured within such timeframe, the Breach specified in the notice shall cease to exist. If the Breaching Party does not cure its Breach within this timeframe or cannot cure the Breach in a manner that provides for the Designated Project to be completed by the Required Designated Project In-Service Date, the non-Breaching Party shall have the right to declare a Default and terminate this Agreement pursuant to Article 8.1.; *provided, however, that if the Breach is a result of Article 7.1(vi), (vii), or (x) by only one of the parties as between NYPA and Transco and the breaching party as between NYPA and Transco cannot cure its Breach within this timeframe or cannot cure the Breach in a manner that provides for the Designated Project to be completed by the Required Designated Project In-Service Date, the NYISO, as the non-Breaching Party, shall not have the right to declare a Default by the Designated Entity if within in the aforementioned cure timeframe, the breaching party as between NYPA and Transco assigns its rights and obligations under this Agreement to the non-breaching party as between NYPA and Transco in accordance with Article 10 of this Agreement and the non-breaching party as between NYPA and Transco takes steps necessary to otherwise cure such Breach.*

7.3. Remedies

Upon the occurrence of an event of Default, the non-defaulting Party shall be entitled: (i) to commence an action to require the defaulting Party to remedy such Default and specifically perform its duties and obligations hereunder in accordance with the terms and conditions hereof; and (ii) to exercise such other rights and remedies as it may have in equity or at law; *provided, however*, the defaulting Party's liability under this Agreement shall be limited to the extent set forth in Article 9.1. No remedy conferred by any provision of this Agreement is intended to be exclusive of any other remedy and each and every remedy shall be cumulative and shall be in addition to every other remedy given hereunder or now or hereafter existing at law or in equity or by statute or otherwise. The election of any one or more remedies shall not constitute a waiver of the right to pursue other available remedies. This Article 7.3 shall survive the termination, expiration, or cancellation of this Agreement.

ARTICLE 8. TERMINATION

8.1. Termination by the NYISO

The NYISO may terminate this Agreement by providing written notice of termination to the Designated Entity in the event that: (i) the Designated Entity notifies the NYISO that it is unable to or has not received the required approvals or authorizations by Governmental Authorities required to develop, construct, and operate the Designated Project by the Required Designated Project In-Service Date; (ii) the Designated Entity notifies the NYISO that its required approvals or authorizations by Governmental Authorities have been withdrawn by the Governmental Authorities; (iii) the Designated Entity cannot complete the Designated Project by the Required Designated Project In-Service Date for any reason: (A) including the occurrence of a Force Majeure event that will prevent the Designated Entity from completing the Designated Project by the Required Designated Project In-Service Date, but (B) excluding a delay caused by a Connecting Transmission Owner, an Affected System Operator, or other Designated Entity responsible for completing a Designated Public Policy Project or Designated Network Upgrade Facilities related to the Transmission Project; (iv) the NYISO declares a default pursuant to Article 7.2 of this Agreement; or (v) another Designated Entity defaults on the development of a separate Designated Public Policy Project or Designated Network Upgrade Facilities related to the Transmission Project and the ISO determines to address the Public Policy Transmission Need in a future planning cycle pursuant to Section 31.4.12.3.1.2 of Attachment Y of the OATT.

If the NYISO identifies grounds for termination under Articles 8.1(iii) or (iv) or receives notice from the Designated Entity under Articles 8.1(i) or (ii), the NYISO may, prior to providing a written notice of termination, take action in accordance with Sections 31.4.12.3.1.3 and 31.4.12.3.1.4 of Attachment Y of the OATT to address the Public Policy Transmission Need and, notwithstanding the confidentiality provisions in Article 11.2, may disclose information regarding the Transmission Project to Governmental Authorities as needed to implement such action. If the NYISO decides to terminate this Agreement under Article 8.1(i), (ii), (iii), (iv), or (v), it will provide written notice of termination to the Designated Entity, which notice will specify the date of termination. If the Agreement was filed and accepted by FERC pursuant to Section 31.4.12.2 of Attachment Y of the OATT, the NYISO will, following its provision of a notice of termination to the Designated Entity, promptly file with FERC for its acceptance a notice of termination of this Agreement.

In the event of termination under Articles 8.1 (i), (ii), or (v), the Designated Entity may be eligible for cost recovery under the OATT in the manner set forth in Attachment Y and Schedule 10 of the OATT. In the event of termination under Articles 8.1(iii) or (iv), cost recovery may be permitted as determined by FERC. In the event of termination for any reason under this Article 8.1, the Designated Entity shall use commercially reasonable efforts to mitigate the costs, damages, and charges arising as a consequence of termination and any transfer or winding up of the Designated Project.

8.2. Reporting of Inability to Comply with Provisions of Agreement

Notwithstanding the notification requirements in Article 3 and this Article 8 of this Agreement, each Party shall notify the other Party promptly upon the notifying Party becoming

aware of its inability to comply with any provision of this Agreement. The Parties agree to cooperate with each other and provide necessary information regarding such inability to comply, including the date, duration, reason for inability to comply, and corrective actions taken or planned to be taken with respect to such inability to comply.

8.3. Designated Project Transfer Rights Upon Termination

If the NYISO terminates this Agreement pursuant to Article 8.1 (except pursuant to Article 8.1(v)), the NYISO shall have the right, but shall not be required, to request an entity other than the Designated Entity to complete the Designated Public Policy Project. The NYISO may exercise this right by providing the Designated Entity with written notice within sixty (60) days after the date on which this Agreement is terminated. If the NYISO exercises its right under this Article 8.3 and Sections 31.4.12.3.1.3 and 31.4.12.3.1.4 of Attachment Y of the OATT, the Designated Entity shall work cooperatively with the NYISO's designee pursuant to the requirements set forth, as applicable, in Sections 31.4.12.3.1.3 or 31.4.12.3.1.4 of Attachment Y of the OATT to implement the transition, including entering into good faith negotiations with the NYISO's designee to transfer the Designated Public Policy Project to the NYISO's designee. If the NYISO exercises the right to request an entity other than the Designated Entity to complete the Designated Public Policy Project and if there are Designated Network Upgrade Facilities covered by this Agreement, the NYISO may (i) request the Designated Entity to continue with the development of the Designated Network Upgrade Facilities and amend this Agreement to, among other things, revise the Designated Project as described in the Project Description set forth in Appendix A to this Agreement or (ii) execute or amend a Transmission Interconnection Agreement if termination under Articles 8.1(iii) or (iv) is related to the development of Designated Network Upgrade Facilities. All liabilities under this Agreement existing prior to such transfer shall remain with the Designated Entity, unless otherwise agreed upon by the Designated Entity and the NYISO's designee as part of their good faith negotiations regarding the transfer. This Article 8.3 shall survive the termination, expiration, or cancellation of this Agreement.

ARTICLE 9. LIABILITY AND INDEMNIFICATION

9.1. Liability

Notwithstanding any other provision in the NYISO's tariffs and agreements to the contrary, neither Party shall be liable, whether based on contract, indemnification, warranty, equity, tort, strict liability, or otherwise, to the Other Party or any Transmission Owner, NYISO Market Participant, third party or any other person for any damages whatsoever, including, without limitation, direct, incidental, consequential (including, without limitation, attorneys' fees and litigation costs), punitive, special, multiple, exemplary, or indirect damages arising or resulting from any act or omission under this Agreement, except in the event the Party is found liable for gross negligence or intentional misconduct in the performance of its obligations under this Agreement, in which case the Party's liability for damages shall be limited only to direct actual damages. This Article 9.1 shall survive the termination, expiration, or cancellation of this Agreement.

9.2. Indemnity

Notwithstanding any other provision in the NYISO's tariffs and agreements to the contrary, each Party shall at all times indemnify and save harmless, as applicable, the other Party, its directors, officers, employees, trustees, and agents or each of them from any and all damages (including, without limitation, any consequential, incidental, direct, special, indirect, exemplary or punitive damages and economic costs), losses, claims, including claims and actions relating to injury to or death of any person or damage to property, liabilities, judgments, demands, suits, recoveries, costs and expenses, court costs, attorney and expert fees, and all other obligations by or to third parties, arising out of, or in any way resulting from this Agreement, *provided, however*, that the Designated Entity shall not have any indemnification obligation under this Article 9.2 with respect to any loss to the extent the loss results from the gross negligence or intentional misconduct of the NYISO; *provided, further*, that the NYISO shall only have an indemnification obligation under this Article 9.2 with respect to any loss resulting from its gross negligence or intentional misconduct to the same extent as provided in Section 2.11.3(b) of the ISO OATT. This Article 9.2 shall survive the termination, expiration, or cancellation of this Agreement.

ARTICLE 10. ASSIGNMENT

This Agreement may be assigned by a Party only with the prior written consent of the other Party; *provided that*:

- (i) any Change of Control of either NYPA or Transco shall be considered an assignment under this Article 10 and shall require the other Party's prior written consent;
- (ii) an assignment by the Designated Entity shall be contingent upon the Designated Entity or assignee demonstrating to the satisfaction of the NYISO prior to the effective date of the assignment that: (A) the assignee has the technical competence, financial ability, and materials, equipment, and plans to comply with the requirements of this Agreement and to construct and place in service the Designated Project by the Required Designated Project In-Service Date consistent with the assignor's cost estimates for the Designated Project; and (B) the assignee satisfies the requirements for a qualified developer pursuant to Section 31.4.4 of Attachment Y of the OATT; and
- (iii) the Designated Entity shall have the right to assign this Agreement, without the consent of the NYISO, for collateral security purposes to aid in providing financing for the Designated Project and shall promptly notify the NYISO of any such assignment; *provided, however*, that such assignment shall be subject to the following: (i) prior to or upon the exercise of the secured creditor's, trustee's, or mortgagee's assignment rights pursuant to said arrangement, the secured creditor, the trustee, or the mortgagee will notify the NYISO of the date and particulars of any such exercise of assignment right(s), and (ii) the secured creditor, trustee, or mortgagee must demonstrate to the satisfaction of the NYISO that any entity that

it proposes to complete the Designated Project meets the requirements for the assignee of a Designated Entity described in Article 10(ii).

NYPA and Transco may assign this Agreement to the other party only with the prior written consent of the other party and the NYISO, provided that the assignee must meet the requirements set forth in Article 10(ii).

For all assignments by any Party, the assignee must assume in a writing, to be provided to the other Party, all rights, duties, and obligations of the assignor arising under this Agreement, including the insurance requirements in Article 6 of this Agreement. Any assignment under this Agreement shall not relieve a Party of its obligations, nor shall a Party's obligations be enlarged, in whole or in part, by reasons thereof, absent the written consent of the other ~~Party~~Parties. Where required, consent to assignment will not be unreasonably withheld, conditioned, or delayed. Any attempted assignment that violates this Article 10 is void and ineffective, is a Breach of this Agreement under Article 7.1 and may result in the termination of this Agreement under Articles 8.1 and 7.2.

ARTICLE 11. INFORMATION EXCHANGE AND CONFIDENTIALITY

11.1. Information Access

Subject to Applicable Laws and Regulations, each Party shall make available to the other Party information necessary to carry out obligations and responsibilities under this Agreement and Attachment Y of the OATT. The Parties shall not use such information for purposes other than to carry out their obligations or enforce their rights under this Agreement or Attachment Y of the OATT.

11.2. Confidentiality

- 11.2.1. Confidential Information shall mean: (i) all detailed price information and vendor contracts; (ii) any confidential and/or proprietary information provided by one Party to the other Party that is clearly marked or otherwise designated "Confidential Information"; and (iii) information designated as Confidential Information by the NYISO Code of Conduct contained in Attachment F of the OATT; *provided, however*, that Confidential Information does not include information: (i) in the public domain or that has been previously publicly disclosed; (ii) required by an order of a Governmental Authority to be publicly submitted or divulged (after notice to the other Party); or (iii) necessary to be divulged in an action to enforce this Agreement.
- 11.2.2. The NYISO shall treat any Confidential Information it receives in accordance with the requirements of the NYISO Code of Conduct contained in Attachment F of the OATT. If the Designated Entity receives Confidential Information, it shall hold such information in confidence, employing at least the same standard of care to protect the Confidential Information obtained from the NYISO as it employs to protect its own Confidential Information. Each Party shall not disclose the other Party's Confidential Information to any third party or to the public without the prior written authorization of the Party providing the information, except: (i) to the extent required for the Parties to perform their obligations under this Agreement, the ISO Tariffs, ISO Related

Agreements, or ISO Procedures, or (ii) to fulfill legal or regulatory requirements, provided that if the Party must submit the information to a Governmental Authority in response to a request by the Governmental Authority on a confidential basis, the Party required to disclose the information shall request under applicable rules and regulations that the information be treated as confidential and non-public by the Governmental Authority. If NYPA receives a request for disclosure of Confidential Information pursuant to Section 87(2)(d) of the New York Public Officers Law, NYPA shall provide prompt notice to the other parties to afford an opportunity to address the confidential nature of the information provided and will undertake reasonable efforts to protect the information from disclosure to the extent such information is exempt from disclosure under Section 87(2)(d) of the New York Public Officers Law.

ARTICLE 12. REPRESENTATIONS, WARRANTIES AND COVENANTS

12.1. General

The Designated Entity makes NYPA and Transco each make the following representations, warranties, and covenants, which are effective as to ~~the Designated Entity~~ NYPA and Transco, as applicable, during the full time this Agreement is effective. For purposes of this Article 12, references to “Designated Entity” mean NYPA or Transco individually, as applicable, rather than collectively.

12.2. Good Standing

The Designated Entity is duly organized, validly existing and in good standing under the laws of the state in which it is organized, formed, or incorporated, as applicable. The Designated Entity is qualified to do business in the state or states in which the Designated Project is located. The Designated Entity has the corporate power and authority to own its properties, to carry on its business as now being conducted and to enter into this Agreement and carry out the transactions contemplated hereby and to perform and carry out covenants and obligations on its part under and pursuant to this Agreement.

12.3. Authority

The Designated Entity has the right, power, and authority to enter into this Agreement, to become a Party hereto, and to perform its obligations hereunder. This Agreement is a legal, valid, and binding obligation of the Designated Entity, enforceable against the Designated Entity in accordance with its terms, except as the enforceability thereof may be limited by applicable bankruptcy, insolvency, reorganization, or other similar laws affecting creditors’ rights generally and by general equitable principles (regardless of whether enforceability is sought in a proceeding in equity or at law).

12.4. No Conflict

The execution, delivery and performance of this Agreement does not violate or conflict with the organizational or formation documents, or bylaws or operating agreement, of the

SERVICE AGREEMENT NO. 2843

Designated Entity, or any judgment, license, permit, order, material agreement or instrument applicable to or binding upon the Designated Entity or any of its assets.

12.5. Consent and Approval

The Designated Entity has sought or obtained, or, in accordance with this Agreement will seek or obtain, such consent, approval, authorization, order, or acceptance by any Governmental Authority in connection with the execution, delivery and performance of this Agreement, and it will provide to any Governmental Authority notice of any actions under this Agreement that are required by Applicable Laws and Regulations.

12.6. Compliance with All Applicable Laws and Regulations

The Designated Entity will comply with all Applicable Laws and Regulations, including all approvals, authorizations, orders, and permits issued by any Governmental Authority; all Applicable Reliability Requirements, and all applicable Transmission Owner Technical Standards in the performance of its obligations under this Agreement.

ARTICLE 13. DISPUTE RESOLUTION

If a dispute arises under this Agreement between the Designated Entity and the NYISO, the Parties shall use the dispute resolution process described in Article 11 of the NYISO's Services Tariff, as such process may be amended from time to time. Notwithstanding the process described in Article 11 of the NYISO's Services Tariff, the NYISO may terminate this Agreement in accordance with Article 8 of this Agreement. Any dispute that arises between NYPA and Transco directly related to one or the other's performance of this Agreement is not covered by this Article 13 and shall be resolved outside of this Agreement by NYPA and Transco without the NYISO's required involvement.

ARTICLE 14. SURVIVAL

The rights and obligations of the Parties in this Agreement shall survive the termination, expiration, or cancellation of this Agreement to the extent necessary to provide for the determination and enforcement of said obligations arising from acts or events that occurred while this Agreement was in effect. The remedies and rights and obligation upon termination provisions in Articles 7.3 and 8.3 of this Agreement, the liability and indemnity provisions in Article 9, the cost recovery provisions in Article 15.3 and Appendix D, and the billing and payment provisions in Article 3.6 of this Agreement shall survive termination, expiration, or cancellation of this Agreement.

ARTICLE 15. MISCELLANEOUS

15.1. Notices

~~Any notice or request made to or by any Party regarding this Agreement shall be made to the Parties, as indicated below:~~

~~—— NYISO:~~

SERVICE AGREEMENT NO. 2843

[Insert contact information.]

Designated Entity:

[Insert contact information.] Designated Entity shall designate a project manager, authorized to receive and provide all notices that are required or that may be sent under the terms of this Agreement. Notice by the NYISO to the designated project manager constitutes notice to both NYPA and Transco, and notice from the designated project manager to the NYISO constitutes notice from both NYPA and Transco. The NYISO shall also provide a courtesy copy of all notices that are sent to the designated project manager to as indicated in the contact listed below; however, only notice provided by the NYISO to the designated project manager shall constitute notice that is required or that may be sent under the terms of this Agreement. Any notice or request made to or by any Party regarding this Agreement shall be made to the Parties, as indicated below. _____

The New York Independent System Operator, Inc.
Attn: Zachary G. Smith
Vice President, System and Resource Planning
10 Krey Boulevard
Rensselaer, NY 12144
Phone: (518) 356-6000
Fax: (518) 356-6118

Designated Entity Designated Project Manager

New York Transco LLC
Attn: Stephen Cole-Hatchard, Jr.
Director of Capital Projects
300 Westage Business Center Drive, Suite 180
Fishkill, New York 12524
Phone: (518) 949-1129
Email: Stephen.Colehatchard@Nytransco.com

Copy to:

New York Power Authority
Attn: Ana Stachowiak, P.E.
Sr. Program Director, Projects Development
123 Main Street, 14th Floor
White Plains, NY 10601
Phone: (914) 681-6250
Email: ana.stachowiak@nypa.gov

Designated Entity Billing and Payment Contact

New York Transco LLC
Attn: Stephen Cole-Hatchard, Jr.
Director of Capital Projects
300 Westage Business Center Drive, Suite 180

Fishkill, New York 12524

Phone: (518) 949-1129

Email: Stephen.Colehatchard@Nytransco.com

15.2. Entire Agreement

Except as described below in this Section 15.2, this Agreement, including all Appendices attached hereto, constitutes the entire agreement between the Parties with reference to the subject matter hereof, and supersedes all prior and contemporaneous understandings of agreements, oral or written, between the Parties with respect to the subject matter of this Agreement. There are no other agreements, representations, warranties, or covenants that constitute any part of the consideration for, or any condition to, either Party's compliance with its obligation under this Agreement.

Notwithstanding the foregoing, this Agreement is in addition to, and does not supersede or limit the Designated Entity's and NYISO's rights and responsibilities, under any interconnection agreement(s) entered into by and among the NYISO, Designated Entity, and Connecting Transmission Owner(s) for the Designated Project to interconnect to the New York State Transmission System, as such interconnection agreements may be amended, supplemented, or modified from time to time.

15.3. Cost Recovery

The Designated Entity may recover the costs of the Designated Project in accordance with the cost recovery requirements in the ISO Tariffs. If the Designated Entity submitted a Cost Cap for the Included Capital Costs (as defined in Section 31.4.5.1.8.1 of the ISO OATT) of the Designated Project pursuant to Section 31.4.5.1 of the ISO OATT, the Designated Entity's Cost Cap for the Included Capital Costs shall be detailed in Appendix D of this Agreement, which description shall include the Cost Cap in the Designated Entity's project proposal. Designated Entity agrees to file this Cost Cap for Included Capital Costs with the Commission in accordance with the requirements in Rate Schedule 10 of the ISO OATT-: provided that if NYPA and Transco submit separate transmission rate filings for the recovery of their costs in connection with the Designated Project, NYPA and Transco must establish in those filings that they cannot collectively recover through their separate transmission rate recovery an amount higher than is permitted for the Designated Entity to recover pursuant to this Article 15.3. If the Cost Cap is a soft Cost Cap, Designated Entity agrees to implement the Cost Cap in accordance with Section 6.10.6.3 of Rate Schedule 10. The Designated Entity further agrees in accordance with Rate Schedule 10 of the OATT that it shall not seek to recover through its transmission rates for the Designated Project or through any other means costs for the Included Capital Cost above its agreed-upon Cost Cap; *provided, however*, the Designated Entity may recover costs above its agreed-upon Cost Cap resulting from one of the following excusing conditions, but only to the extent the costs arise from the excusing condition:

- A. Designated Project changes, delays, or additional costs that are due to the actions or omissions of the ISO, Connecting Transmission Owner(s), Interconnecting Transmission Owner(s), Affected Transmission Owner(s), or other Designated Entity(ies) responsible for completing other parts of the Transmission Project;

- B. A Force Majeure event as defined in this Agreement and subject to the Force Majeure requirements in Section 15.5 of this Agreement;
- C. Changes in laws or regulations, including but not limited to applicable taxes;
- D. Material modifications to scope or routing arising from siting processes under Public Service Law Article VII or applicable local laws as determined by the New York State Public Service Commission or local governments respectively; and
- E. Actions or inactions of regulatory or governmental entities, and court orders.

The provisions of this Section 15.3 and the Designated Entity's Cost Cap for the Included Capital Costs detailed in Appendix D shall not be subject to change through application to the Federal Energy Regulatory Commission pursuant to the provisions of Section 205 of the Federal Power Act absent the agreement of all Parties to the Agreement. In any proceeding conducted pursuant to Section 206 of the Federal Power Act, the standard of review for any change to this Section 15.3 and the Designated Entity's Cost Cap for the Included Capital Costs detailed in Appendix D shall be the "public interest" application of the just and reasonable standard set forth in *United Gas Pipe Line Co. v. Mobile Gas Serv. Corp.*, 350 U.S. 332 (1956), and *Fed. Power Comm'n v. Sierra Pacific Power Co.*, 350 U.S. 348 (1956), as clarified in *Morgan Stanley Capital Grp., Inc. v. Pub. Util. Dist. No. 1 of Snohomish Cnty., Wash.*, 554 U.S. 527 (2008), and refined in *NRG Power Mktg. v. Maine Pub. Utils. Comm'n*, 558 U.S. 165 (2010).

15.4. Binding Effect

This Agreement, and the rights and obligations hereof, shall be binding upon and shall inure to the benefit of the successors and permitted assigns of the Parties hereto.

15.5. Force Majeure

A Party that is unable to carry out an obligation imposed on it by this Agreement due to Force Majeure shall notify the other Party in writing as soon as reasonably practicable after the occurrence of the Force Majeure event and no later than the timeframe set forth in Article 3.3.3(i) if the Force Majeure event will result in a potential delay for the Designated Entity to meet a Critical Path Milestone. If the notifying Party is the Designated Entity, it shall indicate in its notice whether the occurrence of a Force Majeure event has the potential to delay its meeting one or more Critical Path Milestones and/or completing the Designated Project in time for other Designated Public Policy Projects or Designated Network Upgrade Facilities related to the Transmission Project to go into service by their required designated project in-service date(s) and the Required Transmission Project In-Service Date. If the Force Majeure will delay the Designated Entity's ability to meet one or more Critical Path Milestones, the Designated Entity shall request with its notice a change to the impacted milestones in accordance with the requirements in Section 3.3.4 and must satisfy the requirements in Section 3.3.4 to change any Critical Path Milestones. A Party shall not be responsible for any non-performance or considered in Breach or Default under this Agreement, for any failure to perform any obligation under this Agreement to the extent that such failure is due to Force Majeure and will not delay the Designated Entity's ability to complete the Designated Project by the Required Designated Project In-Service Date. A Party shall be excused from whatever performance is affected only

for the duration of the Force Majeure and while the Party exercises reasonable efforts to alleviate such situation. As soon as the nonperforming Party is able to resume performance of its obligations excused because of the occurrence of Force Majeure, such Party shall resume performance and give prompt notice thereof to the other Party. In the event that the Designated Entity will not be able to complete the Designated Project by the Required Designated Project In-Service Date because of the occurrence of Force Majeure, the NYISO may terminate this Agreement in accordance with Section 8.1 of this Agreement.

15.6. Disclaimer

Except as provided in this Agreement, the Parties make no other representations, warranties, covenants, guarantees, agreements or promises regarding the subject matter of this Agreement.

15.7. No NYISO Liability for Review or Approval of Designated Entity Materials

No review or approval by the NYISO or its subcontractor(s) of any agreement, document, instrument, drawing, specifications, or design proposed by the Developer that submitted the Transmission Project under Attachment Y of the ISO OATT or by the Designated Entity nor any inspection carried out by the NYISO or its subcontractor(s) pursuant to this Agreement shall relieve the Designated Entity from any liability for any negligence in its preparation of such agreement, document, instrument, drawing, specification, or design, or its carrying out of such works; or for its failure to comply with the Applicable Laws and Regulations, Applicable Reliability Requirements, and Transmission Owner Technical Standards with respect thereto, nor shall the NYISO be liable to the Designated Entity or any other person by reason of its or its subcontractor's review or approval of an agreement, document, instrument, drawing, specification, or design or such inspection.

15.8. Amendment

The Parties may by mutual agreement amend this Agreement, including the Appendices to this Agreement, by a written instrument duly executed by both of the Parties. If the Agreement was filed and accepted by FERC pursuant to Section 31.4.12.2 of Attachment Y of the OATT, the NYISO shall promptly file the amended Agreement for acceptance with FERC.

15.9. No Third Party Beneficiaries

With the exception of the indemnification rights of the NYISO's directors, officers, employees, trustees, and agents under Article 9.2, this Agreement is not intended to and does not create rights, remedies, or benefits of any character whatsoever in favor of any persons, corporations, associations, or entities other than the Parties, and the obligations herein assumed are solely for the use and benefit of the Parties, their successors in interest and their permitted assigns.

15.10. Waiver

The failure of a Party to this Agreement to insist, on any occasion, upon strict performance of any provision of this Agreement will not be considered a waiver of any

obligation, right, or duty of, or imposed upon, such Party. Any waiver at any time by either Party of its rights with respect to this Agreement shall not be deemed a continuing waiver or a waiver with respect to any other failure to comply with any other obligation, right, or duty of this Agreement. Any waiver of this Agreement shall, if requested, be provided in writing.

15.11. Rules of Interpretation

This Agreement, unless a clear contrary intention appears, shall be construed and interpreted as follows: (1) the singular number includes the plural number and vice versa; except with respect to the definition of “Designated Entity;” (2) reference to any person includes such person’s successors and assigns but, in the case of a Party, only if such successors and assigns are permitted by this Agreement, and reference to a person in a particular capacity excludes such person in any other capacity or individually; (3) reference to any agreement (including this Agreement), document, instrument or tariff means such agreement, document, instrument, or tariff as amended or modified and in effect from time to time in accordance with the terms thereof and, if applicable, the terms hereof; (4) reference to any Applicable Laws and Regulations means such Applicable Laws and Regulations as amended, modified, codified, or reenacted, in whole or in part, and in effect from time to time, including, if applicable, rules and regulations promulgated thereunder; (5) unless expressly stated otherwise, reference to any Article, Section or Appendix means such Article of this Agreement, such Appendix to this Agreement, or such Section of this Agreement, as the case may be; (6) “hereunder”, “hereof”, “herein”, “hereto” and words of similar import shall be deemed references to this Agreement as a whole and not to any particular Article or other provision hereof or thereof; (7) “including” (and with correlative meaning “include”) means including without limiting the generality of any description preceding such term; and (8) relative to the determination of any period of time, “from” means “from and including”, “to” means “to but excluding” and “through” means “through and including”.

15.12. Severability

Each provision of this Agreement shall be considered severable and if, for any reason, any provision is determined by a court or regulatory authority of competent jurisdiction to be invalid, void, or unenforceable, the remaining provisions of this Agreement shall continue in full force and effect and shall in no way be affected, impaired, or invalidated, and such invalid, void, or unenforceable provision should be replaced with valid and enforceable provision or provisions that otherwise give effect to the original intent of the invalid, void, or unenforceable provision.

15.13. Multiple Counterparts

This Agreement may be executed in two or more counterparts, each of which is deemed an original, but all constitute one and the same instrument.

15.14. No Partnership

This Agreement shall not be interpreted or construed to create an association, joint venture, agency relationship, or partnership between or among the Parties NYISO and the Designated Entity (either collectively or individually with NYPA and Transco) or to impose any partnership obligation or partnership liability ~~upon any Party~~ between or among the NYISO,

NYPA, or Transco. No Party shall have any right, power, or authority to enter into any agreement or undertaking for, or act on behalf of, or to act as or be an agent or representative of, or otherwise bind, any other Party.

15.15. Headings

The descriptive headings of the various Articles and Sections of this Agreement have been inserted for convenience of reference only and are of no significance in the interpretation or construction of this Agreement.

15.16. Governing Law

This Agreement shall be governed, as applicable, by: (i) the Federal Power Act, and (ii) the substantive law of the State of New York, without regard to any conflicts of laws provisions thereof (except to the extent applicable, Sections 5-1401 and 5-1402 of the New York General Obligations Law).

15.17. Jurisdiction and Venue

Any legal action or judicial proceeding regarding a dispute arising out of or relating to this Agreement or any performance by either Party pursuant thereto that: (i) is within the primary or exclusive jurisdiction of FERC shall be brought in the first instance at FERC, or (ii) is not within the primary or exclusive jurisdiction of FERC shall be brought in, and fully and finally resolved in, either, as applicable, the courts of the State of New York situated in Albany County, New York or the United States District Court of the Northern District of New York situated in Albany, New York.

SERVICE AGREEMENT NO. 2843

IN WITNESS WHEREFORE, the Parties have executed this Agreement in duplicate originals, each of which shall constitute an original Agreement between the Parties.

NYISO

By: _____

Title: _____

Date: _____

~~{Insert name of Designated Entity}~~

By: _____

Title: _____

The New York Independent System Operator, Inc.

By: _____

Title: _____

Date: _____

SERVICE AGREEMENT NO. 2843

New York Power Authority

By: _____

Title: _____

Date: _____

New York Transco LLC

By: _____

Title: _____

Date: _____

**Appendix A—
Project Description**

1. Transmission Project Overview

The transmission project is the T051 Propel Alternate Solution 5 (“Transmission Project”) that was submitted~~Appendix B~~ Scope of Work

Appendix C – Development Schedule

~~[To be prepared by Designated Entity consistent with the project information submission pursuant to Attachment C of the Public Policy Transmission Planning Process Manual, and subject to acceptance by the NYISO, as required by Article 3.3 of this Agreement.]~~

~~_____ by the NYPA and Transco, collectively “Propel NY,” and evaluated in the NYISO’s Public Policy Transmission Planning Process and selected by the NYISO Board of Directors on June 13, 2023 as the more efficient or cost-effective transmission solution to the Long Island Public Policy Transmission Need identified by the New York State Public Service Commission on March 19, 2021 in its order in Case No. 20-E-0497. The Transmission Project will be located in Dunwoodie (Zone I), New York City (Zone J), and Long Island (Zone K) in the State of New York and is principally comprised of three new PAR-controlled 345 kV Long Island ties lines (two between Shore Road and Sprain Brook and one between East Garden City and Tremont), a Shore Road – Ruland Road – East Garden City 345 kV backbone, and other transmission facilities in Long Island.~~

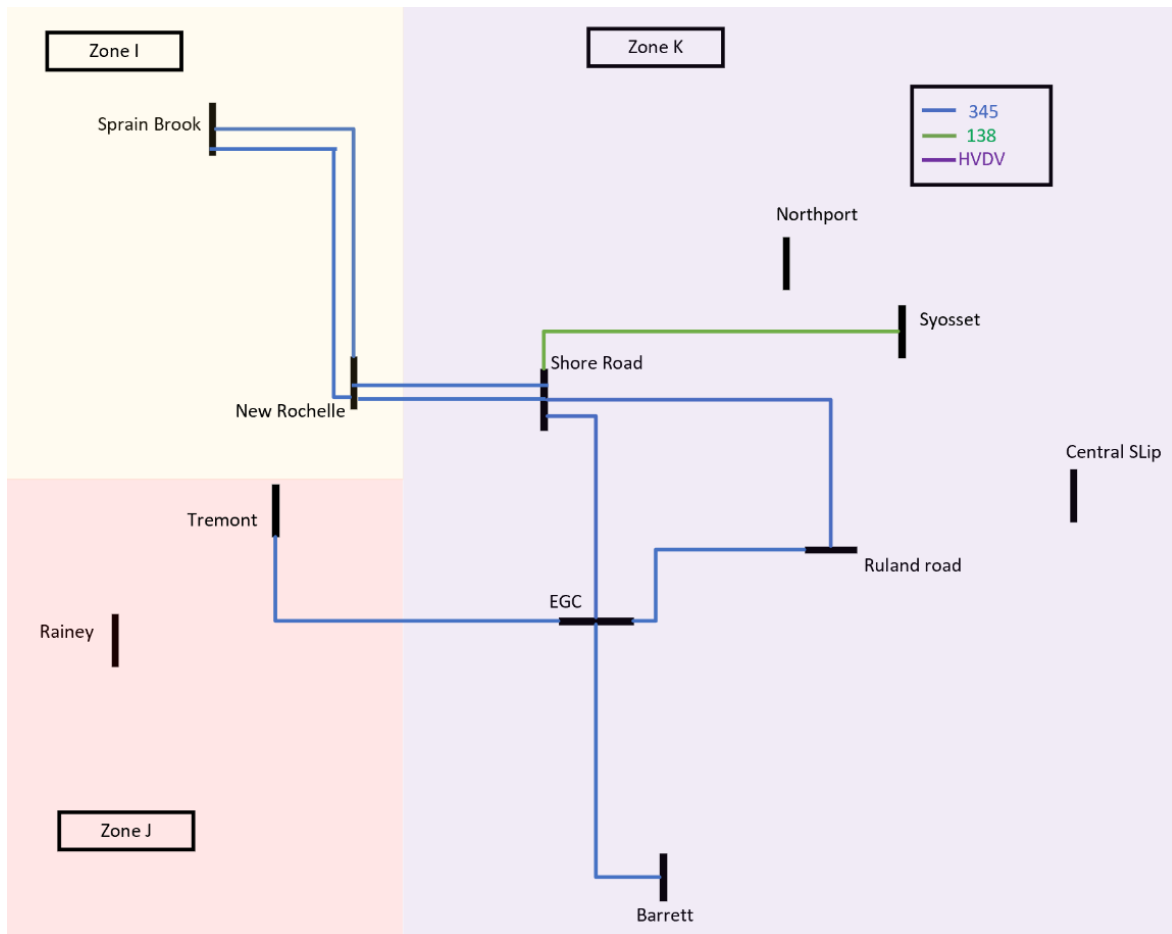

2. Components of the Transmission Project

The Transmission Project consists of the following components:

- Build a proposed Barrett 345 kV substation with two 345/138 kV transformers in series with 138 kV PARs controlling flow towards the 138 kV substation, which is proposed to connect an offshore wind facility in the NYISO's interconnection queue, near the existing Barrett substation and one 100 MVAR shunt reactor,
- Build a proposed New Shore Road 345 kV substation with a 345/138 kV transformer in series with a 138 kV PAR to connect to the existing Shore Road 345/138 kV substation, two 345 kV PARs controlling flow between the New Rochelle 345 kV station and New Shore Road 345 kV substation, two 150 MVAR shunt reactors, and one 100 MVAR shunt reactor,
- Build a proposed Ruland Road substation consisting of a 345 kV six-breaker-ring configuration with three 345/138 kV transformers connecting to a 138 kV six-breaker-ring substation, a 345 kV PAR controlling flow between the Ruland Rd 345 kV station and East Garden City 345 kV substation, and two 150 MVAR shunt reactors,
- Build a proposed New Rochelle 345 kV transition substation consisting of six 345 kV air insulated disconnect switches and rigid buses,
- Build one proposed underground Barrett – East Garden City 345 kV alternating current (“AC”) line,
- Build a 345 kV PAR-controlled tie line from the East Garden City 345 kV substation interconnected to the existing Tremont 345 kV substation,
- Build a proposed underground East Garden City – New Shore Road 345 kV AC line,
- Build a proposed underground Ruland Road – New Shore Road 345 kV AC line,
- Build two proposed underground/submarine New Shore Road – New Rochelle – Sprain Brook 345 kV AC lines,
- Build a 138 kV line from the existing Syosset 138 kV substation to the existing Shore Road 345/138 kV substation,
- Convert and reconfigure the existing Ruland Road – New Bridge 138 kV circuit 3 and New Bridge – East Garden City 138 kV circuit 4 to a proposed Ruland Road – East Garden City 345 kV PAR-controlled line, bypassing the existing New Bridge 138 kV substation,

SERVICE AGREEMENT NO. 2843

- Install Plug and Switch System (“PASS”) breakers (i.e., two breakers in series with integral switches) in place of breakers 1E and 6E at the existing Rainey 345 kV substation.
- Modify the existing East Garden City 345 kV substation to a breaker-and-a-half configuration with a PAR-controlled connection of the existing Y49 345 kV line (i.e., the two existing Y49 345/138 kV transformers will be used to connect the East Garden City 345 kV substation to the existing East Garden City 138 kV substation).
- Install series reactors on the following five existing 138 kV lines: Ruland Road – New Bridge (Lines 561, 562), East Garden City – New Bridge (Lines 462, 463), and East Garden City – Valley Stream (Line 262).
- Uprate the 2.5-mile segment of each of the existing Syosset – Greenlawn 138 kV line (Line 676) and the Syosset – Oakwood 138 kV (Line 675) line.
- Install a second PAR at the existing 138 kV Northport substation.
- Install a PASS breaker in place of breaker CB-1460 at the existing New Bridge 138 kV substation.
- Install a circuit breaker between the Holbrook 138/69 kV transformers 2 & 2A and the Holbrook – Ruland Road 138 kV line (Line 882) at the existing Holbrook 138 kV substation.
- Upgrade the Central Islip – Hauppauge 138 kV line (Line 889), and
- Modify relay systems to eliminate P5 contingencies at multiple substations, including Valley Stream 138 kV substation, Lake Success 138 kV substation, East Garden City 138 kV substation, and Barrett 138 kV substation.

3. Components of the Designated Project

- Build a proposed Barrett 345 kV substation with two 345/138 kV transformers in series with 138 kV PARs controlling flow towards the 138 kV substation, which is proposed to connect an offshore wind facility in the NYISO’s interconnection queue, near the existing Barrett substation and one 100 MVAR shunt reactor.
- Build a proposed New Shore Road 345 kV substation with a 345/138 kV transformer in series with a 138 kV PAR to connect to the existing Shore Road 345/138 kV substation, two 345 kV PARs controlling flow between the New Rochelle 345 kV station and New Shore Road 345 kV substation, two 150 MVAR shunt reactors, and one 100 MVAR shunt reactor.
- Build a proposed Ruland Road substation consisting of a 345 kV six-breaker-ring configuration with three 345/138 kV transformers connecting to a 138 kV six-

SERVICE AGREEMENT NO. 2843

breaker-ring substation, a 345 kV PAR controlling flow between the Ruland Rd 345 kV station and East Garden City 345 kV substation, and two 150 MVAR shunt reactors,

- Build a proposed New Rochelle 345 kV transition substation consisting of six 345 kV air insulated disconnect switches and rigid buses,
- Build one proposed underground Barrett – East Garden City 345 kV alternating current AC line,
- Build a 345 kV PAR-controlled tie line from the East Garden City 345 kV substation interconnected to the existing Tremont 345 kV substation,
- Build a proposed underground East Garden City – New Shore Road 345 kV AC line,
- Build a proposed underground Ruland Road – New Shore Road 345 kV AC line,
- Build two proposed underground/submarine New Shore Road – New Rochelle – Sprain Brook 345 kV AC lines, and
- Build a 138 kV line from the existing Syosset 138 kV substation to the existing Shore Road 345/138 kV substation.

4. Interconnection Facilities

Designated Entity submitted an Interconnection Request for the Transmission Project to be studied in the NYISO’s Transmission Interconnection Procedures under Attachment P to the NYISO’s Open Access Transmission Tariff (“ISO OATT”). The NYISO assigned the Transmission Project Queue No. 1289. This Agreement was executed prior to the completion of the NYISO’s evaluation of the impact of the Designated Project on the New York State Transmission System and execution of all necessary Transmission Project Interconnection Agreements. As a result, the interconnection and operation of the Designated Project are expected to require the construction of Network Upgrade Facilities, as applicable, which will be identified through the Transmission Interconnection Procedures. The identified facilities and associated responsibilities in designing, engineering, procuring, installing, constructing, testing, and commissioning will be addressed in the Transmission Project Interconnection Agreements and/or associated engineering, procurement, and construction agreements among the Designated Entity, the Connecting Transmission Owner(s) and/or the Affected System Operator(s), and the NYISO. In the event that the identification of those facilities materially affects the facilities to be constructed under this Agreement, the Parties will amend this Agreement, as necessary, pursuant to the terms of this Agreement.

Appendix B
Scope of Work

1. Designated Project:

The Designated Entity shall design, engineer, procure, install, construct, test, and commission the Designated Project as described in Appendix A of this Agreement and pursuant to this Appendix B. Any required Network Upgrade Facilities shall be identified and finalized in the Transmission Interconnection Procedures and addressed in any Transmission Project Interconnection Agreement and/or associated engineering, procurement, and construction agreements, as applicable, among the Designated Entity, the Connecting Transmission Owner(s), and/or Affected System Operator(s), as applicable. Based on a preliminary design of the Transmission Project, the components of the Designated Project will consist of the following major electrical and physical equipment:

a. Barrett 345 kV Substation

Furnish and install one (1) 345 kV, 63 kA, air-insulated, outdoor-rated 345 kV, 3000 A, substation with the following major equipment:

- Three (3) 345 kV, 3000 A, 63 kA, gas-insulated switchgear (“GIS”) Plug and Switch System (“PASS”) circuit breakers
- Two (2) 345/138 kV/13.8 kV, Y-Y- TrDelta connected, transformers with 13.8 kV delta tertiary winding with a summer rating of at least 462 MVA Normal/562 MVA LTE/675 MVA STE and winter rating of at least 540 MVA Normal /585 MVA LTE/675 MVA STE
- Two (2) 138 kV, PAR transformers with at least +/- 25 degree angle shifting capability rated at least 462 MVA Normal/562 MVA LTE/675 MVA STE and a winter rating of at least 540 MVA Normal /585 MVA LTE/675 MVA STE
- One (1) 345 kV, oil-filled shunt reactor rated 100 MVAR
- One (1) 345 kV, 3000 A, 100 kA, double break, manually operated, disconnect switches
- Two (2) 138 kV rated, 3000 A, 100 kA, 650 kV BIL, double break, manually operated, disconnect switches
- Two sets of 138 kV, 3000 A, 63 kA revenue metering grade combination units
- One set of three (3) 345 kV 1550 BIL kV coupling capacitors voltage transformers
- One (1) 45 ft. by 25 ft. control enclosure
- Associated 345 kV and 138 kV conductor, hardware, and fittings
- Associated trench and conduit system
- Associated foundations
- Associated steel support structures

SERVICE AGREEMENT NO. 2843

- Stormwater fixtures
- Required earthwork, grading and finish stone
- New perimeter fence
- New station ground grid
- Required station lightning masts, lighting and security system
- Relays, panels, controls, comm equipment, as required
- Associated material and hardware, as required

b. Ruland Road 345 kV-138 kV Substation

Furnish and install one (1) 345 kV, 63 kV, 3000 A, six (6) breaker position ring bus air-insulated substation (“AIS”) arrangement with the following major equipment:

- Eight (8) 345 kV, 3000 A, 63 kA, PASS circuit breakers
- Three (3) 345/138 kV/13.8 kV, Y-Y-Delta connected with a summer rating of at least 462 MVA Normal/562 MVA LTE/675 MVA STE and a winter rating of at least 540 MVA Normal/562 MVA LTE/675 MVA STE
- One (1) 345 kV, PAR transformer with +/- 40 degree angle shifting capability with a summer rating of at least 607 MVA Normal/810 MVA LTE/985 MVA STE and a winter rating of at least 648 MVA Normal/970 MVA LTE/1068 MVA STE
- Two (2) 345 kV, oil-filled shunt reactors rated 150 MVAR
- Five (5) 345 kV, 3000 A, 100 kA, double break, manually operated, disconnect switches
- Six sets of three (3) 345 kV 1550 BIL kV coupling capacitors voltage transformers
- Associated 345 kV conductor, hardware, and fittings
- Associated trench and conduit system
- Associated foundations
- Associated steel support structures
- Stormwater fixtures.
- Required earthwork, grading and finish stone
- New perimeter fence
- New station ground grid
- Required station lightning masts, lighting and security system
- Relays, panels, controls, comm equipment, as required
- Associated material and hardware, as required

SERVICE AGREEMENT NO. 2843

Furnish and install one (1) 138 kV, 63 kA, 3000 A, six (6) breaker position ring AIS bus arrangement with the following major equipment:

- Six (6) 138 kV, 3000 A, 63 kA, PASS circuit breakers
- Five (5) 138 kV rated, 3000 A, 100 kA, double break, manually operated, disconnect switches
- Six sets of three (3) 345 kV 1550 BIL kV coupling capacitors voltage transformers
- One (1) 65 ft. by 25 ft. control enclosure
- Associated 138 kV conductor, hardware, and fittings
- Associated trench and conduit system
- Associated foundations
- Associated steel support structures
- Stormwater fixtures
- Required earthwork, grading and finish stone
- New perimeter fence
- New station ground grid
- Required station lightning masts, lighting and security system
- Relays, panels, controls, comm equipment, as required
- Associated material and hardware, as required

c. Shore Road 345 kV-138 kV Substation

Furnish and install one (1) 345 kV, 63 kA outdoor rated 345 kV, 3000 A, 63 kA, five breaker position ring bus arrangement that is expandable to six (6) breaker position ring outdoor GIS bus arrangement with the following major equipment:

- One (1) 345 kV /138 kV/13.8 kV, Y-Y-Delta connected autotransformer with a summer rating of at least 462MVA Normal/562 MVA LTE/675 MVA STE and winter rating of at least 540 MVA Normal /562 MVA LTE /675 MVA STE
- Two (2) 345 kV, PAR transformer with +/- 40 degree angle shifting capability with a summer rating of at least 709 MVA Normal/957 MVA LTE/1052 MVA STE and winter rating of at least 897 MVA Normal /1130 MVA LTE/1271 MVA STE
- Two (2) 345 kV, oil-filled shunt reactors rated 150 MVAr
- One (1) 345 kV, oil-filled shunt reactor rated at least 106 MVAr
- Eight (8) 345 kV, 63 kA outdoor rated 345 kV, 3000 A, 63 kA GIS breakers
- Five sets of three (3) 345 kV GIS potential transformers

- Gas insulated bus (“GIB”)
- Eight (8) local control cabinets (“LCC”)
- GIS and GIB steel support structures
- Associated 138 kV conductor, hardware, and fittings
- Associated trench and conduit system
- Associated foundations
- Associated steel support structures
- Stormwater fixtures
- Required earthwork, grading and finish stone
- New perimeter fence
- New station ground grid
- Required station lightning masts, lighting and security system
- Relays, panels, controls, comm equipment, as required
- Associated material and hardware, as required

d. 345 kV New Rochelle Station

Build a proposed New Rochelle 345 kV transition substation consisting of six 345 kV air-insulated disconnect switches and rigid buses with the following major equipment:

- Six (6) sets of 345 kV open air, oil-filled cable terminators
- Associated trench and conduit system
- Associated foundations
- Associated steel support structures
- Stormwater fixtures
- Required earthwork, grading and finish stone
- New perimeter fence
- New station ground grid
- Required station lightning masts, lighting and security system
- Relays, panels, controls, comm equipment, as required
- Associated material and hardware, as required

SERVICE AGREEMENT NO. 2843

e. Barrett – East Garden City 345 kV line

The proposed 345 kV electric underground transmission line extends from the Barrett Substation in the Hamlet of Oceanside in the Town of Hempstead in Nassau County travels north and connecting to the East Garden City Substation in the Hamlet of Uniondale in the Town of Hempstead in Nassau County. The proposed route will be approximately 8.8 miles, utilizing 1-4000kcmil XLPE cable per phase with a summer rating of at least 819 MVA Normal/1064 MVA LTE/1474 MVA STE and a winter rating of at least 901 MVA Normal/1171 MVA LTE/1621 MVA STE.

Furnish and install:

- Approximately 8.8 miles of 4000kcmil XLPE cable
- Associated cable splices, link boxes and cable terminations
- Associated duct bank and manholes
- Associated grounding and miscellaneous materials

f. East Garden City – Shore Road 345 kV line

The proposed 345 kV electric underground transmission line extends from the East Garden City Substation in the Hamlet of Uniondale in the Town of Hempstead in Nassau County to the Shore Road Substation in the Glenwood Landing Hamlet in Nassau County. The proposed route will be approximately 10.3 miles, utilizing 1-4000kcmil XLPE cable per phase with a summer rating of at least is 819 MVA Normal/1064 MVA LTE/1474 MVA STE and a winter rating of at least 901 MVA Normal/1171 MVA LTE/1621 MVA STE.

Furnish and install:

- Approximately 10.3 miles of 4000kcmil XLPE cable
- Associated cable splices, link boxes and cable terminations
- Associated duct bank and manholes
- Associated grounding and miscellaneous materials

g. East Garden City – Tremont 345 kV line

The proposed 345 kV electric underground transmission line extends from the East Garden City Substation in the Hamlet of Uniondale in the Town of Hempstead in Nassau County to the Shore Road Substation in the Glenwood Landing Hamlet in Nassau County. The proposed route will be approximately 23.5 miles, utilizing 1-4000kcmil XLPE cable per phase with a summer rating of at least is 819 MVA Normal/1064 MVA LTE/1474 MVA STE and a winter rating of at least 901 MVA Normal/1171 MVA LTE/1621 MVA STE.

Furnish and install:

- Approximately 23.5 miles of 4000kcmil XLPE cable

SERVICE AGREEMENT NO. 2843

- Associated cable splices, link boxes and cable terminations
- Associated duct bank and manholes
- Associated grounding and miscellaneous materials

h. Ruland Road – Shore Road 345 kV line

The proposed 345 kV electric underground transmission line extends from the Ruland Road Substation in the Hamlet of Melville in the Town of Huntington in Suffolk County to the Shore Road Substation in the Glenwood Landing Hamlet in Nassau County. The proposed route will be approximately 17.8 miles, utilizing 1-4000kcmil XLPE cable per phase with a summer rating of at least is 819 MVA Normal/1064 MVA LTE/1474MVA STE and a winter rating of at least 901 MVA Normal/1171 MVA LTE/1621 MVA STE.

Furnish and install:

- Approximately 17.8 miles of 4000kcmil XLPE cable
- Associated cable splices, link boxes and cable terminations
- Associated duct bank and manholes
- Associated grounding and miscellaneous materials

i. Shore Road – Syosset 138 kV line

The proposed 138 kV electric underground transmission line begins at the Syosset Substation in the Hamlet of Woodbury in the Town of Oyster Bay in Nassau County leading to the Shore Road Substation in the Hamlet of Glenwood Landing in the Town of Oyster Bay in Nassau County. The proposed route will be approximately 11.3 miles, utilizing 1-4000 kcmil XLPE cable per phase with a summer rating of at least 360 MVA Normal/450 MVA LTE/566 MVA STE and a winter rating of at least 400 MVA Normal/500 MVA LTE/629 MVA STE.

Furnish and install:

- Approximately 11.3 miles of 4000kcmil XLPE cable
- Associated cable splices, link boxes and cable terminations
- Associated duct bank and manholes
- Associated grounding and miscellaneous materials

j. Two Shore Road – Sprain Brook 345 kV lines

Two proposed 345 kV electric underground transmission lines beginning at the Shore Road Substation in the Hamlet of Glenwood Landing in the Town of Oyster Bay in Nassau County. A marine segment is proposed from the Shore Road Substation to a landing point in New Rochelle across the Long Island Sound to the Sprain Brook Substation in the City of Yonkers, Westchester County. The proposed route will be approximately 18.1 miles, utilizing 4000 kcmil XLPE cable per phase for the onshore portions of the route and two tri-core 1400mm² (2760kcmil) Cu/XLPE/Pb/StSWA

SERVICE AGREEMENT NO. 2843

submarine cables for the offshore portions of the route with a summer rating of at least 819 MVA /1064 MVA LTE/1474 MVA STE per circuit and a winter rating of at least 901 MVA Normal/1171 MVA LTE/1621 MVA STE.

Furnish and install:

- Two (2) circuits of approximately 18.1 miles of 1-4000kcmil XLPE cable onshore and 2-1400mm² tri-core submarine cables
- Associated cable splices, link boxes and cable terminations
- Associated duct bank and manholes
- Associated grounding and miscellaneous materials
- A New Rochelle transition station consisting of six (6) 345 kV, 3000A, 120KA, manually operated, double break disconnect switches

2. Permitting – Licensing, Environmental, and Regulatory Approvals

In accordance with Section 3.9 of this Agreement, the Designated Entity shall be responsible for applying for and obtaining all necessary licensing, environmental, and regulatory approvals for the Designated Project. Such approvals may include the following:

- (a) Certificate of Environmental Compatibility and Public Need (“CECPN”) issued pursuant to Article VII of the New York State Public Service Law;
- (b) Certificate of Public Convenience and Necessity issued pursuant to Section 68 of the New York State Public Service Law;
- (c) Environmental Management and Construction Plan (“EM&CP”) from the New York State Public Service Commission following issuance of the Article VII Certificate;
- (d) Section 401 Water Quality Certification;
- (e) National/State Pollutant Discharge Elimination System General Permit from the United State Environmental Protection Agency or the New York State Department of Environmental Conservation (“NYSDEC”) for stormwater discharge during construction activities;
- (f) Easement to Use New York State Lands Under Water from the New York State Office of General Services, Bureau of Land Management;
- (g) Freshwater Wetlands Permit, Tidal Wetland Permit, and/or Article Protection of Waters Permit from the NYSDEC, Division of Environmental Permits and the Bureau of Energy Policy Management;
- (h) Coastal Zone Consistency Review and Local Waterfront Revitalization Plans from the New York State Department of State (“NYSDOS”);
- (i) Coastal Erosion Management Permit from the NYSDEC, Division of Water, Bureau of Flood Protection and Dam Safety;
- (j) Threatened and Endangered Species Clearance from the NYSDEC, NY Natural Heritage Program;

- (k) Nationwide or individual permit from the U.S. Army Corps of Engineers (“USACE”);
- (l) Section 106 – National Historic Preservation Act Compliance determination from the New York State Historic Preservation Office (“NYSHPO”);
- (m) Endangered Species Act Section 7 (“ESA”), Migratory Bird Treaty Act and Bald and Golden Eagle Protection Act consultation and Special Use Permit, if applicable, from United States Fish and Wildlife Service (“USFWS”);
- (n) Preservation Law 14.09 from the New York State Office of Parks, Recreation, and Historic Preservation or State Historic Preservation Office;
- (o) Native American Triable Group(s) consultation;
- (p) Railroad crossing permit(s) from the Long Island Railroad;
- (q) Determination from New York Department of Agriculture & Markets pursuant to Agriculture & Markets Law § 305(4);
- (r) Utility Work Permits from the New York State Department of Transportation (“NYSDOT”) (for work within State highway rights of way); and/or
- (s) Permits for local road opening, right of way work, and/or curb work from the applicable county or local municipality.

3. Site Control / Rights of Way Acquisition

The Designated Entity is responsible for obtaining the necessary real property and/or rights of way (“ROWS”) for the construction of the Designated Project in accordance with the milestones set forth in Appendix C of this Agreement.

4. Financing

The Designated Entity is responsible for obtaining the necessary financing for the design, engineering, procurement, installation, construction, testing, commissioning, and operation of the Designated Project in accordance with the milestone set forth in Appendix C of this Agreement.

5. Engineering and Design

The Designated Entity is responsible for preparing the engineering design work. All engineering design work must comply with the Applicable Reliability Requirements, in addition to all relevant guidelines and design standards, including, but not limited to:

- ANSI C2-2023 National Electrical Safety Code
- ASCE Manual of Practice 113 Substation Structure Design Guide
- IEEE Std. 80 Guide for Safety in AC Substation Grounding
- IEEE C37, Standard for substations and circuit breakers
- IEEE C57, Standard for power and transformers
- IEEE and ANSI standards for transmission lines and substations, as applicable

6. Estimated Cost

The cost estimate for the Designated Public Policy Project is documented in the Long Island Public Policy Transmission Planning Report, dated June 13, 2023, and subject to the voluntary Cost Cap as detailed in Appendix D of this Agreement and the Designated Entity's Cost Cap set forth in the project information submitted to the NYISO consistent with the provisions of the ISO OATT.

7. Other Requirements

This Agreement was executed prior to the completion of the Facilities Study for the Designated Project in the Transmission Interconnection Procedures under Attachment P, the execution of all necessary Transmission Project Interconnection Agreements for the Designated Project, and the receipt of all necessary regulatory approvals. As a result, the construction, interconnection, and operation of the Designated Project may require the construction of facilities and/or the assignment of responsibilities that differ from the preliminary design and assignment of responsibilities identified in this Appendix B. If the facilities identified through the Transmission Interconnection Procedures or the responsibilities associated with designing, engineering, procuring, installing, constructing, testing, and commissioning the identified facilities materially differ from this Appendix B, the Parties will amend this Agreement, as necessary, pursuant to the terms of this Agreement.

Appendix C

Development Schedule

The Designated Entity shall demonstrate to the NYISO that it timely meets the following Critical Path Milestones and Advisory Milestones and that such milestones remain in good standing. This Agreement is being executed prior to the completion of the Facilities Study under the Transmission Interconnection Procedures, the execution of a Transmission Project Interconnection Agreement, as applicable, and the receipt of regulatory approvals, which could affect the milestones set forth herein. In the event that the completion of the Transmission Interconnection Procedures, the execution of a Transmission Project Interconnection Agreement, or receipt of regulatory approvals materially affect a milestone set forth in this Appendix C, the Parties shall review the milestones and the Designated Entity shall seek to amend the milestone(s), as necessary, pursuant to the terms of this Agreement.

~~**Critical Path Milestones:** [To be developed with consideration of each of the work plan requirements submitted by the Designated Entity pursuant to Attachment C to the Public Policy Transmission Planning Process Manual and presented herein according to the sequence of the critical path. The NYISO anticipates that the Designated Entity's critical path schedule will include many of the example milestones set forth below and that most of the other example milestones will be included as Advisory Milestones. The composition and sequence of the Critical Path Milestones will differ depending on the Designated Entity's Designated Project and schedule.]~~

~~**Advisory Milestones:** [To include in Development Schedule other milestones (e.g., periodic project review meetings) that are not determined to be on the critical path, but that will be monitored by the Designated Entity and reported to NYISO.]~~

~~[Example Milestones:~~

- ~~● Interconnection studies (e.g. Optional Feasibility Study, System Impact Study, Facilities Study)~~
- ~~● Siting activities (e.g. locating line routing, access roads, and substation site location options)~~
- ~~● Environmental impact studies (relative to siting options)~~
- ~~● Engineering (initial)~~
- ~~● Permitting and regulatory activities (e.g. Certificate of Environmental Compatibility and Public Need)~~
- ~~● Public outreach plan~~
- ~~● Initiation of negotiation of key contracts and financing~~
- ~~● Acquisition of all necessary approvals and authorizations of Governmental Authorities, including identification of all required regulatory approvals~~
- ~~● Closing of project financing~~
- ~~● Completion of key contracts~~
- ~~● Engineering (detailed)~~
- ~~● Procurement of major equipment and materials~~
- ~~● Environmental management & construction plan (for Article VII certification)~~

SERVICE AGREEMENT NO. 2843

- ~~Acquisition of [all or %] required rights of way and property / demonstration of site control~~
- ~~Surveying and geotechnical assessment (relative to line and station layouts)~~
- ~~Execution, or filing of unexecuted version, of interconnection agreement~~
- ~~Engineering (completed)~~
- ~~Delivery of major electrical equipment~~
- ~~Line and substation site work including milestones for foundations, towers, conductor stringing, equipment delivery and installation, substation controls and communication, security, etc.~~
- ~~Construction outage and restoration coordination plan~~
- ~~Completion, verification and testing~~
- ~~Operating and maintenance agreements and instructions~~
- ~~In Service Date~~
- ~~Required Designated Project In Service Date~~
- ~~Required Transmission Project In Service Date, if different]~~

SERVICE AGREEMENT NO. 2843

Appendix D—Cost Cap

<u>Item</u>	<u>Milestone Description</u>	<u>Responsible Party(ies)</u>	<u>Type</u>	<u>Due Date</u>
<u>1</u>	<u>Submit proof of Insurance pursuant to Article 6</u>	<u>Designated Entity</u>	<u>Advisory</u>	<u>Within ten (10) days of the execution of this Agreement or the date on which the Agreement is filed with FERC</u>
<u>2</u>	<u>Commence public outreach plan</u>	<u>Designated Entity</u>	<u>Advisory</u>	<u>Complete</u>
<u>3</u>	<u>Commence Preliminary Engineering and Design</u>	<u>Designated Entity</u>	<u>Advisory</u>	<u>Complete</u>
<u>4</u>	<u>Commence land acquisition activities</u>	<u>Designated Entity</u>	<u>Advisory</u>	<u>Complete</u>
<u>5</u>	<u>Execute TIP Facilities Study Agreement for Queue No. 1289</u>	<u>Designated Entity(ies) NYISO Connecting Transmission Owner(s)¹</u>	<u>Advisory</u>	<u>6/30/2024</u>
<u>6</u>	<u>File NYISO Quarterly Report</u>	<u>Designated Entity</u>	<u>Advisory</u>	<u>6/15/2024</u>
<u>7</u>	<u>File NYISO Quarterly Report</u>	<u>Designated Entity</u>	<u>Advisory</u>	<u>9/15/2024</u>
<u>8</u>	<u>File NYISO Quarterly Report</u>	<u>Designated Entity</u>	<u>Advisory</u>	<u>12/15/2024</u>
<u>9</u>	<u>Complete negotiation of site access for field studies related to the Designated Project</u>	<u>Designated Entity</u>	<u>Advisory</u>	<u>12/31/2024</u>
<u>10</u>	<u>File Article VII CECPN Application</u>	<u>Designated Entity</u>	<u>Critical</u>	<u>12/31/2024</u>

¹ The Connecting Transmission Owners are Consolidated Edison Company of New York, Inc. (“Con Edison”), the New York Power Authority (“NYPA”), and the Long Island Power Authority (“LIPA”), which entities were identified in the System Impact Study for Queue No. 1289 and are listed in the milestones solely for informational purposes. Additional Connecting Transmission Owners or Affected Systems may be identified in the Facilities Study for Queue No. 1289 under Attachment P to the ISO OATT.

SERVICE AGREEMENT NO. 2843

<u>Item</u>	<u>Milestone Description</u>	<u>Responsible Party(ies)</u>	<u>Type</u>	<u>Due Date</u>
<u>11</u>	<u>File NYISO Quarterly Report</u>	<u>Designated Entity</u>	<u>Advisory</u>	<u>3/15/2025</u>
<u>12</u>	<u>File NYISO Quarterly Report</u>	<u>Designated Entity</u>	<u>Advisory</u>	<u>6/15/2025</u>
<u>13</u>	<u>Article VII CECPN Application deemed complete</u>	<u>NYPSC</u>	<u>Critical</u>	<u>6/30/2025</u>
<u>14</u>	<u>Submit annual construction outage and restoration coordination plan for 2026</u>	<u>Designated Entity</u>	<u>Advisory</u>	<u>8/31/2025</u>
<u>15</u>	<u>File NYISO Quarterly Report</u>	<u>Designated Entity</u>	<u>Advisory</u>	<u>9/15/2025</u>
<u>16</u>	<u>File NYISO Quarterly Report</u>	<u>Designated Entity</u>	<u>Advisory</u>	<u>12/15/2025</u>
<u>17</u>	<u>Notification to the NYISO of selected general construction contractor(s) for submarine transmission and that applicable contracting agreement(s) are fully executed</u>	<u>Designated Entity</u>	<u>Advisory</u>	<u>12/31/2025</u>
<u>18</u>	<u>Complete procurement of major electrical equipment and materials² for the Designated Entity-owned substations³</u>	<u>Designated Entity</u>	<u>Critical</u>	<u>12/31/2025</u>
<u>19</u>	<u>Complete procurement of major electrical equipment and materials for terrestrial cable</u>	<u>Designated Entity</u>	<u>Critical</u>	<u>12/31/2025</u>

² For purposes of the milestones set forth in this Appendix C, “major electrical equipment and materials” shall include submarine cables, terrestrial cables and towers, transformers, PARs, shunt reactors, and series reactors, as applicable. Further, “complete procurement” of major electric equipment and materials shall mean that the Designated Entity has a valid and effective purchase order, agreement, or commercially recognized instrument with a vendor for the design, manufacture, and/or delivery of such equipment and materials, and the Designated Entity has paid in full or made all applicable deposits for vendor to begin designing, manufacturing, and/or shipping such equipment and materials.

³ For purposes of the milestones set forth in this Appendix C, “Designated Entity-owned substations” shall include: New Shore Road 345 kV-138 kV substation, Ruland Road 345 kV-138 kV substation, and Barrett 345 kV substation.

SERVICE AGREEMENT NO. 2843

<u>Item</u>	<u>Milestone Description</u>	<u>Responsible Party(ies)</u>	<u>Type</u>	<u>Due Date</u>
<u>20</u>	<u>Approval of annual construction outage and restoration coordination plan for 2026⁴</u>	<u>NYISO Applicable Transmission Owner(s)</u>	<u>Advisory</u>	<u>12/31/2025</u>
<u>21</u>	<u>Execution of all Transmission Project Interconnection Agreement(s)</u>	<u>Designated Entity NYISO Connecting Transmission Owner(s)</u>	<u>Advisory</u>	<u>6/30/2026</u>
<u>22</u>	<u>Article VII CECPN granted</u>	<u>NYPSC</u>	<u>Critical</u>	<u>2/28/2026</u>
<u>23</u>	<u>File Section 68 application</u>	<u>Designated Entity</u>	<u>Advisory</u>	<u>2/28/2026</u>
<u>24</u>	<u>File NYISO Quarterly Report</u>	<u>Designated Entity</u>	<u>Advisory</u>	<u>3/15/2026</u>
<u>25</u>	<u>File EM&CP for East Garden City to Tremont transmission line construction segment</u>	<u>Designated Entity</u>	<u>Critical</u>	<u>3/31/2026</u>
<u>26</u>	<u>Apply for all federal and other permits or approvals for East Garden City to Tremont transmission line construction segment</u>	<u>Designated Entity</u>	<u>Advisory</u>	<u>4/30/2026</u>
<u>27</u>	<u>Status update meeting with NYISO to discuss Article VII CECPN</u>	<u>Designated Entity NYISO</u>	<u>Advisory</u>	<u>4/30/2026</u>
<u>28</u>	<u>File NYISO Quarterly Report</u>	<u>Designated Entity</u>	<u>Advisory</u>	<u>6/15/2026</u>
<u>29</u>	<u>Engineering design finalized for all Designated Entity-owned substations and the New Rochelle station and submitted to the NYISO</u>	<u>Designated Entity</u>	<u>Critical</u>	<u>6/30/2026</u>

⁴ For purposes of the milestones set forth in this Attachment C, the approval of an annual construction outage and restoration coordination plan for the upcoming year does not guarantee that there will not be subsequent modifications or cancellations of the requested outages and restorations by the NYISO or applicable Transmission Owner. The scheduling of all outages and restorations will be scheduled, modified, or cancelled pursuant to the requirements set forth in the NYISO's tariffs and procedures, including, but not limited to, the NYISO's Outage Scheduling Manual.

SERVICE AGREEMENT NO. 2843

<u>Item</u>	<u>Milestone Description</u>	<u>Responsible Party(ies)</u>	<u>Type</u>	<u>Due Date</u>
<u>30</u>	<u>Engineering design finalized for all submarine circuits of the Designated Project and submitted to the NYISO</u>	<u>Designated Entity</u>	<u>Critical</u>	<u>6/30/2026</u>
<u>31</u>	<u>Submit proposed protection for the BPS element to NPCC for approval (if applicable) to the NYISO</u>	<u>Designated Entity</u>	<u>Advisory</u>	<u>6/30/2026</u>
<u>32</u>	<u>NYPSC order approving EM&CP for East Garden City to Tremont transmission line segment</u>	<u>NYPSC</u>	<u>Critical</u>	<u>6/30/2026</u>
<u>33</u>	<u>Section 68 approval</u>	<u>NYPSC</u>	<u>Critical</u>	<u>6/30/2026</u>
<u>34</u>	<u>Completion of land acquisition activities⁵ for East Garden City to Tremont construction segment</u>	<u>Designated Entity</u>	<u>Advisory</u>	<u>7/31/2026</u>
<u>35</u>	<u>Submit annual construction outage and restoration coordination plan for 2027</u>	<u>Designated Entity</u>	<u>Advisory</u>	<u>8/31/2026</u>
<u>36</u>	<u>Notification to the NYISO of selected general construction contractor(s) for East Garden City to Tremont transmission line and that applicable contracting agreement(s) are fully executed</u>	<u>Designated Entity</u>	<u>Advisory</u>	<u>8/31/2026</u>
<u>37</u>	<u>File NYISO Quarterly Report</u>	<u>Designated Entity</u>	<u>Advisory</u>	<u>9/15/2026</u>

⁵ For purposes of the milestones set forth in this Appendix C, “completion of land acquisition activities” shall mean that the Designated Entity has obtained all necessary documentation demonstrating (i) ownership of a site, (ii) a leasehold interest in a site, or (iii) a right to develop a site for the purpose of constructing a transmission facility.

SERVICE AGREEMENT NO. 2843

<u>Item</u>	<u>Milestone Description</u>	<u>Responsible Party(ies)</u>	<u>Type</u>	<u>Due Date</u>
38	<u>Provide notice to the NYISO confirming that all major electrical equipment and materials for the New Shore Road substation are available⁶</u>	<u>Designated Entity</u>	<u>Advisory</u>	<u>9/30/2026</u>
39	<u>Provide notice to the NYISO confirming that all major electrical equipment and materials for the Ruland Road substation are available</u>	<u>Designated Entity</u>	<u>Advisory</u>	<u>9/30/2026</u>
40	<u>Construction mobilization⁷ for East Garden City to Tremont transmission line construction segment</u>	<u>Designated Entity</u>	<u>Critical</u>	<u>9/30/2026</u>
41	<u>File NYISO Quarterly Report</u>	<u>Designated Entity</u>	<u>Advisory</u>	<u>12/15/2026</u>
42	<u>Notification to the NYISO of selected general construction contractor(s) for New Shore Road substation and that applicable contracting agreement(s) are fully executed</u>	<u>Designated Entity</u>	<u>Advisory</u>	<u>12/31/2026</u>
43	<u>Notification to the NYISO of selected general construction contractor(s) for Ruland Road substation and that applicable contracting agreement(s) are fully executed</u>	<u>Designated Entity</u>	<u>Advisory</u>	<u>12/31/2026</u>

⁶ For purposes of this milestone, major electrical equipment and materials shall be “available” if they are (i) located on the appropriate construction site or designated marshalling yard(s) in reasonable proximity to the site where it will be installed, (ii) located in the Designated Entity’s warehouse or other inventory stocking location of the Designated Entity, or (iii) on order from the vendor with a scheduled delivery date prior to the time scheduled for its use in the applicable transmission facility.

⁷ For purposes of this milestone, “construction mobilization” means activation of the contractor’s physical and workforce resources to the construction site of any portion of the Transmission Project.

SERVICE AGREEMENT NO. 2843

<u>Item</u>	<u>Milestone Description</u>	<u>Responsible Party(ies)</u>	<u>Type</u>	<u>Due Date</u>
<u>44</u>	<u>Approval of annual construction outage and restoration coordination plan for 2027</u>	<u>NYISO Applicable Transmission Owner(s)</u>	<u>Advisory</u>	<u>12/31/2026</u>
<u>45</u>	<u>Commence construction of East Garden City to Tremont transmission line construction segment</u>	<u>Designated Entity</u>	<u>Critical</u>	<u>1/31/2027</u>
<u>46</u>	<u>Construction mobilization for the New Shore Road substation</u>	<u>Designated Entity</u>	<u>Critical</u>	<u>1/31/2027</u>
<u>47</u>	<u>Construction mobilization for the Ruland Road substation</u>	<u>Designated Entity</u>	<u>Critical</u>	<u>1/31/2027</u>
<u>48</u>	<u>File NYISO Quarterly Report</u>	<u>Designated Entity</u>	<u>Advisory</u>	<u>3/15/2027</u>
<u>49</u>	<u>Provide notice to the NYISO confirming that all major electrical equipment and materials for the Barrett 345 kV substation are available</u>	<u>Designated Entity</u>	<u>Advisory</u>	<u>3/31/2027</u>
<u>50</u>	<u>Notification to the NYISO of selected general construction contractor(s) for the Barrett 345 kV substation and that applicable contracting agreement(s) are fully executed</u>	<u>Designated Entity</u>	<u>Advisory</u>	<u>5/31/2027</u>
<u>51</u>	<u>File NYISO Quarterly Report</u>	<u>Designated Entity</u>	<u>Advisory</u>	<u>6/15/2027</u>
<u>52</u>	<u>Completion of land acquisition activities for the Designated Project</u>	<u>Designated Entity</u>	<u>Advisory</u>	<u>6/30/2027</u>
<u>53</u>	<u>Demonstrate adequate financing for the Designated Project to the NYISO⁸</u>	<u>Designated Entity</u>	<u>Critical</u>	<u>6/30/2027</u>

⁸ For purposes of the milestone, the Designated Entity shall demonstrate that it has access to sufficient capital reasonably necessary to complete the Designated Project.

SERVICE AGREEMENT NO. 2843

<u>Item</u>	<u>Milestone Description</u>	<u>Responsible Party(ies)</u>	<u>Type</u>	<u>Due Date</u>
<u>54</u>	<u>Construction mobilization for the Barrett 345 kV substation</u>	<u>Designated Entity</u>	<u>Critical</u>	<u>6/30/2027</u>
<u>55</u>	<u>Commence construction of the Ruland Road substation</u>	<u>Designated Entity</u>	<u>Critical</u>	<u>7/31/2027</u>
<u>56</u>	<u>Commence construction of the Barrett 345 kV substation</u>	<u>Designated Entity</u>	<u>Critical</u>	<u>7/31/2027</u>
<u>57</u>	<u>Submit an annual construction outage and restoration coordination plan for 2028</u>	<u>Designated Entity</u>	<u>Advisory</u>	<u>8/31/2027</u>
<u>58</u>	<u>File NYISO Quarterly Report</u>	<u>Designated Entity</u>	<u>Advisory</u>	<u>9/15/2027</u>
<u>59</u>	<u>Commence construction of the New Shore Road substation</u>	<u>Designated Entity</u>	<u>Critical</u>	<u>11/30/2027</u>
<u>60</u>	<u>File NYISO Quarterly Report</u>	<u>Designated Entity</u>	<u>Advisory</u>	<u>12/15/2027</u>
<u>61</u>	<u>Approval of construction outage and restoration coordination plan for 2028</u>	<u>NYISO Applicable Transmission Owner(s)</u>	<u>Advisory</u>	<u>12/31/2027</u>
<u>62</u>	<u>File NYISO Quarterly Report</u>	<u>Designated Entity</u>	<u>Advisory</u>	<u>3/15/2028</u>
<u>63</u>	<u>Provide notice to the NYISO confirming that all major electrical equipment and materials for the New Rochelle station are available</u>	<u>Designated Entity</u>	<u>Advisory</u>	<u>3/31/2028</u>
<u>64</u>	<u>Complete all environmental field studies for transmission and substation EM&CPs</u>	<u>Designated Entity</u>	<u>Advisory</u>	<u>3/31/2028</u>

SERVICE AGREEMENT NO. 2843

<u>Item</u>	<u>Milestone Description</u>	<u>Responsible Party(ies)</u>	<u>Type</u>	<u>Due Date</u>
<u>65</u>	<u>Notification to the NYISO of selected general construction contractor(s) for the New Rochelle station and that applicable contracting agreement(s) are fully executed</u>	<u>Designated Entity</u>	<u>Advisory</u>	<u>5/31/2028</u>
<u>66</u>	<u>File NYISO Quarterly Report</u>	<u>Designated Entity</u>	<u>Advisory</u>	<u>6/15/2028</u>
<u>67</u>	<u>Construction mobilization for the New Rochelle station</u>	<u>Designated Entity</u>	<u>Critical</u>	<u>6/30/2028</u>
<u>68</u>	<u>Obtain NPCC approval of the protection for the BPS element (if applicable)</u>	<u>Designated Entity</u>	<u>Advisory</u>	<u>6/30/2028</u>
<u>69</u>	<u>Commence construction of the New Rochelle station</u>	<u>Designated Entity</u>	<u>Critical</u>	<u>7/31/2028</u>
<u>70</u>	<u>Submit an annual construction outage and restoration coordination plan for 2029</u>	<u>Designated Entity</u>	<u>Advisory</u>	<u>8/31/2028</u>
<u>71</u>	<u>File NYISO Quarterly Report</u>	<u>Designated Entity</u>	<u>Advisory</u>	<u>9/15/2028</u>
<u>72</u>	<u>File Final EM&CP</u>	<u>Designated Entity</u>	<u>Critical</u>	<u>9/30/2028</u>
<u>73</u>	<u>File NYISO Quarterly Report</u>	<u>Designated Entity</u>	<u>Advisory</u>	<u>12/15/2028</u>
<u>74</u>	<u>Complete installation of conduit and/or cable for 45 cumulative miles of transmission lines</u>	<u>Designated Entity</u>	<u>Advisory</u>	<u>12/31/2028</u>
<u>75</u>	<u>Approval of construction outage and restoration coordination plan for 2029</u>	<u>NYISO Applicable Transmission Owner(s)</u>	<u>Advisory</u>	<u>12/31/2028</u>
<u>76</u>	<u>NYPSC order approving final EM&CP</u>	<u>NYPSC</u>	<u>Critical</u>	<u>1/31/2029</u>
<u>77</u>	<u>File NYISO Quarterly Report</u>	<u>Designated Entity</u>	<u>Advisory</u>	<u>3/15/2029</u>

SERVICE AGREEMENT NO. 2843

<u>Item</u>	<u>Milestone Description</u>	<u>Responsible Party(ies)</u>	<u>Type</u>	<u>Due Date</u>
<u>78</u>	<u>Complete installation of conduit and/or cable for 60 cumulative miles of transmission lines</u>	<u>Designated Entity</u>	<u>Advisory</u>	<u>3/31/2029</u>
<u>79</u>	<u>Engineering design finalized for all terrestrial transmission lines of the Designated Project and submitted to the NYISO</u>	<u>Designated Entity</u>	<u>Critical</u>	<u>4/30/2029</u>
<u>80</u>	<u>Complete installation of conduit and/or cable for 75 cumulative miles of transmission lines</u>	<u>Designated Entity</u>	<u>Advisory</u>	<u>5/31/2029</u>
<u>81</u>	<u>File NYISO Quarterly Report</u>	<u>Designated Entity</u>	<u>Advisory</u>	<u>6/15/2029</u>
<u>82</u>	<u>Construction mobilization for submarine transmission line</u>	<u>Designated Entity</u>	<u>Critical</u>	<u>6/30/2029</u>
<u>83</u>	<u>Submit an annual construction outage and restoration coordination plan for 2030</u>	<u>Designated Entity</u>	<u>Advisory</u>	<u>8/31/2029</u>
<u>84</u>	<u>Complete installation of conduit and/or cable for 90 cumulative miles of transmission lines</u>	<u>Designated Entity</u>	<u>Advisory</u>	<u>8/31/2029</u>
<u>85</u>	<u>File NYISO Quarterly Report</u>	<u>Designated Entity</u>	<u>Advisory</u>	<u>9/15/2029</u>
<u>86</u>	<u>File NYISO Quarterly Report</u>	<u>Designated Entity</u>	<u>Advisory</u>	<u>12/15/2029</u>
<u>87</u>	<u>Approval of construction outage and restoration coordination plan for 2030</u>	<u>NYISO Applicable Transmission Owner(s)</u>	<u>Advisory</u>	<u>12/31/2029</u>
<u>88</u>	<u>Completion of Network Upgrade Facilities identified in the TIP Facilities Study</u>	<u>Connecting Transmission Owner(s)</u>	<u>Advisory</u>	<u>12/31/2029</u>

SERVICE AGREEMENT NO. 2843

<u>Item</u>	<u>Milestone Description</u>	<u>Responsible Party(ies)</u>	<u>Type</u>	<u>Due Date</u>
<u>89</u>	<u>File NYISO Quarterly Report</u>	<u>Designated Entity</u>	<u>Advisory</u>	<u>3/15/2030</u>
<u>90</u>	<u>Construction completion for Designated Entity-owned substations and the New Rochelle station in the Designated Project⁹</u>	<u>Designated Entity</u>	<u>Critical</u>	<u>5/1/2030</u>
<u>91</u>	<u>Submit final energization plan to the NYISO and the Applicable Transmission Owner(s)</u>	<u>Designated Entity</u>	<u>Critical</u>	<u>Four (4) weeks prior to the final energization of the Designated Project</u>
<u>92</u>	<u>Construction completion of all transmission lines in the Designated Project</u>	<u>Designated Entity</u>	<u>Critical</u>	<u>5/15/2030</u>
<u>93</u>	<u>Perform final connections to the New York State Transmission System and complete verification and testing in accordance with the final energization plan</u>	<u>Designated Entity Connecting Transmission Owner(s)</u>	<u>Critical</u>	<u>5/29/2030¹⁰</u>
<u>94</u>	<u>Required Designated Project In-Service Date / Required Transmission Project Required In-Service Date</u>	<u>Designated Entity</u>	<u>Critical</u>	<u>5/31/2030</u>

⁹ For purposes of the milestones set forth in this Appendix C, “completion” means completion of all work necessary for the facilities to be ready for testing and may exclude the final construction work to connect such transmission facilities to the New York State Transmission System and testing activities.

¹⁰ This milestone shall be completed in accordance with the final energization plan but no later than two (2) calendar days prior to the Required Designated Project In-Service Date (i.e., Milestone No. 94).

Appendix D

Cost Cap

The Designated Entity submitted a soft Cost Cap for the Included Capital Costs (as defined in Section 31.4.5.1.8.1 of the ISO OATT) of the Designated Project as a part of its proposed solution to the Long Island Offshore Wind Export Public Policy Transmission Need. The NYISO considered the soft Cost Cap in selecting the Transmission Project as the more efficient or cost-effective solution. In accordance with Article 15.3 of the Agreement and the provisions of the ISO OATT, the details of the Designated Entity's Cost Cap for the Included Capital Costs of the Designated Project are set forth in this Appendix D.

Cost Cap

The Designated Entity's Cost Cap for the Included Capital Costs of the Designated Project equals \$2,639,763,454, which is based on the Included Capital Costs of \$2,553,950,711 plus an escalation factor of 2% per annum for the period of time between project submission (October 11, 2021) and project selection (June 20, 2023) as contained in the Designated Entity's submittal in the NYISO's Public Policy Transmission Planning Process. Except as provided in Article 15.3 of this Agreement or Section 6.10.6.3 of the ISO OATT, responsibility for Included Capital Costs, as defined in Section 31.4.5.1.8.1 of the ISO OATT, greater than this Cost Cap will be shared between the Designated Entity and ratepayers based on the cost sharing percentage set forth below. As permitted by Section 31.4.5.1.8 of the ISO OATT, the Designated Entity made the following elections in defining certain real estate costs as Included Capital Costs:

- Real estate costs for existing rights of way that are related to transmission lines but are not owned by the Designated Entity are not included in the Included Capital Costs.

Cost Cap Risk Sharing

The defined percentage for the sharing of Included Capital Costs greater than the Cost Cap between the Designated Entity and ratepayers is as follows:

Designated Entity's Responsibility = 20% of Included Capital Costs above the Cost Cap

Ratepayers' Responsibility = 80% of Included Capital Costs above the Cost Cap

As required by Article 15.3 of this Agreement, the Designated Entity further agrees to implement the Cost Cap in accordance with Section 6.10.6.3 of Rate Schedule 10.

Cost Cap Excusing Conditions

Consistent with Article 15.3 of the Agreement, the Designated Entity may recover costs above its agreed-upon Cost Cap resulting from one of the following excusing conditions but only to the extent the costs arise from one or more of the following excusing condition:

SERVICE AGREEMENT NO. 2843

1. Designated Project changes, delays, or additional costs that are due to the actions or omissions of the NYISO, Connecting Transmission Owner(s), Interconnecting Transmission Owner(s), Affected Transmission Owner(s), or other Designated Entity(ies) responsible for completing other parts of the Transmission Project;
2. A Force Majeure event as defined in this Agreement and subject to the Force Majeure requirements in Section 15.5 of this Agreement;
3. Changes in laws or regulations, including but not limited to applicable taxes;
4. Material modifications to scope or routing arising from siting processes under Public Service Law Article VII or applicable local laws as determined by the New York State Public Service Commission or local governments respectively; and
5. Actions or inactions of regulatory or governmental entities, and court orders.