

SERVICE AGREEMENT NO. 2514

SERVICE AGREEMENT NO. 2514
FIRST AMENDED AND RESTATED DEVELOPMENT AGREEMENT
AMONG
THE NEW YORK INDEPENDENT SYSTEM OPERATOR, INC.
AND
LS POWER GRID NEW YORK CORPORATION I
AND
NEW YORK POWER AUTHORITY

Dated as of December 28, 2023

SERVICE AGREEMENT NO. 2514

TABLE OF CONTENTS

	<u>Page</u>
ARTICLE 1. DEFINITIONS	3
ARTICLE 2. EFFECTIVE DATE AND TERM.....	7
2.1. Effective Date	7
2.2. Filing	7
2.3. Term of Agreement.....	7
ARTICLE 3. TRANSMISSION PROJECT DEVELOPMENT AND CONSTRUCTION	7
3.1. Application for Required Authorizations and Approvals.....	7
3.2. Development and Construction of Transmission Project.....	8
3.3. Milestones	8
3.4. Modifications to Required Project In-Service Date	9
3.5. Modifications to Transmission Project.....	10
3.6. Billing and Payment.....	11
3.7. Project Monitoring.....	11
3.8. Right to Inspect.....	11
3.9. Exclusive Responsibility of Developer	11
3.10. Subcontractors	12
3.11. No Services or Products Under NYISO Tariffs.....	12
3.12. Tax Status	12
3.13. Joint and Several Liability.....	12
ARTICLE 4. COORDINATION WITH THIRD PARTIES.....	13
4.1. Interconnection Requirements for Transmission Project	13
4.2. Interconnection with Affected System	13
4.3. Coordination of Interregional Transmission Project.....	13
ARTICLE 5. OPERATION REQUIREMENTS FOR THE TRANSMISSION PROJECT	14
ARTICLE 6. INSURANCE	14
ARTICLE 7. BREACH AND DEFAULT	16
7.1. Breach	16
7.2. Default.....	17
7.3. Remedies	17
ARTICLE 8. TERMINATION	18
8.1. Termination by the NYISO.....	18
8.2. Reporting of Inability to Comply with Provisions of Agreement.....	18

8.3. Transmission Project Transfer Rights Upon Termination.....19

SERVICE AGREEMENT NO. 2514

ARTICLE 9. LIABILITY AND INDEMNIFICATION 19

 9.1. Liability 19

 9.2. Indemnity..... 19

ARTICLE 10. ASSIGNMENT 20

ARTICLE 11. INFORMATION EXCHANGE AND CONFIDENTIALITY 21

 11.1. Information Access 21

 11.2. Confidentiality 21

ARTICLE 12. REPRESENTATIONS, WARRANTIES AND COVENANTS 22

 12.1. General 22

 12.2. Good Standing 22

 12.3. Authority 22

 12.4. No Conflict 22

 12.5. Consent and Approval..... 22

 12.6. Compliance with All Applicable Laws and Regulations 23

ARTICLE 13. DISPUTE RESOLUTION 23

ARTICLE 14. SURVIVAL 23

ARTICLE 15. MISCELLANEOUS..... 23

 15.1. Notices..... 23

 15.2. Entire Agreement..... 24

 15.3. Cost Recovery..... 24

 15.4. Binding Effect..... 25

 15.5. Force Majeure..... 25

 15.6. Disclaimer 25

 15.7. No NYISO Liability for Review or Approval of Developer Materials 25

 15.8. Amendment 26

 15.9. No Third Party Beneficiaries..... 26

 15.10. Waiver 26

 15.11. Rules of Interpretation 26

 15.12. Severability..... 27

 15.13. Multiple Counterparts 27

 15.14. No Partnership 27

 15.15. Headings..... 27

 15.16. Governing Law 27

15.17. Jurisdiction and Venue.....27

SERVICE AGREEMENT NO. 2514

APPENDICES

APPENDIX A	Project Description
APPENDIX B	Scope of Work
APPENDIX C	Development Schedule

SERVICE AGREEMENT NO. 2514

THIS FIRST AMENDED AND RESTATED DEVELOPMENT AGREEMENT

(“Agreement”) is made and entered into this 28th day of December 2023, by and between LS Power Grid New York Corporation I, organized and existing under the laws of the State of New York (formerly known as North America Transmission Corporation) (“LS Power”), the New York Power Authority, a corporate municipal instrumentality organized and existing under the laws of the State of New York (“NYPA”), and the New York Independent System Operator, Inc., a not-for-profit corporation organized and existing under the laws of the State of New York (“NYISO”). LS Power and NYPA are collectively referred to as the “Developer.” Developer and NYISO each may be individually referred to as a “Party” or collectively referred to as the “Parties.”

RECITALS

WHEREAS, the NYISO administers the Comprehensive System Planning Process (“CSPP”) in the New York Control Area pursuant to the terms set forth in Attachment Y of the NYISO’s Open Access Transmission Tariff (“OATT”), as accepted by the Federal Energy Regulatory Commission (“FERC”);

WHEREAS, as part of the CSPP, the NYISO administers a Public Policy Transmission Planning Process pursuant to which Public Policy Transmission Need(s) are identified; proposed solutions to the identified need(s) are solicited by the NYISO; and the more efficient or costeffective transmission solution to satisfy the identified need(s) is selected by the NYISO and reported in the NYISO’s Public Policy Transmission Planning Report;

WHEREAS, the Developer has proposed a Public Policy Transmission Project to satisfy an identified Public Policy Transmission Need (“Transmission Project”);

WHEREAS, the NYISO has selected the Developer’s Transmission Project as the more efficient or cost-effective transmission solution to satisfy an identified Public Policy Transmission Need and has directed Developer to proceed with the Transmission Project;

WHEREAS, the Developer has agreed to obtain the required authorizations and approvals from Governmental Authorities needed for the Transmission Project, to develop and construct the Transmission Project, and to abide by the related requirements in Attachment Y of the OATT, the ISO Tariffs, and the ISO Procedures;

WHEREAS, the Developer and the NYISO entered into a Development Agreement, dated as of February 3, 2020 and identified as Service Agreement No. 2514 (the “Original Agreement”), pursuant to Section 31.4.12.2 of Attachment Y of the OATT for the purpose of ensuring that the Transmission Project will be constructed and in service in time to satisfy the Public Policy Transmission Need (“Required Project In-Service Date”);

WHEREAS, the Developer has agreed to construct, and the NYISO has requested that the Developer proceed with construction of, the Transmission Project to address the identified Public Policy Transmission Need by the Required Project In-Service Date; and

SERVICE AGREEMENT NO. 2514

WHEREAS, the Developer requested, and the NYISO consented to, certain Significant Modifications to the Transmission Project and an extension of the Required Project In-Service Date, and the Parties have determined to amend and restate the Original Agreement to (i) incorporate the consented to Significant Modifications, as well as other non-Significant Modifications to the Transmission Project, (ii) incorporate a revised Required Project In-Service Date and modifications to the development schedule, and (iii) update contact information for notices.

SERVICE AGREEMENT NO. 2514

NOW, THEREFORE, in consideration of and subject to the mutual covenants contained herein, it is agreed:

ARTICLE 1. DEFINITIONS

Whenever used in this Agreement with initial capitalization, the following terms shall have the meanings specified in this Article 1. Terms used in this Agreement with initial capitalization that are not defined in this Article 1 shall have the meanings specified in Section 31.1.1 of Attachment Y of the OATT or, if not therein, in Article 1 of the OATT.

Advisory Milestones shall mean the milestones set forth in the Development Schedule in Attachment C to this Agreement that are not Critical Path Milestones.

Affected System Operator shall mean any Affected System Operator(s) identified in connection with the Transmission Project pursuant to Attachment P of the ISO OATT.

Applicable Laws and Regulations shall mean: (i) all duly promulgated applicable federal, state and local laws, regulations, rules, ordinances, codes, decrees, judgments, directives, or judicial or administrative orders, permits and other duly authorized actions of any Governmental Authority, and (ii) all applicable requirements of the ISO Tariffs, ISO Procedures, and ISO Related Agreements.

Applicable Reliability Organizations shall mean the NERC, the NPCC, and the NYSRC.

Applicable Reliability Requirements shall mean the requirements, criteria, rules, standards, and guidelines, as they may be amended and modified and in effect from time to time, of: (i) the Applicable Reliability Organizations, (ii) the Connecting Transmission Owner(s), and (iii) any Affected System Operator; provided, however, that no Party shall waive its right to challenge the applicability or validity of any requirement, criteria, rule, standard, or guideline as applied to it in the context of this Agreement.

Breach shall have the meaning set forth in Article 7.1 of this Agreement.

Breaching Party shall mean a Party that is in Breach of this Agreement.

Business Day shall mean Monday through Friday, excluding federal holidays.

Calendar Day shall mean any day including Saturday, Sunday, or a federal holiday.

Change of Control shall mean a change in ownership of more than 50% of the membership or ownership interests or other voting securities of LS Power or NYPA to a third party in one or more related transactions, or any other transaction that has the effect of transferring control of LS Power or NYPA to a third party.

Confidential Information shall mean any information that is defined as confidential by Article

SERVICE AGREEMENT NO. 2514

Connecting Transmission Owner shall be the Connecting Transmission Owner(s) identified in connection with the Transmission Project pursuant to Attachment P of the ISO OATT.

Critical Path Milestones shall mean the milestones identified as such in the Development Schedule in Attachment C to this Agreement that must be met for the Transmission Project to be constructed and operating by the Required Project In-Service Date.

Default shall mean the failure of a Party in Breach of this Agreement to cure such Breach in accordance with Article 7.2 of this Agreement.

Developer shall have the meaning set forth in the introductory paragraph.

Development Schedule shall mean the schedule of Critical Path Milestones and Advisory Milestones set forth in Appendix C to this Agreement.

Effective Date shall mean the date upon which this Agreement becomes effective as determined in Article 2.1 of this Agreement.

FERC shall mean the Federal Energy Regulatory Commission or its successor.

Force Majeure shall mean any act of God, labor disturbance, act of the public enemy, war, insurrection, riot, fire, storm or flood, explosion, breakage or accident to machinery or equipment, any order, regulation or restriction imposed by governmental, military or lawfully established civilian authorities, or any other cause beyond a Party's control. A Force Majeure event does not include acts of negligence or intentional wrongdoing by the Party claiming Force Majeure.

Good Utility Practice shall mean any of the practices, methods and acts engaged in or approved by a significant portion of the electric industry during the relevant time period, or any of the practices, methods and acts which, in the exercise of reasonable judgment in light of the facts known at the time the decision was made, could have been expected to accomplish the desired result at a reasonable cost consistent with good business practice, reliability, safety and expedition. Good Utility Practice is not intended to be limited to the optimum practice, method, or act to the exclusion of all others, but rather to delineate acceptable practices, methods, or acts generally accepted in the region.

Governmental Authority shall mean any federal, state, local or other governmental regulatory or administrative agency, public authority, court, commission, department, board, or other governmental subdivision, legislature, rulemaking board, tribunal, or other governmental authority having jurisdiction over any of the Parties, their respective facilities, or the respective services they provide, and exercising or entitled to exercise any administrative, executive, police, or taxing authority or power; *provided, however*, that such term does not include the NYISO, the Developer, the Connecting Transmission Owner(s), the Affected System Operator(s), or any Affiliate thereof.

SERVICE AGREEMENT NO. 2514

In-Service Date shall mean the date upon which the Transmission Project is energized consistent with the provisions of the Transmission Project Interconnection Agreement and available to provide Transmission Service under the NYISO Tariffs.

ISO/TO Agreement shall mean the *Agreement Between the New York Independent System Operator and Transmission Owners*, as filed with and accepted by the Commission in *Cent. Hudson Gas & Elec. Corp., et al.*, 88 FERC ¶ 61,138 (1999) in Docket Nos. ER97-1523, *et al.*, and as amended or supplemented from time to time, or any successor agreement thereto.

New York State Transmission System shall mean the entire New York State electrical transmission system, which includes: (i) the Transmission Facilities Under ISO Operational Control; (ii) the Transmission Facilities Requiring ISO Notification; and (iii) all remaining transmission facilities within the New York Control Area.

NERC shall mean the North American Electric Reliability Corporation or its successor organization.

NPCC shall mean the Northeast Power Coordinating Council or its successor organization.

NYPSC shall mean the New York State Public Service Commission or its successor.

NYSRC shall mean the New York State Reliability Council or its successor organization.

OATT shall mean the NYISO's Open Access Transmission Tariff, as filed with the Commission, and as amended or supplemented from time to time, or any successor tariff thereto.

Party or Parties shall have the meaning set forth in the introductory paragraph.

Point of Interconnection shall mean the point or points at which the Developer's Transmission Project will interconnect to the New York State Transmission System.

Project Description shall mean the description of the Transmission Project set forth in Appendix A to this Agreement that is consistent with the project proposed and evaluated in the NYISO's Public Policy Transmission Planning Process and selected by the NYISO Board of Directors as the more efficient or cost-effective transmission solution to the identified Public Policy Transmission Need.

Public Policy Transmission Planning Process Manual shall mean the NYISO's manual adopted by the NYISO stakeholder Operating Committee describing the NYISO's procedures for implementing the Public Policy Transmission Planning Process component of the NYISO's Comprehensive System Planning Process, as the manual is amended or supplemented from time to time, or any successor manual thereto.

Required Project In-Service Date shall mean the In-Service Date by which the Transmission Project must be constructed and operating, which date shall be: (i) the date by which the Public Policy Transmission Need must be satisfied as prescribed by the NYPSC in its order identifying

SERVICE AGREEMENT NO. 2514

the need or in a subsequent order, or (ii) if the NYPSC has not prescribed a date, the date proposed by the Developer and reviewed and accepted by the NYISO, which date may be either: (A) the In-Service Date specified by the Developer in the project information it submitted under Attachment Y of the OATT for use by the NYISO in its selection of the Transmission Project as the more efficient or cost-effective transmission solution to satisfy the Public Policy Transmission Need, or (B) such other date accepted by the NYISO as reasonable in light of the Public Policy Transmission Need. The Required Project In-Service Date is set forth in the Development Schedule contained in Appendix C to this Agreement.

Services Tariff shall mean the NYISO's Market Administration and Control Area Services Tariff, as filed with the Commission, and as amended or supplemented from time to time, or any successor tariff thereto.

Significant Modification shall mean the Developer's proposed modification to its Transmission Project that: (i) could impair the Transmission Project's ability to meet the identified Public Policy Transmission Need, (ii) could delay the In-Service Date of the Transmission Project beyond the Required Project In-Service Date, or (iii) would constitute a material change to the project information submitted by the Developer under Attachment Y of the OATT for use by the NYISO in evaluating the Transmission Project for purposes of selecting the more efficient or cost-effective transmission solution to meet the identified Public Policy Transmission Need.

Scope of Work shall mean the description of the work required to implement the Transmission Project as set forth in Appendix B to this Agreement. The Scope of Work shall be drawn from the Developer's submission of the "Information for a Proposed Solution to a Public Policy Transmission Need" and the "Data Submission for Public Policy Transmission Projects," which are set forth in Attachments B and C of the NYISO Public Policy Transmission Planning Process Manual, as may be updated as agreed upon by the Parties. The Scope of Work shall include, but not be limited to, a description of: the acquisition of required rights-of-ways, the work associated with the licensing, design, financing, environmental and regulatory approvals, engineering, procurement of equipment, construction, installation, testing, and commissioning of the Transmission Project; the relevant technical requirements, standards, and guidelines pursuant to which the work will be performed; the major equipment and facilities to be constructed and/or installed in connection with the Transmission Project, and the cost estimates for the work associated with the Transmission Project.

Transmission Owner Technical Standards shall mean the technical requirements and standards (*e.g.*, equipment or facilities electrical and physical capabilities, design characteristics, or construction requirements), as those requirements and standards are amended and modified and in effect from time to time, of: (i) the Connecting Transmission Owner(s), and (ii) any Affected System Operator.

Transmission Project shall mean the Developer's proposed Public Policy Transmission Project selected by the NYISO as the more efficient or cost-effective transmission solution to a Public Policy Transmission Need that is subject to this Agreement, as described in the Project Description set forth in Appendix A to this Agreement.

SERVICE AGREEMENT NO. 2514

ARTICLE 2. EFFECTIVE DATE AND TERM

2.1. Effective Date

This Agreement shall become effective on the date it has been executed by all Parties; *provided, however*, if the Agreement is filed with FERC as a non-conforming or an unexecuted agreement pursuant to Section 31.4.12.2 of Attachment Y of the OATT, the Agreement shall become effective on the effective date accepted by FERC.

2.2. Filing

If the Agreement must be filed with FERC pursuant to Section 31.4.12.2 of Attachment Y of the OATT, the NYISO shall file this Agreement for acceptance with FERC within the timeframe set forth for the filing in Section 31.4.12.2 of Attachment Y of the OATT. The Developer shall cooperate in good faith with the NYISO with respect to such filing and provide any information requested by the NYISO to comply with Applicable Laws and Regulations. Any Confidential Information shall be treated in accordance with Article 11.2 of this Agreement.

2.3. Term of Agreement

Subject to the termination provisions in Article 8 of this Agreement, this Agreement shall remain in effect from the Effective Date until: (i) LS Power and NYPA each has an executed operating agreement with the NYISO or is a party to the ISO/TO Agreement, as applicable, and (ii) the Transmission Project: (A) has been completed in accordance with the terms and conditions of this Agreement, and (B) is in-service; *provided, however*, that the terms of this Agreement shall continue in effect to the extent provided in Article 14 of this Agreement.

ARTICLE 3. TRANSMISSION PROJECT DEVELOPMENT AND CONSTRUCTION

3.1. Application for Required Authorizations and Approvals

The Developer shall timely seek and obtain all authorizations and approvals from Governmental Authorities required to develop, construct, and operate the Transmission Project by the Required Project In-Service Date. The required authorizations and approvals shall be listed in the Scope of Work in Appendix B to this Agreement. The Developer shall seek and obtain the required authorizations and approvals in accordance with the milestones set forth in the Development Schedule in Appendix C to this Agreement. The milestones for obtaining the required authorizations and approvals shall be included in the Development Schedule as Critical Path Milestones and Advisory Milestones, as designated by the Parties under Article 3.3.1. The Developer shall notify the NYISO in accordance with the notice requirements in Article 3.3 if it has reason to believe that it may be unable to timely obtain or is denied an approval or authorization by a Governmental Authority required for the development, construction, or operation of the Transmission Project, or if such approval or authorization is withdrawn or modified.

SERVICE AGREEMENT NO. 2514

3.2. Development and Construction of Transmission Project

The Developer shall design, engineer, procure, install, construct, test and commission the Transmission Project in accordance with: (i) the terms of this Agreement, including, but not limited to, the Project Description in Appendix A to this Agreement, the Scope of Work in Appendix B to this Agreement, and the Development Schedule in Appendix C to this Agreement; (ii) Applicable Reliability Requirements; (iii) Applicable Laws and Regulations; (iv) Good Utility Practice; (v) the Transmission Owner Technical Standards, and (vi) any interconnection agreement(s) entered into by and among the NYISO, Developer, and Connecting Transmission Owner(s) for the Transmission Project to interconnect to the New York State Transmission System.

3.3. Milestones

- 3.3.1. The NYISO shall provide the Developer with the Required Project In-Service Date that is set forth in the Public Policy Transmission Planning Report in accordance with Section 31.4.11 of Attachment Y of the OATT. Prior to executing and/or filing this Agreement with FERC, the NYISO and the Developer shall agree to the Critical Path Milestones and Advisory Milestones set forth in the Development Schedule in Appendix C to this Agreement for the development, construction, and operation of the Transmission Project by the Required Project In-Service Date in accordance with Section 31.4.12.2 of Attachment Y of the OATT; provided that any such milestone for the Transmission Project that requires action by a Connecting Transmission Owner or Affected System Operator to complete must be included as an Advisory Milestone.
- 3.3.2. The Developer shall meet the Critical Path Milestones in accordance with the Development Schedule set forth in Appendix C to this Agreement. The Developer's inability or failure to meet a Critical Path Milestone specified in the Development Schedule, as such Critical Path Milestone may be amended with the agreement of the NYISO under this Article 3.3, shall constitute a Breach of this Agreement under Article 7.1.
- 3.3.3. The Developer shall notify the NYISO thirty (30) Calendar Days prior to the date of each Critical Path Milestone specified in the Development Schedule whether, to the best of its knowledge, it expects to meet the Critical Path Milestone by the specified date; *provided, however*, that notwithstanding this requirement:
- (i) the Developer shall notify the NYISO as soon as reasonably practicable, and no later than fifteen (15) Calendar Days, following either LS Power's or NYPA's discovery of a potential delay in meeting a Critical Path Milestone, including a delay caused by a Force Majeure event; and
 - (ii) the NYISO may request in writing at any time, and the Developer shall submit to the NYISO within five (5) Business Days of the request, a written response indicating whether the Developer will meet, or has met, a Critical Path Milestone and providing all required supporting documentation for its response.

SERVICE AGREEMENT NO. 2514

- 3.3.4. The Developer shall not make a change to a Critical Path Milestone without the prior written consent of the NYISO. To request a change to a Critical Path Milestone, the Developer must: (i) inform the NYISO in writing of the proposed change to the Critical Path Milestone and the reason for the change, including the occurrence of a Force Majeure event in accordance with Section 15.5, (ii) submit to the NYISO a revised Development Schedule containing any necessary changes to Critical Path Milestones and Advisory Milestones that provide for the Transmission Project to be completed and achieve its In-Service Date no later than the Required Project In-Service Date, and (iii) submit a notarized officer's certificate certifying the Developer's capability to complete the Transmission Project in accordance with the modified schedule. If the Developer: (i) must notify the NYISO of a potential delay in meeting a Critical Path Milestone in accordance with one of the notification requirements in Section 3.3.3 or (ii) is requesting a change to a Critical Path Milestone to cure a Breach in Section 7.2, the Developer shall submit any request to change the impacted Critical Path Milestone(s) within the relevant notification timeframe set forth in Section 3.3.3 or the cure period set forth in Section 7.2, as applicable. The NYISO will promptly review the Developer's requested change. The Developer shall provide the NYISO with all required information to assist the NYISO in making its determination and shall be responsible for the costs of any study work the NYISO performs in making its determination. If the Developer demonstrates to the NYISO's satisfaction that the delay in meeting a Critical Path Milestone will not delay the Transmission Project's In-Service Date beyond the Required Project In-Service Date, then the NYISO's consent to extending the Critical Path Milestone date will not be unreasonably withheld, conditioned, or delayed. The NYISO's written consent to a revised Development Schedule proposed by the Developer will satisfy the amendment requirements in Article 15.8, and the NYISO will not be required to file the revised Development Schedule with FERC.
- 3.3.5. Within fifteen (15) Calendar Days of either LS Power's or NYPA's discovery of a potential delay in meeting an Advisory Milestone, the Developer shall inform the NYISO of the potential delay and describe the impact of the delay on meeting the Critical Path Milestones. The Developer may extend an Advisory Milestone date upon informing the NYISO of such change; *provided, however*, that if the change to the Advisory Milestone will delay a Critical Path Milestone, the NYISO's written consent to make such change is required as described in Article 3.3.4.

3.4. Modifications to Required Project In-Service Date

- 3.4.1. The Developer shall not make a change to the Required Project In-Service Date without the prior written consent of the NYISO. To request a change, the Developer must: (i) inform the NYISO in writing of the proposed change to the Required Project In-Service Date and the reason for the change, including the occurrence of a Force Majeure event, (ii) submit to the NYISO a revised Development Schedule that provides for the Transmission Project to be completed and achieve its In-Service Date no later than the proposed, modified Required Project In-Service Date, and (iii) demonstrate that the Developer has made reasonable progress against the milestones set forth in the

NYISO Agreements --> Service Agreements --> Development Agreement Segment A, NYISO, LS Power, NYPA

Development Schedule, and is capable of completing the Transmission Project in accordance with the modified schedule. If the Required Project In-Service Date is the

SERVICE AGREEMENT NO. 2514

date prescribed by the NYPSC in its order identifying the Public Policy Transmission Need or in a subsequent order, the Developer must also demonstrate that the NYPSC has issued an order modifying its prescribed date.

3.4.2. The NYISO will promptly review Developer's requested change to the Required Project In-Service Date. The Developer shall provide the NYISO with all required information to assist the NYISO in making its determination and shall be responsible for the costs of any study work the NYISO performs in making its determination. If the Developer fails to provide the NYISO with the information required to make its determination, the NYISO shall not be obligated to make this determination. The NYISO's consent to extend the Required Project In-Service Date will not be unreasonably withheld, conditioned, or delayed if the Developer demonstrates to the NYISO's satisfaction that: (i) its proposed modified Required Project In-Service Date is reasonable in light of the Public Policy Transmission Need, (ii) it has made reasonable progress against the milestones set forth in the Development Schedule, and (iii) its proposed modified date will not result in a significant adverse impact to the reliability of the New York State Transmission System. The Parties shall amend this Agreement in accordance with Article 15.8 to incorporate a revised Required Project In-Service Date and Development Schedule.

3.5. Modifications to Transmission Project

The Developer shall not make a Significant Modification to the Transmission Project without the prior written consent of the NYISO, including, but not limited to, modifications necessary for the Developer to obtain required approvals or authorizations from Governmental Authorities; *provided, however*, that a proposed Significant Modification that is a proposed modification to the Required Project In-Service Date shall be addressed in accordance with Article 3.4. The NYISO's determination regarding a Significant Modification to the Transmission Project under this Agreement shall be separate from, and shall not replace, the NYISO's review and determination of material modifications to the Transmission Project under Attachment P of the OATT. The Developer may request that the NYISO review whether a modification to the Transmission Project would constitute a Significant Modification. The Developer shall provide the NYISO with all required information to assist the NYISO in making its determination regarding a Significant Modification and shall be responsible for the costs of any study work the NYISO must perform in making its determination. The NYISO's consent to the Significant Modification will not be unreasonably withheld, conditioned, or delayed if the Developer demonstrates to the NYISO's satisfaction that its proposed Significant Modification: (i) does not impair the Transmission Project's ability to satisfy the identified Public Policy Transmission Need, (ii) does not delay the In-Service Date of the Transmission Project beyond the Required Project In-Service Date, (iii) does not change the grounds upon which the NYISO selected the Transmission Project as the more efficient or cost-effective transmission solution to the identified Public Policy Transmission Need, and (iv) will not result in a significant adverse impact to the reliability of the New York State Transmission System. The NYISO's performance of this review shall not constitute its consent to delay the completion of any Critical Path Milestone.

SERVICE AGREEMENT NO. 2514

3.6. Billing and Payment

The NYISO shall charge, and the Developer shall pay, the actual costs of: (i) any study work performed by the NYISO or its subcontractor(s) under Articles 3.3, 3.4, and 3.5, or (ii) any assessment of the Transmission Project by the NYISO or its subcontractor(s) under Article 3.8. LS Power and NYPA shall identify a single billing and payment contact for the Developer, and the NYISO will invoice the Developer by sending invoices to that billing and payment contact at the notice address for such contact set forth in Article 15.1. The NYISO will invoice the Developer by sending invoices to the billing and payment contact on a monthly basis for the expenses incurred by the NYISO each month, including estimated subcontractor costs, computed on a time and material basis. The NYISO shall not be required to allocate charges to the Developer between LS Power and NYPA. LS Power and NYPA shall resolve between themselves how such charges shall be allocated between themselves. The Developer shall pay invoiced amounts to the NYISO within thirty (30) Calendar Days of the NYISO's issuance of a monthly invoice. In the event the Developer disputes an amount to be paid, the Developer shall pay the disputed amount to the NYISO, pending resolution of the dispute. To the extent the dispute is resolved in the Developer's favor, the NYISO will net the disputed amount, including interest calculated from Developer's date of payment at rates applicable to refunds under FERC regulations, against any current amounts due from the Developer and pay the balance to the Developer. This Article 3.6 shall survive the termination, expiration, or cancellation of this Agreement.

3.7. Project Monitoring

The Developer shall provide regular status reports to the NYISO in accordance with the monitoring requirements set forth in the Development Schedule, the Public Policy Transmission Planning Process Manual and Attachment Y of the OATT.

3.8. Right to Inspect

Upon reasonable notice, the NYISO or its subcontractor shall have the right to inspect the Transmission Project for the purpose of assessing the progress of the development and construction of the Transmission Project and satisfaction of milestones. The exercise or non-exercise by the NYISO or its subcontractor of this right shall not be construed as an endorsement or confirmation of any element or condition of the development or construction of the Transmission Project, or as a warranty as to the fitness, safety, desirability or reliability of the same. Any such inspection shall take place during normal business hours, shall not interfere with the construction of the Transmission Project and shall be subject to such reasonable safety and procedural requirements as the Developer shall specify.

3.9. Exclusive Responsibility of Developer

As between the Parties, the Developer shall be solely responsible for all planning, design, engineering, procurement, construction, installation, management, operations, safety, and compliance with Applicable Laws and Regulations, Applicable Reliability Requirements, and

NYISO Agreements --> Service Agreements --> Development Agreement Segment A, NYISO, LS Power, NYPA

Transmission Owner Technical Standards associated with the Transmission Project, including, but not limited to, scheduling, meeting Critical Path Milestones and Advisory Milestones, timely

SERVICE AGREEMENT NO. 2514

requesting review and consent to any project modifications, and obtaining all necessary permits, siting, and other regulatory approvals. The NYISO shall have no responsibility and shall have no liability regarding the management or supervision of the Developer's development of the Transmission Project or the compliance of the Developer with Applicable Laws and Regulations, Applicable Reliability Requirements, and Transmission Owner Technical Standards. The NYISO shall cooperate with the Developer in good faith in providing information to assist the Developer in obtaining all approvals and authorizations from Governmental Authorities required to develop, construct, and operate the Transmission Project by the Required Project In-Service Date, including, if applicable, information describing the NYISO's basis for selecting the Transmission Project as the more efficient or cost-effective transmission solution to satisfy an identified Public Policy Transmission Need.

3.10. Subcontractors

3.10.1. Nothing in this Agreement shall prevent a Party from using the services of any subcontractor as it deems appropriate to perform its obligations under this Agreement; *provided, however*, that each Party shall require, and shall provide in its contracts with its subcontractors, that its subcontractors comply with all applicable terms and conditions of this Agreement in providing such services; *provided, further*, that each Party shall remain primarily liable to the other Party for the performance of such subcontractor.

3.10.2. The creation of any subcontractor relationship shall not relieve the hiring Party of any of its obligations under this Agreement. The hiring Party shall be fully responsible to the other Party for the acts or omissions of any subcontractor the hiring Party hires as if no subcontract had been made.

3.11. No Services or Products Under NYISO Tariffs

This Agreement does not constitute a request for, nor agreement by the NYISO to provide, Transmission Service, interconnection service, Energy, Ancillary Services, Installed Capacity, Transmission Congestion Contracts or any other services or products established under the ISO Tariffs. If Developer wishes to receive or supply such products or services, the Developer must make application to do so under the applicable provisions of the ISO Tariffs, ISO Related Agreements, and ISO Procedures.

3.12. Tax Status

Each Party shall cooperate with the other Party to maintain each Party's tax status to the extent the Party's tax status is impacted by this Agreement. Nothing in this agreement is intended to affect the tax status of any Party.

3.13 Joint and Several Liability

LS Power and NYPA are jointly and severally liable for all obligations of the Developer under this Agreement.

SERVICE AGREEMENT NO. 2514

ARTICLE 4. COORDINATION WITH THIRD PARTIES

4.1. Interconnection Requirements for Transmission Project

The Developer shall satisfy all requirements set forth in the Transmission Interconnection Procedures in Attachment P of the OATT applicable to a “Transmission Project” to interconnect the Transmission Project to the New York State Transmission System by the Required Project In-Service Date, including, but not limited to, submitting a Transmission Interconnection Application; participating in all necessary studies; executing, and/or requesting the NYISO to file for FERC acceptance, a Transmission Project Interconnection Agreement; and constructing, or arranging for the construction of, all required Network Upgrade Facilities; *provided, however*, if the Developer began the interconnection process in Attachment X of the OATT or the transmission expansion process in Sections 3.7 or 4.5 of the OATT prior to the effective date of the Transmission Interconnection Procedures, the Developer shall satisfy the requirements of the Transmission Interconnection Procedures in accordance with the transition rules in Section 22.3.3 of Attachment P of the OATT.

If the NYISO determines that the proposed interconnection of a “Transmission Project” under Attachment P could affect the Transmission Project under this Agreement, the Developer shall participate in the Transmission Interconnection Procedures as an Affected System Operator in accordance with the requirements set forth in Section 22.4.4 of Attachment P. If the NYISO determines that the proposed interconnection of a “Large Generating Facility,” “Small Generating Facility,” or “Class Year Transmission Project” under Attachments X or Z of the OATT could affect the Transmission Project, the Developer shall participate in the interconnection process as an Affected System Operator in accordance with the requirements set forth in Section 30.3.5 of Attachment X of the OATT. If the NYISO determines that a proposed transmission expansion under Sections 3.7 and 4.5 of the OATT could affect the Transmission Project, the Developer shall participate in the transmission expansion process as an affected Transmission Owner in accordance with the requirements set forth in Sections 3.7 and 4.5 of the OATT.

4.2. Interconnection with Affected System

If part of the Transmission Project will affect the facilities of an Affected System as determined in Attachment P of the OATT, the Developer shall satisfy the requirements of the Affected System Operator for the interconnection of the Transmission Project.

4.3. Coordination of Interregional Transmission Project

If the Transmission Project is or seeks to become an Interregional Transmission Project selected by the NYISO and by the transmission provider in one or more neighboring transmission planning region(s) to address an identified Public Policy Transmission Need, the Developer shall coordinate its development and construction of the Transmission Project in New York with its responsibilities in the relevant neighboring transmission planning region(s) and must satisfy the applicable planning requirements of the relevant transmission planning region(s).

SERVICE AGREEMENT NO. 2514

ARTICLE 5. OPERATION REQUIREMENTS FOR THE TRANSMISSION PROJECT

NYPA shall comply with the operating requirements set forth in the ISO/TO Agreement with respect to all elements of the Transmission Project operated by NYPA. As and to the extent necessary for the Transmission Project, LS Power shall: (i) execute, and/or obtain a FERC accepted, interconnection agreement for the Transmission Project in accordance with the requirements in Attachment P of the OATT; (ii) satisfy the applicable requirements set forth in the interconnection agreement and ISO Procedures for the safe and reliable operation of the Transmission Project consistent with the Project Description set forth in Appendix A by the In-Service Date, including satisfying all applicable testing, metering, communication, system protection, switching, start-up, and synchronization requirements; (iii) enter into required operating protocols as determined by the NYISO; (iv) register with NERC as a Transmission Owner and Transmission Planner; (v) register and be certified as a Transmission Operator if LS Power is operating the Transmission Project or any portion thereof; (vi) comply with all NERC Reliability Standards and Applicable Reliability Requirements applicable to Transmission Owners, Transmission Planners, and, if LS Power is operating the Transmission Project or any portion thereof, Transmission Operators; and (vii) prior to energizing the Transmission Project, execute an operating agreement with the NYISO.

ARTICLE 6. INSURANCE

LS Power and NYPA shall each, at their own expense, maintain in force throughout the period of this Agreement, and until released by the NYISO, the following minimum insurance coverages, with insurers authorized to do business in the state of New York and rated “A-(minus) VII” or better by A.M. Best & Co. (or if not rated by A.M. Best & Co., a rating entity acceptable to the NYISO):

6.1 Workers’ Compensation and Employers’ Liability Insurance providing statutory benefits in accordance with the laws and regulations of New York State under NCCI Coverage Form No. WC 00 00 00, as amended or supplemented from time to time, or an equivalent form acceptable to the NYISO; *provided, however*, if the Transmission Project will be located in part outside of New York State, LS Power and NYPA shall each maintain such Employers’ Liability Insurance coverage with a minimum limit of One Million Dollars (\$1,000,000).

6.2 Commercial General Liability Insurance - under ISO Coverage Form No. CG 00 01 (04/13), as amended or supplemented from time to time, or an equivalent form acceptable to the NYISO - with minimum limits of Two Million Dollars (\$2,000,000) per occurrence/Four Million Dollars (\$4,000,000) aggregate combined single limit for personal injury, bodily injury, including death and property damage.

6.3 Commercial Business Automobile Liability Insurance - under ISO Coverage Form No. CA 00 01 10 13, as amended or supplemented from time to time, or an equivalent form acceptable to the NYISO - for coverage of owned and non-owned and hired vehicles, trailers or semi-trailers designed for travel on public roads, with a minimum, combined single limit of One Million Dollars (\$1,000,000) per occurrence for bodily injury, including death, and property damage.

SERVICE AGREEMENT NO. 2514

6.4 Umbrella/Excess Liability Insurance over and above the Employers' Liability, Commercial General Liability, and Commercial Business Automobile Liability Insurance coverage, with a minimum combined single limit of Twenty-Five Million Dollars (\$25,000,000) per occurrence/Twenty-Five Million Dollars (\$25,000,000) aggregate.

6.5 Builder's Risk Insurance in a reasonably prudent amount consistent with Good Utility Practice.

6.6 The Commercial General Liability Insurance, Commercial Business Automobile Liability Insurance and Umbrella/Excess Liability Insurance policies of LS Power and NYPA shall name the NYISO and its respective directors, officers, agents, servants and employees ("NYISO Parties") as additional insureds. For Commercial General Liability Insurance, LS Power and NYPA shall name the NYISO Parties as additional insureds under the following ISO form numbers, as amended or supplemented from time to time, or an equivalent form acceptable to the NYISO: (i) ISO Coverage Form No. CG 20 37 04 13 ("Additional Insured - Owners, Lessees or Contractors - Completed Operations") and (ii) (A) ISO Coverage Form No. CG 20 10 04 13 ("Additional Insured - Owner, Lessees or Contractors - Scheduled Person or Organization"), or (B) ISO Coverage Form No. CG 20 26 04 13 ("Additional Insured - Designated Person or Organization"). For Commercial Business Automobile Liability Insurance, LS Power and NYPA shall name the NYISO Parties as additional insureds under ISO Coverage Form No. CA 20 48 10 13 ("Designated Insured for Covered Autos Liability Coverage"), as amended or supplemented from time to time, or an equivalent form acceptable to the NYISO.

6.7 All policies shall contain provisions whereby the insurers waive all rights of subrogation in accordance with the provisions of this Agreement against the NYISO Parties and provide thirty (30) Calendar days advance written notice to the NYISO Parties prior to non-renewal, cancellation or any material change in coverage or condition.

6.8 The Commercial General Liability Insurance, Commercial Business Automobile Liability Insurance and Umbrella/Excess Liability Insurance policies shall contain provisions that specify that the policies are primary and shall apply to such extent without consideration for other policies separately carried and shall state that each insured is provided coverage as though a separate policy had been issued to each, except each insurer's liability shall not be increased beyond the amount for which that insurer would have been liable had only one insured been covered. LS Power and NYPA shall be responsible for their respective deductibles or retentions.

6.9 The Commercial General Liability Insurance, Commercial Business Automobile Liability Insurance and Umbrella/Excess Liability Insurance policies, if written on a Claims First Made Basis in a form acceptable to the NYISO, shall be maintained in full force and effect for two (2) years after termination of this Agreement, which coverage may be in the form of an extended reporting period (ERP) or a separate policy, if agreed by each of LS Power and NYPA and the NYISO.

6.10 The requirements contained herein as to the types and limits of all insurance to be maintained by LS Power and NYPA are not intended to and shall not in any manner, limit or qualify the liabilities and obligations assumed by LS Power and NYPA, under this Agreement.

SERVICE AGREEMENT NO. 2514

6.11 LS Power and NYPA shall each provide certification of all insurance required in this Agreement, executed by each insurer or by an authorized representative of each insurer: (A) within ten (10) days following: (i) execution of this Agreement, or (ii) the NYISO's date of filing this Agreement if it is filed unexecuted with FERC, and (B) as soon as practicable after the end of each fiscal year or at the renewal of the insurance policy and in any event within thirty (30) days thereafter.

6.12 Notwithstanding the foregoing, LS Power and NYPA each, as applicable, may self-insure to meet the minimum insurance requirements of Articles 6.1 through 6.9 to the extent it maintains a self-insurance program; *provided that*, its respective senior debt is rated at investment grade, or better, by Standard & Poor's and that its respective self-insurance program meets the minimum insurance requirements of Articles 6.1 through 6.9. For any period of time that either of LS Power's or NYPA's senior debt is unrated by Standard & Poor's or is rated at less than investment grade by Standard & Poor's, LS Power or NYPA, as applicable, shall comply with the insurance requirements applicable to it under Articles 6.1 through 6.9. In the event that LS Power or NYPA, as applicable, are permitted to self-insure pursuant to this Article 6.12, LS Power or NYPA, as applicable, shall notify the NYISO that it meets the requirements to self-insure and that its self-insurance program meets the minimum insurance requirements in a manner consistent with that specified in Article 6.11.

6.13 The Developer and the NYISO agree to report to each other in writing as soon as practical all accidents or occurrences resulting in injuries to any person, including death, and any property damage arising out of this Agreement.

6.14 Notwithstanding the minimum insurance coverage types and amounts described in this Article 6, LS Power and NYPA: (i) shall also maintain any additional insurance coverage types and amounts required under Applicable Laws and Regulations, including New York State law, and under Good Utility Practice for the work performed by the Developer and its subcontractors under this Agreement, and (ii) shall satisfy the requirements set forth in Articles 6.6 through 6.13 with regard to the additional insurance coverages, including naming the NYISO Parties as additional insureds under these policies.

ARTICLE 7. BREACH AND DEFAULT

7.1. Breach

A Breach of this Agreement shall occur when: (i) the Developer notifies the NYISO in writing that it will not proceed to develop the Transmission Project for reasons other than those set forth in Articles 8.1(i) through (iv); (ii) the Developer fails to meet a Critical Path Milestone, as the milestone may be extended with the agreement of the NYISO under Article 3.3.4 of this Agreement, set forth in the Development Schedule in Appendix C to this Agreement; (iii) the Developer makes a Significant Modification to the Transmission Project without the prior written consent of the NYISO; (iv) the Developer fails to pay a monthly invoice within the timeframe set forth in Article 3.6; (v) the Developer misrepresents a material fact of its representations and warranties set forth in Article 12; (vi) a Party assigns this Agreement in a

manner inconsistent with the terms of Article 10 of this Agreement; (vii) the Developer fails to comply with any other material term or condition of this Agreement; (viii) a custodian, receiver,

SERVICE AGREEMENT NO. 2514

trustee or liquidator of LS Power or NYPA, or of all or substantially all of the assets of LS Power or NYPA, is appointed in any proceeding brought by LS Power or NYPA; or (ix) any such custodian, receiver, trustee, or liquidator is appointed in any proceeding brought against LS Power or NYPA that is not discharged within ninety (90) Days after such appointment, or if LS Power or NYPA consents to or acquiesces in such appointment. A Breach shall not occur as a result of a Force Majeure event in accordance with Article 15.5. A Breach shall also not occur as a result of a delay caused by a Connecting Transmission Owner or an Affected System Operator.

7.2. Default

Upon a Breach, the non-Breaching Party shall give written notice of the Breach to the Breaching Party describing in reasonable detail the nature of the Breach and, where known and applicable, the steps necessary to cure such Breach, including whether and what such steps must be accomplished to complete the Transmission Project by the Required Project In-Service Date. The Breaching Party shall have thirty (30) Calendar Days from receipt of the Breach notice to cure the Breach, or such other period of time as may be agreed upon by the Parties, which agreement the NYISO will not unreasonably withhold, condition, or delay if it determines a longer cure period will not threaten the Developer's ability to complete the Transmission Project by the Required Project In-Service Date; *provided, however*, that if the Breach is the result of a Developer's inability or failure to meet a Critical Path Milestone, the Developer may only cure the Breach if either: (i) it meets the Critical Path Milestone within the cure period and demonstrates to the NYISO's satisfaction that, notwithstanding its failure to timely meet the Critical Path Milestone, the Transmission Project will achieve its In-Service Date no later than the Required Project In-Service Date, or (ii) the Developer requests in writing within the cure period, and the NYISO consents to, a change to the missed Critical Path Milestone in accordance with Article 3.3.4. If the Breach is cured within such timeframe, the Breach specified in the notice shall cease to exist. If the Breaching Party does not cure its Breach within this timeframe or cannot cure the Breach in a manner that provides for the Transmission Project to be completed by the Required Project In-Service Date, the non-Breaching Party shall have the right to declare a Default and terminate this Agreement pursuant to Article 8.1.

7.3. Remedies

Upon the occurrence of an event of Default, the non-defaulting Party shall be entitled: (i) to commence an action to require the defaulting Party to remedy such Default and specifically perform its duties and obligations hereunder in accordance with the terms and conditions hereof; and (ii) to exercise such other rights and remedies as it may have in equity or at law; *provided, however*, the defaulting Party's liability under this Agreement shall be limited to the extent set forth in Article 9.1. No remedy conferred by any provision of this Agreement is intended to be exclusive of any other remedy and each and every remedy shall be cumulative and shall be in addition to every other remedy given hereunder or now or hereafter existing at law or in equity or by statute or otherwise. The election of any one or more remedies shall not constitute a waiver of the right to pursue other available remedies. This Article 7.3 shall survive the termination, expiration, or cancellation of this Agreement.

SERVICE AGREEMENT NO. 2514

ARTICLE 8. TERMINATION

8.1. Termination by the NYISO

The NYISO may terminate this Agreement by providing written notice of termination to the Developer in the event that: (i) the Developer notifies the NYISO that it is unable to or has not received the required approvals or authorizations by Governmental Authorities required to develop, construct, and operate the Transmission Project by the Required Project In-Service Date; (ii) the Developer notifies the NYISO that its required approvals or authorizations by Governmental Authorities have been withdrawn by the Governmental Authorities; (iii) the Developer cannot complete the Transmission Project by the Required Project In-Service Date for any reason: (A) including the occurrence of a Force Majeure event that will prevent the Developer from completing the Transmission Project by the Required Project In-Service Date, but (B) excluding a delay caused by a Connecting Transmission Owner or an Affected System Operator; or (iv) the NYISO declares a default pursuant to Article 7.2 of this Agreement.

If the NYISO identifies grounds for termination under Articles 8.1(iii) or (iv) or receives notice from the Developer under Articles 8.1(i) or (ii), the NYISO may, prior to providing a written notice of termination, take action in accordance with Section 31.4.12.3.1.3 of Attachment Y of the OATT to address the Public Policy Transmission Need and, notwithstanding the confidentiality provisions in Article 11.2, may disclose information regarding the Transmission Project to Governmental Authorities as needed to implement such action. If the NYISO decides to terminate this Agreement under Article 8.1(i), (ii), (iii), or (iv), it will provide written notice of termination to the Developer, which notice will specify the date of termination. If the Agreement was filed and accepted by FERC pursuant to Section 31.4.12.2 of Attachment Y of the OATT, the NYISO will, following its provision of a notice of termination to the Developer, promptly file with FERC for its acceptance a notice of termination of this Agreement.

In the event of termination under Articles 8.1(i) or (ii), the Developer may be eligible for cost recovery under the OATT in the manner set forth in Attachment Y and Schedule 10 of the OATT. In the event of termination under Articles 8.1(iii) or (iv), cost recovery may be permitted as determined by FERC. In the event of termination for any reason under this Article 8.1, the Developer shall use commercially reasonable efforts to mitigate the costs, damages, and charges arising as a consequence of termination and any transfer or winding up of the Transmission Project.

8.2. Reporting of Inability to Comply with Provisions of Agreement

Notwithstanding the notification requirements in Article 3 and this Article 8 of this Agreement, each Party shall notify the other Party promptly upon the notifying Party becoming aware of its inability to comply with any provision of this Agreement. The Parties agree to cooperate with each other and provide necessary information regarding such inability to comply, including the date, duration, reason for inability to comply, and corrective actions taken or planned to be taken with respect to such inability to comply.

SERVICE AGREEMENT NO. 2514

8.3. Transmission Project Transfer Rights Upon Termination

If the NYISO terminates this Agreement pursuant to Article 8.1, the NYISO shall have the right, but shall not be required, to request an entity other than the Developer to complete the Transmission Project. The NYISO may exercise this right by providing the Developer with written notice within sixty (60) days after the date on which this Agreement is terminated. If the NYISO exercises its right under this Article 8.3 and Section 31.4.12.3.1.3 of Attachment Y of the OATT, the Developer shall work cooperatively with the NYISO's designee pursuant to the requirements set forth in Section 31.4.12.3.1.4 of Attachment Y of the OATT to implement the transition, including entering into good faith negotiations with the NYISO's designee to transfer the Transmission Project to the NYISO's designee. All liabilities under this Agreement existing prior to such transfer shall remain with the Developer, unless otherwise agreed upon by the Developer and the NYISO's designee as part of their good faith negotiations regarding the transfer. This Article 8.3 shall survive the termination, expiration, or cancellation of this Agreement.

ARTICLE 9. LIABILITY AND INDEMNIFICATION

9.1. Liability

Notwithstanding any other provision in the NYISO's tariffs and agreements to the contrary, neither Party shall be liable, whether based on contract, indemnification, warranty, equity, tort, strict liability, or otherwise, to the Other Party or any Transmission Owner, NYISO Market Participant, third party or any other person for any damages whatsoever, including, without limitation, direct, incidental, consequential (including, without limitation, attorneys' fees and litigation costs), punitive, special, multiple, exemplary, or indirect damages arising or resulting from any act or omission under this Agreement, except in the event the Party is found liable for gross negligence or intentional misconduct in the performance of its obligations under this Agreement, in which case the Party's liability for damages shall be limited only to direct actual damages. This Article 9.1 shall survive the termination, expiration, or cancellation of this Agreement.

9.2. Indemnity

Notwithstanding any other provision in the NYISO's tariffs and agreements to the contrary, each Party shall at all times indemnify and save harmless, as applicable, the other Party, its directors, officers, employees, trustees, and agents or each of them from any and all damages (including, without limitation, any consequential, incidental, direct, special, indirect, exemplary or punitive damages and economic costs), losses, claims, including claims and actions relating to injury to or death of any person or damage to property, liabilities, judgments, demands, suits, recoveries, costs and expenses, court costs, attorney and expert fees, and all other obligations by or to third parties, arising out of, or in any way resulting from this Agreement, *provided, however*, that the Developer shall not have any indemnification obligation under this Article 9.2 with respect to any loss to the extent the loss results from the gross negligence or intentional misconduct of the NYISO; *provided, further*, that the NYISO shall only have an

NYISO Agreements --> Service Agreements --> Development Agreement Segment A, NYISO, LS Power, NYPA
indemnification obligation under this Article 9.2 with respect to any loss resulting from its gross negligence or intentional misconduct to the same extent as provided in Section 2.11.3(b) of the

SERVICE AGREEMENT NO. 2514

ISO OATT. This Article 9.2 shall survive the termination, expiration, or cancellation of this Agreement.

ARTICLE 10. ASSIGNMENT

This Agreement may be assigned by a Party only with the prior written consent of the other Party; *provided that*:

- (i) any Change of Control of either LS Power and NYPA shall be considered an assignment under this Article 10 and shall require the other Party's prior written consent;
- (ii) an assignment by the Developer shall be contingent upon the Developer or assignee demonstrating to the satisfaction of the NYISO prior to the effective date of the assignment that: (A) the assignee has the technical competence, financial ability, and materials, equipment, and plans to comply with the requirements of this Agreement and to construct and place in service the Transmission Project by the Required Project InService Date consistent with the assignor's cost estimates for the Transmission Project; and (B) the assignee satisfies the requirements for a qualified developer pursuant to Section 31.4.4 of Attachment Y of the OATT; and
- (iii) the Developer shall have the right to assign this Agreement, without the consent of the NYISO, for collateral security purposes to aid in providing financing for the Transmission Project and shall promptly notify the NYISO of any such assignment; *provided, however*, that such assignment shall be subject to the following: (i) prior to or upon the exercise of the secured creditor's, trustee's, or mortgagee's assignment rights pursuant to said arrangement, the secured creditor, the trustee, or the mortgagee will notify the NYISO of the date and particulars of any such exercise of assignment right(s), and (ii) the secured creditor, trustee, or mortgagee must demonstrate to the satisfaction of the NYISO that any entity that it proposes to complete the Transmission Project meets the requirements for the assignee of a Developer described in Article 10(ii).

LS Power and NYPA may assign this Agreement to the other party only with the prior written consent of the other party and the NYISO, provided that the assignee must meet the requirements set forth in Article 10(ii).

For all assignments by any Party, the assignee must assume in a writing, to be provided to the other Party, all rights, duties, and obligations of the assignor arising under this Agreement, including the insurance requirements in Article 6 of this Agreement. Any assignment under this Agreement shall not relieve a Party of its obligations, nor shall a Party's obligations be enlarged, in whole or in part, by reasons thereof, absent the written consent of the other Parties. Where required, consent to assignment will not be unreasonably withheld, conditioned, or delayed. Any attempted assignment that violates this Article 10 is void and ineffective, is a Breach of this Agreement under Article 7.1 and may result in the termination of this Agreement under Articles 8.1 and 7.2.

SERVICE AGREEMENT NO. 2514

ARTICLE 11. INFORMATION EXCHANGE AND CONFIDENTIALITY

11.1. Information Access

Subject to Applicable Laws and Regulations, each Party shall make available to the other Party information necessary to carry out obligations and responsibilities under this Agreement and Attachment Y of the OATT. The Parties shall not use such information for purposes other than to carry out their obligations or enforce their rights under this Agreement or Attachment Y of the OATT.

11.2. Confidentiality

11.2.1. Confidential Information shall mean: (i) all detailed price information and vendor contracts; (ii) any confidential and/or proprietary information provided by one Party to the other Party that is clearly marked or otherwise designated “Confidential Information”; and (iii) information designated as Confidential Information by the NYISO Code of Conduct contained in Attachment F of the OATT; *provided, however*, that Confidential Information does not include information: (i) in the public domain or that has been previously publicly disclosed; (ii) required by an order of a Governmental Authority to be publicly submitted or divulged (after notice to the other Party); or (iii) necessary to be divulged in an action to enforce this Agreement.

11.2.2. The NYISO shall treat any Confidential Information it receives in accordance with the requirements of the NYISO Code of Conduct contained in Attachment F of the OATT. If the Developer receives Confidential Information, it shall hold such information in confidence, employing at least the same standard of care to protect the Confidential Information obtained from the NYISO as it employs to protect its own Confidential Information. Each Party shall not disclose the other Party’s Confidential Information to any third party or to the public without the prior written authorization of the Party providing the information, except: (i) to the extent required for the Parties to perform their obligations under this Agreement, the ISO Tariffs, ISO Related Agreements, or ISO Procedures, or (ii) to fulfill legal or regulatory requirements, provided that if the Party must submit the information to a Governmental Authority in response to a request by the Governmental Authority on a confidential basis, the Party required to disclose the information shall request under applicable rules and regulations that the information be treated as confidential and non-public by the Governmental Authority. If NYPA receives a request for disclosure of Confidential Information pursuant to Section 87(2)(d) of the New York Public Officers Law, NYPA shall provide prompt notice to the other parties to afford an opportunity to address the confidential nature of the information provided and will undertake reasonable efforts to protect the information from disclosure to the extent such information is exempt from disclosure under Section 87(2)(d) of the New York Public Officers Law.

SERVICE AGREEMENT NO. 2514

ARTICLE 12. REPRESENTATIONS, WARRANTIES AND COVENANTS

12.1. General

LS Power and NYPA each make the following representations, warranties, and covenants, which are effective as to LS Power or NYPA, as applicable, during the full time this Agreement is effective. For purposes of this Article 12, references to “Developer” mean LS Power or NYPA individually, as applicable, rather than collectively.

12.2. Good Standing

The Developer is duly organized, validly existing and in good standing under the laws of the state in which it is organized, formed, or incorporated, as applicable. The Developer is qualified to do business in the state or states in which the Transmission Project is located. The Developer has the corporate power and authority to own its properties, to carry on its business as now being conducted and to enter into this Agreement and carry out the transactions contemplated hereby and to perform and carry out covenants and obligations on its part under and pursuant to this Agreement.

12.3. Authority

The Developer has the right, power, and authority to enter into this Agreement, to become a Party hereto, and to perform its obligations hereunder. This Agreement is a legal, valid, and binding obligation of the Developer, enforceable against the Developer in accordance with its terms, except as the enforceability thereof may be limited by applicable bankruptcy, insolvency, reorganization, or other similar laws affecting creditors’ rights generally and by general equitable principles (regardless of whether enforceability is sought in a proceeding in equity or at law).

12.4. No Conflict

The execution, delivery and performance of this Agreement does not violate or conflict with the organizational or formation documents, or bylaws or operating agreement, of the Developer, or any judgment, license, permit, order, material agreement or instrument applicable to or binding upon the Developer or any of its assets.

12.5. Consent and Approval

The Developer has sought or obtained, or, in accordance with this Agreement will seek or obtain, such consent, approval, authorization, order, or acceptance by any Governmental Authority in connection with the execution, delivery and performance of this Agreement, and it will provide to any Governmental Authority notice of any actions under this Agreement that are required by Applicable Laws and Regulations.

SERVICE AGREEMENT NO. 2514

12.6. Compliance with All Applicable Laws and Regulations

The Developer will comply with all Applicable Laws and Regulations, including all approvals, authorizations, orders, and permits issued by any Governmental Authority; all Applicable Reliability Requirements, and all applicable Transmission Owner Technical Standards in the performance of its obligations under this Agreement.

ARTICLE 13. DISPUTE RESOLUTION

If a dispute arises under this Agreement between the Developer and the NYISO, the Parties shall use the dispute resolution process described in Article 11 of the NYISO's Services Tariff, as such process may be amended from time to time. Notwithstanding the process described in Article 11 of the NYISO's Services Tariff, the NYISO may terminate this Agreement in accordance with Article 8 of this Agreement. Any dispute that arises between LS Power and NYPA related to the performance of this Agreement is not covered by this Article 13 and shall be resolved outside of this Agreement by LS Power and NYPA without the NYISO's required involvement.

ARTICLE 14. SURVIVAL

The rights and obligations of the Parties in this Agreement shall survive the termination, expiration, or cancellation of this Agreement to the extent necessary to provide for the determination and enforcement of said obligations arising from acts or events that occurred while this Agreement was in effect. The remedies and rights and obligation upon termination provisions in Articles 7.3 and 8.3 of this Agreement, the liability and indemnity provisions in Article 9, and the billing and payment provisions in Article 3.6 of this Agreement shall survive termination, expiration, or cancellation of this Agreement.

ARTICLE 15. MISCELLANEOUS

15.1. Notices

Developer shall designate a project manager, authorized to receive and provide all notices that are required or that may be sent under the terms of this Agreement. Notice by the NYISO to the designated project manager constitutes notice to both LS Power and NYPA, and notice from the designated project manager to the NYISO constitutes notice from both LS Power and NYPA. The NYISO shall also provide a courtesy copy of all notices that are sent to the designated project manager to the NYPA contact listed below; however, only notice provided by the NYISO to the designated project manager shall constitute notice that is required or that may be sent under the terms of this Agreement. Any notice or request made to or by any Party regarding this Agreement shall be made to the Parties, as indicated below.

New York Independent System Operator, Inc.

Attn: Zachary G. Smith
Vice President, System and Resource Planning

NYISO Agreements --> Service Agreements --> Development Agreement Segment A, NYISO, LS Power, NYPA
10 Krey Boulevard
Rensselaer, NY 12144

SERVICE AGREEMENT NO. 2514

Phone: (518) 356-6000
Fax: (518) 356-6118

Developer Designated Project Manager

LS Power Grid New York Corporation I
Attn: Project Manager
16150 Main Circle Dr., Suite 310
Chesterfield, MO 63017
Phone: (636) 532-2200

Developer Billing and Payment Contact

Same as Developer Designated Project Manager.

NYPA Courtesy Contact

New York Power Authority
Attn: General Counsel Office
123 Main Street
White Plains, NY 10601
Phone: (914) 681-6200

15.2. Entire Agreement

Except as described below in this Section 15.2, this Agreement, including all Appendices attached hereto, constitutes the entire agreement between the Parties with reference to the subject matter hereof, and supersedes all prior and contemporaneous understandings of agreements, oral or written, between the Parties with respect to the subject matter of this Agreement. There are no other agreements, representations, warranties, or covenants that constitute any part of the consideration for, or any condition to, either Party's compliance with its obligation under this Agreement.

Notwithstanding the foregoing, this Agreement is in addition to, and does not supersede or limit the Developer's and NYISO's rights and responsibilities, under any interconnection agreement(s) entered into by and among the NYISO, Developer, and Connecting Transmission Owner(s) for the Transmission Project to interconnect to the New York State Transmission System, as such interconnection agreements may be amended, supplemented, or modified from time to time.

15.3. Cost Recovery

The Developer may recover the costs of the Transmission Project in accordance with the cost recovery requirements in the ISO Tariffs.

SERVICE AGREEMENT NO. 2514

15.4. Binding Effect

This Agreement, and the rights and obligations hereof, shall be binding upon and shall inure to the benefit of the successors and permitted assigns of the Parties hereto.

15.5. Force Majeure

A Party that is unable to carry out an obligation imposed on it by this Agreement due to Force Majeure shall notify the other Party in writing as soon as reasonably practicable after the occurrence of the Force Majeure event and no later than the timeframe set forth in Article 3.3.3(i) if the Force Majeure event will result in a potential delay for the Developer to meet a Critical Path Milestone. If the notifying Party is the Developer, it shall indicate in its notice whether the occurrence of a Force Majeure event has the potential to delay its meeting one or more Critical Path Milestones and/or completing the Transmission Project by the Required Project In-Service Date. If the Force Majeure will delay the Developer's ability to meet one or more Critical Path Milestones, the Developer shall request with its notice a change to the impacted milestones in accordance with the requirements in Section 3.3.4 and must satisfy the requirements in Section 3.3.4 to change any Critical Path Milestones. A Party shall not be responsible for any non-performance or considered in Breach or Default under this Agreement, for any failure to perform any obligation under this Agreement to the extent that such failure is due to Force Majeure and will not delay the Developer's ability to complete the Transmission Project by the Required Project In-Service Date. A Party shall be excused from whatever performance is affected only for the duration of the Force Majeure and while the Party exercises reasonable efforts to alleviate such situation. As soon as the nonperforming Party is able to resume performance of its obligations excused because of the occurrence of Force Majeure, such Party shall resume performance and give prompt notice thereof to the other Party. In the event that Developer will not be able to complete the Transmission Project by the Required Project In-Service Date because of the occurrence of Force Majeure, the NYISO may terminate this Agreement in accordance with Section 8.1 of this Agreement.

15.6. Disclaimer

Except as provided in this Agreement, the Parties make no other representations, warranties, covenants, guarantees, agreements or promises regarding the subject matter of this Agreement.

15.7. No NYISO Liability for Review or Approval of Developer Materials

No review or approval by the NYISO or its subcontractor(s) of any agreement, document, instrument, drawing, specifications, or design proposed by the Developer nor any inspection carried out by the NYISO or its subcontractor(s) pursuant to this Agreement shall relieve the Developer from any liability for any negligence in its preparation of such agreement, document, instrument, drawing, specification, or design, or its carrying out of such works; or for its failure to comply with the Applicable Laws and Regulations, Applicable Reliability Requirements, and Transmission Owner Technical Standards with respect thereto, nor shall the NYISO be liable to

the Developer or any other person by reason of its or its subcontractor's review or approval of an agreement, document, instrument, drawing, specification, or design or such inspection.

SERVICE AGREEMENT NO. 2514

15.8. Amendment

The Parties may by mutual agreement amend this Agreement, including the Appendices to this Agreement, by a written instrument duly executed by both of the Parties. If the Agreement was filed and accepted by FERC pursuant to Section 31.4.12.2 of Attachment Y of the OATT, the NYISO shall promptly file the amended Agreement for acceptance with FERC.

15.9. No Third Party Beneficiaries

With the exception of the indemnification rights of the NYISO's directors, officers, employees, trustees, and agents under Article 9.2, this Agreement is not intended to and does not create rights, remedies, or benefits of any character whatsoever in favor of any persons, corporations, associations, or entities other than the Parties, and the obligations herein assumed are solely for the use and benefit of the Parties, their successors in interest and their permitted assigns.

15.10. Waiver

The failure of a Party to this Agreement to insist, on any occasion, upon strict performance of any provision of this Agreement will not be considered a waiver of any obligation, right, or duty of, or imposed upon, such Party. Any waiver at any time by either Party of its rights with respect to this Agreement shall not be deemed a continuing waiver or a waiver with respect to any other failure to comply with any other obligation, right, or duty of this Agreement. Any waiver of this Agreement shall, if requested, be provided in writing.

15.11. Rules of Interpretation

This Agreement, unless a clear contrary intention appears, shall be construed and interpreted as follows: (1) the singular number includes the plural number and vice versa, except with respect to the definition of "Developer"; (2) reference to any person includes such person's successors and assigns but, in the case of a Party, only if such successors and assigns are permitted by this Agreement, and reference to a person in a particular capacity excludes such person in any other capacity or individually; (3) reference to any agreement (including this Agreement), document, instrument or tariff means such agreement, document, instrument, or tariff as amended or modified and in effect from time to time in accordance with the terms thereof and, if applicable, the terms hereof; (4) reference to any Applicable Laws and Regulations means such Applicable Laws and Regulations as amended, modified, codified, or reenacted, in whole or in part, and in effect from time to time, including, if applicable, rules and regulations promulgated thereunder; (5) unless expressly stated otherwise, reference to any Article, Section or Appendix means such Article of this Agreement, such Appendix to this Agreement, or such Section of this Agreement, as the case may be; (6) "hereunder", "hereof", "herein", "hereto" and words of similar import shall be deemed references to this Agreement as a whole and not to any particular Article or other provision hereof or thereof; (7) "including" (and with correlative meaning "include") means including without limiting the generality of any description preceding such term; and (8) relative to the determination of any period of time,

SERVICE AGREEMENT NO. 2514

“from” means “from and including”, “to” means “to but excluding” and “through” means “through and including”.

15.12. Severability

Each provision of this Agreement shall be considered severable and if, for any reason, any provision is determined by a court or regulatory authority of competent jurisdiction to be invalid, void, or unenforceable, the remaining provisions of this Agreement shall continue in full force and effect and shall in no way be affected, impaired, or invalidated, and such invalid, void, or unenforceable provision should be replaced with valid and enforceable provision or provisions that otherwise give effect to the original intent of the invalid, void, or unenforceable provision.

15.13. Multiple Counterparts

This Agreement may be executed in two or more counterparts, each of which is deemed an original, but all constitute one and the same instrument.

15.14. No Partnership

This Agreement shall not be interpreted or construed to create an association, joint venture, agency relationship, or partnership between or among the NYISO and the Developer (either collectively or individually with LS Power or NYPA) or to impose any partnership obligation or partnership liability between or among the NYISO, LS Power, or NYPA. No Party shall have any right, power, or authority to enter into any agreement or undertaking for, or act on behalf of, or to act as or be an agent or representative of, or otherwise bind, any other Party.

15.15. Headings

The descriptive headings of the various Articles and Sections of this Agreement have been inserted for convenience of reference only and are of no significance in the interpretation or construction of this Agreement.

15.16. Governing Law

This Agreement shall be governed, as applicable, by: (i) the Federal Power Act, and (ii) the substantive law of the State of New York, without regard to any conflicts of laws provisions thereof (except to the extent applicable, Sections 5-1401 and 5-1402 of the New York General Obligations Law).

15.17. Jurisdiction and Venue

Any legal action or judicial proceeding regarding a dispute arising out of or relating to this Agreement or any performance by either Party pursuant thereto that: (i) is within the primary or exclusive jurisdiction of FERC shall be brought in the first instance at FERC, or (ii) is not within the primary or exclusive jurisdiction of FERC shall be brought in, and fully and finally resolved in, either, as applicable, the courts of the State of New York situated in Albany County,

NYISO Agreements --> Service Agreements --> Development Agreement Segment A, NYISO, LS Power, NYPA
New York or the United States District Court of the Northern District of New York situated in
Albany, New York.

SERVICE AGREEMENT NO. 2514

IN WITNESS WHEREFORE, the Parties have executed this Agreement in duplicate originals, each of which shall constitute an original Agreement between the Parties.

New York Independent System Operator, Inc.

By:

Title:

Date:

LS Power Grid New York Corporation I

By:

Title:

Date:

New York Power Authority

By:

Title:

Date:

SERVICE AGREEMENT NO. 2514

Appendix A

Project Description

1. Transmission Project Overview

The transmission project is the Segment A Double-Circuit Proposal (“Transmission Project”) that was submitted by the Developer and evaluated in the NYISO’s Public Policy Transmission Planning Process and selected by the NYISO Board of Directors on April 8, 2019 as the more efficient and cost-effective transmission solution to the Segment A of the AC Transmission Public Policy Transmission Needs identified by the New York State Public Service Commission in its December 17, 2015 Order in Case No. 12-T-0502. The Transmission Project will be located in the Mohawk Valley Region (Zone E) and Capital Region (Zone F) in the State of New York and is principally comprised of a new double-circuit 345 kV transmission line between the Edic 345 kV substation and the New Scotland 345 kV substation.

2. Components of the Transmission Project

The Transmission Project consists of the following components:

- Two (2) new 345 kV transmission circuits of approximately 67 miles from the existing Edic 345 kV substation to the new Princetown 345 kV substation;
- Two (2) new 345 kV single-circuit transmission lines of approximately 5 miles between the new Princetown substation and the new Gordon Road 345 kV substation, one of which will connect to the new Princetown substation and the other will loop in the Edic portion of the existing Edic to New Scotland #14 345 kV transmission line;
- One (1) new double-circuit 345 kV transmission line of approximately 20 miles between the new Princetown substation and the existing New Scotland substation;
- Rebuild approximately six (6) miles of the existing Edic to New Scotland #14 345 kV transmission line to accommodate the new double-circuit 345 kV transmission line from Princetown to New Scotland;
- A new Gordon Road 345/230/115 kV substation with one (1) 345 kV connection to the new Princetown substation, one (1) 345 kV connection to the existing Edic substation, two (2) new 345/115 kV transformers connecting to the existing Rotterdam 115 kV switchyard, and two (2) new 345/230 kV transformers connecting to the Transmission Project’s new Gordon Road to Rotterdam #30 and #31 230 kV transmission lines;¹

NYISO Agreements --> Service Agreements --> Development Agreement Segment A, NYISO, LS Power, NYPA

¹The 345/230 kV transformers will initially serve the Gordon Road to Rotterdam 230 kV lines. After National Grid's completion of the Network Upgrade Facilities at the Rotterdam 115 kV substation (as more fully discussed below), one 345/230 kV transformer will remain in-service and the second transformer will become a spare.

SERVICE AGREEMENT NO. 2514

- A new Princetown 345 kV substation with two (2) new 345 kV connections to the existing Edic substation, one (1) new 345 kV connection to the new Gordon Road substation, two (2) new 345 kV connections to the existing New Scotland substation, and one (1) 345 kV connection to the existing New Scotland substation via the partially rebuilt Edic to New Scotland #14 345 kV transmission line;
- Decommissioning² of the Rotterdam to New Scotland #13 115 kV transmission line;
- Decommissioning of the Porter to Rotterdam #30 and #31 230 kV transmission lines;
- Decommissioning work at the Rotterdam 230 kV substation;³ and
- Terminal upgrades at the Marcy and Edic 345 kV substations.

The Transmission Project also included upgrades and expansions to existing transmission facilities owned by Transmission Owners, which will be identified as Network Upgrade Facilities and handled in the Transmission Project Interconnection Agreement, as described below:

- Equipment replacements, removals, and/or additions at existing terminal facilities to interconnect the Transmission Project, which include, but are not limited to, the removal, addition, or replacement of circuit breakers, switches, metering equipment, and/or protective relaying modifications. The following substations that may be affected by such Network Upgrade Facilities include, but are not limited to:
 - Edic 345/115 kV substation,
 - New Scotland 345/115 kV substation,
 - Rotterdam 115 kV substation,⁴
 - Porter 230 kV substation, and
 - Eastover 230 kV substation.

3. Interconnection Facilities

Developer submitted an Interconnection Request for the Transmission Project to be studied in the NYISO's Transmission Interconnection Procedures under Attachment P to the NYISO's Open Access Transmission Tariff ("OATT"). The NYISO assigned the Transmission Project Queue No. 556. The interconnection and operation of the Transmission Project require

² For purposes of this Appendix A, "decommissioning" means performing the activities required to remove such facilities from service in accordance with Good Utility Practice and subsequent removal of the facilities, as necessary.

³ Decommissioning of the Rotterdam 230 kV substation will be consistent with the Network Upgrade Facilities detailed in the Transmission Project Interconnection Agreements, or any amendment thereof, and will be completed following National Grid's completion of the Network Upgrade Facilities at the Rotterdam 115 kV substation.

NYISO Agreements --> Service Agreements --> Development Agreement Segment A, NYISO, LS Power, NYPA

⁴ Network Upgrade Facilities at the Rotterdam 115 kV substation will be an ongoing effort by National Grid with an expected completion date of 2027 and dependent work continuing until early 2029.

SERVICE AGREEMENT NO. 2514

the construction of Network Upgrade Facilities, identified through the Transmission Interconnection Procedures. The identified facilities and associated responsibilities in designing, engineering, procuring, installing, constructing, testing, and commissioning are addressed in (i) the Transmission Project Interconnection Agreement among the LS Power,⁵ Niagara Mohawk Power Corporation d/b/a National Grid, and the NYISO, designated as Service Agreement No. 2612, dated as of April 2, 2021, and (ii) the Transmission Project Interconnection Agreement among NYPA, Niagara Mohawk Power Corporation d/b/a National Grid, and the NYISO, designated as Service Agreement No. 2611, dated as of April 29, 2021.

As set forth in Service Agreement No. 2612, certain Network Upgrade Facilities being constructed by National Grid are not expected to be completed until 2029. As a result, the Transmission Project and identified Network Upgrade Facilities, as fully described in the Service Agreement No. 2612, or any amendment thereof, will be configured in a manner that is intended to allow the major components of the Transmission Project to enter service as National Grid completes the final Network Upgrade Facilities at the Rotterdam 115 kV substation. The configuration with the interim Network Upgrade Facilities is depicted below:

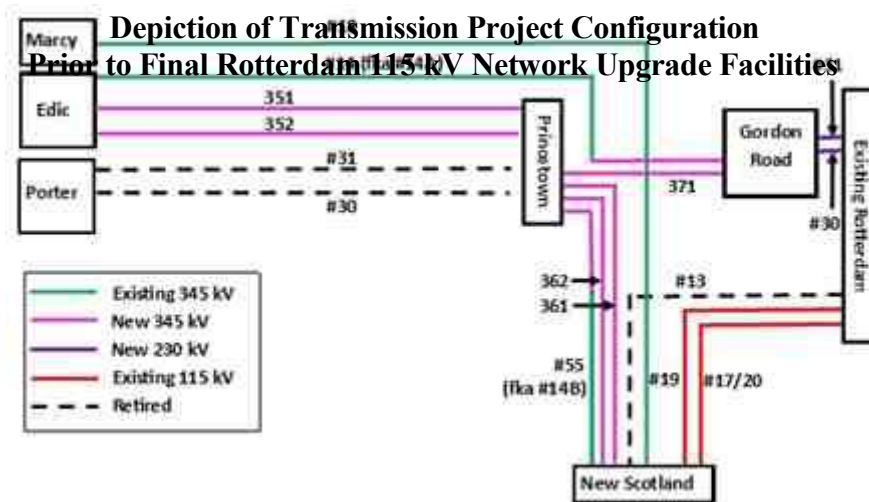

⁵ To the extent that there are no requirements in the OATT to the contrary, LS Power or NYPA may

NYISO Agreements --> Service Agreements --> Development Agreement Segment A, NYISO, LS Power, NYPA individually or jointly enter into applicable agreements for the purpose of meeting the Developer's obligations under this Agreement; provided, however, LS Power or NYPA individually entering into an agreement to satisfy the Developer's obligations shall not affect the obligations under Article 3.13 of the Agreement.

SERVICE AGREEMENT NO. 2514

Appendix B

Scope of Work

1. New Components of Transmission Project:

The Developer shall design, engineer, procure, install, construct, test, and commission the Transmission Project as described in Appendix A of this Agreement and pursuant to this Appendix B. Any required Network Upgrade Facilities, as described in Appendix A, shall be identified and finalized in the Transmission Interconnection Procedures and addressed in the Transmission Project Interconnection Agreement, or any amendment thereof, and/or associated engineering, procurement, and construction agreements among the Developer,⁶ the Connecting Transmission Owner(s) and/or Affected System Operator(s). Based on a preliminary design, the components of the Transmission Project will consist of the following major electrical and physical equipment:

(a) New Gordon Road 345 kV Substation with Breaker and Half Configuration

- Decommission⁷ work at the existing 230 kV substation;⁸
- Gas-Insulated Substation comprising of nine (9) 345 kV, 4000A, circuit breakers and associated disconnect switches, instrument transformers, station service supplies, and local control units;
- Two (2) 345/115 kV, low impedance transformers rated at least 650 MVA that, in the final configuration, connect the existing Rotterdam 115 kV switchyard to the new Gordon Road 345 kV substation;
- Two (2) 345/230 kV transformers rated at least 480 MVA, initially connecting to the Transmission Project's new Gordon Road to Rotterdam #30 and #31 230 kV transmission lines;⁹
- One (1) dead-tank gas circuit breaker, 242 kV, 3000A continuous;

⁶To the extent that there are no requirements in the OATT to the contrary, LS Power or NYPA may individually or jointly enter into applicable agreements for the purpose of meeting the Developer's obligations under this Agreement; provided, however, LS Power or NYPA individually entering into an agreement to satisfy the Developer's obligations shall not affect the obligations under Article 3.13 of the Agreement.

⁷For purposes of this Appendix B, "decommission" means perform the activities required to remove such facilities from service in accordance with Good Utility Practice and subsequent removal of the facilities, as necessary.

⁸Decommissioning of the Rotterdam 230 kV substation will be consistent with the Network Upgrade Facilities detailed in the Transmission Project Interconnection Agreements, or any amendment thereof, and will be completed following National Grid's completion of the Network Upgrade Facilities at the Rotterdam 115 kV substation.

⁹The 345/230 kV transformers will initially serve the Gordon Road to Rotterdam 230 kV lines. After

NYISO Agreements --> Service Agreements --> Development Agreement Segment A, NYISO, LS Power, NYPA
National Grid's completion of the Network Upgrade Facilities at the Rotterdam 115 kV substation, one 345/230 kV transformer will remain in-service and the second transformer will become a spare.

SERVICE AGREEMENT NO. 2514

- Three (3) air insulated disconnect switches with motor operators, 242 kV, 3000A continuous;
- Two (2) air insulated disconnect switches with motor operators, 123 kV, 5000A continuous;
- Eighteen (18) 345 kV station class surge arresters;
- Six (6) 230 kV station class surge arresters;
- Six (6) 115 kV station class surge arresters;
- Three (3) CCVT's, 242 kV, 1200/2000:1;
- Six (6) CCVT's, 115 kV, 600/1000:1;
- Station service voltage transformer (SSVT) and one (1) additional alternative station service supply;
- Metering Instrument Transformers (VT/CTs) in accordance with New York Public Service Commission ("NYPSC") requirements, if applicable (metering requirements to be finalized in Facilities study);
- Structures, foundations, insulators, grounding, trench, conduit, control cable, and physical security;
- Site development and grading; and
- One (1) control house (size to be finalized in detailed engineering) including: approximately twenty nine (29) panels for Line and Transformer Protection, Control, Communications, Metering, Remote Terminal Unit (RTU), SCADA, Digital Fault Recorder (DFI), Human Machine Interface (HMI), Sequence of Events Recorder (SOER), Phasor Measurement Unit (PMU); two (2) battery banks; DC panelboards; AC panelboards; Automatic Transfer Switch (ATS). The actual number of protection panels will be determined through detailed engineering in conjunction with the Connecting Transmission Owner(s) and as approved in the NPCC approval process (if applicable).

(b) New Princetown Gas Insulated Substation (GIS) with Breaker and Half Configuration

- GIS comprised of nine (9) 345 kV, 4000A, circuit breakers and associated disconnect switches, instrument transformers, station service supplies, and local control units;
- Six (6) disconnect switches with motor operator, 362 kV, 4000 A continuous;

SERVICE AGREEMENT NO. 2514

- Metering Instrument Transformers (VT/CTs) in accordance with NYPSC requirements, if applicable (metering requirements to be finalized in Facilities Study);
- Eighteen (18) 345 kV station class surge arresters;
- Structures, foundations, insulators, grounding, trench, conduit, control cable and physical security;
- Site development and grading; and
- One (1) control house (size to be finalized in detailed engineering) including: approximately thirty one (31) panels for Line and Transformer Protection, Control, Communications, Metering, Remote Terminal Unit (RTU), SCADA, Digital Fault Recorder (DFI), Human Machine Interface (HMI), Sequence of Events Recorder (SOER), Phasor Measurement Unit (PMU); two (2) battery banks; DC panelboards; AC panelboards; Automatic Transfer Switch (ATS). The actual number of protection panels will be determined through detailed engineering in conjunction with the Connecting Transmission Owner(s) and as approved in the NPCC approval process (if applicable).

(c) New 345 kV transmission line from Edic to Princetown

- Beginning at the Porter Substation and extending for approximately 12 miles, remove the existing conductor, shield wire, and associated hardware for the existing Porter to Rotterdam #30 and #31 230 kV transmission lines from the existing double-circuit steel monopole structures, leaving said structures in place;
- Beginning approximately 13 miles from the Edic substation and ending at the new Princetown substation, extending for approximately 55 miles, remove the existing Porter to Rotterdam #30 and #31 230 kV transmission lines, including the existing structures;
- Construct new single- and double-circuit steel structures for two (2) 345 kV transmission circuits, and remove existing structures as necessary, in the existing right-of-way between Edic substation and the existing double-circuit structures near Porter substation;
- Construct new single- and double-circuit steel structures for two (2) 345 kV transmission circuits in the existing Porter to Rotterdam 230 kV right-of-way beginning approximately 13 miles from the Edic Substation and ending at the new Princetown substation;
- Install double bundled, 954 kcmil 54/7 “Cardinal” Aluminum Conductor Steel Supported (ACSS) conductor;

SERVICE AGREEMENT NO. 2514

- Install shield wires, which will include at least one (1) optical ground wire (OPGW) with at least 36 fibers.

(d) Two (2) new single-circuit 345 kV transmission lines from Princetown to Rotterdam/Gordon Road

- Beginning at Princetown substation and ending at the Gordon Road substation, extending for approximately 5 miles, remove the existing Porter to Rotterdam #30 and #31 230 kV transmission lines, including the existing structures;
- Construct new steel structures for two (2) 345 kV single-circuit transmission lines in the existing Porter to Rotterdam 230 kV right-of-way, one of which will connect to Princetown substation and the other will loop in the Edic portion of the existing Edic to New Scotland # 14 345 kV transmission line;
- Install double bundled, 954 kcmil 54/7 “Cardinal” ACSS conductor;
- Install shield wires, which will include at least one (1) optical ground wire (OPGW) with at least 36 fibers.

(e) New double-circuit 345 kV transmission line from Princetown to New Scotland

- Decommission the Rotterdam to New Scotland #13 115 kV transmission line;
- Construct new steel structures for a 345 kV double-circuit transmission line in the existing Princetown to New Scotland right-of-way, extending for approximately 20 miles;
- Install double bundled, 954 kcmil 54/7 “Cardinal” ACSS conductor;
- Install shield wires, which will include at least one (1) optical ground wire (OPGW) with at least 36 fibers.

(f) Rebuild approximately six (6) miles of the existing Edic to New Scotland #14 345 kV single-circuit transmission line

- Beginning at the new Princetown substation and extending for approximately 6 miles southward, remove the existing Edic to New Scotland #14 345 kV transmission line, including the existing structures;
- Construct new steel structures for a 345 kV single-circuit transmission line in the existing Princetown to New Scotland right-of-way, extending for approximately 6 miles with the southern end connecting to the existing Edic to New Scotland #14 345 kV transmission line and with the northern end connecting to the Princetown substation;

NYISO Agreements --> Service Agreements --> Development Agreement Segment A, NYISO, LS Power, NYPA

- Install double bundled, 795 kcmil 26/7 “Drake” aluminum conductor steel reinforced (ACSR) conductor; and

SERVICE AGREEMENT NO. 2514

- Install steel shield wire or an OPGW with at least 36 fibers.

(g) Terminal equipment replacement at Marcy 345 kV and Edic 345 kV Substations

- Replace terminal equipment necessary to allow a rating of at least 1670/1792/2075 on the Marcy to New Scotland 345 kV transmission line; and
- Replace terminal equipment necessary to allow a rating of at least 1882/2079/2384 on the Marcy to Edic 345 kV transmission line.

The Developer will coordinate the work and necessary outages with National Grid and Affected System Operators.

2. Permitting - Licensing, Environmental, and Regulatory Approvals

In accordance with Section 3.9 of this Agreement, the Developer shall be responsible for applying for and obtaining all necessary licensing, environmental, and regulatory approvals for the Transmission Project. Such approvals may include the following:

- (a) New York State Public Service Law Article VII Certificate of Environmental Compatibility and Public Need (“CECPN”);
- (b) Certificate of Public Convenience and Necessity issued pursuant to Section 68 of the New York State Public Service Law;
- (c) State Pollutant Discharge Elimination System (“SPDES”) General Permit from the New York State Department of Environmental Conservation (“NYSDEC”) for Stormwater Discharge during Construction Activities (GP-0-15-002);
- (d) Utility Work Permit from the New York State Department of Transportation (“NYSDOT”) (for highway crossings);
- (e) Work Permit from New York State Thruway Authority (“NYSTA”) (for crossing of New York State Thruway I-90), and utility crossings as needed;
- (f) Environmental Management and Construction Plan (“EM&CP”) from the NYPSC following issuance of the Article VII Certificate;
- (g) Section 401 Water Quality Certification from the NYPSC;
- (h) Section 10/404 permits from the U.S. Army Corps of Engineers (“USACE”);
- (i) Cultural Resources Information System determination form New York State Historic Preservation Office (“NYSHPO”); and

(j) Endangered Species Act Section 7 (“ESA”), Migratory Bird Treaty Act and Bald and Golden Eagle Protection Act consultation and Special Use Permit, if applicable, from United States Fish and Wildlife Service (“USFWS”).

SERVICE AGREEMENT NO. 2514

3. Site Control / Rights of Way Acquisition

The Developer is responsible for obtaining the necessary site control and/or rights of way (“ROWs”) for the construction of the Transmission Project in accordance with the milestones set forth in Appendix C of this Agreement.

4. Financing

The Developer is responsible for obtaining the necessary financing for the design, engineering, procurement, installation, construction, testing, commissioning, and operation of the Transmission Project in accordance with the milestone set forth in Appendix C of this Agreement.

5. Engineering and Design

The Developer is responsible for preparing the engineering design work. All engineering design work must comply with the Applicable Reliability Standards, in addition to all relevant guidelines and design standards, including, but not limited to:

- ANSI C2-2017 National Electrical Safety Code
- ASCE 48 Design of Steel Transmission Pole Structures
- IEEE Std. 524 Guide to the Installation of Overhead Transmission Line Conductors
- IEEE Std. 691 Guide for Transmission Structure Foundation Design and Testing
- NYPP Tie-Line Ratings Task Force 1995 Report
- ASCE Manual of Practice 113 Substation Structure Design Guide
- IEEE Std. 80 Guide for Safety in AC Substation Grounding
- ANSI C37, Standards Series for substations and circuit breakers
- ANSI C57, Standards Series for power and Instrument Transformers
- IEEE and ANSI standards for transmission lines and substations as applicable

6. Estimated Cost

The cost estimate (2018 U.S. dollars) for the Transmission Project is \$750 million, including a 30% contingency, consistent with the independent cost estimate used by the NYISO in its evaluation and selection and as documented in the AC Transmission Public Policy Transmission Planning Report, dated April 8, 2019.

SERVICE AGREEMENT NO. 2514

7. Other Requirements

This Agreement was executed prior to the completion of the Facilities Study for the Transmission Project in the Transmission Interconnection Procedures under Attachment P, the execution of a Transmission Project Interconnection Agreement for the Transmission Project, and the receipt of all necessary regulatory approvals. As a result, the construction, interconnection, and operation of the Transmission Project may require the construction of facilities and/or the assignment of responsibilities that differ from the preliminary design and assignment of responsibilities identified in this Appendix B. If the facilities identified through the Transmission Interconnection Procedures or the responsibilities associated with designing, engineering, procuring, installing, constructing, testing, and commissioning the identified facilities materially differ from this Appendix B, the Parties shall amend this Agreement as necessary.

8. Local Control Center

LS Power will establish transmission operations facilities, including primary and backup control centers, with full operational functionality and situational awareness tools within the State of New York. LS Power will design, construct, and operate these transmission operations facilities in accordance with applicable NYISO, NPCC, and NERC Reliability Standards and requirements.

SERVICE AGREEMENT NO. 2514

Appendix C

Development Schedule

The Developer shall demonstrate to the NYISO that it timely meets the following Critical Path Milestones and Advisory Milestones contained herein and that such milestones remain in good standing. This Agreement is being executed prior to the completion of the Facilities Study under the Transmission Interconnection Procedures, the execution of a Transmission Project Interconnection Agreement, and the receipt of regulatory approvals, which could affect the milestones set forth herein. In the event that the completion of the Transmission Interconnection Procedures, the execution of a Transmission Project Interconnection Agreement, or receipt of regulatory approvals materially affect a milestone set forth in this Appendix C, the Parties shall review the milestones and the Developer shall seek to amend the milestone(s), as necessary, pursuant to the terms of this Agreement. For purposes of these milestones, a milestone that is required to be completed by the Developer may be completed by either LS Power or NYPA, as applicable; provided, however, completion of a milestone by either LS Power or NYPA shall not affect the obligations under Article 3.13 of the Agreement.

1	Commence public outreach plan	Developer	Advisory	N/A	Complete
2	Commence Preliminary Engineering and Design for the new Gordon Road 345 kV Substation, the new Princetown Substation, and the new 345 kV circuits	Developer	Advisory	N/A	Complete
3	Commence land acquisition activities	Developer	Advisory	N/A	Complete
4	Execute TIP Facilities Study Agreement for Q#556	Developer NYISO Connecting Transmission Owner(s) ¹	Advisory	N/A	Complete
5	Complete negotiation of site access for field studies related to the Transmission Project	Developer	Advisory	N/A	Complete

¹The Connecting Transmission Owner is National Grid, whom was identified in the System Impact Study for Q#556, and is listed in the milestones solely for informational purposes. Additional Connecting Transmission Owners may be identified in the Facilities Study for Q#556 under Attachment P to the ISO OATT.

[Redacted Header]					

SERVICE AGREEMENT NO. 2514

6	File Article VII CECPN Application	Developer	Critical	N/A	Complete
7	Article VII CECPN Application deemed complete	NYPSC	Critical	N/A	Complete
8	Submit Proof of Insurance pursuant to Article 6	Developer	Advisory	Within ten (10) days of the execution of this Agreement or the date on which the Agreement is filed with FERC	Complete
9	Provide financing plan for the Transmission Project to the NYISO ²	Developer	Advisory	2/15/2020	Complete
10	File NYISO Quarterly Report ³	Developer	Advisory	3/15/2020	Complete
11	File Section 68 Application	Developer	Advisory	5/15/2020	Complete
12	Complete TIP Facilities Study for Q#556	NYISO Connecting Transmission Owner(s)	Advisory	5/31/2020	Complete
13	File NYISO Quarterly Report	Developer	Advisory	6/15/2020	Complete
14	Submit transmission outage plan for 2021	Developer	Advisory	8/1/2020	Complete
15	File NYISO Quarterly Report	Developer	Advisory	9/15/2020	Complete
16	Execution of Transmission Project Interconnection Agreement(s)	Developer NYISO Connecting Transmission Owner(s)	Advisory	12/1/2020	Complete

² For purposes of this milestone, the Developer shall provide a plan to ensure access to sufficient capital reasonably necessary to complete the Transmission Project.

SERVICE AGREEMENT NO. 2514

17	Approval of transmission outage plan for 2021	NYISO Connecting Transmission Owner(s)	Advisory	12/1/2020	Complete
18	File NYISO Quarterly Report	Developer	Advisory	12/15/2020	Complete
19	File NYISO Quarterly Report	Developer	Advisory	3/15/2021	Complete
20	File NYISO Quarterly Report	Developer	Advisory	6/15/2021	Complete
21	Submit transmission outage plan for 2022	Developer	Advisory	8/1/2021	Complete
22	Notification to the NYISO the plans for operation of the facility ⁴	Developer	Advisory	8/23/2021	Complete
23	File NYISO Quarterly Report	Developer	Advisory	9/15/2021	Complete
24	Notification to the NYISO of selected general construction contractor(s) for the major transmission line segment ⁵ that will begin construction first and that applicable contracting agreement(s) for that portion are fully executed	Developer	Advisory	11/15/2021	Complete
25	Article VII CECPN and Section 68 approvals	NYPSC	Critical	12/1/2021	Complete
26	Approval of transmission outage plan for 2022	NYISO Connecting Transmission Owner(s)	Advisory	12/1/2021	Complete

⁴ For purposes of the milestones set forth in this Appendix C, the notification shall inform the NYISO as to the Developer’s plans for what entity will be operating the facilities, the location where such operations will occur, and any additional work to the local control center that may be necessary in order to accommodate the operation of project, such as, but not limited to, ensuring sufficient reliable distribution feed(s), reliable voice and data communication feed(s), computer system requirements, and backup generator/uninterruptible power supply (“UPS”) capacity.

⁵ For purposes of the milestones set forth in this Appendix C, the construction of the transmission line for the Transmission Project will be segmented, and a “major transmission line segment” shall refer to (i) the

SERVICE AGREEMENT NO. 2514

27	Status update meeting with NYISO to discuss Article VII CECPN and Section 68 approval	Developer NYISO	Advisory	12/15/2021	Complete
28	File NYISO Quarterly Report	Developer	Advisory	12/15/2021	Complete
29	Intentionally Omitted				
30	Engineering design finalized for the major transmission line segment that will begin construction first ⁶	Developer	Critical	1/15/2022	Complete
31	Submit proposed protection for the BPS element to NPCC for approval (if applicable)	Developer	Advisory	2/1/2022	Complete
32	File EM&CP ⁷ for the major transmission line segment that will begin construction first	Developer	Critical	2/1/2022	Complete
33	File NYISO Quarterly Report	Developer	Advisory	3/15/2022	Complete
34	Complete all environmental field studies necessary for submission of the EM&CP applications for the new Gordon Road 345 kV Substation, the new Princetown Substation, and remaining components of the Transmission Project not covered by Milestone No. 24	Developer	Advisory	4/1/2022	Complete

⁶ For purposes of the milestones set forth in this Appendix C, “engineering design finalized” shall mean that engineering design is sufficiently complete for drawings to be issued for the commencement of construction.

⁷ While there could be multiple, phased EM&CP approvals from the NYPSC, this Critical Path Milestone serves as the date on which the Developer must file an EM&CP application for the major transmission line segment

[Redacted]					
		4			

SERVICE AGREEMENT NO. 2514

35	Complete land and facility acquisition activities ⁸ for the new Gordon Road 345 kV Substation, the new Princetown Substation, and the new 345 kV transmission line circuits	Developer	Advisory	4/15/2022	Complete
36	Obtain NPCC approval of the protection for the BPS element (if applicable)	Developer	Advisory	5/1/2022	Complete
37	Apply to the U.S. Army Corps of Engineers for a Section 10 permit(s) for the Transmission Project (as necessary)	Developer	Advisory	6/1/2022	Complete
38	File NYISO Quarterly Report	Developer	Advisory	6/15/2022	Complete
39	NYPSC order approving EM&CP for the major transmission line segment that will begin construction first	NYPSC	Critical	8/1/2022	Complete
40	Complete procurement of major electrical equipment and materials ⁹ for the new Gordon Road 345 kV Substation, the new Princetown Substation, and remaining major transmission line segments not covered by Milestone No. 24	Developer	Critical	8/1/2022	Complete
41	Submit transmission outage plan for 2023	Developer	Advisory	8/1/2022	Complete

⁸ For purposes of this milestone, “completion of land and facility acquisition activities” shall mean that the Developer has obtained all necessary documentation and/or agreements demonstrating (i) ownership of, (ii) a leasehold interest in, or (iii) a right to develop, modify, or remove the sites and/or facilities for the purpose of constructing the Transmission Project.

⁹ For purposes of the milestones set forth in this Appendix C, “major electrical equipment and materials” shall include the gas insulated switchgear including the gas insulated disconnect switches and circuit breakers, the 345/230 kV and 345/115 kV transformers for the Gordon Road 345 kV Substation, and the 345 kV conductor and structures for the new transmission line circuits. Further, “complete procurement” of major electric equipment and materials shall mean that the Developer has a valid and effective purchase order, agreement, or commercially recognized instrument with a vendor for the design, manufacture, and/or delivery of such equipment and materials,

NYISO Agreements --> Service Agreements --> Development Agreement Segment A, NYISO, LS Power, NYPA and the Developer has paid in full or made all applicable deposits for vendor to begin designing, manufacturing, and/or shipping such equipment and materials.

[Redacted Header]					

SERVICE AGREEMENT NO. 2514

42	Demonstrate adequate financing for the Transmission Project to the NYISO ¹⁰	Developer	Critical	9/1/2022	Complete
43	Construction mobilization for the Transmission Project ¹¹	Developer	Critical	9/1/2022	Complete
44	Commence substantial site work ¹² for the major transmission line segment that will begin construction first in accordance with the applicable EM&CP	Developer	Advisory	9/15/2022	Complete
45	File NYISO Quarterly Report	Developer	Advisory	9/15/2022	Complete
46	Provide notice to the NYISO confirming that all major electrical equipment and materials for the major transmission line segment that will begin construction first are available ¹³	Developer	Critical	10/1/2022	Complete
47	Commence installation of the new transmission line structures for the major transmission line segment that will begin construction first ¹⁴	Developer	Advisory	10/1/2022	Complete
48	Engineering design finalized for the remaining components of the Transmission Project not covered by Milestone No. 30	Developer	Critical	11/15/2022	Complete

¹⁰ For purposes of this milestone, the Developer shall demonstrate that it has access to sufficient capital reasonably necessary to complete the Transmission Project.

¹¹ For purposes of this milestone, “construction mobilization” means activation of the contractor’s physical and workforce resources to the construction site of any portion of the Transmission Project.

¹² For purposes of this milestone, “substantial site work” shall mean civil site construction, such as tree cutting, site clearing and grading, construction of ingress and egress routes, or excavation of foundations associated with any part of the Transmission Project in accordance with the approved EM&CP.

¹³ For purposes of the milestones set forth in this Appendix C, major electrical equipment and materials shall be “available” if they are (i) located on the appropriate construction site or designated marshalling yard(s) in reasonable proximity to the site where it will be installed, (ii) located in the Developer’s warehouse or other inventory stocking location of the Developer, or (iii) on order from the vendor with a scheduled delivery date prior to the time scheduled for its use in the applicable transmission facility.

¹⁴ For purposes of this milestone, “installation of the new transmission line structures” shall mean

NYISO Agreements --> Service Agreements --> Development Agreement Segment A, NYISO, LS Power, NYPA
installation of foundations, installation of pole base sections, or assembly of structures for any segment of the new
345 kV transmission lines.

[Redacted Header]					

SERVICE AGREEMENT NO. 2514

49	Approval of transmission outage plan for 2023	NYISO National Grid	Advisory	12/1/2022	Complete
50	File NYISO Quarterly Report	Developer	Advisory	12/15/2022	Complete
51	Execution or filing of Operating Agreement between the NYISO and LS Power	Developer NYISO	Critical	12/31/2022	Complete
52	Notification to the NYISO of LS Power’s plan to comply with the NYPSC order related to divestiture ¹⁵	Developer	Advisory	12/31/2022	Complete
53	Commence conductoring of new 345 kV lines for the major transmission line segment that will begin construction first ¹⁶	Developer	Advisory	1/1/2023	Complete
54	Notification to the NYISO of selected general construction contractor(s) for the remaining components of the Transmission Project not covered by Milestone No. 24 and that applicable contracting agreement(s) for those portions are fully executed	Developer	Advisory	2/1/2023	Complete
55	Commence foundation installation for the new Gordon Road 345 kV Substation	Developer	Advisory	3/1/2023	Complete
56	File NYISO Quarterly Report	Developer	Advisory	3/15/2023	Complete

¹⁵ See PSC Case No. 17-E-0016, *Petition of TC Ravenswood, LLC, TC Ravenswood Service Corp. and Helix Generation for Expedited Approval of a Transfer and Financing Pursuant to Lightened Regulation, Order Approving Transfer Subject to Acceptance of Conditions and Making Other Findings* (April 19, 2017). For purposes of this milestone, if LS Power enters and files a contract for the sale of the Transmission Project, the Developer shall provide a plan for the completion of the Transmission Project, including, but not limited to, any plan or intent to potentially assign its rights and obligations pursuant to Article 10 of this Agreement and any potential delays to completion of the Transmission Project.

¹⁶ For purposes of this milestone, “commence conductoring” means setup of conductor pulling equipment and beginning the installation of conductor on any part of the new 345 kV transmission line for the Transmission

[Redacted]					
		7			

SERVICE AGREEMENT NO. 2514

57	NYPSC order approving the last required EM&CP for the Transmission Project ¹⁷	NYPSC	Critical	4/1/2023	Complete
58	Commence foundation installation for the new Princetown Substation	Developer	Advisory	6/1/2023	Complete
59	Provide notice to the NYISO confirming that all major electrical equipment and materials for the Transmission Project are available	Developer	Critical	6/15/2023	Complete
60	File NYISO Quarterly Report	Developer	Advisory	6/15/2023	Complete
60a	Completion of verification and testing of the local control center	LS Power	Critical	8/1/2023	Complete
61	Submit final energization plan to the NYISO and the Connecting Transmission Owner(s)	Developer	Critical	9/1/2023	Complete
62	Obtain NERC certification for operators, as applicable	Developer	Critical	9/1/2023	Complete
63	Completion of Network Upgrade Facilities (other than certain Network Upgrade Facilities identified in the Transmission Project Interconnection Agreement ¹⁸)	Connecting Transmission Owner(s)	Advisory	12/15/2023	
64	File NYISO Quarterly Report	Developer	Advisory	9/15/2023	Complete
65	NERC Certified Operators Complete NYISO's System Operator Training ("SOTS") (if applicable)	Developer	Critical	11/15/2023	Complete

¹⁷ For purposes of the milestone, the "last required EM&CP" refers to the last necessary EM&CP approval needed for the Transmission Project, and shall not include an EM&CP approval needed by a Connecting Transmission Owner or Affected Transmission Owner to construct Network Upgrade Facilities.

SERVICE AGREEMENT NO. 2514

66	Completion of the new Gordon Road 345 kV Substation, the new Princetown Substation, and all of the new 345 kV transmission line circuits ¹⁹	Developer	Critical	12/15/2023
67	Completion of the terminal work at Edic 345 kV and Marcy 345 kV substations to increase the line rating ²⁰	Developer National Grid	Advisory	12/15/2023
68	File NYISO Quarterly Report	Developer	Advisory	12/15/2023
69	Perform connections to the New York State Transmission System and complete verification and testing of the Transmission Project, in accordance with the final energization plan ²¹	Developer, Connecting Transmission Owner(s)	Advisory	12/29/2023
70	Transmission Project Energization and In-Service ²²	Developer	Critical	12/31/2023
71	Completion of all Network Upgrade Facilities at the Rotterdam Substations in accordance with the Transmission Project Interconnection Agreement	Connecting Transmission Owner(s)	Advisory	2/28/2029

¹⁹ For purposes of this milestone, “completion of the new Gordon Road 345 kV Substation, the new Princetown Substation, and the new 345 kV transmission line circuits” means completion of all work necessary for the facilities to be ready for testing but excludes the final construction work to connect such transmission facilities to the New York State Transmission System and testing activities.

²⁰ For purposes of this milestone, “completion of the terminal work at Edic 345 kV and Marcy 345 kV substations” mean completion of all work necessary for the facilities to be ready for testing but excludes the final construction work to connect such transmission facilities to the New York State Transmission System and testing activities.

²¹ This milestone does not include the completion of certain Network Upgrade Facilities at the Rotterdam Substations that are being constructed in accordance with the Transmission Project Interconnection Agreement, Service Agreement No. 2612, among the NYISO, the Developer, and National Grid, or any amendment thereof. This milestone shall be completed in accordance with the final energization plan but no later than two (2) calendar days prior to the energization of the Transmission Project (*i.e.*, Milestone No. 70).

²² This milestone does not include the completion of certain Network Upgrade Facilities at the Rotterdam and Eastover Substations that are being constructed in accordance with the Transmission Project Interconnection Agreement among the NYISO, the Developer, and National Grid. Upon completion of Milestone 70, the Developer

NYISO Agreements --> Service Agreements --> Development Agreement Segment A, NYISO, LS Power, NYPA
has a limited scope of work to accommodate the Network Upgrade Facilities that are being constructed by the
Connecting Transmission Owner, which includes, but not limited to, updating relay settings.

[Redacted Header]					

SERVICE AGREEMENT NO. 2514

72	Project Required In-Service Date ²³	Developer	Critical	2/28/2029
----	--	-----------	----------	-----------

²³ Upon completion of Milestone 70, Developer has a limited scope of work, for example, relay settings updates to accommodate the Network Upgrade Facilities.



--	--	--	--	--	--
