

Service Agreement No. 1852

AN

INTERCONNECTION AGREEMENT

BETWEEN

NIAGARA MOHAWK POWER CORPORATION d/b/a NATIONAL GRID

AND

GRIFFISS UTILITY SERVICES CORPORATION

EXECUTION COPY

Service Agreement No. 1852

ARTICLE I DEFINITIONS 1

ARTICLE II AGREEMENT TO INTERCONNECT DESCRIPTION OF INTERCONNECTION FACILITIES 7

ARTICLE III REPRESENTATIONS AND WARRANTIES OF PARTIES 9

ARTICLE IV INTERCONNECTION STUDY 10

ARTICLE V OPERATION, MAINTENANCE, AND MODIFICATION OF FACILITIES 14

ARTICLE VI POWER DELIVERIES 19

ARTICLE VII EMERGENCIES 20

ARTICLE VIII INSURANCE PROVISIONS 22

ARTICLE IX COMPLIANCE WITH LAWS 23

ARTICLE X COST PAYMENTS 25

ARTICLE XI NOTICES 28

ARTICLE XII TERM AND TERMINATION 29

ARTICLE XIII FORCE MAJEURE..... 31

ARTICLE XIV INDEMNIFICATION..... 31

ARTICLE XV RELATIONSHIP OF THE PARTIES..... 32

ARTICLE XVI THIRD PARTY BENEFICIARY/ASSIGNMENT..... 33

ARTICLE XVII APPROVAL 34

ARTICLE XVIII WAIVER 34

ARTICLE XIX AMENDMENT AND MODIFICATION..... 35

ARTICLE XX GOVERNING LAW 35

ARTICLE XXI DISPUTE RESOLUTION..... 36

ARTICLE XXII LIMITATION OF LIABILITY..... 36

ARTICLE XXIII CONFIDENTIALITY..... 37

ARTICLE XXIV SEVERABILITY 40

ARTICLE XXV HEADINGS..... 40

ARTICLE XXVI INFORMATION ACCESS AND AUDIT RIGHTS..... 40

ARTICLE XXVII. SUBCONTRACTORS 42

ARTICLE XXVIII COMPLIANCE WITH GOOD UTILITY PRACTICE..... 42

Service Agreement No. 1852

ARTICLE XXIX COUNTERPARTS42

ARTICLE XXX MISCELLANEOUS.....42

This INTERCONNECTION AGREEMENT (the “Agreement”) is made effective as of January 1, 2012, between Niagara Mohawk Power Corporation d/b/a National Grid (“National Grid”), a New York Corporation, and Griffiss Utility Services Corporation (“Customer”) a New York Corporation (collectively Customer and National Grid may be referred to as the “Parties” or, individually, as a “Party”).

WHEREAS, the Customer owns and operates an existing load serving electric system that provides electric service to land owners, tenants and other occupants within the Griffiss Business and Technology Park in Rome, New York (“Park”), which is connected to the National Grid Transmission System in New York State, and

WHEREAS, Customer currently receives electric service from National Grid pursuant to Service Agreement No. 920 (“SA 920”) under the New York Independent System Operator, Inc. (“NYISO”) Open Access Transmission Tariff which is set to expire after December 31, 2011, and the Parties have agreed to enter into this Agreement for the purpose of documenting certain terms and conditions governing the relationship between National Grid and Customer after the expiration of SA 920, and

WHEREAS, Customer and National Grid have agreed to enter into this Agreement for the purpose of documenting certain terms and conditions related to the interconnection of the systems and the manner by which National Grid and Customer will coordinate to ensure the ongoing reliability of the New York State Transmission System.

NOW THEREFORE, in consideration of the mutual representations, covenants and agreements set forth herein, the Parties to this Agreement agree as follows:

ARTICLE I DEFINITIONS

The following terms, when used herein with initial capitalization, shall have the meanings specified in this Article I. Terms used in this Agreement with initial capitalization that are not defined in this Article I shall have the meanings specified in Section 1.0 or Attachment S of the NYISO OATT.

“**Affiliate**” shall mean, with respect to a person or entity, any individual, corporation, partnership, firm, joint venture, association, joint-stock company, trust or unincorporated organization, directly or indirectly controlling, controlled by, or under common control with, such person or entity. The term “control” shall mean the possession, directly or indirectly, of the power to direct the management or policies of a person or an entity. A voting interest of ten percent or more shall create a rebuttable presumption of control.

“**Agreement**” shall mean this Interconnection Agreement between National Grid and Customer, including all exhibits hereto, as the same may be amended, supplemented, revised, altered, changed, or restated in accordance with its terms.

“Ancillary Services” shall mean those services that are necessary to support the transmission of Capacity and Energy from resources to Loads while maintaining reliable operation of the New York State Transmission System in accordance with Good Utility Practice.

“Applicable Laws and Regulations” shall mean all duly promulgated applicable federal, state and local laws, regulations, rules, ordinances, codes, decrees, judgments, directives, or judicial or administrative orders, permits and other duly authorized actions of any Governmental Authority, including but not limited to laws or regulations relating to pollution or protection of the environment or natural resources.

“Applicable Reliability Councils” shall mean the NERC, the NPCC and the NYSRC.

“Applicable Reliability Standards” shall mean the requirements and guidelines of the Applicable Reliability Councils, and the Transmission District to which the Customer System is directly interconnected, as those requirements and guidelines are amended and modified and in effect from time to time; provided that no Party shall waive its right to challenge the applicability or validity of any requirement or guideline as applied to it in the context of this Agreement.

“Breach” shall mean the failure of a Party to perform or observe any material term or condition of this Agreement.

“Bulletin No. 752” or **“ESB 752”** means that certain National Grid document designated as Electric System Bulletin No. 752 attached hereto as Exhibit B, as such Bulletin may be amended or superseded from time to time without amendment to this Agreement.

“Business Day” shall mean Monday through Friday, excluding federal holidays.

“Calendar Day” shall mean any day including Saturday, Sunday or a federal holiday.

“Capacity” shall mean Unforced Capacity as such term is defined in the NYISO Services Tariff.

“Confidential Information” means any plan, specification, pattern, procedure, design, device, list, concept, policy or compilation relating to the present or planned business of a Party which has not been released publicly by its authorized representatives and which has been designated as "Confidential" by the Party asserting a claim of confidentiality, whether such Confidential Information is conveyed orally, electronically, in writing, through inspection, or otherwise. Confidential Information as used herein also includes Confidential Information supplied by any Party to another Party prior to the execution of this Agreement, and such Confidential Information shall be considered in the same manner and be subject to the same treatment as the Confidential Information made available after the execution of this Agreement. Confidential Information shall also include

Confidential Information observed by any Party while visiting the premises of another Party.

“Control Area” shall mean an electric power system or combination of electric power systems to which a common automatic generation control scheme is applied in order to: (1) match, at all times, the power output of the Generators within the electric power system(s) and capacity and energy purchased from entities outside the electric power system(s), with the Load within the electric power system(s); (2) maintain scheduled interchange with other Control Areas, within the limits of Good Utility Practice; (3) maintain the frequency of the electric power system(s) within reasonable limits in accordance with Good Utility Practice; and (4) provide sufficient generating capacity to maintain Operating Reserves in accordance with Good Utility Practice. A Control Area must be certified by the NPCC.

“Customer” shall mean Griffiss Utility Services Corporation and its successors and permitted assigns.

“Customer Interconnection Facilities” shall mean facilities owned by the Customer that are necessary to effect the transfer of Electricity from the National Grid Transmission System to Customer, as such facilities are identified in more particularity in Exhibit A to this Agreement.

“Customer System” shall mean the interconnected group of electric transmission and distribution facilities that are owned by the Customer.

“Effective Date” shall mean the date on which this Agreement becomes effective upon execution by the Parties.

“Electricity” shall mean Capacity as measured in MW or kW, Energy as measured in MWh or kWh, and/or Ancillary Services.

“Emergency Condition” shall mean a condition or situation which is deemed imminently likely to (i) endanger life, property, or public health; or (ii) adversely affect or impair the reliability of the New York State Transmission System, the Customer System, Generators, or the electrical or transmission systems of others to which National Grid's electrical systems are directly or indirectly connected.

“Emergency State” shall mean the condition or state that the New York State Power System is in when an abnormal condition occurs that requires automatic or immediate manual action to prevent or limit loss of the New York State Transmission System or Generators that could adversely affect the reliability of the New York State Power System.

“Federal Power Act” shall mean the Federal Power Act, as amended, 16

U.S.C. §§ 791a et seq. (“FPA”).

“**FERC**” shall mean the United States of America's Federal Energy Regulatory Commission or any successor organization.

“**Force Majeure**” shall mean any act of God, labor disturbance, act of the public enemy, war, insurrection, riot, fire, storm or flood, explosion, breakage or accident to machinery or equipment, any order, regulation or restriction imposed by governmental, military or lawfully established civilian authorities, or any other cause beyond a Party's control. A Force Majeure event does not include acts of negligence or intentional wrongdoing by the Party claiming Force Majeure.

“**Generator**” shall mean a device for the production of electricity interconnected within the Customer's System exporting energy to the Customer System and/or the National Grid Transmission System and/or New York State Transmission System. The device shall be capable of supplying Energy, Capacity, and/or Ancillary Services (each as defined by the NYISO) that is accessible to the New York Control Area .

“**Good Utility Practice**” means any of the practices, methods and acts engaged in or approved by a significant portion of the electric utility industry during the relevant time period, or any of the practices, methods and acts which, in the exercise of reasonable judgment in light of the facts known at the time the decision was made, could have been expected to accomplish the desired result at a reasonable cost consistent with good business practices, reliability, safety and expedition. Good Utility Practice is not intended to be limited to the optimum practice, method, or act, to the exclusion of all others, but rather to be acceptable practices, methods, or acts generally accepted in the region in which Customer is located. Good Utility Practice shall include, but not be limited to, NERC (defined below) criteria, rules, guidelines and standards, NPCC (defined below) criteria, rules, guidelines and standards, NYSRC (defined below) criteria, rules, guidelines and standards, and NYISO (defined below) criteria, rules, guidelines and standards, where applicable, as they may be amended from time to time including the rules, guidelines and criteria of any successor organization to the foregoing entities.

“**Governmental Authority**” shall mean any federal, state, local or other governmental regulatory or administrative agency, court, commission, department, board, or other governmental subdivision, legislature, rulemaking board, tribunal, or other governmental authority having jurisdiction over any of the Parties, their respective facilities, or the respective services they provide, and exercising or entitled to exercise any administrative, executive, police, or taxing authority or power; provided, however, that for purposes of this Agreement, such term does not include Customer, National Grid, NYISO, or any Affiliate thereof.

“**Hazardous Substance(s)**” shall mean those substances, materials, products or wastes which are classified as hazardous or toxic under any applicable federal, state or local law,

or any regulations promulgated thereunder, effective as of the date of execution of this Agreement, and the presence of which requires remediation, removal or cleanup under this Agreement.

“Interconnection Facilities” shall include all those National Grid and Customer facilities and National Grid Properties or Customer properties necessary to effect the transfer of Electricity from the National Grid Transmission System to Customer, as such facilities are identified in more particularity in Exhibit A to this Agreement, and shall include any Modifications, replacements or upgrades made to the Interconnection Facilities.

“Interconnection Point(s)” shall mean the points at which the Interconnection Facilities are connected to the National Grid Transmission System as indicated on Exhibit A.

“Interconnection Study” shall mean the necessary studies performed by National Grid for interconnection or Modification of an interconnection of the Customer to the National Grid Transmission System. National Grid shall perform those studies that, in the judgment of National Grid, are necessary to determine (a) an appropriate Interconnection Point and delivery point, (b) conceptual equipment and the facilities necessary and desirable for the construction and operation of new or additional or modified facilities, (c) the interconnection voltage and operational constraints, (d) the estimated costs of facilities and/or the costs for National Grid's design, review, assistance and inspection of facilities to be designed and constructed by Customer, (e) the estimated costs of any new reinforcements to or additions of new facilities to the National Grid Transmission System required or recommended to be made in order for National Grid to interconnect with Customer in accordance with NYISO Tariff rules and regulations. Interconnection Study shall include the Interconnection Feasibility Study and the Interconnection System Reliability Impact Study.

“Load Serving Entity (LSE)” shall mean an entity, including a municipal electric system and an electric cooperative, authorized or required by law, regulatory authorization, agreement, or contractual obligation to supply Energy, Capacity, and/or Ancillary Services to retail customers located within the NYCA, including an entity that takes service directly from the NYISO to supply its own load in the NYCA

“Loss” shall mean any and all losses relating to injury to or death of any person or damage to property, demand, suits, recoveries, costs and expenses, court costs, attorney fees, and all other obligations by or to third parties, arising out of or resulting from the Indemnified Party's performance or non-performance of its obligations under this Agreement on behalf of the indemnifying Party, except in cases of gross negligence or intentional wrongdoing by the Indemnified Party.

“Metering Authority” shall mean an entity designated by the NYISO that is responsible for a NYISO electric revenue metering system for its calibration, maintenance, operation, and reporting of metered data.

“Metering Equipment” shall mean all metering equipment installed or to be installed at the Interconnection Facilities by National Grid or other Metering Authority pursuant to this Agreement at the metering points, including but not limited to instrument transformers, MWh-meters, data acquisition equipment, transducers, remote terminal unit, communications equipment, phone lines, and fiber optics.

“Modification” means any new construction, new facilities, additions, reinforcements, alterations, improvements, appurtenances, replacements or upgrades made to the Interconnection Facilities, National Grid Transmission System or Customer System after the Effective Date of this Agreement that has a material impact on the National Grid Transmission System or Customer System. "Modification" as it applies to the Interconnection Facilities or National Grid Transmission System shall also include Modifications which are required to support the operations of Customer, including those required by: (i) changes in the operations of Customer after the Effective Date as hereinafter defined, or (ii) changes in the technology employed at Customer’s Interconnection Facilities after the Effective Date.

“National Grid” shall mean Niagara Mohawk Power Corporation d/b/a National Grid and its successors and permitted assigns.

“National Grid Interconnection Facilities” shall mean facilities owned by National Grid that are necessary to effect the transfer of Electricity from the National Grid Transmission System to Customer, as such facilities are identified in more particularity in Exhibit A to this Agreement.

“National Grid Properties” shall mean those parcels of and/or interest in real property that National Grid uses for its Transmission System.

“National Grid Transmission System” means the properties, structures, facilities, equipment, devices, and apparatus wholly or partly owned or leased by, or under contract to, or under the control of National Grid or its Affiliates, necessary for the provision of services under the NYISO OATT and/or National Grid’s Retail Tariff .

“NERC” shall mean the North American Electric Reliability Corporation or any successor organization.

“New York Control Area” or “NYCA” shall have the same meaning as in the Independent System Operator Agreement establishing the NYISO.

“New York State Transmission System” shall mean the entire New York State electric transmission system, which includes (i) the Transmission Facilities under ISO Operational Control; (ii) the Transmission Facilities Requiring ISO Notification; and (iii) all remaining transmission facilities within the New York Control Area.

“NPCC” shall mean the Northeast Power Coordinating Council, Inc. or any successor organization.

“**NYISO OATT**” shall mean the FERC-approved Open Access Transmission Tariff for the NYISO, and as it may be amended or supplemented from time to time, or any successor tariff thereto.

“**NYISO Services Tariff**” shall mean the NYISO Market Administration and Control Area Services Tariff, as filed with the Commission, and as amended or supplemented from time to time, or any successor tariff thereto.

“**NYISO Tariffs**” shall mean the NYISO OATT and the NYISO Services Tariff and any successors thereto.

“**NYPA**” shall mean the Power Authority of the State of New York or any successor thereto.

“**NYPSC**” shall mean the New York Public Service Commission or any successor thereto.

“**NYSRC**” shall mean the New York State Reliability Council, L.L.C. or any successor organization.

“**Reasonable Efforts**” shall mean, with respect to an action required to be attempted or taken by a Party under this Agreement, efforts that are timely and consistent with Good Utility Practice and are otherwise substantially equivalent to those a Party would use to protect its own interests.

“**Retail Tariff**” means Niagara Mohawk's Retail Tariff, New York Public Service Commission ("NYPSC") No. 220 — Electricity as approved by the NYPSC and all subsequent revisions, as it may be amended from time to time.

“**Transmission Owner**” shall mean a public utility of authority (or its designated agent) that owns facilities used for the transmission of Energy in interstate commerce and provides Transmission Service under the NYISO OATT.

“**Upgrades**” shall mean the upgrades and additions to National Grid's Transmission System identified in any Interconnection Study.

ARTICLE II
AGREEMENT TO INTERCONNECT
DESCRIPTION OF INTERCONNECTION FACILITIES

- 2.1 This agreement governs the terms and conditions under which the Customer System is interconnected with, and operates in parallel with, the National Grid Transmission System. The Customer System serves as an electric service provider only, and National Grid will own and operate the Interconnection Facilities between the Transmission System Interconnection Point and the change in ownership point with the Customer System as described in Exhibit A. This Agreement does not address any terms and conditions under which the Customer might act as a Transmission Owner or a Generator.

- 2.2 National Grid and Customer are interconnected by means of existing Interconnection Facilities as identified on Exhibit A to this Agreement. Customer and National Grid agree that the installation of the electrical equipment and the operation of the Interconnection Facilities must meet or exceed the standards of Good Utility Practice, all requirements of Bulletin No. 752, the Interconnection Study and the NYISO; provided, however, that in the event of a conflict between the requirements, rules and regulations of the NYISO and the requirements of Bulletin No. 752, the requirements, rules and regulations of the NYISO shall govern.
- 2.3 Customer shall use Good Utility Practice to own, operate, maintain and make available the Customer Interconnection Facilities and Customer System. National Grid shall use Good Utility Practice to own, operate, maintain and make available the National Grid Interconnection Facilities and National Grid Transmission System. National Grid does not, however, guarantee or warrant uninterrupted availability of the National Grid Interconnection Facilities and National Grid Transmission System. Any curtailment of deliveries over the National Grid Interconnection Facilities and National Grid Transmission System shall be governed by Good Utility Practice, the terms and conditions of the NYISO Tariffs, ESB 752, National Grid's standard practices and procedures.
- 2.4 National Grid reserves the right to operate disconnect switch(s) at the Interconnection Facilities with twenty four (24) hour notice to Customer for National Grid requested maintenance or in an Emergency Condition after giving Customer reasonable notice under the circumstances. National Grid shall exercise such right of disconnect (a) in accordance with Bulletin No. 752, (b) in a non-discriminatory manner, (c) in accordance with Good Utility Practice, and (d) in recognition of Section 7.4 of this Agreement.
- 2.5 If Customer relies on National Grid's protection equipment and practices for protection or if Customer relies on any other of National Grid's equipment for support of its operations, Customer agrees to release, indemnify, defend, and save harmless National Grid, its agents and employees, against any and all claims, judgments, cost, liability, damage, injury, penalties, judgments, fines (civil or criminal), or other costs arising from any damage or loss to Customer as a result of such reliance, whether the loss, damage or injury result to or be sustained by Customer or any other persons, firms or corporations.
- 2.6 This Agreement does not waive, alter or impair the rights or obligations of any Party under any other agreement between the Parties.
- 2.7 No Transmission Delivery Service. The execution of this Agreement does not constitute a request for, nor agreement to provide, any Transmission Service under the NYISO Tariffs, and does not convey any right to deliver electricity to any specific customer or Point of Delivery. If Customer wishes to obtain Transmission Service on the New York State Transmission System, then Customer must request such Transmission Service in accordance with the provisions of the NYISO Tariffs.
- 2.8 The execution of this Agreement does not constitute a request for, nor agreement to provide for the supply of Energy, any Ancillary Services or Capacity under the NYISO

Tariffs. If Customer wishes to supply Energy, Capacity or Ancillary Services, then Customer will make application to do so in accordance with the NYISO Tariffs.

**ARTICLE III
REPRESENTATIONS AND WARRANTIES OF PARTIES**

- 3.1 Customer is a not-for-profit corporation duly organized and validly existing under the laws of the State of New York. Customer is qualified to do business under the laws of the State of New York, is in good standing under the laws of the State of New York, has the power and authority to own its properties, to carry on its business as now being conducted, and to enter into this Agreement and the transactions contemplated herein and perform and carry out all covenants and obligations on its part to be performed under and pursuant to this Agreement, and is duly authorized to execute and deliver this Agreement and consummate the transactions contemplated herein.
- 3.2 National Grid is a corporation duly organized, validly existing and qualified to do business under the laws of the State of New York, is in good standing under its certificate of incorporation and the laws of the State of New York, has the corporate authority to own its properties, to carry on its business as now being conducted, and to enter into this Agreement and the transactions contemplated herein and perform and carry out all covenants and obligations on its part to be performed under and pursuant to this Agreement, and is duly authorized to execute and deliver this Agreement and consummate the transactions contemplated herein.
- 3.3 Customer and National Grid each represents that: (a) it is not prohibited from entering into this Agreement and discharging and performing all covenants and obligations on its part to be performed under and pursuant to this Agreement; (b) upon the acceptance of the terms of this Agreement by FERC, the execution and delivery of this Agreement, the consummation of the transactions contemplated herein including the fulfillment of and compliance with the provisions of this Agreement will not conflict with or constitute a breach of or a default under any of the terms, conditions or provisions of any law, rule or regulation, any order, judgment, writ, injunction, decree, determination, award or other instrument or legal requirement of any court or other agency of government, or any contractual limitation, corporate restriction or outstanding trust indenture, deed of trust, mortgage, loan agreement, lease, other evidence of indebtedness or any other agreement or instrument to which it is a party or by which it or any of its property is bound and will not result in a breach of or a default under any of the foregoing; and (c) unless this Agreement is materially modified by any court or appropriate regulatory authority having jurisdiction and/or subsequently terminated by the Parties in accordance with the terms and conditions provided herein, this Agreement shall be a legal, valid and binding obligation enforceable in accordance with its terms, except as limited by any subsequent order of any court or appropriate regulatory authority having jurisdiction, or by any applicable reorganization, insolvency, liquidation, readjustment of debt, moratorium, or other similar laws affecting the enforcement of rights of creditors generally as such laws may be applied in the event of a reorganization, insolvency, liquidation, readjustment of debt or other

similar proceeding of or moratorium applicable to the Party and by general principles of equity (regardless of whether such enforceability is considered in a proceeding in equity or at law).

ARTICLE IV INTERCONNECTION FACILITIES

4.1 Interconnection Facilities.

4.1.1 Exhibit A to this Agreement shall separately identify the Interconnection Facilities associated with the existing delivery point. The Parties acknowledge and agree that all Interconnection Facilities and Upgrades necessary to effect the transfer of Electricity from the National Grid Transmission System to Customer have already been constructed and that, as of the Effective Date, no Interconnection Study contemplates any further changes to Interconnection Facilities and Upgrades. Accordingly, as identified within the sections of this Article IV, certain provisions of this Article IV shall apply only if Modifications are made to the Interconnection Facilities, National Grid Transmission System or Customer System after the Effective Date of this Agreement.

4.2 Obtaining Real Property Interests, and Necessary Licenses, Permits, and Approvals.

4.2.1 Customer, or at Customer's request and at Customer's expense, National Grid will acquire all interests in real property that are necessary for National Grid to construct, operate and maintain any Modification in accordance with the terms and provisions of this Agreement.

4.2.2 National Grid, at Customer's sole cost and expense, shall be responsible for preparing and maintaining in full force and effect all permits, authorizations, licenses, certificates and approvals necessary to design, construct, operate and maintain the National Grid Interconnection Facilities and/or Modifications. Customer shall be responsible, at its own cost, for preparing and maintaining in full force and effect all permits, authorizations, licenses, certificates, and approvals necessary to design, construct, operate and maintain the Customer Interconnection Facilities and effectuate its obligations under the Agreement with respect to the National Grid Interconnection Facilities. National Grid, at Customer's sole cost and expense, shall fully cooperate with Customer in order to prepare and maintain all permits, authorizations, licenses, certificates and approvals required by this Section. Customer and National Grid agree to comply in all material respects with all federal, state and local environmental and other laws, ordinances, rules, regulations, permits, licenses, approvals, certificates and requirements thereunder in connection with the activities each performs pursuant to this Agreement.

4.2.3 Customer agrees that, prior to the transfer of any real property interest to

National Grid under the terms of this Agreement in connection with and as may be required by any Modification, Customer shall conduct, or cause to be conducted, sampling, soil testing, and any other methods of investigation which would disclose the presence of any Hazardous Substance which has been released on the property or which is present upon the property by migration from an external source on the property and shall notify National Grid in writing as soon as reasonably practicable after learning of the presence of Hazardous Substance upon said property interest. Customer shall provide National Grid with a copy of any report or data generated as a result of such sampling or soil testing activities. Customer agrees to indemnify, defend, and save National Grid, its agents and employees, harmless from and against any loss, damage, liability (civil or criminal), cost, suit, charge (including reasonable attorneys' fees), expense, or cause of action, for the removal or management of any Hazardous Substance relating to any damages to any person or property resulting from the presence of such Hazardous Substance.

- 4.2.4 National Grid, at Customer's sole cost and expense, shall be given the opportunity to inspect, be present for final testing and approve any Modification to the Customer Interconnection Facilities and review all appropriate approvals, certificates, permits, and authorizations relating thereto. Customer shall be responsible for correcting any situations contrary to Good Utility Practice, Bulletin No. 752, National Grid's standards, procedures, practices and functional specification requirements, standard National Grid environmental, construction, forestry, and right-of-way management practices and procedures, National Grid's Standard Environmental Management and Construction Plan Protection Measures and National Grid's Transmission Right-of-Way Management Plans or any applicable NYISO requirements, which such requirements shall govern in the event of a conflict between NYISO and the requirements of Bulletin No. 752, which materially and adversely affect the operability of the National Grid Interconnection Facilities or are contrary to applicable laws or permits, and for correcting any material deficiencies which could impede the National Grid Interconnection Facilities pursuant to this Agreement. Customer shall be responsible for the costs associated with making such corrections.
- 4.2.5 Customer shall be given the opportunity to inspect, be present for final testing and approve any Modification to the National Grid Interconnection Facilities and review all appropriate approvals, certificates, permits, and authorizations relating thereto. National Grid shall correct any situations contrary to Good Utility Practice, Bulletin No. 752, National Grid's standards, procedures, practices and functional specification requirements, standard National Grid environmental, construction, forestry, and right-of-way management practices and procedures, National Grid's Standard Environmental Management and Construction Plan Protection Measures and National Grid's Transmission Right-of-Way Management Plans or any applicable NYISO requirements, which such requirements shall govern in the event of a conflict between NYISO and the requirements of Bulletin No. 752, which materially and adversely affect the operability of the Interconnection Facilities or are contrary to applicable laws or

permits, and for correcting any material deficiencies which could impede the Interconnection Facilities pursuant to this Agreement. Prior to commercial operation, Customer shall provide National Grid with written acceptance of any Modification to the National Grid Interconnection Facilities.

4.3 National Grid Design, Engineering and Construction Activities.

- 4.3.1 At Customer's expense, National Grid agrees to design, engineer, and construct any Modifications in accordance with: (a) any Interconnection Study, (b) Good Utility Practice, and (c) National Grid's standards as identified in Exhibit B.
- 4.3.2 At Customer's expense, National Grid agrees to procure any and all equipment necessary for National Grid to construct any Modification to the National Grid Interconnection Facility.
- 4.3.3 All design, engineering, procurement, and construction activities in connection with and as may be required by any Modification performed by National Grid or a third party selected by National Grid shall be performed in accordance with a schedule and an estimated budget mutually agreed to by the Parties in advance of the commencement of such activities. National Grid, at Customer's expense, agrees to inform Customer on the first business day of each month and at such other times as Customer reasonably requests of the status of all design, engineering, procurement, and construction activities performed by National Grid or a third party selected by National Grid, including, but not limited to, the following information: progress to date; a description of upcoming scheduled activities and events; the delivery status of all ordered equipment; a revised budget and cost report; and the identification of any event which National Grid reasonably expects may delay construction of any Modification.
- 4.3.4 No design, engineering, procurement, or construction activities shall be undertaken by National Grid in connection with and as may be required by any Modification until such time as Customer issues a written notice to proceed with such activities and a money deposit received by National Grid for services to be rendered.
- 4.3.5 Customer reserves the right, upon thirty (30) Calendar Day prior written notice to National Grid, to suspend at any time all work by National Grid associated with the design, engineering, procurement, construction in connection with and as may be required by any Modifications. Customer acknowledges and agrees to reimburse National Grid for all costs incurred by National Grid that cannot be avoided, due to Customer's suspending said work in accordance with Article X of this Agreement. National Grid shall, if requested by Customer, use Reasonable Efforts to suspend work by National Grid in less than thirty (30) Calendar Days after National Grid receives notice from Customer.
- 4.3.6 National Grid shall, at Customer's expense, test any Modifications to ensure their

safe and reliable operation in accordance with Good Utility Practice.

4.4 Access Rights.

- 4.4.1 National Grid hereby grants to Customer access, and licenses, as Customer may require in connection with the construction, maintenance, operation, replacement, removal and/or permitting of Customer Modifications. National Grid hereby agrees to execute such grants, deeds, licenses, instruments or other documents as Customer may reasonable require to enable it to record such rights of way, easements, and licenses.
- 4.4.2 Customer hereby grants to National Grid all necessary access, and licenses, including adequate and continuing rights of access to Customer's property, as may be necessary for National Grid to construct, operate, maintain, replace, remove the National Grid Interconnection Facilities and or Modifications in accordance with the terms of this Agreement and to exercise any other of its obligations under this Agreement. Customer hereby agrees to execute such grants, deeds, licenses, instruments or other documents as National Grid may reasonably require to enable it to record such rights of way, easements, and licenses. Customer also grants to National Grid rights of access to Customer's property as may be necessary for National Grid to perform its obligations in connection with this Agreement.
- 4.5 All expenditures incurred by National Grid in acquiring franchises, necessary rights-of-way and associated permits and authorizations in connection with and as may be required by any Modifications shall be the sole responsibility of Customer. All costs associated with the transfer of real property rights to National Grid in connection with and as may be required by any Modifications shall also be the responsibility of Customer, including, but not limited to, closing costs, subdivision costs, transfer taxes and recording fees. National Grid shall be reimbursed for all costs it incurs in connection thereto and in carrying out the responsibilities hereunder as provided in Article X of this Agreement.
- 4.6 The rights-of-way for any Modification to the Interconnection Facilities constructed by Customer pursuant to this Agreement shall be conveyed to National Grid in fee simple or by an easement approved by National Grid, with good and marketable title free and clear of all liens and encumbrances for a sum of \$1.00. With respect to any approved conveyance of easements, Customer shall subordinate pertinent mortgages to easement rights. Customer shall indemnify, defend, and hold harmless National Grid, its agents and employees, from all liens and encumbrances against the property conveyed. Customer further agrees to provide a complete field survey with iron pin markers showing the centerline of the entire right-of-way, a 40-year abstract of title, and a 10-year tax search. Customer shall be required to provide National Grid, as a condition of and pursuant to conveyance to National Grid of any and all interests in real property acquired by Customer on behalf of National Grid for any Modification to the Interconnection Facilities, title insurance with a complete title report issued by a reputable title insurance company. In the event Customer is unable to convey to National Grid good and marketable title to any parcel of land acquired pursuant

to this Agreement in connection with and as may be required by any Modification, whether said defect in title is discovered prior to or after conveyance of said parcel of land, or in the event of a failure by Customer to comply with National Grid's engineering standards or any applicable law, code, rule or regulation in connection with and as may be required by any Modification, then Customer shall cure such defect or failure to comply, to the reasonable satisfaction of National Grid within six (6) months after receipt of written notice from National Grid to Customer specifying the defect or failure to comply or within such other time as the parties may agree. All expenses and costs associated with curing said defects or failure to comply shall be Customer's sole responsibility.

- 4.7 Each Party shall provide to the other Party copies of all necessary environmental, right-of-way, engineering, and other licenses, certificates, permits, approvals and as-built drawings related to any Modification.
- 4.8 Each Party shall also provide to the other, upon request and at the cost of the requesting Party, reasonable documentation necessary to verify costs relating to Modifications, including, but not limited to, any costs relating to the design, engineering, construction, operation or maintenance thereof. Each Party shall have the right to request reasonable supporting documents which are necessary to substantiate its costs.

ARTICLE V OPERATION, MAINTENANCE, AND MODIFICATION OF FACILITIES

5.1 Operation and Maintenance of Interconnection Facilities.

- 5.1.1 National Grid will own, operate, maintain and repair (repair includes, but is not limited to, replacement of existing equipment when required due to failure) the National Grid Interconnection Facilities in accordance with Good Utility Practice.
- 5.1.2 Customer, at its own expense, will own, operate, maintain and repair (repair includes, but is not limited to, replacement of existing equipment when required due to failure) Customer Interconnection Facilities in accordance with Good Utility Practice.
- 5.1.3 National Grid and Customer shall confer regularly to coordinate the planning, scheduling and performance of preventive and corrective maintenance on the Interconnection Facilities. Absent an Emergency Condition, the Parties will use Reasonable Efforts to schedule outages on a date and time mutually acceptable to both National Grid and the Customer. Customer will notify and coordinate with National Grid the schedule for scheduled outages for any Customer Interconnection Facilities the upcoming year in accordance with Bulletin No. 752, Good Utility Practice, NYISO practices, and National Grid standard practices, and, upon making any changes to such schedules thereafter, shall promptly notify and coordinate with National Grid regarding any such changes.

- 5.1.4 In furtherance of the Parties' mutual objective to preserve and maintain the reliability of the National Grid Transmission System and the Customer System, the Parties agree to coordinate the planning and scheduling of any outages and any changes thereto in a manner that will preserve and maintain the reliability of, and minimize the effect on, the National Grid Transmission System and the Customer System consistent with Good Utility Practice, Bulletin No. 752, NYISO practices, and National Grid standard practices.
- 5.1.5 In furtherance of the Parties' mutual objective to preserve and maintain the reliability of the National Grid Transmission System and the Customer System, the Parties agree, to coordinate the planning and scheduling of preventative and corrective maintenance in a manner that will preserve and maintain the reliability of the National Grid Transmission System and the Customer System. The Parties shall conduct preventative maintenance and corrective maintenance activities as scheduled and planned, or as they become necessary, consistent with Good Utility Practice.
- 5.1.6 If Customer requests that National Grid perform maintenance during a time period other than as scheduled by National Grid, National Grid will use Reasonable Efforts to meet Customer's request as long as meeting the request would not reasonably be expected to have an adverse impact upon National Grid's operations or the operations of National Grid's customers. Notwithstanding the foregoing, should Customer request to perform maintenance that National Grid in good faith determines may have an adverse impact on National Grid's operations or the operations of National Grid's customers, and if such maintenance may be delayed until after such period, National Grid may reject Customer's scheduling request. Customer shall reimburse National Grid for all costs incurred by National Grid in satisfying any Customer request pursuant to this Section 5.1.6.
- 5.1.7 Customer shall maintain its Customer Interconnection Facilities in a safe and reliable manner in accordance with this Agreement.
- 5.1.8 National Grid will maintain its National Grid Interconnection Facilities in a safe and reliable manner in accordance with this Agreement.

5.2 Modification of the Interconnection Facilities.

- 5.2.1 National Grid shall retain the discretion to determine whether, when, and in what manner Modifications to the National Grid Interconnection Facilities are required by Good Utility Practice and, as soon as reasonably practicable, but no later than three months advance written notice including an estimate of the cost of the Modification, shall advise Customer when it makes such a determination and whether performing the Modification, or the Modification itself, is expected to interrupt the flow of power over the Interconnection Facility. National Grid shall use Reasonable Efforts to minimize any interruption of power flow over or to the

Interconnection Facilities. Such notice shall include plans and, information relating to the impact of planned Modifications on the Customer System or Customer Interconnection Facilities, and/or National Grid's Transmission System. National Grid shall construct, operate, maintain and repair any such Modification, and Customer shall reimburse National Grid for all actual costs and expenses of constructing, operating and maintaining the Modification, except any such costs related to Modifications as may be required to facilitate the interconnection of one or more third parties to the National Grid Transmission System and/or New York State Transmission System.

5.2.2 Subject to Section 5.2.1, if a Modification to the National Grid Interconnection Facilities is required to support the operations of Customer, National Grid shall construct, operate, maintain and repair, at Customer's expense, any such Modification, and Customer shall reimburse National Grid for all actual costs and expenses of constructing the Modification. National Grid shall provide three months advance written notice including an estimate of the cost of the Modification to Customer to the extent reasonably practicable.

5.2.3 Customer shall give National Grid at least three months advance written notice of any planned Modifications to the Customer Interconnection Facilities.

5.2.3.1 Such notice shall include plans and information relating to the impact of planned Modifications on the National Grid Transmission System or the National Grid Interconnection Facilities, and the Customer System.

5.2.3.2 If National Grid reasonably determines that such Modification would have a material adverse effect upon National Grid's Interconnection Facilities or the National Grid Transmission System including the operation thereof, then National Grid shall so notify Customer. In the event that Customer elects to continue with such Modification, National Grid shall be entitled to designate the earliest date upon which Customer may begin the Modification, provided, however, that National Grid shall not designate a beginning date that is later than eighteen (18) months after receipt of the notice mandated by Section 5.2.3. Customer shall be responsible for all costs associated with such Modification, including any costs incurred by National Grid associated with ensuring that the National Grid Interconnection Facilities would be compatible with such Modification.

5.2.3.3 Notwithstanding the foregoing, should Customer propose a schedule for performing a Modification that National Grid in good faith reasonably determines may adversely affect National Grid's Interconnection Facilities or the National Grid Transmission System including the operation thereof, National Grid may reject such

schedule, but only to the extent such schedule is not in accordance with Good Utility Practice.

5.2.3.4 All Modifications to the National Grid Transmission System or the National Grid Interconnection Facilities, and any resulting effects on the National Grid Transmission System shall meet the applicable rules and requirements of NERC, NPCC, NYSRC, and the NYISO, the standards of Good Utility Practice, and the requirements of Bulletin No. 752; provided, however, that in the event of a conflict between the rules and requirements of the NYISO and the requirements of Bulletin No. 752, the rules and requirements of the NYISO shall govern.

5.2.4 If Customer is permitted by National Grid to construct, at its own expense, a Modification to the National Grid Interconnection Facilities subject to the terms of this Agreement, then Customer shall transfer all rights, title and interest in such Modification to National Grid upon completion of construction and shall execute all reasonably necessary documents to effectuate transfer of ownership thereof to National Grid, provided however, that design, engineering, and construction activities on to the existing National Grid Interconnection Facilities shall be performed by National Grid, or by a third party selected or approved by National Grid in accordance with Good Utility Practice and at Customer 's expense, Customer shall obtain any necessary permits, authorizations and rights-of-way for the Modification, in accordance with this Agreement, the costs thereof to be paid by Customer. Customer shall transfer any such rights-of-way to National Grid. National Grid will accept transfer of ownership and energize the Modification, upon Customer 's satisfaction, at Customer 's expense, of the following: (a) the modification shall comply with National Grid's engineering standards and all applicable laws, codes, rules and regulations; (b) the transfer of all rights of way necessary for the Modification shall be made in fee simple (by warranty deed free and clear of all liens and encumbrances) for consideration in the amount of One Dollar; and (c) a land survey and title insurance for the Modification shall be provided to National Grid by Customer in a form and amount reasonably acceptable to National Grid. The Customer shall be responsible for any and all taxes caused by the transfer of ownership.

5.3 Modification, Relocation, Rearrangement, Abandonment or Retirement of the National Grid Transmission System.

5.3.1 If, during the term of this Agreement, National Grid determines that it is required by Good Utility Practice to make a Modification, relocate, rearrange, abandon, or retire the National Grid Transmission System, National Grid shall use good faith efforts to give Customer no less than one (1) year advance written notice and shall, to the extent consistent with Good Utility Practice, defer such action, to the extent reasonably practicable, so that Customer's operation may continue with

minimal interruption.

- 5.3.2 If National Grid is required or ordered by a Governmental Authority or the NYISO to make a Modification, relocate, rearrange, abandon, or retire the National Grid Transmission System, National Grid shall use good faith efforts to give Customer no less than one (1) year advance written notice.
- 5.3.3 If the Modification, relocation, rearrangement, abandonment, or retirement is required pursuant to Section 5.3.1 or 5.3.2, National Grid shall perform or have performed, at Customer's expense, the studies necessary to identify any Modifications to the Interconnection Facilities or the Customer System necessary for continued operation and shall inform Customer of any estimated costs that may be assessed directly to Customer. Customer shall at its option either: (a) reimburse National Grid for all actual costs and expenses of such Modification to the Interconnection Facilities or the Customer System, studies and estimates in accordance with Article X of this Agreement; (b) construct, at its own expense, new Interconnection Facilities subject to the terms of this Agreement; provided, however, that design, engineering, and construction activities relating to the existing National Grid Transmission System and Interconnection Facilities shall be performed by National Grid, or by a third party selected or approved by National Grid at Customer's expense; or (c) terminate this Agreement, upon no less than sixty (60) Calendar Days advance written notice to National Grid.

5.4 **Interconnection of Third Party Facilities to Customer System.**

- 5.4.1 Customer will provide advance written notice to National Grid prior to the proposed interconnection to the Customer System of any: (1) new Generator ; (2) 10% increase or more in the capacity of an existing Generator connected to the Customer System ; or (3) peak load increases of 10% or greater over the peak load stated in Exhibit A. Such written notice shall be provided within 30 Calendar Days of Customer receiving an interconnection or service request or notice of a proposed increase in Generator capacity.
- 5.4.2 National Grid or the NYISO, as applicable, will have the right to perform an Interconnection Study in order to determine the extent of the impact of a proposed interconnection or increase in Generator capacity covered by Section 5.4.1 on the National Grid Transmission System. National Grid or the NYISO shall perform any such studies pursuant to any applicable NYISO requirements. If upgrades to the National Grid Transmission System are required as a result of the proposed interconnection or increase in Generator capacity, such upgrades will be performed by National Grid or a third party designated by National Grid at the expense of either the Customer, the owner of the Generator, or the owner of the load connecting to the Customer System and such responsible party shall reimburse National Grid for all actual costs and expenses of constructing, operating, and maintaining the upgrades. The party responsible for such costs shall be identified and agreed to prior to National Grid commencing any work with respect to such

upgrades.

ARTICLE VI POWER DELIVERIES

6.1 Metering.

- 6.1.1 Unless otherwise agreed to by National Grid and Customer, National Grid shall serve as the Metering Authority for Customer and shall perform, own and operate all metering required to measure electric service consumed by Customer.
- 6.1.2 In the case where a Generator exists within the Customer System, depending on the Generator size or its operational characteristics, including participation in the wholesale markets administered by the NYISO, additional metering equipment may be required to satisfy the requirements of the NYISO or National Grid.
- 6.1.3 Electricity received at the delivery points by Customer hereunder shall be measured by electric watt hour meters of a type approved by the NYPSC and NYISO. These metering facilities will be installed, owned, and maintained by National Grid, with the seal broken only upon occasions when the meters are to be inspected, tested or adjusted and representatives of both National Grid and Customer are present. The meters shall be maintained in accordance with the rules set forth in 16 NYCRR Part 92, as amended from time to time, and with Good Utility Practice.
- 6.1.4 In the event the Customer desires access to meter information other than such access as may be available to wholesale customers of the NYISO, Customer may, at its own expense, purchase and install software, hardware and/or other technology that may be required to access such meter information. The software, hardware and/or other technology installed for this purpose shall be in compliance with any applicable NYPSC and National Grid rules, requirements, or standards.
- 6.1.5 Customer grants to the employees and agents of National Grid the right of access to Customer Interconnection Facilities at all reasonable times for such purposes of the reading of meters; inspection of meters, their wiring and related equipment; and installing, operating, maintaining, disconnecting and removing of any or all of the property belonging to National Grid. If Customer refuses such access to the meters or other National Grid equipment, or if access is obstructed or hazardous, National Grid shall provide notice that Customer shall have five (5) Calendar Days in which to permit access, or remove any obstruction or hazard. If, after five (5) Calendar Days from the receipt of the notice, Customer does not permit access or remove any obstruction or hazard, it will constitute an event of breach, and National Grid may take any action in accordance with this Agreement, including disconnecting Customer from the Transmission System in accordance with Good Utility Practice, after providing reasonable notice.

6.2 **Losses.**

If the metering equipment and the Interconnection Point(s) are not at the same location, the metering equipment shall record delivery of Electricity in a manner that accounts for losses occurring between the metering points and the Interconnection Points, which shall be calculated by National Grid in a commercially reasonable manner consistent with Good Utility Practice. The metering point, the delivery points, associated equipment and distance between the metering point and the delivery points are set forth in Exhibit A. If the metering points are changed to another location, losses in accordance with this Section will be recalculated. In addition, Customer will be responsible for all costs associated with the change in metering points.

**ARTICLE VII
EMERGENCIES**

7.1 **Obligations.** Each Party shall comply with the Emergency State procedures of NYISO, the Applicable Reliability Councils, Applicable Laws and Regulations, and any emergency procedures of National Grid provided to the Customer.

7.2 **Notice.** NYISO or, as applicable, National Grid shall notify Customer promptly when it becomes aware of an Emergency State that affects the National Grid Interconnection Facilities or the National Grid Transmission System that may reasonably be expected to affect the Customer System. Customer shall notify NYISO and National Grid promptly when it becomes aware of an Emergency State that affects the Customer System that may reasonably be expected to affect the National Grid Interconnection Facilities or the New York State Transmission System. To the extent information is known, the notification required by this Section 7.2 shall describe the Emergency State, the extent of the damage or deficiency, the expected effect on the operation of Customer's or National Grid's facilities and operations, its anticipated duration and the corrective action taken and/or to be taken. The initial notice, if provided verbally, shall be followed as soon as reasonably practicable with written notice.

7.3 **Immediate Action.** Unless, in Customer's reasonable judgment, immediate action is required, Customer shall obtain the consent of National Grid, such consent to not be unreasonably withheld, prior to performing any manual switching operations at the Interconnection Facilities in response to an Emergency State either declared by NYISO, National Grid or otherwise regarding New York State Transmission System.

7.4 **NYISO and National Grid Authority.**

7.4.1 **General.** NYISO or National Grid may take whatever actions with regard to the New York State Transmission System (including the National Grid Transmission System) or the National Grid Interconnection Facilities it deems necessary during

an Emergency State in order to (i) preserve public health and safety, (ii) preserve the reliability of the New York State Transmission System or the National Grid Interconnection Facilities, (iii) limit or prevent damage, and (iv) expedite restoration of service.

NYISO and National Grid shall use Reasonable Efforts to minimize the effect of such actions or inactions on the Customer System. NYISO or National Grid may, on the basis of technical considerations, require the Customer System to mitigate an Emergency State by taking actions necessary and limited in scope to remedy the Emergency State.

Any actions taken by National Grid with respect to Customer or the Customer System shall not be unduly discriminatory or preferential.

- 7.4.2 **Disconnection.** NYISO or National Grid may disconnect the Customer System when disconnection is necessary under Good Utility Practice due to an Emergency State. These rights are separate and distinct from any right of Curtailment of NYISO pursuant to the NYISO OATT. When NYISO or National Grid can schedule the disconnection in advance, NYISO or National Grid shall notify Customer of the reasons, timing and expected duration of the disconnection. NYISO or National Grid shall coordinate with the Customer using Good Utility Practice to schedule the disconnection during periods of least impact to the Customer and the New York State Transmission System. Any disconnection pursuant to this Section 7.4.2 shall continue only for so long as reasonably necessary under Good Utility Practice. The Parties shall cooperate with each other to restore the Customer System, and the New York State Transmission System to their normal operating state as soon as practicable consistent with Good Utility Practice.
- 7.5 **Customer Authority.** Consistent with Good Utility Practice and this Agreement, the Customer may take whatever actions or inactions with regard to the Customer System or Customer Interconnection Facilities during an Emergency State in order to (i) preserve public health and safety, (ii) preserve the reliability of the Customer System or Customer Interconnection Facilities, (iii) limit or prevent damage, and (iv) expedite restoration of service. Customer shall use Reasonable Efforts to minimize the effect of such actions or inactions on the New York Transmission System and the National Grid Interconnection Facilities. NYISO and National Grid shall use Reasonable Efforts to assist Customer in such actions.
- 7.6 **Limited Liability.** Except as otherwise provided in the NYISO Tariffs, no Party shall be liable to another Party for any action it takes in responding to an Emergency State so long as such action is made in good faith and is consistent with Good Utility Practice and the NYISO Tariffs.

**ARTICLE VIII
INSURANCE PROVISIONS**

- 8.1 Customer agrees to maintain at its own expense insurance policies issued by reputable insurance companies acceptable to National Grid which provide insurance coverage which meets or exceeds the following requirements:
- 8.1.1 Workers Compensation and Employers Liability Insurance as required by the State of New York. If required, coverage shall include the U.S. Longshoremen's, and Harbor Workers Compensation Act & the Jones Act.
- 8.1.2 Public Liability (Including Contractual Liability), covering all activities and operations to be performed by it under this Agreement, with the following minimum limits:
- (A) Bodily Injury - \$1,000,000/\$1,000,000
Property Damage - \$1,000,000/\$1,000,000
OR
 - (B) Combined Single Limit - \$1,000,000
OR
 - (C) Bodily Injury and Property Damage per Occurrence - \$1,000,000
General Aggregate & Product Aggregate - \$2,000,000 each.
- 8.1.3 Umbrella or Excess Liability, coverage with a minimum limit of \$ 4,000,000.
- 8.2 Customer shall name National Grid as an additional insured for all coverage's except Workers Compensation and Employers Liability Insurance in order to provide National Grid protection from liability arising out of activities of Customer relating to the Interconnection Facilities, and/or the Upgrades as the case may be.
- 8.3 In the event Customer uses subcontractors in connection with this Agreement, Customer shall require all subcontractors to provide the same insurance coverage's set forth in Sections 8.1.1, 8.1.2 and 8.1.3.
- 8.4 Upon request by National Grid, Customer shall promptly provide National Grid with either evidence of insurance or certificates of insurance evidencing the insurance coverage required under Sections 8.1.1, 8.1.2, 8.1.3 and 8.2. Customer shall provide such certificates or evidence of insurance to National Grid at the following address:

**Transmission Commercial
National Grid
40 Sylvan Rd
Waltham, MA. 02451**

Such certificates, and any renewals or extensions thereof, shall provide that at least thirty

(30) Calendar Days prior written notice shall be given to National Grid in the event of any cancellation or diminution of coverage and shall outline the amount of deductibles or self-insured retention's which shall be for the account of the insured Party.

- 8.5 If Customer fails to secure or maintain any insurance coverage, or any insurance coverage is canceled before the completion of all services provided under this Agreement, and Customer fails immediately to procure such insurance as specified herein, then National Grid has the right to procure such insurance and, at its option, either bill the cost thereof to Customer or deduct the cost thereof from any sum due Customer under this Agreement.
- 8.6 To the extent requested, Customer shall furnish to National Grid with copies of any accident report(s) sent to Customer's insurance carriers covering accidents or incidents occurring in connection with or as a result of the performance of the work under this Agreement.
- 8.7 Customer shall comply with any governmental and/or site specific insurance requirements even if not stated herein.
- 8.8 By the Effective Date of this Agreement, Customer represents that it will have full policy limits available and shall notify National Grid in writing when coverage's required herein have been reduced as a result of claim payments, expenses, or both.
- 8.9 Nothing contained in these insurance requirements is to be construed as (A) limiting the extent, if any, to which Customer is responsible for payment of damages, or (B) limiting, diminishing, or waiving the obligation of Customer to indemnify, defend and save harmless National Grid in accordance with this Agreement.

**ARTICLE IX
COMPLIANCE WITH LAWS**

- 9.1 National Grid and Customer each agree to comply in all material respects with all applicable federal, state and local laws, ordinances, rules, regulations, permits, licenses, approvals, certificates, and requirements thereunder in connection with all its activities performed pursuant to this Agreement, including, but not limited to all design, environmental, regulatory, engineering, construction, and property acquisition activities.
- 9.2 If either Party observes that any requirement specified in this Agreement is at variance with any governing laws, ordinances, rules, regulations, permits, licenses, approvals, certificates and requirements thereunder, such Party shall promptly notify the other in writing before incurring any further liability, expense or obligation. National Grid and Customer shall in good faith attempt to reform this Agreement to comply with the aforementioned laws, ordinances, rules, regulations, permits, approvals, or certificates. If National Grid and Customer are unable to do so, either Party may terminate this Agreement.

- 9.3 **Environmental Releases by Customer.** Customer shall notify National Grid first verbally, and then in writing, of the release of Hazardous Substances as soon as possible but not later than twenty-four (24) hours after the incident, and shall promptly furnish to National Grid copies of any reports filed with any governmental agencies addressing such events. If Hazardous Substances are released or reasonably believed to have been released by Customer onto National Grid's property, Customer, at its own expense, shall conduct, or cause to be conducted, sampling, soil testing, and any other methods of investigation which would disclose the presence and extent of contamination by any Hazardous Substance which has been released onto National Grid's property and shall notify National Grid in writing as soon as reasonably practicable after learning of the presence of any Hazardous Substance upon National Grid's property. Customer shall provide National Grid with a copy of any report or data generated as a result of such sampling or soil testing activities. Customer shall notify National Grid immediately of any type of remediation activities. Customer shall provide National Grid thirty (30) Calendar Days written notice prior to conducting any asbestos or lead abatement activities, and shall promptly furnish to National Grid (i) copies of any reports filed with any governmental or regulatory agencies pertaining to such abatement activities, (ii) copies of applications for permits to conduct abatement activities, and (iii) copies of all permits authorizing abatement activities. Customer agrees to indemnify, defend, and save harmless National Grid, its agents and employees, from and against any loss, damage, liability (civil or criminal), cost, suit, charge (including reasonable attorneys' fees), expense, or cause of action, for the removal or management of any Hazardous Substance and/or relating to any damages to any person or property resulting from presence of such Hazardous Substance.
- 9.4 **Environmental Releases by National Grid.** National Grid shall notify Customer first verbally, and then in writing, of the release of Hazardous Substances as soon as possible but not later than twenty-four (24) hours after the incident, and shall promptly furnish to Customer copies of any reports filed with any governmental agencies addressing such events. If Hazardous Substances are released or reasonably believed to have been released by National Grid onto Customer's property, National Grid, at its own expense, shall conduct, or cause to be conducted, sampling, soil testing, and any other methods of investigation which would disclose the presence and extent of contamination by any Hazardous Substance which has been released onto Customer's property and shall notify Customer in writing as soon as reasonably practicable after learning of the presence of any Hazardous Substance upon Customer's property. National Grid shall notify Customer immediately of any type of remediation activities. National Grid shall provide Customer thirty (30) Calendar Days written notice prior to conducting any asbestos or lead abatement activities, and shall promptly furnish to Customer (i) copies of any reports filed with any governmental or regulatory agencies pertaining to such abatement activities, (ii) copies of applications for permits to conduct abatement activities, and (iii) copies of all permits authorizing abatement activities. National Grid agrees to indemnify, defend, and save harmless Customer, its agents and employees, from and against any loss, damage, liability (civil or criminal), cost, suit, charge (including reasonable attorneys' fees), expense, or cause of action, for the removal or management of any Hazardous Substance and/or

relating to any damages to any person or property resulting from presence of such Hazardous Substance.

- 9.5 Both Parties shall promptly provide to the other Party upon request, all relevant information, documents, or data which may reasonably be expected to pertain to the safety, security or reliability of the immediate Transmission System to which Customer is connected.

ARTICLE X COST PAYMENTS

- 10.1 National Grid shall invoice Customer monthly in an amount equal to National Grid's actual costs and expenses for which National Grid is to be reimbursed under this Agreement. However, if and as requested by National Grid, Customer shall reimburse National Grid for costs and expenses in advance of National Grid incurring the aforementioned costs or expenses. If National Grid requires advance payment pursuant to this Section 10.1, National Grid shall use Reasonable Efforts to develop a mutually acceptable schedule for any such advance payments.
- 10.2 Customer shall pay National Grid within thirty (30) Calendar Days of invoicing for all costs incurred by National Grid under this Agreement for which Customer is responsible pursuant to the terms and conditions of this Agreement, including, as applicable, but not limited to, the cost of: constructing Modifications; relocations, rearrangements, abandonments or retirements; operation, maintenance, repair and spare parts; metering, telemetering and communication media; and miscellaneous studies, testing, documentation and items performed by National Grid at the request of Customer.
- 10.2.1 To the extent Customer is responsible pursuant to the terms and conditions of this Agreement for the actual costs of National Grid, such costs may include, as applicable, but may not be limited to, capital costs, labor (direct and distributable); labor fringe benefits and payroll taxes; invoices for material, contractors, consultants, etc.; employee expenses; storeroom material and handling; any and all costs and expenses resulting from damage to National Grid property not otherwise covered by insurance, including risk of loss of Modifications during construction; sales and/or use taxes on invoices and material; transportation; allowance for funds used during construction (“AFUDC”); administrative and general expense (“A&G”) at the current rate applied to the total of all costs; and state, county, local sales and use taxes applied to the total of all costs and administrative and general and expenses associated with the acquisition, ownership, operation, repair, spare parts, A&G, inspection, design review, engineering, surveying, project management and coordination, testing of electrical equipment and installation of energy management system remote terminal units and revenue meters, construction, construction monitoring, financing, maintenance, environmental and regulatory permitting and licensing of, taxes and transfer of title of any new facilities

and Modifications.

- 10.2.2 Customer shall be responsible for any and all costs or expenses that are incurred by National Grid pursuant to this Agreement for the operation, maintenance and repair of the Interconnection Facilities including any Modifications transferred to National Grid
- 10.2.2.1 Customer shall reimburse National Grid on a monthly basis for operation, maintenance, and repair costs and expenses. However, if and as requested by National Grid, Customer shall reimburse National Grid for operation, maintenance, and repair costs and expenses in advance of National Grid incurring the aforementioned costs or expenses. If National Grid requires advance payment pursuant to this Section 10.2.2.1, National Grid shall use Reasonable Efforts to develop a mutually acceptable schedule for any such advance payments.
- 10.2.2.2 Reimbursable operation, maintenance and repair costs and expenses shall include all actual costs and expenses associated with operation, maintenance, repair, spare parts, inspection, engineering and legal services, contract administration, right-of-way acquisition, A&G, working capital (including material adders, overhead charges, and transportation charges), and allowed earnings and/or rates of return approved by a regulatory body having jurisdiction.
- 10.2.3 Customer shall be responsible for all legal fees, costs, liabilities, judgments, fines, penalties and other sanctions against National Grid arising out of Customer's exercise of eminent domain powers, except to the extent that such fees, costs, liabilities, judgments, fines, penalties and other sanctions are attributable to the rightful exercise of such powers.
- 10.2.4 Customer shall be responsible for any and all federal, state, local, and foreign taxes levied or assessed upon National Grid for payments made to National Grid by Customer for services provided under this Agreement including, but not limited to, the following: transfer tax, property tax, federal income tax, and New York State taxes, including New York income or gross receipts, sales and use taxes; provided, however, that National Grid shall pay any applicable interest or penalty incurred as a result of National Grid's delay in paying such taxes or seeking reimbursement from Customer. If any form of tax, other than income or excess profits tax, under any present or future federal, state or other law different from or in addition to the taxes for which participation in or payment by Customer is provided herein or elsewhere in this Agreement, is required to be paid, levied or assessed against or incurred by National Grid with respect to any property, property right, commodity, or service involved in, resulting from or accruing from National Grid's performance

under this Agreement, which such different or additional tax would not be required to be paid by National Grid in the absence of this Agreement and, with respect to such different or additional tax, no obligation of Customer to participate or pay would have attached under the provisions of this Agreement elsewhere than in this Section, then in such event Customer shall fully reimburse National Grid for the full amount of such different or additional tax paid by National Grid.

10.2.4.1 If National Grid receives a refund from the taxing authorities of any amounts paid by Customer, National Grid shall refund to Customer such amount refunded National Grid (net of expenses related to obtaining the refund) within thirty (30) Calendar Days of receiving such refund.

10.2.4.2 Notwithstanding the foregoing, Customer, at its own expense, shall have the right to require National Grid to seek a Private Letter Ruling from the Internal Revenue Service on whether any of the sums paid to National Grid by Customer under the terms of this Agreement for the construction of the facilities contemplated herein are subject to U.S. federal taxation. To the extent that the Private Letter Ruling concludes that any such sums are taxable to National Grid., Customer shall reimburse National Grid for all such taxes consequently imposed upon National Grid in accordance with the terms of this Agreement. Customer shall reimburse National Grid for all costs, including but not limited to legal fees, associated with seeking the Private Letter Ruling.

10.2.5 Increased income tax to National Grid arising from Customer's payment or reimbursement of tax under the preceding provisions will be addressed in the following manner. Any net actual U.S. federal income tax or New York State tax (collectively, for this Section 10.2.5 "Tax"), if any, arising out of any payment or reimbursement of any tax by Customer under this Article shall be reimbursed to National Grid. The amount reimbursed to National Grid under this Section shall consist of (1) the Tax arising under this Section (the "First Amount"); plus (2) the net actual Tax imposed on the First Amount (the "Second Amount"); plus (3) the net actual Tax imposed on the Second Amount (the "Third Amount"); and plus (4) the net actual Tax imposed on the Third Amount and on each succeeding amount until the final amount is less than one dollar.

10.2.6 If Customer is generally exempt from taxation, Customer shall provide to National Grid all documentation reasonably required by National Grid to verify Customer's tax exemption status.

10.3 National Grid agrees to cooperate with the Customer in attempting to minimize National Grid's costs under this Agreement, provided Customer reimburses National Grid for all costs incurred by National Grid in connection with such cooperation, including reasonable attorneys' fees and expenses, and provided further that Customer shall indemnify, defend, and save harmless National Grid, its agents and employees, against any and all penalties, judgments, fines (civil or criminal), or other costs that may be imposed by any

Governmental Authority as a result hereof. Where reasonably practicable, National Grid shall provide Customer with advance notice of any costs National Grid expects to incur under this Section 10.3 and, if Customer objects to reimbursing National Grid for such costs, National Grid shall be under no obligation to incur such costs.

- 10.4 National Grid shall include with each invoice, documentation supporting the costs, expenses, and/or taxes incurred by National Grid. National Grid will provide such documentation from its standard accounting methods. Within thirty (30) Calendar Days from date of the invoice, Customer shall pay the invoice and/or notify National Grid that Customer disputes, in whole or in part, any of the costs, expenses, and/or taxes reflected in the invoice and shall specify with particularity the reasons for such dispute. If Customer disputes any invoice or portion thereof, Customer shall immediately place into an independent escrow account an amount equal to the portion of the invoice it disputes. Such amount shall remain in escrow until the dispute between the Parties is resolved in accordance with Article XXI of this Agreement. If any portion of any invoice Customer has not disputed remains unpaid thirty (30) Calendar Days from the invoice date, National Grid shall apply to the unpaid balance, and Customer shall pay, a finance charge at the rate of one and one-half percent (1.5%) per month, but in no event more than the maximum allowed by law.
- 10.5 **Disputes.** In the event of a billing dispute between National Grid and Customer, National Grid will continue to perform under this Agreement as long as Customer: (i) continues to make all payments not in dispute; and (ii) pays to National Grid or into an independent escrow account the portion of the invoice in dispute, pending resolution of such dispute. If Customer fails to meet these two requirements for continuation of service, then National Grid may provide notice to Customer of a Default.

ARTICLE XI NOTICES

- 11.1 All notices required or permitted under this Agreement shall be in writing and shall be personally delivered or sent by certified or registered first class mail (return receipt requested, postage prepaid), facsimile transmission, or overnight express mail or courier service addressed as follows:

To Customer:

Daniel L. Maneen
President and Chief Executive Officer
Griffiss Utility Services Corporation
410 Phoenix Drive
Rome, NY 13441
Fax: 315-838-4877

To National Grid:

William L. Malee
Director, Transmission Commercial
National Grid
40 Sylvan Road
Waltham, MA 02451
Fax: 7810907-5707

- 11.1.1 All notices required for billing purposes under this Agreement shall be in writing and shall be delivered to the following address:

To Customer:

Daniel L. Maneen
President and Chief Executive Officer
Griffiss Utility Services Corporation
410 Phoenix Drive
Rome, NY 13441
Fax: 315-838-4877

To National Grid:

William L. Malee
Director, Transmission Commercial
National Grid
40 Sylvan Road
Waltham, MA 02451
Fax: 781-907-5707

11.1.2 Notice shall be deemed effective on the date received so long as received during normal business hours on a Business Day, otherwise, notice shall be effective on the next Business Day.

- 11.2 Either Party may change its address for notices without an amendment to this Agreement by notice to the other in the manner provided above.
- 11.3 Notwithstanding Section 11.1, any notice hereunder, with respect to an Emergency Condition or other occurrence requiring prompt attention, shall be communicated in an expedited manner and may be made by telephone provided that such notice is confirmed in writing as soon as reasonably practicable thereafter.
- 11.4 The representatives noted in Section 11.1 and/or their designees shall be authorized to act on behalf of the Parties, and their instructions, requests, and decisions will be binding upon the Parties as to all matters pertaining to this Agreement and the performance of the Parties hereunder. Only these representatives shall have the authority to commit funds or make binding obligations on behalf of the Parties. The Parties shall be permitted to change their respective representatives by providing notice to the other party of the change of representative.

ARTICLE XII TERM AND TERMINATION

- 12.1 This Agreement shall become effective as of the date first above written (the "EFFECTIVE DATE"), subject to its approval or acceptance for filing by the FERC (if applicable) or if filed unexecuted, upon the date specified by the FERC, and shall continue in effect for twenty (20) years thereafter.
- 12.2 This Agreement shall not merge with or be terminated or superseded by any future agreement between the Parties that does not specifically so provide.
- 12.3 In the event either National Grid or Customer abandons its work or facilities under this Agreement; becomes insolvent; or assigns or sublets this Agreement in a manner inconsistent with this Agreement, or is violating any of the material conditions, terms, obligations, or covenants of this Agreement, or is not performing this Agreement in good faith, the other Party may terminate this Agreement by providing written notice. Before

instituting proceedings before FERC to terminate the Agreement, National Grid must give Customer written notice of the reasons for termination. If, within a period of ten (10) Calendar Days of receiving such notice, Customer or National Grid cures the default or breach cited by the other in such written notice, to the reasonable satisfaction of the Party that provided such notice, and shall have complied with the provisions of this Agreement, such notice shall become null and void and of no effect. Otherwise, such notice shall remain in effect and, except to the extent expressly provided for herein, the obligations of the Parties under this Agreement shall terminate ten (10) Calendar Days after such notice was provided.

- 12.4 In the event of a billing dispute between National Grid and Customer, National Grid shall not remove the Interconnection Facilities or any part of the National Grid Transmission System from service or terminate transmission service thereon unless specifically authorized to do so under Applicable Laws and Regulations. Customer shall not be in default under this Agreement as long as Customer: (i) continues to make all payments and (ii) adheres to the dispute resolution procedures set forth in Article XXI of this Agreement and pays into an independent escrow account the portion of any invoice in dispute, pending resolution of such dispute. If Customer fails to meet the foregoing two requirements, then a default shall be deemed to exist, to which appropriate procedures set forth in this Article XII shall apply.
- 12.5 Termination of this Agreement shall not relieve Customer or National Grid of any of its liabilities and obligations arising hereunder prior to the date termination becomes effective, and Customer or National Grid may take whatever judicial or administrative actions as appear necessary or desirable to enforce its rights hereunder. The rights specified herein are not exclusive and shall be in addition to all other remedies available to either Party, either at law or in equity, for default or breach of any provision of this Agreement; provided, however, that in no event shall National Grid or Customer be liable for any incidental, special, indirect, exemplary or consequential costs, expenses, or damages sustained by the other, as provided for in Article XXII hereto.
- 12.6 In the event of termination of this Agreement, National Grid, at its sole option and at Customer's expense, will physically disconnect Customer from the National Grid Transmission System. In the event of a disconnection, National Grid may return the Transmission System to its original state prior to this Agreement, and remove any or all of National Grid Interconnection Facilities equipment.

ARTICLE XIII FORCE MAJEURE

- 13.1 Economic hardship is not considered a Force Majeure event.
- 13.2 Neither Party shall be considered to be in default or breach hereunder, and shall be excused from performance hereunder, if and to the extent that it shall be delayed in or prevented from performing or carrying out any provisions of this Agreement by reason of

Force Majeure.

- 13.3 The Party claiming Force Majeure shall give notice to the other Party of the occurrence of Force Majeure as soon as reasonably practicable after such occurrence and shall use due diligence to resume performance or the provision of service hereunder as soon as reasonably practicable.

ARTICLE XIV INDEMNIFICATION

- 14.1 Each Party (the “Indemnifying Party”) shall at all times indemnify, defend, and save harmless, as applicable, the other Parties (each an “Indemnified Party”) from, any and all damages, losses, claims, including claims and actions relating to injury to or death of any person or damage to property, the alleged violation of any Environmental Law, or the release or threatened release of any Hazardous Substance, demand, suits, recoveries, costs and expenses, court costs, attorney fees, and all other obligations by or to third parties, arising out of or resulting from (i) the Indemnified Party’s performance of its obligations under this Agreement on behalf of the Indemnifying Party, except in cases where the Indemnifying Party can demonstrate that the Loss of the Indemnified Party was caused by the gross negligence or intentional wrongdoing of the Indemnified Party or (ii) the violation by the Indemnifying Party of any Environmental Law or the release by the Indemnifying Party of any Hazardous Substance.
- 14.2 If a Party is entitled to indemnification under this Article XIV as a result of a claim by a third party, and the indemnifying Party fails, after notice and reasonable opportunity to proceed under Section 14.4, to assume the defense of such claim, such Indemnified Party may at the expense of the Indemnifying Party contest, settle or consent to the entry of any judgment with respect to, or pay in full, such claim.
- 14.3 If an Indemnifying Party is obligated to indemnify and hold any Indemnified Party harmless under this Article XIV, the amount owing to the Indemnified Party shall be the amount of such Indemnified Party’s actual Loss, net of any insurance or other recovery.
- 14.4 Promptly after receipt by an Indemnified Party of any claim or notice of the commencement of any action or administrative or legal proceeding or investigation as to which the indemnity provided for in Section 14.1 may apply, the Indemnified Party shall notify the Indemnifying Party of such fact. Any failure of or delay in such notification shall not affect a Party’s indemnification obligation unless such failure or delay is materially prejudicial to the Indemnifying Party.

Except as stated below, the Indemnifying Party shall have the right to assume the defense thereof with counsel designated by such Indemnifying Party and reasonably satisfactory to the Indemnified Party. If the defendants in any such action include one or more Indemnified Parties and the Indemnifying Party and if the Indemnified Party reasonably

concludes that there may be legal defenses available to it and/or other Indemnified Parties which are different from or additional to those available to the Indemnifying Party, the Indemnified Party shall have the right to select separate counsel to assert such legal defenses and to otherwise participate in the defense of such action on its own behalf. In such instances, the Indemnifying Party shall only be required to pay the fees and expenses of one additional attorney to represent an Indemnified Party or Indemnified Parties having such differing or additional legal defenses.

The Indemnified Party shall be entitled, at its expense, to participate in any such action, suit or proceeding, the defense of which has been assumed by the Indemnifying Party. Notwithstanding the foregoing, the Indemnifying Party (i) shall not be entitled to assume and control the defense of any such action, suit or proceedings if and to the extent that, in the opinion of the Indemnified Party and its counsel, such action, suit or proceeding involves the potential imposition of criminal liability on the Indemnified Party, or there exists a conflict or adversity of interest between the Indemnified Party and the Indemnifying Party, in such event the Indemnifying Party shall pay the reasonable expenses of the Indemnified Party, and (ii) shall not settle or consent to the entry of any judgment in any action, suit or proceeding without the consent of the Indemnified Party, which shall not be unreasonably withheld, conditioned or delayed.

- 14.5 The obligations set forth in this Article XIV shall survive the later of the completion of the work, termination or expiration of the Agreement.

ARTICLE XV RELATIONSHIP OF THE PARTIES

- 15.1 Nothing contained in this Agreement shall be construed or deemed to cause, create, constitute, give effect to, or otherwise recognize Customer and National Grid to be partners, joint venturers, employer and employee, principal and agent, or any other business association, with respect to any matter.
- 15.2 Unless otherwise agreed to in writing signed by both Parties, neither Party shall have any authority to create or assume in the other Party's name or on its behalf any obligation, express or implied, or to act or purport to act as the other Party's agent or legal empowered representative for any purpose whatsoever.
- 15.3 Neither Party shall be liable to any third party in any way for any engagement, obligation, commitment, contract, representation or for any negligent act or omission of the other Party, except as expressly provided for herein.
- 15.4 The rights and obligations of the Parties shall be limited to those expressly set forth herein.

ARTICLE XVI
THIRD PARTY BENEFICIARY/ASSIGNMENT

- 16.1 No person or party shall have any rights or interests, direct or indirect, in this Agreement or the services or facilities to be provided hereunder, or both, except the Parties, their successors, and authorized assigns.
- 16.2 The Parties specifically disclaim any intent to create any rights in any person or party as a third-party beneficiary to this Agreement.
- 16.3 Except as provided for in Sections 16.3.1, 16.3.2 and 16.3.3, neither Party may assign this Agreement or any of its rights, interests, or obligations hereunder without the prior written consent of the other Party, which such consent shall not be unreasonably withheld.
- 16.3.1 Customer may, with only prior written notice to National Grid, assign, transfer, pledge, or otherwise dispose of its rights and interests under this Agreement to any lender or financial institution in connection with the financing or refinancing of the Customer Interconnection Facilities or property acquisition therefore. Furthermore, Customer may, with only prior written notice to National Grid, assign, transfer, pledge or otherwise dispose of its rights and interests under this Agreement to any Affiliate or Griffiss Local Development Corporation.
- 16.3.2 National Grid may, with only prior written notice to Customer, assign, transfer, pledge, or otherwise dispose of National Grid's rights and interests under this Agreement to any lender or financial institution in connection with the financing or refinancing of the Transmission System or property acquisition therefor.
- 16.3.3 Any company or entity which succeeds by purchase, merger or consolidation of the properties and assets, substantially or entirely, of National Grid or Customer shall be entitled to the rights and shall be subject to the obligations of National Grid or Customer under this Agreement.
- 16.4 Each Party agrees to reimburse the other Party for any costs and expenses (including reasonable attorneys' fees) incurred in connection with the other Party's review, execution and delivery of instruments, agreements or documents necessary in connection with the assigning Party's assignment, transfer, sale or other disposition of this Agreement or any interest in the Interconnection Facilities or the National Grid Transmission System, provided that no such reimbursement shall be due for any costs and expenses for the review of a notice that both Parties agree is authorized under Section 16.3.1.
- 16.5 Any assignment in violation of Article XVI shall be considered null and void from its inception, and each Party reserves the right to proceed with a regulatory or judicial resolution concerning the continued operation of the Interconnection Facilities.
- 16.6 Any authorized assignment shall not relieve the assigning Party of the responsibility of full

compliance with the requirements of this Agreement arising prior to the effective date of assignment, unless the other Party consents and the assignee agrees in writing to be bound by all of the obligations and duties of the assigning Party provided for in this Agreement and has provided written assurances to the other Party of continued performance and protection against liability upon assignment.

- 16.7 Assignment contrary to the provisions of this Agreement shall make the assigning Party the indemnitor of the other Party and its successors against any liabilities and costs, including reasonable attorneys' fees as to which the assigning Party's transferee fails to indemnify, defend, and hold harmless the other Party, its agents, employees and its successors, from and against any loss, damage, liability, cost, suit, charge, expense (including reasonable attorney's fees) or cause of action, incurred by the other Party as a result of said assignment or as a result of any dispute between the assigning Party and its transferees, or between any subsequent transferees, that arises from or relates to any assignment by the assigning Party.

ARTICLE XVII APPROVAL

- 17.1 National Grid shall file this Agreement with the appropriate regulatory authorities. If any such regulatory body materially modifies the terms and conditions of this Agreement and such modification(s) materially affect the benefits flowing to one or both of the Parties, the Parties agree to attempt in good faith to negotiate an amendment or amendments to this Agreement or take other appropriate action(s) so as to put each Party in effectively the same position in which the Parties would have been had such modification not been made. In the event that, within sixty (60) Calendar Days or some other time period mutually agreed upon by the Parties after such modification has been made, the Parties are unable to reach agreement as to what, if any, amendments are necessary and fail to take other appropriate action to put each Party in effectively the same position in which the Parties would have been had such modification not been made, then either Party shall have the right to unilaterally terminate this Agreement.

ARTICLE XVIII WAIVER

- 18.1 No provision of this Agreement may be waived except by mutual agreement of the Parties as expressed in writing and signed by both Parties.
- 18.2 Any waiver that is not in writing and signed by both Parties shall be null and void from its inception.
- 18.3 No express waiver in any specific instance as provided in a required writing shall be construed as a waiver of future instances unless specifically so provided in the required writing.
- 18.4 No express waiver of any specific default shall be deemed a waiver of any other default whether or not similar to the default waived, or a continuing waiver of any other right or

default by a Party.

- 18.5 The failure of either Party to insist in any one or more instances upon the strict performance of any of the provisions of this Agreement, or to exercise any right herein, shall not be construed as a waiver or relinquishment for the future of such strict performance of such provision or the exercise of such right.

**ARTICLE XIX
AMENDMENT AND MODIFICATION**

- 19.1 This Agreement may be amended or modified if the amendment or modification is in writing and executed by both Parties.
- 19.2 No express amendment or modification in any specific instance as provided herein shall be construed as an amendment or modification of future instances, unless specifically so provided in the required writing.
- 19.3 Nothing in this Agreement shall be construed as affecting in any way the right of National Grid to unilaterally make application to FERC (or any successor agency) for a change in rates, terms and conditions, charges, classifications of service, rule or regulation under Section 205 of the FPA and pursuant to FERC's rules and regulations promulgated thereunder.

**ARTICLE XX
GOVERNING LAW**

- 20.1 This Agreement and the rights and obligations of the Parties to this Agreement shall be governed by and construed in accordance with the laws of the State of New York, without giving effect to the conflict of laws principles thereof.
- 20.2 Customer and National Grid agree to submit to the jurisdiction of the courts in the State of New York for the purposes of interpretation and enforcement of this Agreement.
- 20.3 Customer and National Grid waive personal service by manual delivery and agree that service of process on Customer or National Grid in any action concerning or arising out of this Agreement may be made by registered or certified mail, return receipt requested, delivered to Customer or National Grid at the addresses set forth in Article XI of this Agreement.
- 20.4 This Agreement is subject to all Applicable Laws and Regulations.
- 20.5 Each Party expressly reserves the right to seek changes in, appeal, or otherwise contest any laws, orders, rules, or regulations of a Governmental Authority.
- 20.6 Subject to the procedures of Article XXI, each Party reserves all rights under Applicable

Laws and Regulations to raise issues and disputes related to this Agreement in the appropriate legal and/or regulatory forum.

ARTICLE XXI DISPUTE RESOLUTION

- 21.1 Should a claim or dispute among the Parties arise under this Agreement, the Parties shall continue, in good faith, to perform their respective obligations hereunder. Notice of any claim or dispute that any Party may have against another Party, arising out of the Agreement shall be submitted in writing to the other Parties in a manner that clearly identifies the nature of the claim or dispute and requests that the Parties engage in negotiations to resolve the claim or dispute.
- 21.2 Upon receipt of the notice of claim or dispute under Section 21.1, the Parties shall use Reasonable Efforts to resolve any such dispute without resorting to judicial resolution, through good faith negotiations between representatives with authority to resolve or settle the claim or dispute. The Parties agree to keep confidential any documents or materials exchanged and/or confidential information revealed in furtherance of resolving or settling the claim or dispute under this Article XXI of this Agreement and that such documents, materials, or information shall be considered confidential settlement information and that, pursuant to Rule 408 of the Federal Rules of Evidence and parallel doctrines of state law, shall not be admissible as evidence in any subsequent judicial or regulatory proceeding.
- 21.3 If the dispute remains unresolved for more than sixty (60) Calendar Days (or such other period as may be mutually agreed to by the Parties in writing) after receipt of the notice of claim or dispute under Section 21.1, any Party may seek resolution of its rights and remedies under this Agreement through any available forum in accordance with the terms and conditions of this Agreement.

ARTICLE XXII LIMITATION OF LIABILITY

- 22.1 Notwithstanding any other provision of this Agreement, neither Party shall be responsible to the other for incidental, indirect, exemplary, special or consequential damages (including punitive damages or loss of profits) in connection with this Agreement, except in cases of intentional misconduct, unless otherwise stated in this Agreement.
- 22.2 **Survival.** The provisions of this Article shall apply regardless of fault and shall survive termination, cancellation, suspension, completion or expiration of this Agreement.

**ARTICLE XXIII
CONFIDENTIALITY**

23.1 **Confidentiality.** Certain information exchanged by the Parties during the term of this Agreement shall constitute confidential information ("Confidential Information") and shall be subject to this Article XXIII.

If requested by a Party receiving information, the Party supplying the information shall provide in writing, the basis for asserting that the information referred to in this Article warrants confidential treatment, and the requesting Party may disclose such writing to the appropriate Governmental Authority. Each Party shall be responsible for the costs associated with affording confidential treatment to its information.

23.1.1 **Term.** During the term of this Agreement, and for a period of three (3) years after the expiration or termination of this Agreement, except as otherwise provided in this Article XXIII, each Party shall hold in confidence and shall not disclose to any person Confidential Information.

23.1.2 **Confidential Information.** The following shall constitute Confidential Information: (1) any non-public information that is treated as confidential by the disclosing Party and which the disclosing Party identifies as Confidential Information in writing at the time, or promptly after the time, of disclosure; or (2) information designated as Confidential Information by the NYISO Code of Conduct contained in Attachment F to the NYISO OATT.

23.1.3 **Scope.** Confidential Information shall not include information that the receiving Party can demonstrate: (1) is generally available to the public other than as a result of a disclosure by the receiving Party; (2) was in the lawful possession of the receiving Party on a non-confidential basis before receiving it from the disclosing Party; (3) was supplied to the receiving Party without restriction by a third party, who, to the knowledge of the receiving Party after due inquiry, was under no obligation to the disclosing Party to keep such information confidential; (4) was independently developed by the receiving Party without reference to Confidential Information of the disclosing Party; (5) is, or becomes, publicly known, through no wrongful act or omission of the receiving Party or Breach of this Agreement; or (6) is required, in accordance with Section 23.1.8 of this Agreement, Order of Disclosure, to be disclosed by any Governmental Authority or is otherwise required to be disclosed by law or subpoena, or is necessary in any legal proceeding establishing rights and obligations under this Agreement. Information designated as Confidential Information will no longer be deemed confidential if the Party that designated the information as confidential notifies the other Party that it no longer is confidential.

23.1.4 **Release of Confidential Information.** No Party shall release or disclose Confidential Information to any other person, except to its Affiliates (limited

by FERC Standards of Conduct requirements), subcontractors, employees, consultants, or to parties who may be or considering providing financing to or equity participation with Customer, or to potential purchasers or assignees of a Party, on a need-to-know basis in connection with this Agreement, unless such person has first been advised of the confidentiality provisions of this Article XXIII and has agreed to comply with such provisions. Notwithstanding the foregoing, a Party providing Confidential Information to any person shall remain primarily responsible for any release of Confidential Information in contravention of this Article XXIII.

- 23.1.5 **Rights.** Each Party retains all rights, title, and interest in the Confidential Information that each Party discloses to the other Party. The disclosure by each Party to the other Parties of Confidential Information shall not be deemed a waiver by any Party or any other person or entity of the right to protect the Confidential Information from public disclosure.
- 23.1.6 **No Warranties.** By providing Confidential Information, no Party makes any warranties or representations as to its accuracy or completeness. In addition, by supplying Confidential Information, no Party obligates itself to provide any particular information or Confidential Information to the other Parties nor to enter into any further agreements or proceed with any other relationship or joint venture.
- 23.1.7 **Standard of Care.** Each Party shall use at least the same standard of care to protect Confidential Information it receives as it uses to protect its own Confidential Information from unauthorized disclosure, publication or dissemination. Each Party may use Confidential Information solely to fulfill its obligations to the other Party under this Agreement or its regulatory requirements, including the NYISO OATT and NYISO Services Tariff. The NYISO shall, in all cases, treat the information it receives in accordance with the requirements of Attachment F to the NYISO OATT.
- 23.1.8 **Order of Disclosure.** If a court or a Government Authority or entity with the right, power, and apparent authority to do so requests or requires any Party, by subpoena, oral deposition, interrogatories, requests for production of documents, administrative order, or otherwise, to disclose Confidential Information, that Party shall provide the other Parties with prompt notice of such request(s) or requirement(s) so that the other Parties may seek an appropriate protective order or waive compliance with the terms of this Agreement. Notwithstanding the absence of a protective order or waiver, the Party may disclose such Confidential Information which, in the opinion of its counsel, the Party is legally compelled to disclose. Each Party will use Reasonable Efforts to obtain reliable assurance that confidential treatment will be accorded any Confidential Information so furnished.
- 23.1.9 **Termination of Agreement.** Upon termination of this Agreement for any

reason, each Party shall, within ten (10) Calendar Days of receipt of a written request from the other Parties, use Reasonable Efforts to destroy, erase, or delete (with such destruction, erasure, and deletion certified in writing to the other Parties) or return to the other Parties, without retaining copies thereof, any and all written or electronic Confidential Information received from the other Parties pursuant to this Agreement.

- 23.1.10 **Remedies.** The Parties agree that monetary damages would be inadequate to compensate a Party for another Party's Breach of its obligations under this Article XXIII. Each Party accordingly agrees that the other Parties shall be entitled to seek equitable relief, by way of injunction or otherwise, if the first Party Breaches or threatens to Breach its obligations under this Article XXIII, which equitable relief shall be granted without bond or proof of damages, and the receiving Party shall not plead in defense that there would be an adequate remedy at law. Such remedy shall not be deemed an exclusive remedy for the Breach of this Article XXIII, but shall be in addition to all other remedies available at law or in equity. The Parties further acknowledge and agree that the covenants contained herein are necessary for the protection of legitimate business interests and are reasonable in scope. No Party, however, shall be liable for indirect, incidental, or consequential or punitive damages of any nature or kind resulting from or arising in connection with this Article XXIII.
- 23.1.11 **Disclosure to FERC, its Staff, or a State.** Notwithstanding anything in this Article XXIII to the contrary, and pursuant to 18 C.F.R. section 1b.20, if FERC or its staff, during the course of an investigation or otherwise, requests information from one of the Parties that is otherwise required to be maintained in confidence pursuant to this Agreement or the NYISO OATT, the Party shall provide the requested information to FERC or its staff, within the time provided for in the request for information. In providing the information to FERC or its staff, the Party must, consistent with 18 C.F.R. section 388.112, request that the information be treated as confidential and non-public by FERC and its staff and that the information be withheld from public disclosure. Parties are prohibited from notifying the other Parties to this Agreement prior to the release of the Confidential Information to the Commission or its staff. The Party shall notify the other Parties to the Agreement when it is notified by FERC or its staff that a request to release Confidential Information has been received by FERC, at which time the Parties may respond before such information would be made public, pursuant to 18 C.F.R. section 388.112. Requests from a state regulatory body conducting a confidential investigation shall be treated in a similar manner if consistent with the applicable state rules and regulations. A Party shall not be liable for any losses, consequential or otherwise, resulting from that Party divulging Confidential Information pursuant to a FERC or state regulatory body request under this paragraph.
- 23.1.12 Except as otherwise expressly provided herein, no Party shall disclose Confidential Information to any person not employed or retained by the Party

possessing the Confidential Information, except to the extent disclosure is (i) required by law; (ii) reasonably deemed by the disclosing Party to be required to be disclosed in connection with a dispute between or among the Parties, or the defense of litigation or dispute; (iii) otherwise permitted by consent of the other Party, such consent not to be unreasonably withheld; or (iv) necessary to fulfill its obligations under this Agreement, the NYISO OATT or the NYISO Services Tariff. Prior to any disclosures of a Party's Confidential Information under this subparagraph, or if any third party or Governmental Authority makes any request or demand for any of the information described in this subparagraph, the disclosing Party agrees to promptly notify the other Party in writing and agrees to assert confidentiality and cooperate with the other Party in seeking to protect the Confidential Information from public disclosure by confidentiality agreement, protective order or other reasonable measures.

ARTICLE XXIV SEVERABILITY

24.1 If any term of this Agreement, or the interpretation or application of any term or provision to any prior circumstance, is held to be unenforceable, illegal, or invalid by any governmental agency or court of competent jurisdiction, the remainder of this Agreement, or the interpretation or application of all other terms or provisions to persons or circumstances other than those that are unenforceable, illegal, or invalid, shall not be affected thereby and each term and provision shall be valid and be enforced to the fullest extent permitted by law.

ARTICLE XXV HEADINGS

25.1 The headings in this Agreement are included herein for convenience of reference only and shall not constitute a part of this Agreement for any other purpose, or limit or be used as an aid in construing the provisions of this Agreement.

ARTICLE XXVI INFORMATION ACCESS AND AUDIT RIGHTS

26.1 **Information Access.** Each Party (“Disclosing Party”) shall make available to another Party (“Requesting Party”) information that is in the possession of the Disclosing Party and is necessary in order for the Requesting Party to: (i) verify the costs incurred by the Disclosing Party for which the Requesting Party is responsible under this Agreement; and (ii) carry out its obligations and responsibilities under this Agreement. The Parties shall not use such information for purposes other than those set forth in this Section 26.1 of this Agreement and to enforce their rights under this Agreement.

26.2 **Reporting of Non-Force Majeure Events.** Each Party (the “Notifying Party”) shall notify the other Parties when the Notifying Party becomes aware of its inability to comply with the provisions of this Agreement for a reason other than a Force Majeure event. The Parties agree to cooperate with each other and provide necessary information

regarding such inability to comply, including the date, duration, reason for the inability to comply, and corrective actions taken or planned to be taken with respect to such inability to comply. Notwithstanding the foregoing, notification, cooperation or information provided under this Article shall not entitle the Party receiving such notification to allege a cause for anticipatory breach of this Agreement.

26.3 **Audit Rights.** Subject to the requirements of confidentiality under Article XXIII of this Agreement, each Party shall have the right, during normal business hours, and upon prior reasonable notice to another Party, to audit at its own expense the other Party's accounts and records pertaining to the other Party's performance or satisfaction of its obligations under this Agreement. Such audit rights shall include audits of the other Party's costs, calculation of invoiced amounts, and each Party's actions in an Emergency Condition. Any audit authorized by this Article shall be performed at the offices where such accounts and records are maintained and shall be limited to those portions of such accounts and records that relate to the Party's performance and satisfaction of obligations under this Agreement. Each Party shall keep such accounts and records for a period equivalent to the audit rights periods described in Section 26.4 of this Agreement.

26.4 **Audit Rights Periods.**

26.4.1 **Audit Rights Period for Construction-Related Accounts and Records.**

Accounts and records related to the design, engineering, procurement, and construction of Interconnection Facilities and Upgrades shall be subject to audit for a period of twenty-four months following National Grid's issuance of a final invoice concerning these Interconnection Facilities and Upgrades.

26.4.2 **Audit Rights Period for All Other Accounts and Records.** Accounts and records related to a Party's performance or satisfaction of its obligations under this Agreement other than those described in Section 26.4.1 of this Agreement shall be subject to audit as follows: (i) for an audit relating to cost obligations, the applicable audit rights period shall be twenty-four months after the auditing Party's receipt of an invoice giving rise to such cost obligations; and (ii) for an audit relating to all other obligations, the applicable audit rights period shall be twenty-four months after the event for which the audit is sought.

26.5 **Audit Results.** If an audit by a Party determines that an overpayment or an underpayment has occurred, a notice of such overpayment or underpayment shall be given to the other Party together with those records from the audit which support such determination.

**ARTICLE XXVII
SUBCONTRACTORS**

27.1 **General.** Nothing in this Agreement shall prevent a Party from utilizing the services of any subcontractor as it deems appropriate to perform its obligations under this Agreement; provided, however, that each Party shall require its subcontractors to

comply with all applicable terms and conditions of this Agreement in providing such services and each Party shall remain primarily liable to the other Parties for the performance of such subcontractor.

- 27.2 **Responsibility of Principal.** The creation of any subcontract relationship shall not relieve the hiring Party of any of its obligations under this Agreement. The hiring Party shall be fully responsible to the other Parties for the acts or omissions of any subcontractor the hiring Party hires as if no subcontract had been made; provided, however, that in no event shall National Grid be liable for the actions or inactions of the Customer or its subcontractors with respect to obligations of the Customer related to the construction of Interconnection Facilities. Any applicable obligation imposed by this Agreement upon the hiring Party shall be equally binding upon, and shall be construed as having application to, any subcontractor of such Party.
- 27.3 **No Limitation by Insurance.** The obligations under this Article XXVII will not be limited in any way by any limitation of subcontractor's insurance.

ARTICLE XXVIII COMPLIANCE WITH GOOD UTILITY PRACTICE

- 28.1 The Parties shall comply with Good Utility Practice.

ARTICLE XXIX COUNTERPARTS

- 29.1 This Agreement may be executed in two or more counterparts, each of which shall be deemed an original but all of which together shall constitute one and the same instrument.

ARTICLE XXX MISCELLANEOUS

- 30.1 **Binding Effect.** This Agreement and the rights and obligations hereof, shall be binding upon and shall inure to the benefit of the successors and permitted assigns of the Parties hereto.
- 30.2 **Conflicts.** If there is a discrepancy or conflict between or among the terms and conditions of this cover agreement and the Appendices hereto, the terms and conditions of this cover agreement shall be given precedence over the Appendices, except as otherwise expressly agreed to in writing by the Parties.
- 30.3 **Rules of Interpretation.** This Agreement, unless a clear contrary intention appears, shall be construed and interpreted as follows: (1) the singular number includes the plural number and vice versa; (2) reference to any person includes such person's successors and assigns but, in the case of a Party, only if such successors and assigns are permitted by

this Agreement, and reference to a person in a particular capacity excludes such person in any other capacity or individually; (3) reference to any agreement (including this Agreement), document, instrument or tariff means such agreement, document, instrument, or tariff as amended or modified and in effect from time to time in accordance with the terms thereof and, if applicable, the terms hereof; (4) reference to any Applicable Laws and Regulations means such Applicable Laws and Regulations as amended, modified, codified, or reenacted, in whole or in part, and in effect from time to time, including, if applicable, rules and regulations promulgated thereunder; (5) unless expressly stated otherwise, reference to any Article, Section or Appendix means such Article of this Agreement or such Appendix to this Agreement; (6) “hereunder”, “hereof”, “herein”, “hereto” and words of similar import shall be deemed references to this Agreement as a whole and not to any particular Article or other provision hereof or thereof; (7) “including” (and with correlative meaning “include”) means including without limiting the generality of any description preceding such term; and (8) relative to the determination of any period of time, “from” means “from and including”, “to” means “to but excluding” and “through” means “through and including”.

- 30.4 **Compliance.** Each Party shall perform its obligations under this Agreement in accordance with Applicable Laws and Regulations, Applicable Reliability Standards, the NYISO OATT and Good Utility Practice. To the extent a Party is required or prevented or limited in taking any action by such regulations and standards, such Party shall not be deemed to be in Breach of this Agreement for its compliance therewith. When any Party becomes aware of such a situation, it shall notify the other Parties promptly so that the Parties can discuss the amendment to this Agreement that is appropriate under the circumstances.
- 30.5 **Entire Agreement.** This Agreement, including all Appendices, Attachments, Exhibits and Schedules attached hereto, constitutes the entire agreement between the Parties with reference to the subject matter hereof, and supersedes all prior and contemporaneous understandings or agreements, oral or written, between the Parties with respect to the subject matter of this Agreement. There are no other agreements, representations, warranties, or covenants which constitute any part of the consideration for, or any condition to, either Party’s compliance with its obligations under this Agreement.

IN WITNESS WHEREOF, the Parties hereto have caused this instrument to be executed as of the day and year first above written.

Niagara Mohawk Power Corporation
d/b/a National Grid

By: Will J. Mal

Title: Director, Transmission Commercial

Date: 2/16/12

Griffiss Utility Services Corporation

By: Daniel M. Mace

Title: President and Chief Executive Officer

Date: 2/8/12

Exhibit A

Customer shall take delivery of electric service at Griffiss Air Force Base Substation #2 (Ellsworth Rd Substation).

The Interconnection Point(s) are the connection of National Grid's Booneville – Rome Line #4 to the terminal pads of Disconnect Switches 41 and 43.

National Grid's Interconnection Facilities are the conductor that makes up Booneville – Rome Line #4. This includes the conductor between Structure #12 and Disconnect Switch 41 and the conductor between Structure #11 and Disconnect Switch 43.

Customer owns all of the equipment in the Transmission Substation known as Griffiss Air Force Base Substation #2 (Ellsworth Rd Substation). This includes Disconnect Switches 41, 42, 43, and the conductor and structures between them. It is noted that the series circuit through Disconnect Switches 41, 42, & 43 is part of the Booneville – Rome Line #4 Transmission Circuit. This is relevant to various sections in Articles III, IV, and V, as coordinated operation and maintenance of Disconnect Switches 41, 42, 43 is necessary for the operational integrity of Booneville – Rome Line #4.

Below is the Operating Diagram of Booneville – Rome Line #4:

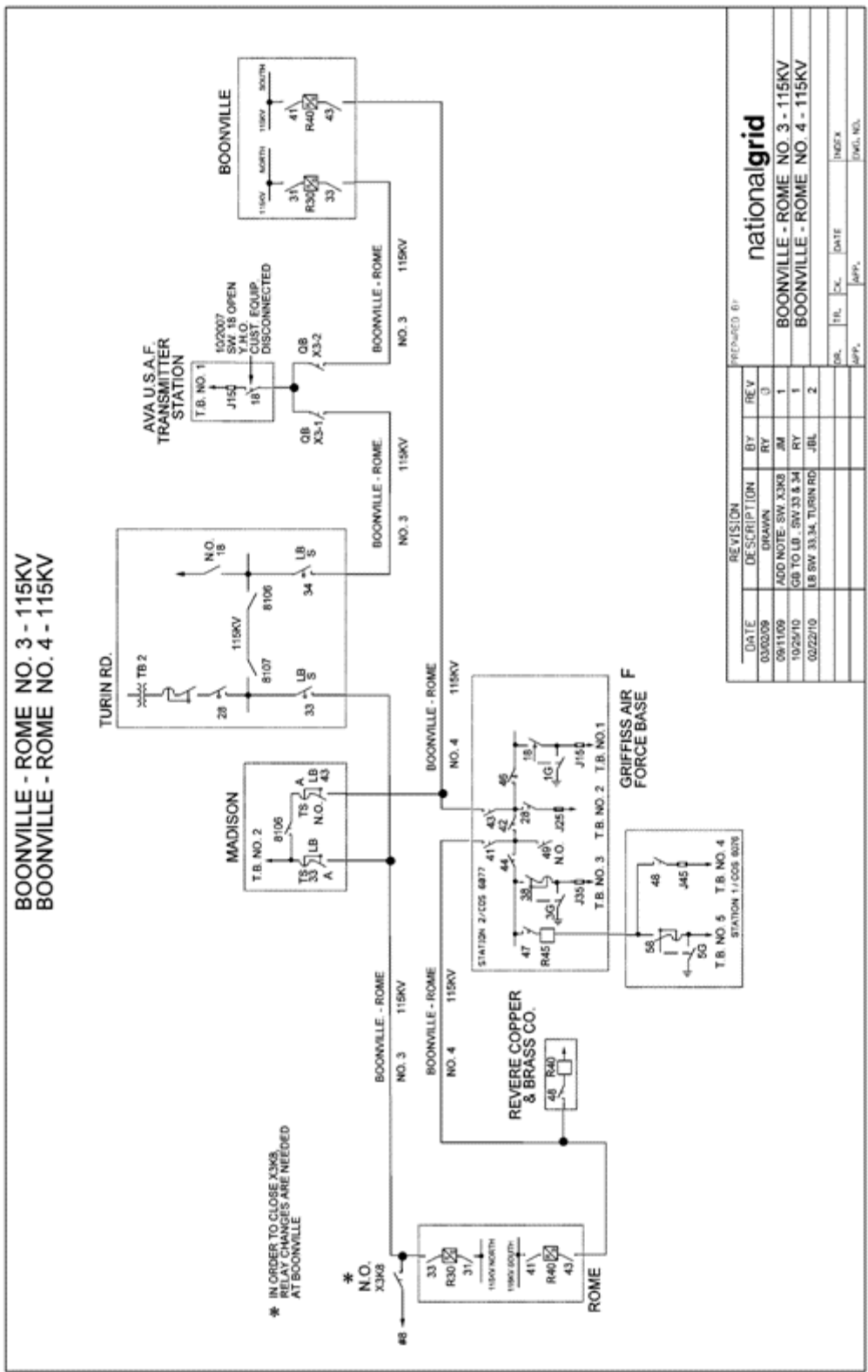

Exhibit B

[Electric System Bulletin No. 752]

National Grid's standards for electrical requirements referenced in this Agreement include: ESB-750; ESB-752; ESB-755 and ESB-756, which are available at the following link on National Grid's website:

https://www.nationalgridus.com/niagaramohawk/construction/3_elec_specs.asp