

**SMALL GENERATOR
INTERCONNECTION AGREEMENT (SGIA)**

**Between Niagara Mohawk Power Corporation d/b/a nationalgrid and WM
Renewables, LLC for the Monroe-Livingston Counties Landfill Generation Facility**

TABLE OF CONTENTS

Article 1. Scope and Limitations of Agreement	Error! Bookmark not defined.
1.5 Responsibilities of the Parties	Error! Bookmark not defined.
1.6 Parallel Operation Obligations.....	Error! Bookmark not defined.
1.7 Metering.....	Error! Bookmark not defined.
1.8 Reactive Power	Error! Bookmark not defined.
Article 2. Inspection, Testing, Authorization, and Right of Access.....	Error! Bookmark not defined.
Article 2.1 Equipment Testing and Inspection.....	Error! Bookmark not defined.
Article 2.2 Authorization Required Prior to Parallel Operation	Error! Bookmark not defined.
Article 2.3 Right of Access	Error! Bookmark not defined.
Article 3. Effective Date, Term, Termination, and Disconnection	Error! Bookmark not defined.
Article 3.1 Effective Date	Error! Bookmark not defined.
Article 3.2 Term of Agreement.....	Error! Bookmark not defined.
Article 3.3 Termination.....	Error! Bookmark not defined.
Article 3.4 Temporary Disconnection.....	Error! Bookmark not defined.
3.4.1 Emergency Conditions.....	Error! Bookmark not defined.
3.4.2 Routine Maintenance, Construction, and Repair	Error! Bookmark not defined.
Article 3.4.3 Forced Outages	Error! Bookmark not defined.
Article 3.4.4 Adverse Operating Effects	Error! Bookmark not defined.
Article 3.4.5 Modification of the Small Generating Facility ..	Error! Bookmark not defined.
Article 3.4.6 Reconnection.....	Error! Bookmark not defined.
Article 4. Cost Responsibility for Interconnection Facilities and Distribution Upgrades	Error! Bookmark not defined.
Article 4.1 Interconnection Facilities.....	Error! Bookmark not defined.
Article 4.2 Distribution Upgrades	Error! Bookmark not defined.
Article 5. Cost Responsibility for Network Upgrades	Error! Bookmark not defined.
Article 5.1 Applicability	Error! Bookmark not defined.
Article 5.2 Network Upgrades	Error! Bookmark not defined.
5.2.1 Repayment of Amounts Advanced for Network Upgrades	Error! Bookmark not defined.
Article 5.3 Special Provisions for Affected Systems	Error! Bookmark not defined.
Article 5.4 Rights Under Other Agreements.....	Error! Bookmark not defined.
Article 6. Billing, Payment, Milestones, and Financial Security .	Error! Bookmark not defined.
Article 6.1 Billing and Payment Procedures and Final Accounting	Error! Bookmark not defined.
Article 6.2 Milestones	Error! Bookmark not defined.
Article 6.3 Financial Security Arrangements.....	Error! Bookmark not defined.
Article 7. Assignment, Liability, Indemnity, Force Majeure, Consequential Damages,	Error! Bookmark not defined.
Article 7.1 Assignment	Error! Bookmark not defined.
Article 7.2 Limitation of Liability.....	Error! Bookmark not defined.
Article 7.3 Indemnity	Error! Bookmark not defined.

7.4 Consequential Damages.....	Error! Bookmark not defined.
7.5 Force Majeure.....	Error! Bookmark not defined.
7.6 Default.....	Error! Bookmark not defined.
Article 8. Insurance.....	Error! Bookmark not defined.
Article 9. Confidentiality.....	Error! Bookmark not defined.
Article 10. Disputes.....	Error! Bookmark not defined.
Article 11. Taxes.....	Error! Bookmark not defined.
Article 12. Miscellaneous.....	Error! Bookmark not defined.
12.1 Governing Law, Regulatory Authority, and Rules.....	Error! Bookmark not defined.
12.2 Amendment.....	Error! Bookmark not defined.
12.3 No Third-Party Beneficiaries.....	Error! Bookmark not defined.
12.4 Waiver.....	Error! Bookmark not defined.
12.5 Entire Agreement.....	Error! Bookmark not defined.
12.6 Multiple Counterparts.....	Error! Bookmark not defined.
12.7 No Partnership.....	Error! Bookmark not defined.
12.8 Severability.....	Error! Bookmark not defined.
12.9 Security Arrangements.....	Error! Bookmark not defined.
12.10 Environmental Release.....	Error! Bookmark not defined.
12.11 Subcontractors.....	Error! Bookmark not defined.
12.12 Reservation of Rights.....	Error! Bookmark not defined.
Article 13. Notices.....	Error! Bookmark not defined.
13.1 General.....	Error! Bookmark not defined.
13.2 Billing and Payment.....	Error! Bookmark not defined.
13.3 Alternative Form of Notice.....	Error! Bookmark not defined.
13.4 Designated Operating Representative.....	Error! Bookmark not defined.
13.5 Changes to the Notice Information.....	Error! Bookmark not defined.
Article 14. Signatures.....	Error! Bookmark not defined.

Attachment 1 – Glossary of Terms

Attachment 2 – Description and Costs of the Small Generating Facility, Interconnection Facilities, and Metering Equipment

Attachment 3 – One-line Diagram Depicting the Small Generating Facility, Interconnection Facilities, Metering Equipment, and Upgrades

Attachment 4 – Milestones

Attachment 5 – Additional Operating Requirements for the Transmission owner's Transmission System and Affected Systems Needed to Support the Interconnection Customer's Needs

Attachment 6 – Transmission Owner's Description of its Upgrades and Best Estimate of Upgrade Costs

This Interconnection Agreement (“Agreement”) is made and entered into this _____ day of _____, 2011 by Niagara Mohawk Power Corporation d/b/a nationalgrid (“Transmission Owner”), and WM Renewable Energy, L.L.C. _ (“Interconnection Customer”) each hereinafter sometimes referred to individually as “Party” or both referred to collectively as the “Parties”.

Transmission Owner Information

Transmission Owner ” Niagara Mohawk Power Corporation d/b/a nationalgrid
_ Attention: Vice President Transmission Commercial Services
City: Waltham State: MA Zip:
Phone: 718-907-5706 Fax: 718-907-5707

Interconnection Customer Information

Interconnection Customer”
Attention: ___ WM Renewable Energy, L.L.C. _____
City: Houston State: TX Zip: 77433
Phone: 713-265-1672 Fax: 713-287-2423

Interconnection Customer Application No: N/A

In consideration of the mutual covenants set forth herein, the Parties agree as follows:

Article 1. Scope and Limitations of Agreement

- 1.1 This Agreement shall be used for all Interconnection Requests submitted under the Small Generator Interconnection Procedures (SGIP) except for those submitted under the 10 kW Inverter Process contained in SGIP Attachment 5.
- 1.2 This Agreement governs the terms and conditions under which the Interconnection Customer’s Small Generating Facility will interconnect with, and operate in parallel with, the Transmission Provider’s Transmission System.
- 1.3 This Agreement does not constitute an agreement to purchase or deliver the Interconnection Customer’s power The purchase or delivery of power and other services that the Interconnection Customer may require will be covered under separate agreements. The Interconnection Customer will be responsible for separately making all necessary arrangements (including scheduling) for delivery of electricity with the New York Independent System Operator (Transmission Provider).
- 1.4 Nothing in this Agreement is intended to affect any other agreement between the Transmission Owner and the Interconnection Customer.

1.5 Responsibilities of the Parties

- 1.5.1 The Parties shall perform all obligations of this Agreement in accordance with all Applicable Laws and Regulations, Operating Requirements, and Good Utility Practice.
- 1.5.2 The Interconnection Customer shall construct, interconnect, operate and maintain its Small Generating Facility and construct, operate, and maintain its Interconnection Facilities in accordance with the applicable manufacturer's recommended maintenance schedule, in accordance with this Agreement, and with Good Utility Practice.
- 1.5.3 The Transmission Owner shall construct, operate, and maintain its Transmission System and Interconnection Facilities in accordance with this Agreement, and with Good Utility Practice.
- 1.5.4 The Interconnection Customer agrees to construct its facilities or systems in accordance with applicable specifications that meet or exceed those provided by the National Electrical Safety Code, the American National Standards Institute, IEEE, Underwriter's Laboratory, and Operating Requirements in effect at the time of construction and other applicable national and state codes and standards. The Interconnection Customer agrees to design, install, maintain, and operate its Small Generating Facility so as to reasonably minimize the likelihood of a disturbance adversely affecting or impairing the system or equipment of the Transmission Owner or Affected Systems.
- 1.5.5 Each Party shall operate, maintain, repair, and inspect, and shall be fully responsible for the facilities that it now or subsequently may own unless otherwise specified in the Attachments to the Agreement. Each Party shall be responsible for the safe installation, maintenance, repair and condition of their respective lines and appurtenances on their respective sides of the point of change of ownership. The Transmission Owner and the Interconnection Customer, as appropriate, shall provide Interconnection Facilities that adequately protect the Transmission Owner's Transmission System, personnel, and other persons from damage and injury. The allocation of responsibility for the design, installation, operation, maintenance and ownership of Interconnection Facilities shall be delineated in the Attachments to the Agreement.
- 1.5.6 The Transmission Owner shall coordinate with all Affected Systems to support the interconnection.

1.6 Parallel Operation Obligations

Once the Small Generating Facility has been authorized to commence parallel operation, the Interconnection Customer shall abide by all rules and procedures pertaining to the parallel operation of the Small Generating Facility in the applicable control area, including, but not limited to; 1) the rules and procedures concerning the operation of generation set forth in the Tariff and / or by the Transmission Owner for the Transmission Provider's Transmission System and; 2) the Operating Requirements set forth in Attachment 5 of this Agreement.

1.7 Metering

The Interconnection Customer shall be responsible for the Transmission Owner's reasonable and necessary cost for the purchase, installation, operation, maintenance, testing, repair, and replacement of metering and data acquisition equipment specified in Attachments 2 and 3 of this Agreement. The Interconnection Customer's metering (and data acquisition, as required) equipment shall conform to applicable industry rules and Operating Requirements.

1.8 Reactive Power

1.8.1 The Interconnection Customer shall design its Small Generating Facility to maintain a composite power delivery at continuous rated power output at the Point of Interconnection at a power factor within the range of 0.95 leading to 0.95 lagging, unless the Transmission Provider has established different requirements that apply to all similarly situated generators in the control area on a comparable basis. The requirements of this paragraph shall not apply to wind generators.

1.8.2 The Transmission Provider is required to pay the Interconnection Customer for reactive power that the Interconnection Customer provides or absorbs from the Small Generating Facility when the Transmission Provider requests the Interconnection Customer to operate its Small Generating Facility outside the range specified in Article 1.8.1.

1.8.3 Payments shall be in accordance with the Tariff.

1.9 Capitalized terms used herein shall have the meanings specified in the Glossary of Terms in Attachment 1 or the body of this Agreement.

Article 2. Inspection, Testing, Authorization, and Right of Access

2.1 Equipment Testing and Inspection

- 2.1.1 The Interconnection Customer shall test and inspect its Small Generating Facility and Interconnection Facilities prior to interconnection. The Interconnection Customer shall notify the Transmission Owner of such activities no fewer than five Business Days (or as may be agreed to by the Parties) prior to such testing and inspection. Testing and inspection shall occur on a Business Day. The Transmission Owner may, at its own expense, send qualified personnel to the Small Generating Facility site to inspect the interconnection and observe the testing. The Interconnection Customer shall provide the Transmission Owner a written test report when such testing and inspection is completed.
- 2.1.2 The Transmission Owner shall provide the Interconnection Customer written acknowledgment that it has received the Interconnection Customer's written test report. Such written acknowledgment shall not be deemed to be or construed as any representation, assurance, guarantee, or warranty by the Transmission Owner of the safety, durability, suitability, or reliability of the Small Generating Facility or any associated control, protective, and safety devices owned or controlled by the Interconnection Customer or the quality of power produced by the Small Generating Facility.

2.2 Authorization Required Prior to Parallel Operation

- 2.2.1 The Transmission Owner shall use Reasonable Efforts to list applicable parallel operation requirements in Attachment 5 of this Agreement. Additionally, the Transmission Owner shall notify the Interconnection Customer of any changes to these requirements as soon as they are known. The Transmission Owner shall make Reasonable Efforts to cooperate with the Interconnection Customer in meeting requirements necessary for the Interconnection Customer to commence parallel operations by the in-service date.
- 2.2.2 The Interconnection Customer shall not operate its Small Generating Facility in parallel with the Transmission Owners Transmission System without prior written authorization of the Transmission Owner. The Transmission Owner will provide such authorization once the Transmission Provider receives notification that the Interconnection Customer has complied with all applicable parallel operation requirements. Such authorization shall not be unreasonably withheld, conditioned, or delayed.

2.3 Right of Access

- 2.3.1 Upon reasonable notice, the Transmission Owner may send a qualified person to the premises of the Interconnection Customer at or immediately before the time the Small Generating Facility first produces energy to inspect the interconnection, and observe the commissioning of the Small Generating Facility (including any required testing), startup, and operation for a period of up to three Business Days after initial start-up of the unit. In addition, the Interconnection Customer shall notify the Transmission Owner at least five Business Days prior to conducting any on-site verification testing of the Small Generating Facility.
- 2.3.2 Following the initial inspection process described above, at reasonable hours, and upon reasonable notice, or at any time without notice in the event of an emergency or hazardous condition, the Transmission Owner shall have access to the Interconnection Customer's premises for any reasonable purpose in connection with the performance of the obligations imposed on it by this Agreement or if necessary to meet its legal obligation to provide service to its customers.
- 2.3.3 Each Party shall be responsible for its own costs associated with following this article.

Article 3. Effective Date, Term, Termination, and Disconnection

3.1 Effective Date

This Agreement shall become effective upon execution by the Parties subject to acceptance by FERC (if applicable), or if filed unexecuted, upon the date specified by the FERC. The Transmission Owner shall promptly file this Agreement with the FERC upon execution, if required.

3.2 Term of Agreement

This Agreement shall become effective on the Effective Date and shall remain in effect for a period of ten years from the Effective Date or such other longer period as the Interconnection Customer may request and shall be automatically renewed for each successive one-year period thereafter, unless terminated earlier in accordance with article 3.3 of this Agreement.

3.3 Termination

No termination shall become effective until the Parties have complied with all Applicable Laws and Regulations applicable to such termination, including the filing with FERC of a notice of termination of this Agreement (if required), which notice has been accepted for filing by FERC.

- 3.3.1 The Interconnection Customer may terminate this Agreement at any time by giving the Transmission Owner 20 Business Days written notice.
- 3.3.2 Either Party may terminate this Agreement after Default pursuant to article 7.6.
- 3.3.3 Upon termination of this Agreement, the Small Generating Facility will be disconnected from the Transmission Owner's Transmission System. The termination of this Agreement shall not relieve either Party of its liabilities and obligations, owed or continuing at the time of the termination.
- 3.3.4 This provisions of this article shall survive termination or expiration of this Agreement.

3.4 Temporary Disconnection

Temporary disconnection shall continue only for so long as reasonably necessary under Good Utility Practice.

- 3.4.1 Emergency Conditions – “Emergency Condition” shall mean a condition or situation: (1) that in the judgment of the Party making the claim is imminently likely to endanger life or property; or (2) that, in the case of the Transmission Provider, is imminently likely (as determined in a non-discriminatory manner) to cause a material adverse effect on the security of, or damage to the Transmission System, the Transmission Owner's Interconnection Facilities or the Transmission Systems of others to which the Transmission System is directly connected; or (3) that, in the case of the Interconnection Customer, is imminently likely (as determined in a non-discriminatory manner) to cause a material adverse effect on the security of, or damage to, the Small Generating Facility or the Interconnection Customer's Interconnection Facilities. Under Emergency Conditions, the Transmission Owner may immediately suspend interconnection service and temporarily disconnect the Small Generating Facility. The Transmission Provider shall notify the Interconnection Customer promptly when it becomes aware of an Emergency Condition that may reasonably be expected to affect the Interconnection Customer's operation of the Small Generating Facility. The Interconnection Customer shall notify the Transmission Provider promptly when it becomes aware of an Emergency Condition that may reasonably be expected to affect the Transmission Owner's Transmission System or other Affected Systems. To the extent information is known, the notification shall describe the Emergency Condition, the extent of the damage or deficiency, the expected effect on the operation of both Parties' facilities and operations, its anticipated duration, and the necessary corrective action.

3.4.2 Routine Maintenance, Construction, and Repair

The Transmission Owner may interrupt interconnection service or curtail the output of the Small Generating Facility and temporarily disconnect the Small Generating Facility from the Transmission Owner's Transmission System when necessary for routine maintenance, construction, and repairs on the Transmission Provider's Transmission System. The Transmission Owner shall provide the Interconnection Customer with five Business Days notice prior to such interruption. The Transmission Owner shall use Reasonable Efforts to coordinate such reduction or temporary disconnection with the Interconnection Customer.

3.4.3 Forced Outages

During any forced outage, the Transmission Owner may suspend interconnection service to effect immediate repairs on the Transmission Owner's Transmission System. The Transmission Owner shall use Reasonable Efforts to provide the Interconnection Customer with prior notice. If prior notice is not given, the Transmission Owner shall, upon request, provide the Interconnection Customer written documentation after the fact explaining the circumstances of the disconnection.

3.4.4 Adverse Operating Effects

The Transmission Owner shall notify the Interconnection Customer as soon as practicable if, based on Good Utility Practice, operation of the Small Generating Facility may cause disruption or deterioration of service to other customers served from the same electric system, or if operating the Small Generating Facility could cause damage to the Transmission Owner's Transmission System or Affected Systems. Supporting documentation used to reach the decision to disconnect shall be provided to the Interconnection Customer upon request. If, after notice, the Interconnection Customer fails to remedy the adverse operating effect within a reasonable time, the Transmission Owner may disconnect the Small Generating Facility. The Transmission Owner shall provide the Interconnection Customer with five Business Day notice of such disconnection, unless the provisions of article 3.4.1 apply.

3.4.5 Modification of the Small Generating Facility

The Interconnection Customer must receive written authorization from the Transmission Owner before making any change to the Small Generating Facility that may have a material impact on the safety or reliability of the Transmission System. Such authorization shall not be unreasonably withheld. Modifications shall be done in accordance with Good Utility Practice. If the Interconnection Customer makes such modification without the Transmission Owner's prior

written authorization, the latter shall have the right to temporarily disconnect the Small Generating Facility.

3.4.6 Reconnection

The Parties shall cooperate with each other to restore the Small Generating Facility, Interconnection Facilities, and the Transmission Owner's Transmission System to their normal operating state as soon as reasonably practicable following a temporary disconnection.

Article 4. Cost Responsibility for Interconnection Facilities and Distribution Upgrades

None

4.1 Interconnection Facilities

4.1.1 The Interconnection Customer shall pay for the cost of the Interconnection Facilities itemized in Attachment 2 of this Agreement. The Transmission Owner shall provide a best estimate cost, including overheads, for the purchase and construction of its Interconnection Facilities and provide a detailed itemization of such costs. Costs associated with Interconnection Facilities may be shared with other entities that may benefit from such facilities by agreement of the Interconnection Customer, such other entities, and the Transmission Owner.

4.1.2 The Interconnection Customer shall be responsible for its share of all reasonable expenses, including overheads, associated with (1) owning, operating, maintaining, repairing, and replacing its own Interconnection Facilities, and (2) operating, maintaining, repairing, and replacing the Transmission Owner's Interconnection Facilities.

4.2 Distribution Upgrades

The Transmission owner shall design, procure, construct, install, and own the Distribution Upgrades described in Attachment 6 of this Agreement. If the Transmission Owner and the Interconnection Customer agree, the Interconnection Customer may construct Distribution Upgrades that are located on land owned by the Interconnection Customer. The actual cost of the Distribution Upgrades, including overheads, shall be directly assigned to the Interconnection Customer.

Article 5. Cost Responsibility for Network Upgrades None

5.1 Applicability

No portion of this article 5 shall apply unless the interconnection of the Small Generating Facility requires Network Upgrades.

5.2 Network Upgrades

The Transmission Owner shall design, procure, construct, install, and own the Network Upgrades described in Attachment 6 of this Agreement. If the Transmission Owner and the Interconnection Customer agree, the Interconnection Customer may construct Network Upgrades that are located on land owned by the Interconnection Customer. Unless the Transmission Owner elects to pay for Network Upgrades, the actual cost of the Network Upgrades, including overheads, shall be borne initially by the Interconnection Customer.

5.2.1 Repayment of Amounts Advanced for Network Upgrades

The Interconnection Customer shall be entitled to a cash repayment, equal to the total amount paid to the Transmission Owner for Network Upgrades, including any tax gross-up or other tax-related payments associated with the Network Upgrades, and not otherwise refunded to the Interconnection Customer, to be paid to the Interconnection Customer on a dollar-for-dollar basis for the non-usage sensitive portion of transmission charges, as payments are made under the Transmission Provider's Tariff for transmission services with respect to the Small Generating Facility. Any repayment shall include interest calculated in accordance with the methodology set forth in FERC's regulations at 18 C.F.R. §35.19a(a)(2)(iii) from the date of any payment for Network Upgrades through the date on which the Interconnection Customer receives a repayment of such payment pursuant to this subparagraph. The Interconnection Customer may assign such repayment rights to any person.

5.2.1.1 Notwithstanding the foregoing, the Interconnection Customer, the Transmission Owner, and Affected System operator may adopt any alternative payment schedule that is mutually agreeable so long as the Transmission Owner take one of the following actions no later than five years from the Commercial Operation Date: (1) return to the Interconnection Customer any amounts advanced for Network Upgrades not previously repaid, or (2) declare in writing that the Transmission Owner will continue to provide payments to the Interconnection Customer on a dollar-for-dollar basis for the non-usage sensitive portion of transmission charges, or develop an alternative schedule that is mutually agreeable and provides for the return of all amounts advanced for Network Upgrades not

previously repaid; however, full reimbursement shall not extend beyond twenty (20) years from the commercial operation date.

- 5.2.1.2 If the Small Generating Facility fails to achieve commercial operation, but it or another generating facility is later constructed and requires use of the Network Upgrades, the Transmission Owner shall at that time reimburse the Interconnection Customer for the amounts advanced for the Network Upgrades. Before any such reimbursement can occur, the Interconnection Customer, or the entity that ultimately constructs the generating facility, if different, is responsible for identifying the entity to which reimbursement must be made.

5.3 Special Provisions for Affected Systems

Unless the Transmission Owner provides, under this Agreement, for the repayment of amounts advanced to Affected System operator for Network Upgrades, the Interconnection Customer and Affected System operator shall enter into an agreement that provides for such repayment. The agreement shall specify the terms governing payments to be made by the Interconnection Customer to Affected System operator as well as the repayment by Affected System operator.

5.4 Rights Under Other Agreements

Notwithstanding any other provision of this Agreement, nothing herein shall be construed as relinquishing or foreclosing any rights, including but not limited to firm transmission rights, capacity rights, transmission congestion rights, or transmission credits, that the Interconnection Customer shall be entitled to, now or in the future, under any other agreement or tariff as a result of, or otherwise associated with, the transmission capacity, if any, created by the Network Upgrades, including the right to obtain cash reimbursements or transmission credits for transmission service that is not associated with the Small Generating Facility.

Article 6. Billing, Payment, Milestones, and Financial Security

6.1 Billing and Payment Procedures and Final Accounting

- 6.1.1 The Transmission Owner shall bill the Interconnection Customer for the design, engineering, construction, and procurement costs of Interconnection Facilities and Upgrades contemplated by this Agreement on a monthly basis, or as otherwise agreed by the Parties. The Interconnection Customer shall pay each bill within 30 calendar days of receipt, or as otherwise agreed to by the Parties.
- 6.1.2 Within three months of completing the construction and installation of the Transmission owner's Interconnection Facilities and/or Upgrades described in the Attachments to this Agreement, the Transmission Owner shall provide the

Interconnection Customer with a final accounting report of any difference between (1) the Interconnection Customer's cost responsibility for the actual cost of such facilities or Upgrades, and (2) the Interconnection Customer's previous aggregate payments to the Transmission Owner for such facilities or Upgrades. If the Interconnection Customer's cost responsibility exceeds its previous aggregate payments, the Transmission Owner shall invoice the Interconnection Customer for the amount due and the Interconnection Customer shall make payment to the Transmission Owner within 30 calendar days. If the Interconnection Customer's previous aggregate payments exceed its cost responsibility under this Agreement, the Transmission Owner shall refund to the Interconnection Customer an amount equal to the difference within 30 calendar days of the final accounting report.

6.2 Milestones None

The Parties shall agree on milestones for which each Party is responsible and list them in Attachment 4 of this Agreement. A Party's obligations under this provision may be extended by agreement. If a Party anticipates that it will be unable to meet a milestone for any reason other than a Force Majeure Event, it shall immediately notify the other Party of the reason(s) for not meeting the milestone and (1) propose the earliest reasonable alternate date by which it can attain this and future milestones, and (2) requesting appropriate amendments to Attachment 4. The Party affected by the failure to meet a milestone shall not unreasonably withhold agreement to such an amendment unless it will suffer significant uncompensated economic or operational harm from the delay, (2) attainment of the same milestone has previously been delayed, or (3) it has reason to believe that the delay in meeting the milestone is intentional or unwarranted notwithstanding the circumstances explained by the Party proposing the amendment.

6.3 Financial Security Arrangements

At least 20 Business Days prior to the commencement of the design, procurement, installation, or construction of a discrete portion of the Transmission Provider's Interconnection Facilities and Upgrades, the Interconnection Customer shall provide the Transmission Provider, at the Interconnection Customer's option, a guarantee, a surety bond, letter of credit or other form of security that is reasonably acceptable to the Transmission Provider and is consistent with the Uniform Commercial Code of the jurisdiction where the Point of Interconnection is located. Such security for payment shall be in an amount sufficient to cover the costs for constructing, designing, procuring, and installing the applicable portion of the Transmission Provider's Interconnection Facilities and Upgrades and shall be reduced on a dollar-for-dollar basis for payments made to the Transmission Provider under this Agreement during its term. In addition:

- 6.3.1 The guarantee must be made by an entity that meets the creditworthiness requirements of the Transmission Provider, and contain terms and conditions that guarantee payment of any amount that may be due from the Interconnection Customer, up to an agreed-to maximum amount.

- 6.3.2 The letter of credit or surety bond must be issued by a financial institution or insured reasonably acceptable to the Transmission Provider and must specify a reasonable expiration date.

Article 7. Assignment, Liability, Indemnity, Force Majeure, Consequential Damages, and Default

7.1 Assignment

This Agreement may be assigned by either Party upon 15 Business Days prior written notice and opportunity to object by the other Party; provided that:

- 7.1.1 Either Party may assign this Agreement without the consent of the other Party to any affiliate of the assigning Party with an equal or greater credit rating and with the legal authority and operational ability to satisfy the obligations of the assigning Party under this Agreement;
- 7.1.2 The Interconnection Customer shall have the right to assign this Agreement, without the consent of the Transmission Owner, for collateral security purposes to aid in providing financing for the Small Generating Facility, provided that the Interconnection Customer will promptly notify the Transmission Owner of any such assignment.
- 7.1.3 Any attempted assignment that violates this article is void and ineffective. Assignment shall not relieve a Party of its obligations, nor shall a Party's obligations be enlarged, in whole or in part, by reason thereof. An assignee is responsible for meeting the same financial, credit, and insurance obligations as the Interconnection Customer. Where required, consent to assignment will not be unreasonably withheld, conditioned or delayed.

7.2 Limitation of Liability

Each Party's liability to the other Party for any loss, cost, claim, injury, liability, or expense, including reasonable attorney's fees, relating to or arising from any act or omission in its performance of this Agreement, shall be limited to the amount of direct damage actually incurred. In no event shall either Party be liable to the other Party for any indirect, special, consequential, or punitive damages, except as authorized by this Agreement.

7.3 Indemnity

- 7.3.1 This provision protects each Party from liability incurred to third parties as a result of carrying out the provisions of this Agreement. Liability under this provision is exempt from the general limitations on liability found in article 7.2.

- 7.3.2 The Parties shall at all times indemnify, defend, and hold the other Party harmless from, any and all damages, losses, claims, including claims and actions relating to injury to or death of any person or damage to property, demand, suits, recoveries, costs and expenses, court costs, attorney fees, and all other obligations by or to third parties, arising out of or resulting from the other Party's action or failure to meet its obligations under this Agreement on behalf of the indemnifying Party, except in cases of gross negligence or intentional wrongdoing by the indemnified Party.
- 7.3.3 If an indemnified person is entitled to indemnification under this article as a result of a claim by a third party, and the indemnifying Party fails, after notice and reasonable opportunity to proceed under this article, to assume the defense of such claim, such indemnified person may at the expense of the indemnifying Party contest, settle or consent to the entry of any judgment with respect to, or pay in full, such claim.
- 7.3.4 If an indemnifying party is obligated to indemnify and hold any indemnified person harmless under this article, the amount owing to the indemnified person shall be the amount of such indemnified person's actual loss, net of any insurance or other recovery.
- 7.3.5 Promptly after receipt by an indemnified person of any claim or notice of the commencement of any action or administrative or legal proceeding or investigation as to which the indemnity provided for in this article may apply, the indemnified person shall notify the indemnifying party of such fact. Any failure of or delay in such notification shall not affect a Party's indemnification obligation unless such failure or delay is materially prejudicial to the indemnifying party.

7.4 Consequential Damages

Other than as expressly provided for in this Agreement, neither Party shall be liable under any provision of this Agreement for any losses, damages, costs or expenses for any special, indirect, incidental, consequential, or punitive damages, including but not limited to loss of profit or revenue, loss of the use of equipment, cost of capital, cost of temporary equipment or services, whether based in whole or in part in contract, in tort, including negligence, strict liability, or any other theory of liability; provided, however, that damages for which a Party may be liable to the other Party under another agreement will not be considered to be special, indirect, incidental, or consequential damages hereunder.

7.5 Force Majeure

- 7.5.1 As used in this article, a Force Majeure Event shall mean "any act of God, labor disturbance, act of the public enemy, war, insurrection, riot, fire, storm or flood, explosion, breakage or accident to machinery or equipment, any order, regulation

or restriction imposed by governmental, military or lawfully established civilian authorities, or any other cause beyond a Party's control. A Force Majeure Event does not include any act of negligence or intentional wrongdoing.”

7.5.2 If a Force Majeure Event prevents a Party from fulfilling any obligations under this Agreement, the Party affected by the Force Majeure Event (Affected Party) shall promptly notify the other Party, either in writing or via the telephone, of the existence of the Force Majeure Event. The notification must specify in reasonable detail the circumstances of the Force Majeure Event, its expected duration, and the steps that the Affected Party is taking to mitigate the effects of the event on its performance. The Affected Party shall keep the other Party informed on a continuing basis of developments relating to the Force Majeure Event until the event ends. The Affected Party will be entitled to suspend or modify its performance of obligations under this Agreement (other than the obligation to make payments) only to the extent that the effect of the Force Majeure Event cannot be mitigated by the use of Reasonable Efforts. The Affected Party will use Reasonable Efforts to resume its performance as soon as possible.

7.6 Default

7.6.1 No Default shall exist where such failure to discharge an obligation (other than the payment of money) is the result of a Force Majeure Event as defined in this Agreement or the result of an act or omission of the other Party. Upon a Default, the non-defaulting Party shall give written notice of such Default to the defaulting Party. Except as provided in article 7.6.2, the defaulting Party shall have 60 calendar days from receipt of the Default notice within which to cure such Default; provided however, if such Default is not capable of cure within 60 calendar days the defaulting Party shall commence such cure within 20 calendar days after notice and continuously and diligently complete such cure within six months from receipt of the Default notice; and, if cured within such time, the Default specified in such notice shall cease to exist.

7.6.2 If a Default is not cured as provided in this article, or if a Default is not capable of being cured within the period provided for herein, the non-defaulting Party shall have the right to terminate this Agreement by written notice at any time until cure occurs, and be relieved of any further obligation hereunder and, whether or not that Party terminates this Agreement, to recover from the defaulting Party all amounts due hereunder, plus all other damages and remedies to which it is entitled at law or in equity. The provisions of this article will survive termination of this Agreement.

Article 8. Insurance

8.1 The Interconnection Customer shall, at its own expense, maintain in force general

liability insurance without any exclusion for liabilities related to the interconnection undertaken pursuant to this Agreement. The amount of such insurance shall be sufficient to insure against all reasonably foreseeable direct liabilities given the size and nature of the generating equipment being interconnected, the interconnection itself, and the characteristics of the system to which the interconnection is made. The Interconnection Customer shall obtain additional insurance only if necessary as a function of owning and operating a generating facility. Such insurance shall be obtained from an insurance provider authorized to do business in the State where the interconnection is located. Certification that such insurance is in effect shall be provided upon request of the Transmission Provider, except that the Interconnection Customer of sufficient credit-worthiness may propose to self-insure for such liability, and such a proposal shall not be unreasonably rejected.

- 8.2 The Transmission Owner agrees to maintain general liability insurance or self-insurance consistent with the Transmission Owner's commercial practice. Such insurance or self-insurance shall not exclude coverage for the Transmission Owner's liabilities undertaken pursuant to this Agreement.
- 8.3 The Parties further agree to notify each other whenever an accident or incident occurs resulting in any injuries or damages that are included within the scope of coverage of such insurance, whether or not such coverage is sought.

Article 9. Confidentiality

- 9.1 Confidential Information shall mean any confidential and/or proprietary information provided by one Party to the other Party that is clearly marked or otherwise designated "Confidential." For purposes of this Agreement all design, operating specifications, and metering data provided by the Interconnection Customer shall be deemed Confidential Information regardless of whether it is clearly marked or otherwise designated as such.
- 9.2 Confidential Information does not include information previously in the public domain, required to be publicly submitted or divulged by Governmental Authorities (after notice to the other Party and after exhausting any opportunity to oppose such publication or release), or necessary to be divulged in an action to enforce this Agreement. Each party receiving Confidential Information shall hold such information in confidence and shall not disclose it to any third party nor to the public without prior written authorization from the Party providing that information, except to fulfill obligations under this Agreement, or to fulfill legal or regulatory requirements.
 - 9.2.1 Each Party shall employ at least the same standard of care to protect Confidential Information obtained from the other Party as it employs to protect its own Confidential Information.
 - 9.2.2 Each Party is entitled to equitable relief, by injunction or otherwise, to enforce its rights under this provision to prevent the release of Confidential Information

without bond or proof of damages, and may seek other remedies available at law or in equity for breach of this provision.

- 9.3 Notwithstanding anything in this article to the contrary, and pursuant to 81 CFR § 1b.20, if FERC, during the course of an investigation or otherwise, requests information from one of the Parties that is otherwise required to be maintained in confidence pursuant to this Agreement, the Party shall provide the requested information to FERC, within the time provided for in the request for information. In providing the information to FERC, the Party may, consistent with 18 CFR § 388.112, request that the information be treated as confidential and non-public by FERC and that the information be withheld from public disclosure. Parties are prohibited from notifying the other Party to this Agreement prior to the release of the Confidential Information to FERC. The Party shall notify the other Party to this Agreement when it is notified by FERC that a request to release Confidential Information has been received by FERC, at which time either of the Parties may respond before such information would be made public, pursuant to 18 CFR § 388.112. Requests from a state regulatory body conducting a confidential investigation shall be treated in a similar manner if consistent with the applicable state rules and regulations.

Article 10. Disputes

- 10.1 The Parties agree to attempt to resolve all disputes arising out of the interconnection process according to the provisions of this article.
- 10.2 In the event of a dispute, either Party shall provide the other Party with a written Notice of Dispute. Such Notice shall describe in detail the nature of the dispute.
- 10.3 If the dispute has not been resolved within two Business Days after receipt of the Notice, either Party may contact FERC's Dispute Resolution Service (DRS) for assistance in resolving the dispute.
- 10.4 The DRS will assist the Parties in either resolving their dispute or in selecting an appropriate dispute resolution venue (e.g. mediation, settlement judge, early neutral evaluation, or technical expert) to assist the Parties in resolving their dispute. DRS can be reached at 1-877-33-2237 or via the internet at <http://www.ferc.gov/legal/adr.asp>.
- 10.5 Each Party agrees to conduct all negotiations in good faith and will be responsible for one-half of any costs paid to neutral third-parties.
- 10.6 If neither Party elects to seek assistance from the DRS, or if the attempted dispute resolution fails, then either Party may exercise whatever rights and remedies it may have in equity or law consistent with the terms of this Agreement.

Article 11. Taxes

- 11.1 The Parties agree to follow all applicable tax laws and regulations, consistent with FERC policy and Internal Revenue Service requirements.

- 11.2 Each Party shall cooperate with the other to maintain the other Party's tax status. Nothing in this Agreement is intended to adversely affect the Transmission Owner's tax exempt status with respect to the issuance of bonds including, but not limited to, local furnishing bond.

Article 12. Miscellaneous

12.1 Governing Law, Regulatory Authority, and Rules

The validity, interpretation and enforcement of this Agreement and each of its provision shall be governed by law of the state of New York (where the Point of Interconnection is located), without regard to its conflicts of law principles. This Agreement is subject to all Applicable Laws and Regulations. Each party expressly reserves the right to seek changes in, appeal, or otherwise contest any laws, orders, or regulations of a Governmental Authority.

12.2 Amendment

The Parties may amend this Agreement by a written instrument duly executed by both Parties.

12.3 No Third-Party Beneficiaries

This Agreement is not intended to and does not create rights, remedies, or benefits of any character whatsoever in favor of any persons, corporations, associations, or entities other than the Parties, and the obligations herein assumed are solely for the use and benefit of the Parties, their successors in interest and where permitted, their assigns.

12.4 Waiver

12.4.1 The failure of a Party to this Agreement to insist, on any occasion, upon strict performance of any provision of this Agreement will not considered a waiver of any obligation, right, or duty of, or imposed upon, such Party.

12.4.2 Any waiver at any time by either Party of its rights with respect to this Agreement shall not be deemed a continuing waiver or a waiver with respect to any other failure to comply with any other obligation, right, duty to this Agreement. Termination or default of this Agreement for any reason by Interconnection Customer shall not constitute a waiver of the Interconnection Customer's legal rights to obtain an interconnection from the Transmission Owner. Any waiver of this Agreement shall, if requested, be provided in writing.

12.5 Entire Agreement

This Agreement, including all Attachments, constitutes the entire agreement between the Parties with reference to the subject matter hereof, and supersedes all prior and contemporaneous understanding or agreements, oral or written, between Parties with respect to the subject matter of this Agreement. There are no other agreements, representations, warranties or covenants which constitute any part of the consideration for, or any condition to, either Party's compliance with its obligations under the Agreement.

12.6 Multiple Counterparts

This Agreement may be executed in two or more counterparts, each of which is deemed an original but all constitute one and the same instrument.

12.7 No Partnership

This Agreement shall not be interpreted or construed to create an association, joint venture, agency relationship, or partnership between the Parties or to impose any partnership obligation or partnership liability upon either Party. Neither Party shall have any right, power or authority to enter into any agreement or undertaking for, or act on behalf of, or to act as or be an agent or representative of, or to otherwise bind, the other Party.

12.8 Severability

If any provision or portion of this Agreement shall for any reason be held or adjudged to be invalid or illegal or unenforceable by any court of competent jurisdiction or other Governmental Authority, (1) such portion or provision shall be deemed separate and independent, (2) the Parties shall negotiate in good faith to restore insofar as practicable the benefits to each Party that were affected by such ruling, and (3) the remainder of this Agreement shall remain in full force and effect.

12.9 Security Arrangements

Infrastructure security of electric system equipment and operations and control hardware and software is essential to ensure day-to-day reliability and operational security. FERC expects all Transmission Providers, Transmission Owners, market participants and Interconnection Customers interconnected to electric system to comply with the recommendations offered by the President's Critical Infrastructure Protection Board and, eventually, best practice recommendations from the electric reliability authority. All public utilities are expected to meet basic standards for system infrastructure and operational security, including physical, operational, and cyber-security practices.

12.10 Environmental Release

Each Party shall notify the other Party, first orally and then in writing, of the release of any hazardous substances, any asbestos or lead abatement activities, or any type of

remediation activities related to the Small Generating Facilities or Interconnection Facilities, each of which may reasonably be expected to affect the other Party. The notifying Party shall (1) provide the notice as soon as practicable, provided such Party make a good faith effort to provide the notice no later than 24 hours after such Party becomes aware of the occurrence and (2) promptly furnish to the other Party copies of any publicly available reports filed with any governmental authorities addressing such events.

12.11 Subcontractors

Nothing in this Agreement shall prevent a Party from utilizing the services of any subcontractor as it deems appropriate to perform its obligations under this Agreement; provided, however, that each Party shall require its subcontractors to comply with all applicable terms and conditions of this Agreement in providing such services and each Party shall remain primarily liable to the other Party for the performance of such subcontractor.

12.11.1 The creation of any subcontract relationship shall not relieve the hiring Party of any of its obligations under this Agreement. The hiring Party shall be fully responsible to the other Party for the acts or omission of any subcontractor the hiring Party hires as if no subcontract had been made; provided, however, that in no event shall the Transmission Owner be liable for the actions or inaction of the Interconnection Customer or its subcontractors with respect to obligation imposed by this Agreement upon the hiring Party shall be equally binding upon, and shall be construed as having application to, any subcontractor of such Party.

12.11.2 The obligation under this article will not be limited in any way by any limitation of subcontractor's insurance.

12.12 Reservation of Rights

The Transmission Owner shall have the right to make a unilateral filing with FERC to modify this Agreement with respect to any rates, terms and conditions, charges, classification of service, rule or regulation under section 205 or any other applicable provision of the Federal Power Act and FERC's rules and regulations thereunder, and the Interconnection Customer shall have the right to make a unilateral filing with FERC to modify this Agreement under an applicable provision of the Federal Power Act and FERC's rules and regulations; provided that each Party shall have the right to protest any such filing by the other Party and to participate fully in any proceeding before FERC in which such modifications may be considered. Nothing in this Agreement shall limited the right of the Parties or of FERC under sections 205 or 206 of the Federal Power Act and FERC's rules and regulations, except to the extent that the Parties otherwise agree as provided herein.

Article 13. Notices

13.1 General

Unless otherwise provided in this Agreement, any written notice, demand, or request required or authorized in connection with this Agreement (“Notice”) shall be deemed properly given if delivered in person, delivered by recognized national carrier service, or sent by first class mail, postage prepaid, to the person specified below:

If to the Interconnection Customer:

Interconnection Customer: WM Renewable Energy, L.L.C.
Attention: Randy Beck
Address: 1001 Fannin, Suite 4000
City: Houston State: TX Zip: 77002
Phone: 713-265-1672 Fax: 713-287-2423

If to the Transmission Owner:

Transmission Owner: Niagara Mohawk Power Corporation d/b/a nationalgrid
Attention: Director, Transmission Commercial Services
Address: 300 Erie Boulevard West
City: Syracuse State: NY Zip: 13202
Phone: (781) 907-2422 Fax: (781) 907-5707

13.2 Billing and Payment

Billings and payments shall be sent to the addresses set out below:

If to the Interconnection Customer:

Interconnection Customer: WM Renewable Energy, L.L.C.
Attention: Todd Roberts - Controller
Address: 1001 Fannin, Suite 4000
City: Houston State: TX Zip: 77002
Phone: 713-328-7343 Fax: 713-287-2423

If to the Transmission Owner:

Transmission Owner: Niagara Mohawk Power Corporation d/b/a nationalgrid ____
Attention: Transmission Billing _____
Address: West Wing, 2nd Floor
40 Sylvan Road _____
City: Waltham State: MA Zip: 02451 _____
Phone: (781) 907-2221 Fax: (781) 907-5707 _____

13.3 Alternative Form of Notice

Any notice or request required or permitted to be given by either Party to the other and not required by this Agreement to be given in writing may be so given by telephone, facsimile or e-mail to the telephone numbers and e-mail addresses set out below:

If to the Interconnection Customer:

Interconnection Customer: WM Renewable Energy, L.L.C. ____
Attention: Randy Beck ____
Address: 1001 Fannin, Suite 4000 _____
City: Houston State: TX Zip: 77002 _____
Phone: 713-265-1672 Fax: 713-287-2423 ____

If to the Transmission Owner:

Transmission Owner: Niagara Mohawk Power Corporation d/b/a nationalgrid
Attention: Transmission Account Manager _____
Address: 300 Erie Boulevard West _____
City: Syracuse State: NY Zip: 13202 _____
Phone: (315) 428-5047 Fax: (315) 428-5114 ____

13.4 Designated Operating Representative

The Parties may also designate operating representatives to conduct the communications which may be necessary or convenient for the administration of this Agreement. This person will also serve as the point of contact with respect to operations and maintenance of the Party's facilities.

If to the Interconnection Customer:

Interconnection Customer: WM Renewable Energy, L.L.C. ____
Attention: Randy Beck ____
Address: 1001 Fannin, Suite 4000 _____
City: Houston State: TX Zip: 77002 _____
Phone: 713-265-1672 Fax: 713-287-2423 ____

If to the Transmission Owner:

Transmission Owner: Niagara Mohawk Power Corporation d/b/a nationalgrid
Attention: Transmission Account Manager
Address: 300 Erie Boulevard West
City: Syracuse State: NY Zip: 132042
Phone: (315) 428-5047 Fax: (315) 428-5114

13.5 Changes to the Notice Information

Either Party may change this information by giving five Business Days written notice prior to the effective date of this change.

Article 14. Signatures

IN WITNESS WHEREOF, the Parties have caused this Agreement to be executed by their respective duly authorized representative.

For the Transmission Owner

Name: Will J. Mal

Title: Authorized Representative

Date: 6/1/11

For the Interconnection Customer

Name: David Cooper

Title: Vice President

Date: 6-23-11

Attachment 1

Glossary of Terms

Affected System – An electric system other than the Transmission owner’s Transmission System that may be affected by the proposed interconnection.

Applicable Laws and Regulations – All duly promulgated applicable federal, state and local laws, regulations, rules, ordinances, codes, decrees, judgments, directives, or judicial or administrative orders, permits and other duly authorized actions of any Governmental Authority.

Business Day – Monday through Friday, excluding Federal Holidays.

Default – The failure of a breaching Party to cure its Breach under the Small Generator Interconnection Agreement.

Distribution System – The Transmission Owner’s facilities and equipment used to transmit electricity to ultimate usage points such as homes and industries directly from nearby generators or from interchanges with higher voltage transmission networks which transport bulk power over longer distances. The voltage levels at which Distribution Systems operate differ among areas.

Distribution Upgrades – The additions, modifications, and upgrades to the Transmission Owner’s Distribution System at or beyond the Point of Interconnection to facilitate interconnection of the Small Generating Facility and render the transmission service necessary to effect the Interconnection Customer’s wholesale sale of electricity in interstate commerce. Distribution Upgrades do not include Interconnection Facilities.

Good Utility Practice – Any of the practices, methods and acts engaged in or approved by a significant portion of the electric industry during the relevant time period, or any of the practices, methods and acts which, in the exercise of reasonable judgment in light of the facts known at the time the decision was made, could have been expected to accomplish the desired result at a reasonable cost consistent with good business practices, reliability, safety and expedition. Good Utility Practice is not intended to be limited to the optimum practice, method, or act to the exclusion of all others, but rather to be acceptable practices, methods, or acts generally accepted in the region.

Governmental Authority – Any federal, state, local or other governmental regulatory or administrative agency, court, commission, department, board, or other governmental subdivision, legislature, rulemaking board, tribunal, or other governmental authority having jurisdiction over the Parties, their respective facilities, or the respective services they provide, and exercising or entitled to exercise any administrative, executive, police, or taxing authority or power; provided, however, that such term does not include the Interconnection Customer, the Interconnection Provider, or any Affiliate thereof.

Interconnection Customer – Any entity, including the Transmission Provider, the Transmission Owner or any of the affiliates or subsidiaries of either, that proposes to interconnect its Small Generating Facility with the Transmission Owner’s Transmission System.

Interconnection Facilities – The Transmission Owner’s Interconnection Facilities and the Interconnection Customer’s Interconnection Facilities. Collectively, Interconnection Facilities include all facilities and equipment between the Small Generating Facility and the Point of Interconnection, including any modification, additions or upgrades that are necessary to physically and electrically interconnect the Small Generating Facility to the Transmission Owner’s Transmission System. Interconnection Facilities are sole use facilities and shall not include Distribution Upgrades or Network Upgrades.

Interconnection Request – The Interconnection Customer’s request, in accordance with the Tariff, to interconnect a new Small Generating Facility, or to increase the capacity of, or make a Material Modification to the operating characteristics of, an existing Small Generating Facility that is interconnected with the Transmission Owner’s Transmission System.

Material Modification – A modification that has a material impact on the cost or timing of any Interconnection Request with a later queue priority date.

Network Upgrades – Additions, modifications, and upgrades to the Transmission Owner’s Transmission System required at or beyond the point at which the Small Generating Facility interconnects with the Transmission Owner’s Transmission System to accommodate the interconnection of the Small Generating Facility with the Transmission Owner’s Transmission System. Network Upgrades do not include Distribution Upgrades.

Operating Requirements – Any operating and technical requirements that may be applicable due to Regional Transmission Organization, Independent System Operator, control area, or the Transmission Owner’s requirements, including those set forth in the Small Generator Interconnection Agreement.

Party or Parties as applicable– The Transmission Provider, Transmission Owner, Interconnection Customer or any combination of the above.

Point of Interconnection – The point where the Interconnection Facilities connect with the Transmission Owner’s Transmission System.

Reasonable Efforts – With respect to an action required to be attempted or taken by a Party under the Small Generator Interconnection Agreement, efforts that are timely and consistent with Good Utility Practice and are otherwise substantially equivalent to those a Party would use to protect its own interests.

Small Generating Facility – The Interconnection Customer’s device for the production of electricity identified in the Interconnection Request, but shall not include the Interconnection Customer’s Interconnection Facilities.

Tariff – The Transmission Provider’s Tariff through which open access transmission service and Interconnection Service are offered, as filed with the FERC, and as amended or supplemented from time to time, or any successor tariff.

Transmission Owner – The entity that owns, leases or otherwise possesses an interest in the portion of the Transmission System at the Point of Interconnection and may be a Party to the Small Generator Interconnection Agreement to the extent necessary.

Transmission Provider – The public utility (or its designated agent) that controls, or operates transmission or distribution facilities used for the transmission of electricity in interstate commerce and provides transmission service under the Tariff. .

Transmission System – The facilities controlled or operated by the Transmission Provider or the Transmission Owner that are used to provide transmission service under the Tariff.

Upgrades – The required additions and modifications to the Transmission Provider’s Transmission System at or beyond the Point of Interconnection. Upgrades may be Network Upgrades or Distribution Upgrades. Upgrades do not include Interconnection Facilities.

Attachment 2

**Description and Costs of the Small Generating Facility,
Interconnection Facilities, and Metering Equipment**

The Interconnection Customer shall continue to own and maintain its Interconnection Facilities with Niagara Mohawk's Transmission System, including the generator output leads, the generator step-up transformer and associated equipment up to and including the substation take-off structure and disconnect switch No. 39, excluding Niagara Mohawk's metering equipment.

The Transmission Owner's Interconnection Facilities shall consist of Niagara Mohawk's 0.77 mile 34.5 kV transmission line, including the associated right of way, from the jaw side of disconnect switch No. 39 to Niagara Mohawk's interconnection to the Caledonia - Golah No. 213 line.

Delivery Point shall be the interconnection to the Caledonia - Golah No. 213 line.

Interconnection Point shall be at the jaw side of disconnect switch No. 39.

One-line Diagram Depicting the Small Generating Facility, Interconnection Facilities, Metering Equipment, and Upgrades

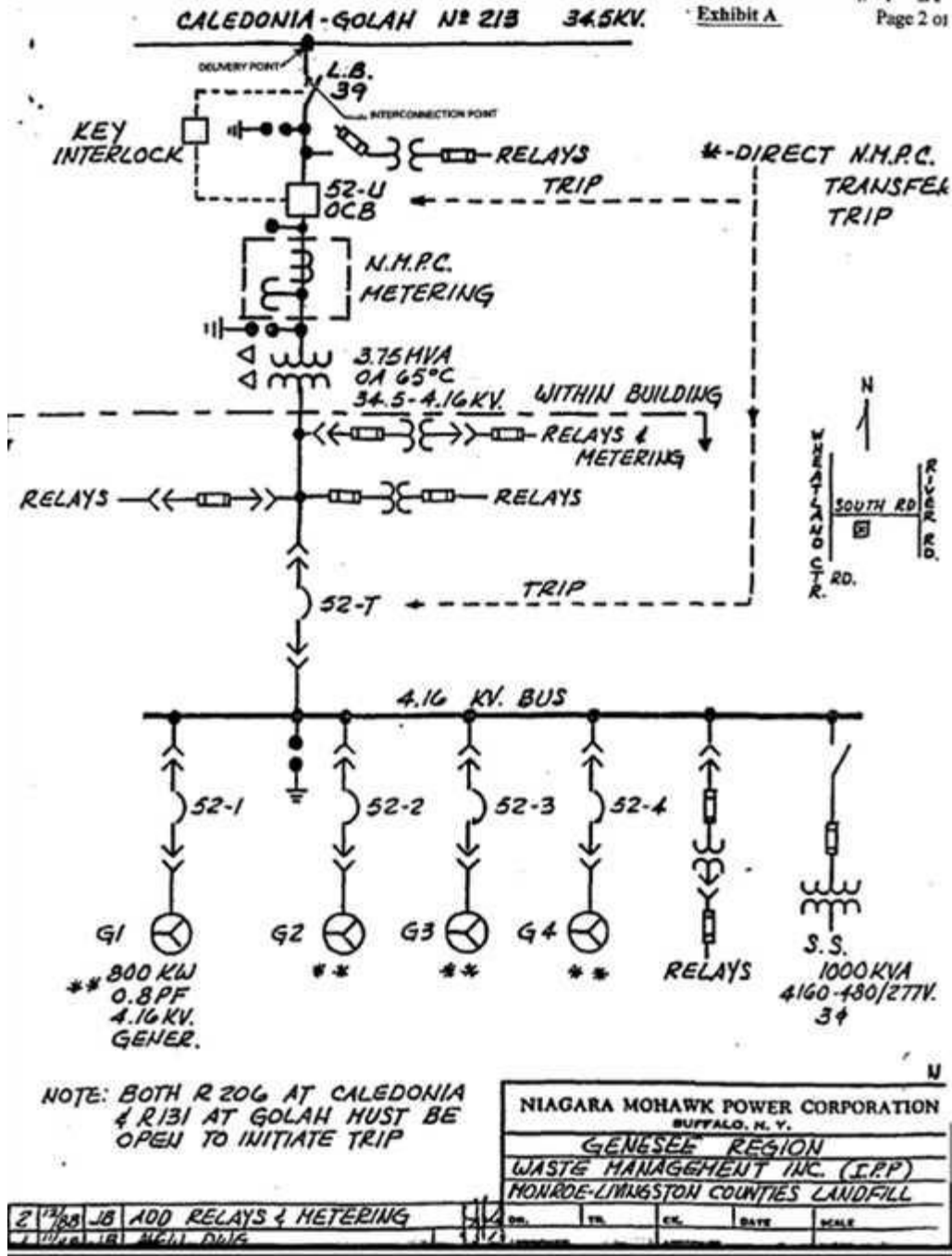

Attachment 4

Milestones

N/A

Attachment 5

**Additional Operating Requirements for the Transmission Owner's
Transmission System and Affected Systems Needed to Support
the Interconnection Customer's Needs**

The Interconnection Customer agrees that the operation of the Small Generating Facility and the Interconnection Customer's Interconnection Facilities must meet or exceed the standards of Good Utility Practice, which shall include, but not be limited to, NERC, NPCC, NYSRC and NYISO criteria, rules and standards, as they may be amended from time to time, including the rules, guidelines and criteria of any successor organizations to the foregoing entities.

The Small Generating Facility and the Interconnection Customer's Interconnection Facilities shall meet all requirements of Niagara Mohawk's Electric System Bulletin No. 756; provided, however, that in the event of a conflict between the requirements, rules and regulations of the NYISO and the requirements of Electric System Bulletin No. 756, the requirements, rules and regulations of the NYISO shall govern.

Attachment 6

**Transmission Owner's Description of its Upgrades
And Best Estimate of Upgrade Costs**

N/A