

FERC rendition of the electronically filed tariff records in Docket No. [include if docket no. exists]

Filing Data:

CID: C000038

Filing Title: Niagara Mohawk Power Corporation and the Village of Ilion Interconnection Agreement 2416

Company Filing Identifier: 971

Type of Filing Code: 10

Associated Filing Identifier: [if applicable]

Tariff Title: NYISO Agreements

Tariff ID: 58

Payment Confirmation: N

Suspension Motion:

Tariff Record Data:

Record Content Description: Service Agreement No. 2416

Tariff Record Title: NiMo and Ilion Interconnection Agreement 2416

Record Version Number: 0.0.0

Option Code: A

Tariff Record ID: 226

Tariff Record Collation Value: 8083000

Tariff Record Parent Identifier: 2

Proposed Date: 2018-03-28

Priority Order: 500

Record Change Type: New

Record Content Type: 2

Associated Filing Identifier: [Source - if applicable]

NYISO OATT SERVICE AGREEMENT No. 2416

INTERCONNECTION AGREEMENT

BETWEEN

NIAGARA MOHAWK POWER CORPORATION d/b/a NATIONAL GRID

AND

VILLAGE OF ILION

EXECUTION COPY

ARTICLE I DEFINITIONS 1

ARTICLE II AGREEMENT TO INTERCONNECT DESCRIPTION OF INTERCONNECTION FACILITIES 12

ARTICLE III REPRESENTATIONS AND WARRANTIES OF PARTIES 15

ARTICLE IV INTERCONNECTION STUDY 17

ARTICLE V OPERATION, MAINTENANCE, AND MODIFICATION OF FACILITIES 25

ARTICLE VI POWER DELIVERIES 32

ARTICLE VIII INSURANCE PROVISIONS 40

ARTICLE IX COMPLIANCE WITH LAWS 43

ARTICLE X COST PAYMENTS 46

ARTICLE XI NOTICES 52

ARTICLE XII TERM AND TERMINATION 55

ARTICLE XIII FORCE MAJEURE 57

ARTICLE XIV INDEMNIFICATION 58

ARTICLE XV RELATIONSHIP OF THE PARTIES 60

ARTICLE XVI THIRD PARTY BENEFICIARY/ASSIGNMENT 60

ARTICLE XVII APPROVAL 63

ARTICLE XVIII WAIVER 63

ARTICLE XIX AMENDMENT AND MODIFICATION 64

ARTICLE XX GOVERNING LAW 65

ARTICLE XXI DISPUTE RESOLUTION 65

ARTICLE XXII LIMITATION OF LIABILITY 66

ARTICLE XXIII CONFIDENTIALITY 67

ARTICLE XXIV SEVERABILITY 73

ARTICLE XXV HEADINGS 74

ARTICLE XXVI INFORMATION ACCESS AND AUDIT RIGHTS 74

ARTICLE XXVII. SUBCONTRACTORS 76

ARTICLE XXVIII COMPLIANCE WITH GOOD UTILITY PRACTICE 77

ARTICLE XXIX COUNTERPARTS..... 77

ARTICLE XXX MISCELLANEOUS 77

This INTERCONNECTION AGREEMENT (the “Agreement”) is made as of March __, 2018, between Niagara Mohawk Power Corporation d/b/a National Grid (“National Grid”), a New York Corporation, and the Village of Ilion (“Municipal”), (Collectively Municipal and National Grid may be referred to as the “Parties” or individually, as a “Party”).

WHEREAS, the Municipal owns and operates an existing load serving municipal electric system, which is connected to the National Grid Transmission System in New York State, and

WHEREAS, Municipal and National Grid have agreed to enter into this Interconnection Agreement for the purpose of documenting certain terms and conditions related to the interconnection of the systems and the manner by which National Grid and Municipal will coordinate to ensure the ongoing reliability of the New York State Transmission System.

NOW THEREFORE, in consideration of the mutual representations, covenants and agreements set forth herein, the Parties to this Agreement agree as follows:

ARTICLE I DEFINITIONS

The following terms, when used herein with initial capitalization, shall have the meanings specified in this Article I. Terms used in this Agreement with initial capitalization that are not defined in this Article I shall have the meanings specified in Section 1.0 or Attachment S of the NYISO OATT.

“**Affiliate**” shall mean, with respect to a person or entity, any individual, corporation, partnership, firm, joint venture, association, joint-stock company, trust or unincorporated organization, directly or indirectly controlling, controlled by, or under

common control with, such person or entity. The term “control” shall mean the possession, directly or indirectly, of the power to direct the management or policies of a person or an entity. A voting interest of ten percent or more shall create a rebuttable presumption of control.

“**Agreement**” shall mean this Interconnection Agreement between National Grid and Municipal, including all exhibits hereto, as the same may be amended, supplemented, revised, altered, changed, or restated in accordance with its terms.

“**Ancillary Services**” shall mean those services that are necessary to support the transmission of Capacity and Energy from resources to Loads while maintaining reliable operation of the New York State Transmission System in accordance with Good Utility Practice.

“**Applicable Laws and Regulations**” shall mean all duly promulgated applicable federal, state and local laws, regulations, rules, ordinances, codes, decrees, judgments, directives, or judicial or administrative orders, permits and other duly authorized actions of any Governmental Authority, including but not limited to laws or regulations relating to pollution or protection of the environment or natural resources.

“**Applicable Reliability Councils**” shall mean the North American Electric Reliability Corporation, the Northeast Power Coordinating Council, the New York State Reliability Council, and related and successor organizations.

“Applicable Reliability Standards” shall mean the requirements and guidelines of the
Applicable Reliability Councils, and the Transmission District to which the Municipal

System is directly interconnected, as those requirements and guidelines are amended and modified and in effect from time to time; provided that no Party shall waive its right to challenge the applicability or validity of any requirement or guideline as applied to it in the context of this Agreement.

“**Authority**” shall mean a Public Utility Authority formed per the New York State Public Authority Law as a Public Benefit Corporation.

“**Breach**” shall mean the failure of a Party to perform or observe any material term or condition of this Agreement.

“**Bulletin No. 752**” or “**ESB 752**” means that certain National Grid document designated as Electric System Bulletin No. 752 attached hereto as Exhibit C, as such Bulletin may be amended or superseded from time to time without amendment to this Agreement.

“**Business Day**” shall mean Monday through Friday, excluding federal holidays.

“**Calendar Day**” shall mean any day including Saturday, Sunday or a federal holiday.

“**Confidential Information**” means any plan, specification, pattern, procedure, design, device, list, concept, policy or compilation relating to the present or planned business of a Party which has not been released publicly by its authorized representatives and which has been designated as "Confidential" by the Party asserting a claim of confidentiality, whether

such Confidential Information is conveyed orally, electronically, in writing, through inspection, or otherwise. Confidential Information as used herein also includes

Confidential Information supplied by any Party to another Party prior to the execution of this Agreement, and such Confidential Information shall be considered in the same manner and be subject to the same treatment as the Confidential Information made available after the execution of this Agreement. Confidential Information shall also include Confidential Information observed by any Party while visiting the premises of another Party.

“**Effective Date**” shall mean the date on which this Agreement becomes effective upon execution by the Parties, subject to acceptance by the Commission.

“**Electricity**” shall mean electric capacity as measured in MW or kW, energy as measured in MWh or kWh, and/or ancillary services.

“**Emergency Condition**” shall mean a condition or situation which is deemed imminently likely to (i) endanger life, property, or public health; or (ii) adversely affect or impair the reliability of the New York State Transmission System, the Municipal System, Generators, or the electrical or transmission systems of others to which National Grid's electrical systems are directly or indirectly connected.

“**Emergency State**” shall mean the condition or state that the New York State Power System is in when an abnormal condition occurs that requires automatic or immediate manual action to prevent or limit loss of the New York State Transmission System or Generators that could adversely affect the reliability of the New York State Power System.

“ESB 752” shall have the same meaning as **“Bulletin No. 752.”**

“**Federal Power Act**” shall mean the Federal Power Act, as amended, 16 U.S.C. §§ 791a et seq. (“FPA”).

“**FERC**” shall mean the United States of America's Federal Energy Regulatory Commission or any successor organization.

“**Force Majeure**” shall have the meaning set forth in Article XIII.

“**Generator**” shall mean a device for the production of electricity interconnected within the Municipal exporting energy to the municipal electric system. The device shall be capable of supplying Energy, Capacity, and/or Ancillary Services (each as defined by the NYISO) that is accessible to the New York Control Area (NYCA).

“**Good Utility Practice**” means any of the practices, methods and acts engaged in or approved by a significant portion of the electric utility industry during the relevant time period, or any of the practices, methods and acts which, in the exercise of reasonable judgment in light of the facts known at the time the decision was made, could have been expected to accomplish the desired result at a reasonable cost consistent with good business practices, reliability, safety and expedition. Good Utility Practice is not intended to be limited to the optimum practice, method, or act, to the exclusion of all others, but rather to be acceptable practices, methods, or acts generally accepted in the region in which Municipal is located. Good Utility Practice shall include, but not be limited to, NERC (defined below) criteria, rules, guidelines and standards, NPCC (defined below) criteria, rules, guidelines and standards, New York State Reliability Council (defined below) criteria, rules, guidelines and standards, and NYISO (defined

below) criteria, rules, guidelines and standards, where applicable, as they may be amended from time to time including the rules, guidelines and criteria of any successor organization to the foregoing entities. When applied to Municipal, the term Good Utility Practice shall also include standards applicable to municipalities connecting to the distribution or transmission facilities or system of another utility.

“Governmental Authority” shall mean any federal, state, local or other governmental regulatory or administrative agency, court, commission, department, board, or other governmental subdivision, legislature, rulemaking board, tribunal, or other governmental authority having jurisdiction over any of the Parties, their respective facilities, or the respective services they provide, and exercising or entitled to exercise any administrative, executive, police, or taxing authority or power; provided, however, that for purposes of this Agreement, such term does not include Municipal, National Grid, NYISO, or any Affiliate thereof.

“Hazardous Substance(s)” shall mean those substances, materials, products or wastes which are classified as hazardous or toxic, or as petroleum, under any applicable federal, state or local law, including but not limited to the Comprehensive Environmental Response, Compensation and Liability Act (“CERCLA”), 42 U.S.C. section 9601, et seq., the Resource Conservation and Recovery Act (“RCRA”), section 6901, et seq., the Environmental Conservation Law, Article 27-1301, et seq., and the Navigation Law, Article 12 or any regulations promulgated thereunder, effective as of the date of execution of this Agreement, and the presence of which requires investigation, remediation, removal and/or cleanup under this Agreement.

“Interconnection Facilities” shall include all those National Grid and Municipal facilities and National Grid Properties or Municipal properties necessary to effect the transfer of Electricity from the National Grid Transmission System to Municipal, as such facilities are identified in more particularity in Exhibit A to this Agreement, and shall include any Modifications, replacements, retirements or upgrades made to the Interconnection Facilities.

“Interconnection Points” shall mean the points at which the Interconnection Facilities are connected to the National Grid Transmission System as indicated on Exhibit A.

“Interconnection Study” shall mean the necessary studies performed by National Grid for interconnection or Modification of an interconnection of the Municipal to the National Grid Transmission System. National Grid shall perform those studies that, in the judgment of National Grid, are necessary to determine (a) an appropriate Interconnection Point and delivery point, (b) conceptual equipment and the facilities necessary and desirable for the construction and operation of new or additional or modified facilities, (c) the interconnection voltage and operational constraints, (d) the estimated costs of facilities and/or the costs for National Grid's design, review, assistance and inspection of facilities to be designed and constructed by Municipal, (e) the estimated costs of any new reinforcements to or additions of new facilities to the National Grid Transmission System or the National Grid Interconnection Facilities required or recommended to be made in order for National Grid to interconnect with Municipal in accordance with NYISO Tariff rules and regulations and as such Interconnection Study is attached hereto as Exhibit B. Interconnection Study shall include the Interconnection Feasibility Study and the Interconnection System Reliability

Impact Study.

“Load Serving Entity (LSE)” shall mean an entity, including a municipal electric system and an electric cooperative, authorized or required by law, regulatory authorization, agreement, or contractual obligation to supply Energy, Capacity, and/or Ancillary Services to retail customers located within the NYCA, including an entity that takes service directly from the NYISO to supply its own load in the NYCA

“Loss” shall mean any and all losses relating to injury to or death of any person or damage to property, demand, suits, recoveries, costs and expenses, court costs, attorney fees, and all other obligations by or to third parties, arising out of or resulting from the Indemnified Party's performance or non-performance of its obligations under this Agreement on behalf of the indemnifying Party, except in cases of gross negligence or intentional wrongdoing by the Indemnified Party.

“Metering Authority” shall mean an entity designated by the NYISO that is responsible for a NYISO electric revenue metering system for its calibration, maintenance, operation, and reporting of metered data.

“Metering Equipment” shall mean all metering equipment installed or to be installed at the Interconnection Facilities by National Grid or other Metering Authority pursuant to this Agreement at the metering points, including but not limited to instrument transformers, MWh-meters, data acquisition equipment, transducers, remote terminal unit, communications equipment, phone lines, and fiber optics.

“**Modification**” means any new construction, new facilities, additions, reinforcements, alterations, improvements, appurtenances, replacements, retirements or upgrades made to the Interconnection Facilities, National Grid Transmission System, Municipal System, or Municipal Interconnection Facilities after the Effective Date of this Agreement.

"Modification" as it applies to the Interconnection Facilities or National Grid Transmission System shall also include Modifications which are required to support the operations of Municipal, including those required by: (i) changes in the operations of Municipal after the Effective Date as hereinafter defined, or (ii) changes in the technology employed at Municipal's Interconnection Facilities after the Effective Date.

“**Municipal**” shall mean the Village of Ilion, a municipal corporation duly organized and validly existing under the laws of the State of New York.

“**Municipal Interconnection Facilities**” shall mean facilities between the Municipal System and the National Grid Interconnection Facilities, owned by the Municipal that are necessary to effect the transfer of Electricity from the National Grid Transmission System to Municipal, as such facilities are identified in more particularity in Exhibit A to this Agreement.

“**Municipal System**” shall mean the electric transmission and distribution facilities that are owned, controlled and maintained by the Municipal.

“**National Grid**” shall mean Niagara Mohawk Power Corporation d/b/a National Grid and its successors and permitted assigns.

“**National Grid Interconnection Facilities**” shall mean facilities between the Municipal Interconnection Facilities and the Transmission System owned by National Grid that are necessary to effect the transfer of Electricity from the National Grid Transmission System to Municipal, as such facilities are identified in more particularity in Exhibit A to this Agreement.”

“**National Grid Properties**” shall mean those parcels of and/or interest in real property that National Grid uses for its Transmission System.

“**National Grid Transmission System**” means the properties, structures, facilities, equipment, devices, and apparatus wholly or partly owned or leased by, or under contract to, or under the control of National Grid or its Affiliates, necessary for the provision of services under the NYISO OATT and/or National Grid’s Retail Tariff .

“**NERC**” shall mean the North American Electric Reliability Corporation or any successor organization.

“**New York Control Area (NYCA)**” shall have the same meaning as in the Independent System Operator Agreement establishing the New York ISO (as defined below).

“**New York State Transmission System**” shall mean the entire New York State electric transmission system, which includes (i) the Transmission Facilities under ISO Operational Control; (ii) the Transmission Facilities Requiring ISO Notification; and (iii) all remaining transmission facilities within the New York Control Area.

“**NPCC**” shall mean the Northeast Power Coordinating Council or any successor organization.

“**NYISO**” shall mean the New York Independent System Operator, Inc.

“**NYISO OATT**” shall mean the FERC-approved Open Access Transmission Tariff for the NYISO, as it may be amended from time to time.

“**NYISO Services Tariff**” shall mean the NYISO Market Administration and Control Area Tariff, as filed with the Commission, and as amended or supplemented from time to time, or any successor tariff thereto.

“**NYISO Tariffs**” shall mean the NYISO OATT and the NYISO Services Tariff and any successors thereto.

“**NYPA**” shall mean the New York Power Authority or any successor thereto.

“**NYPSC**” means the New York Public Service Commission or any successor thereto.

“**NYSRC**” shall mean the New York State Reliability Council or any successor organization.

“**Reasonable Efforts**” shall mean, with respect to an action required to be attempted or taken by a Party under this Agreement, efforts that are timely and consistent with Good Utility Practice and are otherwise substantially equivalent to those a Party would use to protect its own interests.

“**Retail Tariff**” means Niagara Mohawk's Retail Tariff, New York Public Service

Commission ("NYPSC") No. 220 — Electricity as approved by the NYPSC and all subsequent revisions, as it may be amended from time to time.

“Transmission System” shall mean an interconnected group of electric delivery lines and associated equipment for moving or transferring electric energy in bulk between points of supply and points at which it is transformed for delivery over the distribution system lines to consumers, or is delivered to other electric systems.

“Upgrades” shall mean the upgrades and additions to National Grid's Transmission System identified in the Interconnection Study.

**ARTICLE II
AGREEMENT TO INTERCONNECT
DESCRIPTION OF INTERCONNECTION FACILITIES**

- 2.1 This agreement governs the terms and conditions under which the Municipal System is interconnected with, and operates in parallel with, the National Grid Transmission System. National Grid will own and operate the National Grid Interconnection Facilities. The Municipal shall own and operate the Municipal Interconnection Facilities. This Agreement does not address rights or obligations of the Municipal when providing Transmission Service or Generation Interconnecting Service under the NYISO OATT.
- 2.2 National Grid and Municipal are interconnected by means of existing Interconnection Facilities as identified on Exhibit A to this Agreement. Municipal and National Grid agree that the installation of the electrical equipment and the operation of the

Interconnection Facilities must meet or exceed the standards of Good Utility Practice, all requirements of Bulletin No. 752, any applicable Interconnection Study and the NYISO;

provided, however, that in the event of a conflict between the requirements, rules and regulations of the NYISO and the requirements of Bulletin No. 752, the requirements, rules and regulations of the NYISO shall govern.

- 2.3 Municipal shall use Good Utility Practice to own, operate and maintain, and make available to the extent consistent with Applicable Laws and Regulations the Municipal Interconnection Facilities and Municipal System. National Grid shall use Good Utility Practice to own, operate and maintain, and make available to the extent consistent with Applicable Laws and Regulations the National Grid Interconnection Facilities and National Grid Transmission System. National Grid does not, however, guarantee or warrant uninterrupted availability of the National Grid Interconnection Facilities and National Grid Transmission System. Any curtailment of deliveries over the National Grid Interconnection Facilities and National Grid Transmission System shall be governed by Good Utility Practice, the terms and conditions of the NYISO Tariffs, ESB 752, National Grid's standard practices and procedures.
- 2.4 National Grid reserves the right to operate disconnect switch(s) at the Interconnection Facilities with twenty four (24) hour notice to Municipal for National Grid requested maintenance or in an Emergency Condition after giving Municipal reasonable notice under the circumstances. National Grid shall exercise such right of disconnect (a) in accordance with Bulletin No. 752, (b) in a non-discriminatory manner, (c) in accordance with Good Utility Practice, and (d) in recognition of Section 7.4 of this Agreement.
- 2.5 The Municipal and National Grid shall each be responsible for protection of its respective

facilities consistent with Good Utility Practice and Applicable Reliability Standards.

In compliance with NPCC requirements and Good Utility Practice, Municipal shall provide, install, own, and maintain relays, circuit breakers and all other devices necessary to remove any fault contribution of the Municipal System or generators directly connected to the Municipal System to any short circuit occurring on the New York State Transmission System not otherwise isolated by National Grid's equipment, such that the removal of the fault contribution shall be coordinated with the protective requirements of the New York State Transmission System. Such protective equipment shall include, without limitation, a disconnecting device or switch with load-interrupting capability located between the Municipal System and the New York State Transmission System at a site selected upon mutual agreement (not to be unreasonably withheld, conditioned or delayed) of the Municipal and National Grid. Municipal shall be responsible for protection of the Municipal System and Municipal's other equipment from such conditions as negative sequence currents, over- or under-frequency, sudden load rejection, over- or under-voltage, and generator loss-of-field. Municipal shall be solely responsible to disconnect the Municipal system and Municipal's other equipment if conditions on the New York State Transmission System could adversely affect the Municipal System.

2.6 This Agreement does not waive, alter or impair the rights or obligations of any party under any other agreement.

2.7 No Transmission Delivery Service. The execution of this Agreement does not constitute a

request for, nor agreement to provide, any Transmission Service under the NYISO Tariffs, and does not convey any right to deliver electricity to any specific customer or Point of Delivery. If Municipal wishes to obtain Transmission Service on the New York State

Transmission System, then Municipal must request such Transmission Service in accordance with the provisions of the NYISO Tariffs.

- 2.8 The execution of this Agreement does not constitute a request for, nor agreement to provide Energy, any Ancillary Services or Installed Capacity under the NYISO Tariffs. If Municipal wishes to supply Energy, Installed Capacity or Ancillary Services, then Municipal will make application to do so in accordance with the NYISO Tariffs.
- 2.9 Both Parties agree that the Interconnection Facilities of either Party shall be used only for wholesale service to Municipal except as otherwise agreed to by the Parties or as required by Applicable Laws and Regulations.

ARTICLE III REPRESENTATIONS AND WARRANTIES OF PARTIES

- 3.1 Municipal is a municipal corporation duly organized and validly existing under the laws of the State of New York. Municipal is qualified to do business under the laws of the State of New York, is in good standing under the laws of the State of New York, has the power and authority to own its properties, to carry on its business as now being conducted, and to enter into this Agreement and the transactions contemplated herein and perform and carry out all covenants and obligations on its part to be performed under and pursuant to this Agreement, and is duly authorized to execute and deliver this Agreement and consummate the transactions contemplated herein.
- 3.2 National Grid is a corporation duly organized, validly existing and qualified to do

business under the laws of the State of New York, is in good standing under its certificate of incorporation and the laws of the State of New York, has the corporate authority to

own its properties, to carry on its business as now being conducted, and to enter into this Agreement and the transactions contemplated herein and perform and carry out all covenants and obligations on its part to be performed under and pursuant to this Agreement, and is duly authorized to execute and deliver this Agreement and consummate the transactions contemplated herein.

3.3 Municipal and National Grid each represents that: (a) it is not prohibited from entering into this Agreement and discharging and performing all covenants and obligations on its part to be performed under and pursuant to this Agreement; (b) upon the acceptance of the terms of this Agreement by FERC, the execution and delivery of this Agreement, the consummation of the transactions contemplated herein including the fulfillment of and compliance with the provisions of this Agreement will not conflict with or constitute a breach of or a default under any of the terms, conditions or provisions of any law, rule or regulation, any order, judgment, writ, injunction, decree, determination, award or other instrument or legal requirement of any court or other agency of government, or any contractual limitation, corporate restriction or outstanding trust indenture, deed of trust, mortgage, loan agreement, lease, other evidence of indebtedness or any other agreement or instrument to which it is a party or by which it or any of its property is bound and will not result in a breach of or a default under any of the foregoing; and (c) unless this Agreement is materially modified by any court or appropriate regulatory authority having jurisdiction and subsequently terminated, this Agreement shall be a legal, valid and binding obligation enforceable in accordance with its terms, except as limited by any subsequent

order of any court or appropriate regulatory authority having jurisdiction, or by any applicable reorganization, insolvency, liquidation, readjustment of debt, moratorium, or

other similar laws affecting the enforcement of rights of creditors generally as such laws may be applied in the event of a reorganization, insolvency, liquidation, readjustment of debt or other similar proceeding of or moratorium applicable to the Party and by general principles of equity (regardless of whether such enforceability is considered in a proceeding in equity or at law.)

ARTICLE IV INTERCONNECTION FACILITIES

4.1 Interconnection Facilities.

4.1.1 Exhibit A to this Agreement shall separately identify the Interconnection Facilities associated with the existing delivery point and the Interconnection Facilities associated with any new, modified, or upgraded delivery point. The Interconnection Facilities and the Upgrades associated with a new, modified, or upgraded delivery point shall be constructed and operated in accordance with the Interconnection Study performed by National Grid pursuant to this Agreement and in accordance with Good Utility Practice. The provisions of this Agreement addressing the design, engineering, procurement, and construction of Interconnection Facilities and Upgrades shall apply to the Interconnection Facilities and the Upgrades associated with any new, modified, or upgraded delivery point.

4.2 Obtaining Real Property Interests, and Necessary Licenses, Permits, and Approvals.

4.2.1 Municipal will acquire all interests in real property that are necessary for

National Grid to construct, operate and maintain the National Grid Interconnection Facilities or Modification in accordance with the terms and provisions of this Agreement.

4.2.2 National Grid, at Municipal's sole cost and expense, shall be responsible for preparing and maintaining in full force and effect all permits, authorizations, licenses, certificates and approvals necessary to design, construct, operate and maintain the National Grid Interconnection Facilities and/or Modifications. Municipal shall be responsible, at its own cost, for preparing and maintaining in full force and effect all permits, authorizations, licenses, certificates, and approvals necessary to design, construct, operate and maintain the Municipal Interconnection Facilities and effectuate its obligations under the Agreement with respect to the National Grid Interconnection Facilities. National Grid, at Municipal's sole cost and expense, shall fully cooperate with Municipal in order to prepare and maintain all permits, authorizations, licenses, certificates and approvals required by this Section. Municipal and National Grid agree to comply in all material respects with all federal, state and local environmental and other laws, ordinances, rules, regulations, permits, licenses, approvals, certificates and requirements thereunder in connection with the activities each performs pursuant to this Agreement.

4.2.3 Municipal agrees that, upon National Grid's reasonable request, prior to the transfer of any real property interest to National Grid under the terms of this Agreement, Municipal shall conduct, or cause to be conducted, at Municipal's sole cost and expense, sampling, soil testing, and any other methods of investigation

which would disclose the presence of any Hazardous Substance which has been released on the property or which is present upon the property by migration from an external source on the property and shall notify National Grid in writing as soon as reasonably practicable after learning of the presence of Hazardous Substance upon said property interest. Municipal shall provide National Grid with a copy of any report or data generated as a result of such sampling or soil testing activities. Municipal agrees to indemnify, defend, and save National Grid, its agents and employees, harmless from and against any loss, damage, liability (civil or criminal), cost, suit, charge (including reasonable attorneys' fees), expense, or cause of action, for the investigation, remediation, removal, clean-up, and/or management of any Hazardous Substance relating to any damages to any person or property resulting from the presence of such Hazardous Substance.

4.2.4 National Grid, at Municipal's sole cost and expense, shall be given the opportunity to inspect, be present for final testing and approve new or modified Municipal Interconnection Facilities and review all appropriate approvals, certificates, permits, and authorizations. Municipal shall be responsible for correcting any situations contrary to Good Utility Practice, Bulletin No. 752, any other applicable standards including applicable NERC and NPCC standards or any applicable NYISO requirements, which such requirements shall govern in the event of a conflict between NYISO and the requirements of Bulletin No. 752, which materially and adversely affect the operability of the National Grid Interconnection Facilities or are

contrary to applicable laws or permits, and for correcting any material deficiencies
which could impede the National Grid Interconnection Facilities pursuant to

this Agreement. Municipal shall be responsible for the costs associated with making such corrections. Prior to placing new or modified Municipal Interconnection Facilities in service, National Grid shall provide Municipal with documentation concerning the results of any National Grid review of any new or modified Municipal Interconnection Facilities.

- 4.2.5 Municipal shall be given the opportunity to inspect, be present for final testing and approve new or modified National Grid Interconnection Facilities and review all appropriate approvals, certificates, permits, and authorizations. National Grid shall correct any situations contrary to Good Utility Practice, Bulletin No. 752, National Grid's standards, procedures, practices and functional specification requirements, standard National Grid environmental, construction, forestry, and right-of-way management practices and procedures, National Grid's ROW Access, Maintenance and Construction Best Management Practices and National Grid's Transmission Right-of-Way Management Plans or any applicable NYISO requirements, which such requirements shall govern in the event of a conflict between NYISO and the requirements of Bulletin No. 752, which materially and adversely affect the operability of the Interconnection Facilities or are contrary to applicable laws or permits, and for correcting any material deficiencies which could impede the Interconnection Facilities pursuant to this Agreement. Prior to placing new or modified National Grid Interconnection Facilities in service, Municipal shall

provide National Grid with documentation concerning the results of any Municipal review of any new or modified National Grid Interconnection Facilities.

4.3 National Grid Design, Engineering and Construction Activities.

4.3.1 At Municipal's expense, National Grid agrees to design, engineer, and construct the National Grid Interconnection Facilities and/or Modifications and Upgrades in accordance with (a) the Interconnection Study, (b) Good Utility Practice and (c) National Grid and NYISO standards. Any disputes concerning the foregoing shall be resolved in accordance with Article XXI of this Agreement.

4.3.2 At Municipal's expense, National Grid agrees to procure any and all equipment and materials to be incorporated into the construction or modification of the National Grid Interconnection Facility and Upgrades.

4.3.3 All design, engineering, procurement, and construction activities performed by National Grid or a third party selected by National Grid shall be performed in accordance with a schedule and an estimated budget mutually agreed to by the Parties in advance of the commencement of such activities. National Grid, at Municipal's expense, agrees to inform Municipal on the first business day of each month and at such other times as Municipal reasonably requests of the status of all design, engineering, procurement, and construction activities performed by National Grid or a third party selected by National Grid, including, but not limited to, the following information: progress to date; a description of upcoming scheduled activities and events; the delivery status of all ordered equipment; a revised budget and cost report; and the identification of any event which National

Grid reasonably expects may delay construction of the Upgrades or the National
Grid Interconnection Facilities.

4.3.4 No design, engineering, procurement, or construction activities shall be undertaken by National Grid prior to Municipal's receipt of the Interconnection Study and until such time as Municipal issues a written notice to proceed with such activities and a money deposit received by National Grid for services to be rendered.

4.3.5 Municipal reserves the right, upon thirty (30) Calendar Days prior written notice to National Grid, to suspend at any time all work by National Grid associated with the design, engineering, procurement, construction of the Upgrades or with any design, engineering, and construction activities relating to the National Grid Interconnection Facilities and/or Modifications. Municipal acknowledges and agrees to reimburse National Grid for all costs incurred by National Grid that cannot be avoided, due to Municipal's suspending said work, in accordance with Article X of this Agreement. National Grid shall, if requested by Municipal, use Reasonable Efforts to suspend work by National Grid less than thirty (30) Calendar Days after National Grid receives notice from Municipal.

4.3.6 National Grid shall, at Municipal's expense, test the Interconnection Facilities, Modifications and Upgrades to ensure their safe and reliable operation in accordance with Good Utility Practice.

4.4 **Access Rights**

4.4.1 National Grid hereby grants to Municipal access, and licenses, as Municipal may require in connection with the construction and permitting of the Interconnection

Facilities and/or Modifications.

- 4.4.2 Municipal hereby grants to National Grid all necessary access, and licenses, including adequate and continuing rights of access to Municipal's property, as is necessary for National Grid to construct, operate, maintain, replace, remove the National Grid Interconnection Facilities and or Modifications in accordance with the terms of this Agreement and to exercise any other of its obligations under this Agreement. Municipal hereby agrees to execute such grants, deeds, licenses, instruments or other documents as National Grid may require to enable it to record such rights of way, easements, and licenses. Municipal also grants to National Grid rights of access to Municipal's property as necessary for any purpose reasonably related to this Agreement.
- 4.5 All expenditures incurred in acquiring franchises, necessary rights-of-way and associated permits and authorizations shall be the sole responsibility of Municipal. All costs associated with the transfer of real property rights to National Grid shall also be the responsibility of Municipal, including, but not limited to, closing costs, subdivision costs, transfer taxes and recording fees. National Grid shall be reimbursed for all costs it incurs in connection thereto and in carrying out the responsibilities hereunder as provided in Article X of this Agreement.
- 4.6 The rights-of-way for the Interconnection Facilities' newly constructed or modified by

Municipal pursuant to this Agreement shall be conveyed to National Grid in fee simple or by an easement approved by National Grid, with good and marketable title free and clear of all liens and encumbrances for a sum of \$1.00. With respect to any approved

conveyance of easements, Municipal shall subordinate pertinent mortgages to easement rights. Municipal shall indemnify, defend, and hold harmless National Grid, its agents and employees, from all liens and encumbrances against the property conveyed. Municipal further agrees to provide a complete field survey with iron pin markers showing the centerline of the entire right-of-way, a 40-year abstract of title, and a 10-year tax search. Municipal shall be required to provide National Grid, as a condition of and pursuant to conveyance to National Grid of any and all interests in real property acquired by Municipal on behalf of National Grid for the new or modified Interconnection Facilities, title insurance with a complete title report issued by a reputable title insurance company. In the event Municipal is unable to convey to National Grid good and marketable title to any parcel of land acquired pursuant to this Agreement, whether said defect in title is discovered prior to or after conveyance of said parcel of land, or in the event of a failure by Municipal to comply with National Grid's engineering standards or any applicable law, code, rule or regulation, then Municipal shall cure such defect or failure to comply, to the reasonable satisfaction of National Grid within six (6) months after receipt of written notice from National Grid to Municipal specifying the defect or failure to comply or within such other time as the parties may agree. All expenses and costs associated with curing said defects or failure to comply shall be Municipal's sole responsibility.

4.7 Each Party shall provide to the other Party copies of all necessary environmental, right-of-way, engineering, and other licenses, certificates, permits, approvals and as-built drawings.

4.8 Each Party shall also provide to the other, upon request and at the costs of the requesting

Party, reasonable documentation necessary to verify costs relating to the new Interconnection Facilities and/or Modifications, including, but not limited to, any costs relating to the design, engineering, construction, operation or maintenance of the Interconnection Facilities. Each Party shall have the right to request reasonable supporting documents which is necessary to substantiate its costs.

**ARTICLE V
OPERATION, MAINTENANCE, AND MODIFICATION OF FACILITIES**

5.1 Operation and Maintenance of Interconnection Facilities.

5.1.1 National Grid will own, operate, maintain and repair (repair includes, but is not limited to, replacement of existing equipment when required due to failure) the National Grid Interconnection Facilities in accordance with Good Utility Practice.

5.1.2 Municipal, at its own expense, will own, operate, maintain and repair (repair includes, but is not limited to, replacement of existing equipment when required due to failure) Municipal Interconnection Facilities in accordance with Good Utility Practice.

5.1.3 National Grid and Municipal shall confer regularly to coordinate the planning, scheduling and performance of preventive and corrective maintenance on the Interconnection Facilities. Absent an Emergency Condition, Municipal will use Reasonable Efforts to schedule outages on a date and time mutually acceptable to

both National Grid and the Municipal. Municipal will notify and coordinate with National Grid the schedule for scheduled outages for the upcoming year in

accordance with Bulletin No. 752, Good Utility Practice, NYISO practices and National Grid standard practices and, upon making any changes to such schedules thereafter, shall promptly notify and coordinate with National Grid regarding any such changes.

5.1.4 In furtherance of the Parties' mutual objective to preserve and maintain the reliability of the National Grid Transmission System and the Municipal System, the Parties agree to coordinate the planning and scheduling of any outages and any changes thereto in a manner that will preserve and maintain the reliability of, and minimize the effect on, the National Grid Transmission System and the Municipal System consistent with Good Utility Practice, Bulletin No. 752, NYISO practices and National Grid standard practices.

5.1.5 In furtherance of the Parties' mutual objective to preserve and maintain the reliability of the National Grid Transmission System and the Municipal System, the Parties agree, to coordinate the planning and scheduling of preventive and corrective maintenance in a manner that will preserve and maintain the reliability of the National Grid Transmission System and the Municipal System. The Parties shall conduct preventive maintenance and corrective maintenance activities as scheduled and planned, or as they become necessary, consistent with Good Utility Practice.

5.1.6 Municipal shall maintain its Municipal Interconnection Facilities in a safe and reliable manner in accordance with this Agreement.

5.1.7 National Grid will maintain its National Grid Interconnection Facilities in a safe

and reliable manner in accordance with this Agreement.

5.1.8 Municipal and National Grid acknowledge that the purpose of the interconnection referred to herein is to allow Municipal to obtain transmission service on a non-discriminatory basis. Any actions taken by National Grid with respect to Municipal or the Municipal System shall not be unduly discriminatory or preferential.

5.2 **Modification of the Interconnection Facilities.**

5.2.1 National Grid shall retain the discretion to determine whether, when, and in what manner Modifications to the National Grid Interconnection Facilities are required by Good Utility Practice and, as soon as reasonably practicable, but no later than three months advance written notice including an estimate of the cost of the Modification, shall advise Municipal when it makes such a determination and whether performing the Modification, or the Modification itself, is expected to interrupt the flow of power over the Interconnection Facility. National Grid shall use Reasonable Efforts to minimize any interruption of power flow over or to the Interconnection Facilities. National Grid shall construct, operate, maintain and repair any such Modification, and Municipal shall reimburse National Grid for all actual costs and expenses of constructing, operating and maintaining the Modification.

5.2.2 If a Modification to the National Grid Interconnection Facilities is required to support the operations of Municipal, National Grid shall construct, operate,

maintain and repair, at Municipal's expense, any such Modification, and
Municipal shall reimburse National Grid for all actual costs and expenses of

constructing the Modification. National Grid shall provide three months advance written notice including an estimate of the cost of the Modification to Municipal to the extent reasonably practicable.

5.2.3 Municipal shall give National Grid three months advance written notice of any planned Modifications to the Municipal Interconnection Facilities.

5.2.3.1 Such notice shall include plans, specifications, information and operating instructions relating to the impact of planned Modifications on the National Grid Transmission System or the National Grid Interconnection Facilities, National Grid's electric operations and the Municipal System.

5.2.3.2 If National Grid determines that such Modification would have a material adverse effect upon National Grid's operations or the operations of National Grid's customers, then National Grid shall so notify Municipal. In the event that Municipal elects to continue with such Modification, National Grid shall be entitled to designate the earliest date upon which Municipal may begin the Modification, provided, however, that National Grid shall not designate a beginning date that is later than eighteen (18) months after receipt of the notice mandated by Section 5.2.3. Municipal shall be responsible for all costs associated with such

Modification, including any costs incurred by National Grid
associated with ensuring that the National Grid Interconnection

Facilities would be compatible with such Modification.

5.2.3.3 Notwithstanding the foregoing, should Municipal propose a schedule for performing a Modification that National Grid in good faith determines may adversely affect National Grid's operations or the operations of National Grid's customers, National Grid may reject such schedule, but only to the extent such schedule is not in accordance with Good Utility Practice.

5.2.3.4 All Modifications to the National Grid Transmission System or the National Grid Interconnection Facilities, and any resulting effects on the National Grid Transmission System shall meet the rules and requirements of NERC, NPCC, NYSRC, the NRC, and the NYISO or their respective successors, the standards of Good Utility Practice, and the requirements of Bulletin No. 752; provided, however, that in the event of a conflict between the rules and requirements of the NYISO and the requirements of Bulletin No. 752, the rules and requirements of the NYISO shall govern.

5.2.4 If Municipal is permitted by National Grid to construct, at its own expense, a Modification to the National Grid Interconnection Facilities subject to the terms of this Agreement, then Municipal shall transfer all rights, title and interest in such Modification to National Grid upon completion of construction and shall execute all

necessary documents to effectuate transfer of ownership thereof to National Grid,
provided however, that design, engineering, and construction activities on to the

existing National Grid Interconnection Facilities shall be performed by National Grid, or by a third party selected by National Grid in accordance with Good Utility Practice and at Municipal's expense. Municipal shall obtain any necessary permits, authorizations and rights-of-way for the Modification, in accordance with this Agreement, the costs thereof to be paid by Municipal. Municipal shall transfer any such rights-of-way to National Grid. National Grid will accept transfer of ownership and energize the Modification, upon Municipal 's satisfaction, at Municipal 's expense, of the following: (a) the modification shall comply with National Grid's engineering standards and all applicable laws, codes, rules and regulations; (b) the transfer of all rights of way necessary for the Modification shall be made in fee simple (by warranty deed free and clear of all liens and encumbrances) for consideration in the amount of One Dollar and (c) a land survey and title insurance for the Modification shall be provided to National Grid by Municipal in a form and amount acceptable to National Grid. The Municipal shall be responsible for any and all taxes caused by the transfer of ownership.

5.3 **[Not used]**

5.4 **Interconnection of Third Party Facilities to Municipal System and Upgrades Related to Municipal Expansions.**

5.4.1 Municipal will provide advance written notice to National Grid prior to the proposed interconnection to the Municipal System of any: (1) new Generator; or (2) 10% increase or more in the capacity of an existing Generator connected to the

Municipal System. Such written notice shall be provided within 30 Calendar Days of Municipal receiving an interconnection or service request or notice of a proposed increase in Generator capacity.

5.4.2 National Grid or the NYISO, as applicable, will have the right to perform an Interconnection Study, if necessary and as appropriate, in order to determine the extent of the impact of the proposed interconnection of, or increase in, Generator capacity on the National Grid Transmission System or Interconnection Facilities. National Grid or the NYISO shall perform any such studies pursuant to any applicable NYISO requirements. If upgrades to the National Grid Transmission System or National Grid Interconnection Facility are required as a result of the proposed interconnection or increase in Generator capacity, such upgrades will be performed by National Grid or a third party designated by National Grid at the expense of either the Municipal to the extent consistent with FERC policy or the owner of the Generator, consistent with Attachment S to the NYISO OATT, Attachment X to the NYISO OATT, or Attachment Z to the NYISO OATT, as applicable.

5.4.2.1 Municipal, the owner of the Generator, or the owner of the load connecting to the Municipal System shall reimburse National Grid for all actual costs and expenses of studying, constructing, operating, and maintaining National Grid Interconnection Facility's upgrades.

5.4.2.2 If the Transmission System upgrades are the result of a Generator

interconnection, Municipal or the owner of the Generator connecting to the

Municipal System shall reimburse National Grid for all actual costs and expenses of studying and constructing the Transmission System upgrades to the extent consistent with Attachment S to the NYISO OATT.

5.4.2.3 Every year Municipal will provide National Grid with a ten year load forecast. Municipal will also provide advance written notice to National Grid prior to an otherwise unanticipated peak load increase of ten percent or greater over the peak load stated in Exhibit A. The parties will mutually agree as to the scope and methodology of any necessary impact study. If any required National Grid Interconnection Facility or Transmission System upgrades are the result of a load interconnection, Municipal, or the owner of the load connecting to the Municipal System shall reimburse National Grid for all actual costs and expenses of studying and constructing, operating, and maintaining the Transmission System upgrades to the extent consistent with FERC policy.

5.4.2.4 The construction of Transmission System upgrades by National Grid in accordance with this Section 5.4.2 shall be subject to National Grid's ongoing ability to recover the prudently incurred costs associated with such Transmission System upgrades through rates set forth in transmission and retail tariffs, provided that nothing in this Section 5.4.2.4 shall limit the obligation of National Grid to construct all Transmission System upgrades needed to comply with Applicable Laws and Regulations or Applicable Reliability Standards.

ARTICLE VI POWER DELIVERIES

6.1 **Metering.**

6.1.1 The parties understand that metering shall be performed by the NYPA in accordance with a separate agreement. Municipal shall comply with NYPA's Municipal System Interconnect Revenue Metering requirements. Municipal shall enter into arrangements for NYPA to provide and maintain compatible revenue quality metering equipment. Such metering equipment shall record the delivery of energy, including reactive power, in such a manner so as to measure on an hour-by-hour basis total power and energy delivered to Municipal. Such metering equipment shall be installed at a location mutually agreeable to Municipal, NYPA and National Grid. Such metering equipment may be owned and/or operated by a third party Metering Authority but must, at a minimum, satisfy NYISO and NYSDPS quality and technical requirements.

Additional metering requirements may apply to satisfy the needs of other suppliers of power to Municipal. The costs to implement and operate such other requirements shall not be at the expense of National Grid nor shall such requirements interfere with National Grid's requirements. Each Party agrees to use Reasonable Efforts to comply with such additional metering requirements as may be required from time to time.

6.1.2 In the case where generation exists within the Municipal System, depending on the generation size or its final market destination, additional metering equipment may be required to satisfy National Grid's, the NYISO's, the Municipal's or NYPA's needs.

Where generation exists within the Municipal System and is consumed by Municipal (i.e., is not sold to the NYISO or other markets) and is below a mutually agreed upon MW threshold, no additional metering will be required under this Agreement.

Where generation exists within the Municipal System and it is sold to the NYISO or other markets, or the generation is above a mutually agreed upon MW threshold, the Municipal, at its own expense, shall provide all necessary communication equipment and transmission mediums such as telephone lines and any necessary protection for such communication equipment and related equipment, and shall furthermore be responsible for all communication required by National Grid for observability of the generator production and generator station load, data, and transmission equipment status, and as also may be required by NYPA, the NYPSC or the NYISO. Except as otherwise agreed, Municipal shall be responsible for the purchase, ownership and maintenance of all telemetering equipment required at or connected to Municipal's facilities.

Municipal shall provide, install and own National Grid approved or specified test switches in the transducer circuits that have been also approved or specified by National Grid. Municipal shall be responsible for any and all costs involved in the relocation of communication circuits and transmission mediums that may be required by National Grid, NYPA, the NYPSC, or the NYISO from time to time. Nothing in this Agreement shall preclude Municipal from entering into

an agreement or other arrangement under which a Generator or Generators
assume responsibility for costs to be incurred by Municipal under this Article

VI. Any circumstance where National Grid is requested to provide data to the NYISO for a Generator or Generators within the Municipal System will be addressed in a separate agreement.

- 6.1.3 Electricity received at the delivery points by Municipal hereunder shall be measured by electric watt hour meters of a type approved by the NYPSC and NYPA. These metering facilities will be installed, owned, and maintained by NYPA and shall be sealed by NYPA, with the seal broken only upon occasions when the meters are to be inspected, tested or adjusted and representatives of both National Grid and Municipal are present. The metering and installation costs are to be borne by Municipal. The meters shall be maintained in accordance with the rules set forth in 16 NYCRR Part 92, as amended from time to time, and with Good Utility Practice.
- 6.1.4 National Grid, at its own expense, may elect to install its own meters in addition to Municipal or NYPA's meters. Such meters shall meet the requirements of 16 NYCRR Part 92, as may be amended from time to time.
- 6.1.5 In the event the Municipal desires access to meter information, Municipal, at its own expense, shall be responsible for purchasing and installing software, hardware and/or other technology that may be required to access such meter information. The software, hardware and/or other technology installed for this purpose shall be in compliance with any applicable NYPSC, NYPA and National Grid rules, requirements, or standards.
- 6.1.6 Municipal grants to the employees and agents of National Grid the right of

access to Municipal Interconnection Facilities at all reasonable times for such purposes of the reading of meters; inspection of meters, their wiring and related equipment; and installing, operating, maintaining, disconnecting and removing of any or all of the property belonging to National Grid. If Municipal refuses such access to the meters or other National Grid equipment, or if access is obstructed or hazardous, National Grid shall provide notice that Municipal shall have five (5) Calendar Days in which to permit access, or remove any obstruction or hazard. If, after five (5) Calendar Days from the receipt of the notice, Municipal does not permit access or remove any obstruction or hazard, it will constitute an event of breach, and National Grid may take any action in accordance with this Agreement, including disconnecting Municipal from the Transmission System in accordance with Good Utility Practice, after providing reasonable notice.

6.2 Losses.

If the metering equipment and the Interconnection Points are not at the same location, the metering equipment shall record delivery of Electricity in a manner that accounts for losses occurring between the metering points and the Interconnection Points. The metering point, the delivery points, associated equipment and distance between the metering point and the delivery points shall be as set forth in Exhibit A. If the metering points are changed to another location, losses in accordance with this Section will be recalculated.

ARTICLE VII

7.1 **Obligations.** Each Party shall comply with the Emergency State procedures of NYISO, the Applicable Reliability Councils, Applicable Laws and Regulations, and any emergency procedures agreed to by the NYISO Operating Committee.

7.2 **Notice.** National Grid shall notify Municipal promptly when it becomes aware of an Emergency State that affects the National Grid Interconnection Facilities or the National Grid Transmission System that may reasonably be expected to affect the Municipal System. Municipal shall notify NYISO and National Grid promptly when it becomes aware of an Emergency State that affects the Municipal System that may reasonably be expected to affect the National Grid Interconnection Facilities or the New York State Transmission System. To the extent information is known, the notification shall describe the Emergency State, the extent of the damage or deficiency, the expected effect on the operation of Municipal's or National Grid's facilities and operations, its anticipated duration and the corrective action taken and/or to be taken. The initial notice shall be followed as soon as practicable with written notice.

7.3 **Immediate Action.** Unless, in Municipal's reasonable judgment, immediate action is required, Municipal shall obtain the consent of National Grid, such consent to not be unreasonably withheld, prior to performing any manual switching operations at the Interconnection Facilities in response to an Emergency State either declared by NYISO, National Grid or otherwise regarding New York State Transmission System.

7.4 **NYISO and National Grid Authority.**

7.4.1 **General.** NYISO or National Grid may take whatever actions with regard to the New York State Transmission System (including the National Grid Transmission System) or the National Grid Interconnection Facilities it deems necessary during an Emergency State in order to (i) preserve public health and safety, (ii) preserve the reliability of the New York State Transmission System or the National Grid Interconnection Facilities, (iii) limit or prevent damage, and (iv) expedite restoration of service.

National Grid shall use Reasonable Efforts to minimize the effect of such actions or inactions on the Municipal System. The Parties understand that any actions the NYISO is authorized to take under this Section 7.4.1 are conditioned upon the NYISO's use of Reasonable Efforts to minimize the effect of such actions or inactions on the Municipal System. NYISO or National Grid may, on the basis of technical considerations, require the Municipal System to mitigate an Emergency State by taking actions necessary and limited in scope to remedy the Emergency State.

Any actions taken by National Grid with respect to Municipal or the Municipal System shall not be unduly discriminatory or preferential.

7.4.2 **Disconnection.** NYISO or National Grid may disconnect the Municipal System when disconnection is necessary under Good Utility Practice due to an Emergency

State. These rights are separate and distinct from any right of Curtailment of NYISO pursuant to the NYISO OATT. When National Grid can schedule

the disconnection in advance, National Grid shall notify Municipal of the reasons, timing and expected duration of the disconnection. National Grid shall coordinate with the Municipal using Good Utility Practice to schedule the disconnection during periods of least impact to the Municipal and the New York State Transmission System. The Parties understand that any disconnection the NYISO is authorized to make under this Section 7.4.2 are conditioned upon: (i) the NYISO's notification of the Municipal of the reasons, timing and expected duration of the disconnection; and (ii) the NYISO's coordination with the Municipal using Good Utility Practice to schedule the disconnection during periods of least impact to the Municipal and the New York State Transmission System. Any disconnection shall continue only for so long as reasonably necessary under Good Utility Practice. The Parties shall cooperate with each other to restore the Municipal System, and the New York State Transmission System to their normal operating state as soon as practicable consistent with Good Utility Practice.

7.5 Municipal Authority. Consistent with Good Utility Practice and this Agreement, the Municipal may take whatever actions or inactions with regard to the Municipal System or Municipal Interconnection Facilities during an Emergency State in order to (i) preserve public health and safety, (ii) preserve the reliability of the Municipal System or Municipal Interconnection Facilities, (iii) limit or prevent damage, and (iv) expedite restoration of service. Municipal shall use Reasonable Efforts to minimize the effect of such actions or

inactions on the New York State Transmission System and the National Grid

Interconnection Facilities. National Grid shall use Reasonable Efforts to assist

Municipal in such actions.

- 7.6 **Limited Liability.** Except as otherwise provided in the NYISO Tariffs, no Party shall be liable to another Party for any action it takes in responding to an Emergency State so long as such action is made in good faith and is consistent with Good Utility Practice and the NYISO Tariffs.

ARTICLE VIII INSURANCE PROVISIONS

- 8.1 The Parties agree to maintain at their own expense insurance policies issued by reputable insurance companies acceptable to the other Party or self-insure to the extent permitted by this Article VIII which provide insurance coverage which meets or exceeds the following requirements:

8.1.1 Workers Compensation and Employers Liability Insurance as required by the State of New York. If required, coverage shall include the U.S. Longshoremen's, and Harbor Workers Compensation Act & the Jones Act.

8.1.2 Commercial General Liability (Including Contractual Liability), covering all activities and operations to be performed by it under this Agreement, with the following minimum limits:

(A) Bodily Injury - \$1,000,000/\$1,000,000

Property Damage - \$1,000,000/\$1,000,000

OR

NYISO Agreements --> Service Agreements --> NMPC and Village of Ilion SA 2416

(B) Combined Single Limit - \$1,000,000 per occurrence

AND

(C) General Aggregate & Product Aggregate - \$2,000,000 each.

8.1.3 Automobile Liability, covering all owned, non-owned and hired vehicles used in connection with all operations, work or services to be performed by or on behalf of any contractor under or in connection with this Agreement with **minimum** limits of:

Bodily Injury - \$500,000 per occurrence; 1,000,000 aggregate

Property Damage - \$500,000 per occurrence

OR

Combined Single Limit - \$1,000,000 per occurrence

8.1.4 Umbrella or Excess Liability, coverage with a minimum limit of \$ 4,000,000.

8.2 Each Party shall include the other Party as an additional insured for all coverage's except Workers Compensation and Employers Liability Insurance. For National Grid, please use the following wording: National Grid USA, its direct and indirect parents, subsidiaries and affiliates.

8.3 In the event any Party uses subcontractors in connection with this Agreement, that Party shall require all subcontractors to provide the same insurance coverage's set forth in Section 8.1.

8.4 Upon request by any Party, the other Party shall promptly provide the requesting Party with either evidence of insurance or certificates of insurance evidencing the insurance coverage required under Sections 8.1 and 8.2. Municipal shall provide such certificates or evidence of insurance to National Grid at the following address:

**Transmission Commercial
40 Sylvan Rd
Waltham, MA. 02451**

National Grid shall provide such certificates or evidence of insurance to Municipal at the

following address:

Village of Ilion, NY

Attn. Mayor Terry Leonard

49 Morgan Street

Ilion, NY 13357

Fax: 315-894-6050

Should any of the above described policies be cancelled before the expiration date thereof, notice will be given in accordance with the policy provisions.

- 8.5 If any Party fails to secure or maintain any insurance coverage, or any insurance coverage is canceled before the completion of all services provided under this Agreement, and that Party fails immediately to procure such insurance as specified herein, then the other Party has the right to procure such insurance and, at its option, either bill the cost thereof to the failing Party or deduct the cost thereof from any sum due the failing Party under this Agreement.
- 8.6 To the extent requested, each Party shall furnish the other Party with copies of any accident report(s) sent to either Party's insurance carriers covering accidents or incidents occurring in connection with or as a result of the performance of the work under this Agreement.

- 8.7 Each Party shall comply with any governmental and/or site specific insurance requirements even if not stated herein.
- 8.8 Nothing contained in these insurance requirements is to be construed as (A) limiting the extent, if any, to which any Party is responsible for payment of damages, or (B) limiting, diminishing, or waiving the obligation of any Party to indemnify, defend and save harmless the other Party in accordance with this Agreement.
- 8.9 Notwithstanding the foregoing, Municipal and National Grid may each self-insure to meet the minimum insurance requirements of Article VIII to the extent each maintains a self-insurance program; provided that, such Party's senior debt is rated at investment grade, or better, by Standard & Poor's. For any period of time that a Party's senior debt is unrated by Standard & Poor's or is rated at less than investment grade by Standard & Poor's, such Party shall comply with the insurance requirements applicable to it under Article VIII. In the event that a Party is permitted to self-insure pursuant to this Article VIII, it shall notify the other Party that it meets the requirements to self-insure and that its self-insurance program meets the minimum insurance requirements in a manner consistent with that specified in Article VIII.
- 8.10 For purposes of complying with this Article VIII only, the term "Parties" shall mean Municipal and National Grid USA.

**ARTICLE IX
COMPLIANCE WITH LAWS**

- 9.1 National Grid and Municipal each agree to comply in all material respects with all

NYISO Agreements --> Service Agreements --> NMPC and Village of Ilion SA 2416

applicable federal, state and local laws, ordinances, rules, regulations, permits, licenses,

approvals, certificates, and requirements thereunder in connection with all its activities performed pursuant to this Agreement, including, but not limited to all design, environmental, regulatory, engineering, construction, and property acquisition activities.

9.2 If either Party observes that any requirement specified in this Agreement is at variance with any governing laws, ordinances, rules, regulations, permits, licenses, approvals, certificates and requirements thereunder, such Party shall promptly notify the other in writing before incurring any further liability, expense or obligation. National Grid and Municipal shall in good faith attempt to reform this Agreement to comply with the aforementioned laws, ordinances, rules, regulations, permits, approvals, or certificates. If National Grid and Municipal are unable to do so, either Party may terminate this Agreement.

9.3 **Environmental Releases by Municipal.** Municipal shall notify National Grid first verbally, and then in writing, of the Release of Hazardous Substances that may reasonably be expected to affect Grid property as soon as possible but not later than twenty-four (24) hours after the incident, and shall promptly furnish to National Grid copies of any reports filed with any governmental agencies addressing such events. If Hazardous Substances are released or reasonably believed to have been released onto National Grid's property, Municipal, at its own expense, shall conduct, or cause to be conducted, sampling, soil testing, and any other methods of investigation which would disclose the presence and extent of contamination by any Hazardous Substance which has been released onto National Grid's property and shall notify National Grid in writing as soon as reasonably practicable after

learning of the presence of any Hazardous Substance upon National Grid's property.

Municipal shall provide National Grid with a copy of any report or data generated as a result of

such sampling or soil testing activities. Municipal shall notify National Grid immediately of any type of remediation activities. Municipal shall provide National Grid thirty (30) Calendar Days written notice prior to conducting any asbestos or lead abatement activities, and shall promptly furnish to National Grid (i) copies of any reports filed with any governmental or regulatory agencies pertaining to such abatement activities, (ii) copies of applications for permits to conduct abatement activities, and (iii) copies of all permits authorizing abatement activities. Municipal agrees to indemnify, defend, and save harmless National Grid, its agents and employees, from and against any loss, damage, liability (civil or criminal), cost, suit, charge (including reasonable attorneys' fees), expense, or cause of action, for the removal or management of any Hazardous Substance and/or relating to any damages to any person or property resulting from presence of such Hazardous Substance.

- 9.4 **Environmental Releases by National Grid.** National Grid shall notify Municipal first verbally, and then in writing, of the Release of Hazardous Substances that may reasonably be expected to affect Municipal property as soon as possible but not later than twenty-four (24) hours after the incident, and shall promptly furnish to Municipal copies of any reports filed with any governmental agencies addressing such events. If Hazardous Substances are released or reasonably believed to have been released onto Municipal's property, National Grid, at its own expense, shall conduct, or cause to be conducted, sampling, soil testing, and any other methods of investigation which would disclose the presence and extent of contamination by any Hazardous Substance which has been released onto Municipal's property and shall notify Municipal in writing as soon as reasonably practicable after

learning of the presence of any Hazardous Substance upon Municipal's property. National
Grid shall notify Municipal immediately of any type of remediation activities. National

Grid shall provide Municipal thirty (30) Calendar Days written notice prior to conducting any asbestos or lead abatement activities, and shall promptly furnish to Municipal (i) copies of any reports filed with any governmental or regulatory agencies pertaining to such abatement activities, (ii) copies of applications for permits to conduct abatement activities, and (iii) copies of all permits authorizing abatement activities. National Grid agrees to indemnify, defend, and save harmless Municipal, its agents and employees, from and against any loss, damage, liability (civil or criminal), cost, suit, charge (including reasonable attorneys' fees), expense, or cause of action, for the removal or management of any Hazardous Substance and/or relating to any damages to any person or property resulting from presence of such Hazardous Substance.

9.5 Both Parties shall promptly provide to the other Party, all relevant information, documents, or data which may reasonably be expected to pertain to the safety, security or reliability of the immediate Transmission System that Municipal is connected to.

ARTICLE X COST PAYMENTS

10.1 National Grid shall invoice Municipal monthly in an amount equal to National Grid's actual costs and expenses for which National Grid is to be reimbursed under this Agreement. However, if and as requested by National Grid, Municipal shall reimburse National Grid for costs and expenses in advance of National Grid incurring the aforementioned costs or expenses. To the extent National Grid receives any costs and expenses from Municipal under this Agreement, National Grid shall make appropriate

credits in accordance with any applicable formula transmission rate to avoid duplicative charges.

10.2 Municipal shall pay National Grid within thirty (30) Calendar Days of invoicing for all costs incurred by National Grid under this Agreement, including, but not limited to, the cost of; constructing the Interconnection Facility, Upgrades and Modifications; relocations, rearrangements, abandonments or retirements; operation, maintenance, repair and spare parts; metering, telemetering and communication media; and miscellaneous studies, testing, documentation and items performed by National Grid at the request of Municipal.

10.2.1 Municipal shall be responsible for all actual costs of National Grid, including, but not limited to, capital costs, labor (direct and distributable); labor fringe benefits and payroll taxes; invoices for material, contractors, consultants, etc.; employee expenses; storeroom material and handling; any and all costs and expenses resulting from damage to National Grid property not otherwise covered by insurance including risk of loss of the Interconnection Facility during construction; sales and/or use taxes on invoices and material; transportation; allowance for funds used during construction (AFUDC); administrative and general expense (A&G) at the current rate applied to the total of all costs; and state, county, local sales and use taxes applied to the total of all costs and administrative and general and expenses associated with the acquisition, ownership, operation, repair, spare parts, A&G, inspection, design review, engineering, surveying, project management and coordination, testing of electrical equipment and installation of energy management system remote terminal units and revenue meters, construction, construction monitoring, financing, maintenance, environmental and regulatory permitting and licensing of, taxes and transfer of title of any new facilities and Modifications.

10.2.2 Municipal shall be responsible for any and all costs or expenses that are incurred by National Grid pursuant to this Agreement for the operation, maintenance and repair of the National Grid Interconnection Facilities including any Modifications transferred to National Grid.

10.2.2.1 Municipal shall reimburse National Grid on a monthly basis for operation, maintenance, and repair costs and expenses. However, if and as requested by National Grid, Municipal shall reimburse National Grid for operation, maintenance, and repair costs and expenses in advance of National Grid incurring the aforementioned costs or expenses.

10.2.2.2 Operation, maintenance and repair costs and expenses shall include all actual costs and expenses associated with operation, maintenance, repair, spare parts, inspection, engineering and legal services, contract administration, right-of-way acquisition, working capital (to the extent National Grid has not previously recovered such capital costs), and A&G (including material adders, overhead charges, and transportation charges).

10.2.3 **[Not used]**

10.2.4 Municipal shall be responsible for any and all federal, state, local, and foreign taxes levied or assessed upon National Grid for payments made to National Grid by Municipal for services provided under this Agreement including, but not limited to,

the following: transfer tax, property tax, federal income tax, and New York State taxes, including New York income or gross receipts, sales and use taxes; provided, however, that National Grid shall pay any applicable interest or penalty incurred as a result of National Grid's delay in paying such taxes or seeking reimbursement from Municipal. If any form of tax, other than income or excess profits tax, under any present or future federal, state or other law different from or in addition to the taxes for which participation in or payment by Municipal is provided herein or elsewhere in this Agreement, is required to be paid, levied or assessed against or incurred by National Grid with respect to any property, property right, commodity, or service involved in, resulting from or accruing from National Grid's performance under this Agreement, which such different or additional tax would not be required to be paid by National Grid in the absence of this Agreement and, with respect to such different or additional tax, no obligation of Municipal to participate or pay would have attached under the provisions of this Agreement elsewhere than in this Section, then in such event Municipal shall fully reimburse National Grid for the full amount of such different or additional tax paid by National Grid.

10.2.4.1 If National Grid receives a refund from the taxing authorities of any amounts paid by Municipal, National Grid shall refund to Municipal such amount refunded National Grid (net of expenses related to obtaining the refund) within thirty (30) Calendar Days of receiving such refund.

10.2.4.2 Notwithstanding the foregoing, Municipal, at its own expense, shall have the right to require National Grid to seek a Private Letter Ruling from the

Internal Revenue Service on whether any of the sums paid to National Grid by Municipal under the terms of this Agreement for the construction of the facilities contemplated herein are subject to U.S. federal taxation. To the extent that the Private Letter Ruling concludes that any such sums are taxable to National Grid., Municipal shall reimburse National Grid for all such taxes consequently imposed upon National Grid in accordance with the terms of this Agreement. Municipal shall reimburse National Grid for all costs, including but not limited to legal fees, associated with seeking the Private Letter Ruling.

10.2.5 Increased income tax to National Grid arising from Municipal's payment or reimbursement of tax under the preceding provisions will be addressed in the following manner. Any net actual U.S. federal income tax or New York State tax (collectively, for this Section 10.2.5 "Tax"), if any, arising out of any payment or reimbursement of any tax by Municipal under this Article shall be reimbursed to National Grid. The amount reimbursed to National Grid under this Section shall consist of (1) the Tax arising under this Section (the "First Amount"); plus (2) the net actual Tax imposed on the First Amount (the "Second Amount"); plus (3) the net actual Tax imposed on the Second Amount (the "Third Amount"); and plus (4) the net actual Tax imposed on the Third Amount and on each succeeding amount until the final amount is less than one dollar.

10.2.6 Municipal as a municipality is generally exempt from taxation and upon

execution of the Agreement, Municipal shall immediately provide to National Grid all documentation required by National Grid to verify Municipal's tax exemption status.

- 10.3 National Grid agrees to cooperate with the Municipal in attempting to minimize National Grid's and Municipal's costs under this Article, provided Municipal reimburses National Grid for all costs incurred by National Grid in connection with such cooperation, including reasonable attorneys' fees and expenses, and provided further that Municipal shall indemnify, defend, and save harmless National Grid, its agents and employees, against any and all penalties, judgments, fines (civil or criminal), or other costs that may be imposed by any Governmental Authority as a result hereof.
- 10.4 National Grid shall include with each invoice, documentation supporting the costs, expenses, and/or taxes incurred by National Grid in the previous quarter, or to be incurred in the next quarter, as provided for in Section 10.2.2.1. National Grid will provide such documentation from its standard accounting methods. Within thirty (30) Calendar Days from date of the invoice, Municipal shall pay the invoice and/or notify National Grid that Municipal disputes, in whole or in part, any of the costs, expenses, and/or taxes reflected in the invoice and shall specify with particularity the reasons for such dispute. If Municipal disputes any invoice or portion thereof, Municipal shall immediately place into an independent escrow account an amount equal to the portion of the invoice it disputes. Such amount shall remain in escrow until the dispute between the Parties is resolved in accordance with Article XXI of this Agreement. If any portion of any invoice Municipal has not disputed remains unpaid thirty (30) Calendar Days from the invoice

date, National Grid shall apply to the unpaid balance, and Municipal shall pay, a finance charge at the rate of one and one-half percent (1.5%) per month, but in no event more than the maximum allowed by law.

10.5 National Grid has undertaken to construct or modify the National Grid Interconnection Facility solely at the request of Municipal and in reliance on Municipal's commitment to pay all of the costs of constructing and maintaining the Interconnection Facility. The Interconnection Facility and all of its components shall at all times be classified as substation leads that may be directly charged to Municipal and not as improvements to National Grid's Transmission System, except to the extent that National Grid hereafter voluntarily elects to reclassify those facilities as improvements to its Transmission System. Nothing contained in this Section 10.5 shall be construed as limiting Municipal's rights under Section 206 of the FPA.

10.6 **Disputes.** In the event of a billing dispute between National Grid and Municipal, National Grid will continue to perform under this Agreement as long as Municipal: (i) continues to make all payments not in dispute; and (ii) pays to National Grid or into an independent escrow account the portion of the invoice in dispute, pending resolution of such dispute. If Municipal fails to meet these two requirements for continuation of service, then National Grid may provide notice to Municipal of a Default. Within thirty (30) Calendar Days after the resolution of the dispute, the Party that owes money to the other Party shall pay the amount due with interest calculated in accord with the methodology set forth in FERC's regulations at 18 C.F.R § 35.19a(a)(2)(iii).

ARTICLE XI

NOTICES

11.1 All notices required or permitted under this Agreement shall be in writing and shall be personally delivered or sent by certified or registered first class mail (return receipt requested, postage prepaid), facsimile transmission, or overnight express mail or courier service addressed as follows:

To Municipal:

To National Grid:

Village of Ilion, NY

Attn. Mayor Terry Leonard

Director, Transmission Commercial

49 Morgan Street

40 Sylvan Road

Ilion, NY 13357

Waltham, MA 02451

Fax: 315-894-6050

Fax: 781-907-5707

11.1.1 All notices required for billing purposes under this Agreement shall be in writing and shall be delivered to the following address:

To Municipal:

To National Grid:

Village of Ilion, NY

Attn. Mayor Terry Leonard

49 Morgan Street

Ilion, NY 13357

Fax: 315-894-6050

Director, Transmission Commercial

40 Sylvan Road

Waltham, MA 02451

Fax: 781-907-5707

- 11.1.2 If given by electronic transmission (including e-mail, facsimile or telecopy), notice shall be deemed given on the date received and shall be confirmed by a written copy sent by first class mail. If sent in writing by certified mail, notice shall be deemed given on the second business day following deposit in the United States mails, properly addressed, with postage prepaid. If sent by same-day or overnight delivery service, notice shall be deemed given on the day of delivery.
- 11.2 Either Party may change its address for notices without an amendment to this Agreement by notice to the other in the manner provided above.
- 11.3 Notwithstanding Section 11.1, any notice hereunder, with respect to an Emergency Condition or other occurrence requiring prompt attention, shall be communicated in an expedited manner and may be made by telephone provided that such notice is confirmed in writing promptly thereafter.

11.4 The representatives noted in Section 11.1, or their designees shall be authorized to act on behalf of the Parties, and their instructions, requests, and decisions will be binding upon the Parties as to all matters pertaining to this Agreement and the performance of the Parties hereunder. Only these representatives shall have the authority to commit funds or make binding obligations on behalf of the Parties. The Parties shall be permitted to change their respective representatives by providing notice to the other party of the change of representative.

ARTICLE XII TERM AND TERMINATION

- 12.1 This Agreement shall become effective as of the date first above written (the "EFFECTIVE DATE"), subject to its approval or acceptance for filing by the FERC (if applicable) or if filed unexecuted, upon the date specified by the FERC, and shall continue in effect for twenty (20) years thereafter.
- 12.2 This Agreement shall not merge with or be terminated or superseded by any future agreement between the Parties that does not specifically so provide.
- 12.3 In the event either National Grid or Municipal abandons its work or facilities under this Agreement; becomes insolvent; or assigns or sublets this Agreement in a manner inconsistent with this Agreement, or is violating any of the material conditions, terms, obligations, or covenants of this Agreement, or is not performing this Agreement in good faith, the other Party may terminate this Agreement by providing written notice. Before

instituting proceedings before FERC to terminate the Agreement, National Grid must give
Municipal written notice of the reasons for termination. If, within a period of ten (10)

Calendar Days of receiving such notice, Municipal or National Grid cures the default or breach cited by the other in such written notice, to the reasonable satisfaction of the Party that provided such notice, and shall have complied with the provisions of this Agreement, such notice shall become null and void and of no effect. Otherwise, such notice shall remain in effect and, except to the extent expressly provided for herein, the obligations of the Parties under this Agreement shall terminate ten (10) Calendar Days after such notice was provided.

12.4 In the event of a billing dispute between National Grid and Municipal, National Grid shall not remove the Interconnection Facilities or any part of the National Grid Transmission System from service or terminate transmission service thereon unless specifically authorized to do so under Applicable Laws and Regulations. Municipal shall not be in default under this Agreement as long as Municipal: (i) continues to make all payments and (ii) adheres to the dispute resolution procedures set forth in Article XXI of this Agreement and pays into an independent escrow account the portion of any invoice in dispute, pending resolution of such dispute. If Municipal fails to meet the foregoing two requirements, then a default shall be deemed to exist, to which appropriate procedures set forth in this Article XII shall apply.

12.5 Termination of this Agreement shall not relieve Municipal or National Grid of any of its liabilities and obligations arising hereunder prior to the date termination becomes effective, and Municipal or National Grid may take whatever judicial or administrative actions as

appear necessary or desirable to enforce its rights hereunder. The rights specified herein are not exclusive and shall be in addition to all other remedies available to either Party,

either at law or in equity, for default or breach of any provision of this Agreement; provided, however, that in no event shall National Grid or Municipal be liable for any incidental, special, indirect, exemplary or consequential costs, expenses, or damages sustained by the other, as provided for in Article XXII hereto.

12.6 If a Party provides to the other written notice of termination pursuant to Section 12.3 and, in accordance therewith, such notice remains in effect ten (10) Calendar Days after such notice was provided (thereby terminating the obligations of the Parties under this Agreement), the Party that received such notice shall be liable to the other for all costs, expenses, liabilities and obligations, including reasonable attorneys' fees, incurred by the other Party resulting from or relating to the termination of this Agreement.

12.7 In the event of termination of this Agreement without a superseding agreement governing the interconnection of Municipal and National Grid, National Grid, at its sole option, will physically disconnect Municipal from the National Grid Transmission System. National Grid may return the Transmission System to its original state prior to this Agreement, and remove any or all of National Grid Interconnection Facilities equipment. Municipal shall bear the costs of disconnecting any facilities solely used for the interconnection of Municipal to the National Grid Transmission System.

ARTICLE XIII FORCE MAJEURE

13.1 Economic hardship is not considered a Force Majeure event.

13.2 Neither Party shall be considered to be in default or breach hereunder, and shall be excused from performance hereunder, if and to the extent that it shall be delayed in or

prevented from performing or carrying out any provisions of this Agreement by reason of flood, lightning strikes, earthquake, fire, epidemic, war, act of terrorism as confirmed by a Governmental Authority having jurisdiction, invasion, riot, civil disturbance, sabotage, explosion, insurrection, military or usurped power, strikes, stoppage of labor, labor dispute, failure of contractors or supplies of material, action of any court or Governmental Authority, or any civil or military authority de facto or de jure, change in law, act of God or the public enemy, or any other event or cause beyond such Party's control, including, without limitation, disconnection or limited operation of National Grid's electric system, unscheduled repairs or maintenance or equipment breakdown resulting even with Good Utility Practice which are beyond such Party's reasonable control; provided, however, that neither Party may claim Force Majeure for any delay or failure to perform or carry out any provision of this Agreement to the extent that such Party has been negligent or engaged in intentional misconduct and such negligence or misconduct contributed to that Party's delay or failure to perform or carry out its duties and obligations under this Agreement.

- 13.3 The Party claiming force majeure shall give notice to the other Party of the occurrence of Force Majeure no later than ten (10) Business Days after such occurrence and shall use due diligence to resume performance or the provision of service hereunder as soon as practicable.

ARTICLE XIV INDEMNIFICATION

14.1 To the fullest extent allowed by law and subject to the other terms and conditions of this Agreement, each Party (the “*Indemnifying Party*”) shall indemnify, defend, and

save harmless the other Party, its affiliates and its and its affiliates' officers, directors and employees (each, individually, an "*Indemnified Party*" and, collectively, the "*Indemnified Parties*"), from and against any losses, damages, claims, including claims and actions relating to injury to or death of any person or damage to property, liabilities, injuries, costs, suits, causes of action, charges, expenses, reasonable attorneys' fees, and all other liabilities by or to third parties ("*Damages*"), to the extent caused by or arising out of (i) any breach of this Agreement by the Indemnifying Party, or (ii) any negligence, willful misconduct or breach of applicable law by the Indemnifying Party in connection with this Agreement, except to the extent such Damages are the result of any Indemnified Party's gross negligence, willful misconduct or breach of this Agreement or of applicable law. The foregoing notwithstanding, each Party shall be and remain solely responsible for all claims of the Party's own employees arising out of any provision of the Workers' Compensation Law.

- 14.2 The Indemnifying Party shall take prompt action to defend and indemnify the Indemnified Party(ies) pursuant to Section 14.1 against claims, actual or threatened, but in no event later than notice by the Indemnified Party to the Indemnifying Party of the service of notice, summons, complaint, petition or other service of process alleging damage, injury, liability, or expense that may be subject to indemnification hereunder. The Indemnifying Party shall defend any such claim or threatened claim, including, as applicable, engagement of legal counsel reasonably acceptable to the Indemnified Party, to respond to, defend, settle, or compromise any such claim or threatened claim. The Indemnifying Party shall not

agree to any settlement that would impose any liability whatsoever on any Indemnified
Party.

- 14.3 Furthermore, the Indemnifying Party understands and agrees it is responsible for any and all costs and expenses incurred by the Indemnified Party to enforce this Article.
- 14.4 The obligations set forth in this Article shall survive the later of the completion of the work, termination or expiration of the Agreement.

**ARTICLE XV
RELATIONSHIP OF THE PARTIES**

- 15.1 Nothing contained in this Agreement shall be construed or deemed to cause, create, constitute, give effect to, or otherwise recognize Municipal and National Grid to be partners, joint venturers, employer and employee, principal and agent, or any other business association, with respect to any matter.
- 15.2 Unless otherwise agreed to in writing signed by both Parties, neither Party shall have any authority to create or assume in the other Party's name or on its behalf any obligation, express or implied, or to act or purport to act as the other Party's agent or legal empowered representative for any purpose whatsoever.
- 15.3 Neither Party shall be liable to any third party in any way for any engagement, obligation, commitment, contract, representation or for any negligent act or omission of the other Party, except as expressly provided for herein.
- 15.4 The rights and obligations of the Parties shall be limited to those expressly set forth herein.

**ARTICLE XVI
THIRD PARTY BENEFICIARY/ASSIGNMENT**

- 16.1 No person or party shall have any rights or interests, direct or indirect, in this

Agreement or the services or facilities to be provided hereunder, or both, except the Parties, their successors, and authorized assigns.

16.2 The Parties specifically disclaim any intent to create any rights in any person or party as a third-party beneficiary to this Agreement.

16.3 Except as provided for in Sections 16.3.1, 16.3.2 and 16.3.3, neither Party may assign this Agreement or any of its rights, interests, or obligations hereunder without the prior written consent of the other Party, which such consent shall not be unreasonably withheld.

16.3.1 Municipal may, with only prior written notice to National Grid, assign, transfer, pledge, or otherwise dispose of its rights and interests under this Agreement to any lender or financial institution in connection with the financing or refinancing of the Municipal Interconnection Facilities or property acquisition therefore.

16.3.2 National Grid may, with only prior written notice to Municipal, assign, transfer, pledge, or otherwise dispose of National Grid's rights and interests under this Agreement to any lender or financial institution in connection with the financing or refinancing of the Transmission System or property acquisition therefor.

16.3.3 Any company or entity which succeeds by purchase, merger or consolidation of the properties and assets, substantially or entirely, of National Grid or Municipal shall be entitled to the rights and shall be subject to the obligations of National Grid or Municipal under this Agreement.

16.4 Each Party agrees to reimburse the other Party for any costs and expenses (including

reasonable attorneys' fees) incurred in connection with the other Party's review, execution and delivery of instruments, agreements or documents necessary in connection with the assigning Party's assignment, transfer, sale or other disposition of this Agreement or any interest in the Interconnection Facilities or the National Grid Transmission System.

- 16.5 Any assignment in violation of Article XVI shall be considered null and void from its inception and National Grid reserves the right to proceed with a regulatory or judicial resolution regarding the continued operation of the Interconnection Facilities.
- 16.6 Any authorized assignment shall not relieve the assigning Party of the responsibility of full compliance with the requirements of this Agreement, unless the other Party consents and the assignee agrees in writing to be bound by all of the obligations and duties of the assigning Party provided for in this Agreement and has provided written assurances to the other Party of continued performance and protection against liability upon assignment.
- 16.7 Assignment contrary to the provisions of this Agreement shall make the assigning Party the indemnitor of the other Party and its successors against any liabilities and costs, including attorneys' fees as to which the assigning Party's transferee fails to indemnify, defend, and hold harmless the other Party, its agents, employees and its successors, from and against any loss, damage, liability, cost, suit, charge, expense (including reasonable attorney's fees) or cause of action, incurred by the other Party as a result of said assignment or as a result of any dispute between the assigning Party and its transferees, or between any subsequent transferees, that arises from or relates to any assignment by the assigning Party.

16.8 This Agreement shall bind and inure to the benefit of the Parties to this Agreement, their successors and permitted assigns.

**ARTICLE XVII
APPROVAL**

17.1 National Grid shall file this Agreement with the appropriate regulatory authorities. If any such regulatory body materially modifies the terms and conditions of this Agreement and such modification(s) materially affect the benefits flowing to one or both of the Parties, the Parties agree to attempt in good faith to negotiate an amendment or amendments to this Agreement or take other appropriate action(s) so as to put each Party in effectively the same position in which the Parties would have been had such modification not been made. In the event that, within sixty (60) Calendar Days or some other time period mutually agreed upon by the Parties after such modification has been made, the Parties are unable to reach agreement as to what, if any, amendments are necessary and fail to take other appropriate action to put each Party in effectively the same position in which the Parties would have been had such modification not been made, then either Party shall have the right to unilaterally terminate this Agreement.

**ARTICLE XVIII
WAIVER**

18.1 No provision of this Agreement may be waived except by mutual agreement of the Parties as expressed in writing and signed by both Parties.

18.2 Any waiver that is not in writing and signed by both Parties shall be null and void from its inception.

- 18.3 No express waiver in any specific instance as provided in a required writing shall be construed as a waiver of future instances unless specifically so provided in the required writing.
- 18.4 No express waiver of any specific default shall be deemed a waiver of any other default whether or not similar to the default waived, or a continuing waiver of any other right or default by a Party.
- 18.5 The failure of either Party to insist in any one or more instances upon the strict performance of any of the provisions of this Agreement, or to exercise any right herein, shall not be construed as a waiver or relinquishment for the future of such strict performance of such provision or the exercise of such right.

**ARTICLE XIX
AMENDMENT AND MODIFICATION**

- 19.1 This Agreement may be amended or modified if the amendment or modification is in writing and executed by both Parties.
- 19.2 No express amendment or modification in any specific instance as provided herein shall be construed as an amendment or modification of future instances, unless specifically so provided in the required writing.
- 19.3 Except as provided for in Section 10.5, nothing in this Agreement shall be construed as affecting in any way the right of National Grid to unilaterally make application to FERC (or any successor agency) for a change in rates, terms and conditions, charges, classifications of service, rule or regulation under Section 205, of the Federal Power Act and pursuant to

FERC's rules and regulations promulgated thereunder.

**ARTICLE XX
GOVERNING LAW**

- 20.1 This Agreement and the rights and obligations of the Parties to this Agreement shall be governed by and construed in accordance with the laws of the State of New York, without giving effect to the conflict of laws principles thereof.
- 20.2 Municipal and National Grid agree that National Grid shall file this Agreement with FERC for approval under the Federal Power Act, provided that nothing in this Agreement shall cause Municipal to become subject to the jurisdiction of FERC.
- 20.3 Municipal and National Grid waive personal service by manual delivery and agree that service of process on Municipal or National Grid in any action concerning or arising out of this Agreement may be made by registered or certified mail, return receipt requested, delivered to Municipal or National Grid at the addresses set forth in Article XI of this Agreement.
- 20.4 This Agreement is subject to all Applicable Laws and Regulations.
- 20.5 Each Party expressly reserves the right to seek changes in, appeal, or otherwise contest any laws, orders, rules, or regulations of a Governmental Authority.
- 20.6 Subject to the procedures of Article XXI, each Party reserves all rights under Applicable Laws and Regulations to raise issues and disputes related to this Agreement in the appropriate legal and/or regulatory forum.

ARTICLE XXI

DISPUTE RESOLUTION

- 21.1 Should a claim or dispute among the Parties arise under this Agreement, the Parties shall continue, in good faith, to perform their respective obligations hereunder. Notice of any claim or dispute that any Party may have against another Party, arising out of the Agreement shall be submitted in writing to the other Parties in a manner that clearly identifies the nature of the claim or dispute and requests that the Parties engage in negotiations to resolve the claim or dispute.
- 21.2 Upon receipt of the notice of claim or dispute under Section 21.1, the Parties shall use Reasonable Efforts to resolve any such dispute without resorting to judicial resolution, through good faith negotiations between representatives with authority to resolve or settle the claim or dispute. The Parties agree to keep confidential any documents or materials exchanged and/or confidential information revealed in furtherance of resolving or settling the claim or dispute under this Article XXI of this Agreement and that such documents, materials, or information shall be considered confidential settlement information and that, pursuant to Rule 408 of the Federal Rules of Evidence and parallel doctrines of state law, shall not be admissible as evidence in any subsequent judicial or regulatory proceeding.
- 21.3 If the dispute remains unresolved for more than sixty (60) Calendar Days after receipt of the notice of claim or dispute under Section 21.1, any Party may seek resolution of its rights and remedies under this Agreement through any available forum in accordance with this Article XXI.

ARTICLE XXII LIMITATION OF LIABILITY

22.1 Notwithstanding any other provision of this Agreement, neither Party shall be

responsible to the other Party or to any Indemnified Party for any incidental, indirect, exemplary, multiple, punitive, special or consequential damages (including, without limitation, loss of profits) in connection with this Agreement, including, without limitation, damage claims based on causes of action for breach of contract, tort (including negligence), or any other theory of recovery, whether or not (i) such damages were reasonably foreseeable or (ii) the Parties were advised or aware that such damages might be incurred.

Anything in this Agreement to the contrary notwithstanding, if any Party's liability in connection with this Agreement is limited or capped pursuant to any applicable law, statute, ordinance, rule or regulation, then the other Party hereto shall be entitled to elect an identical liability limitation and/or cap as if such law, statute, ordinance, rule or regulation were applicable to such Party.

22.2 **[Not Used]**

22.3 **Survival.** The provisions of this Article shall apply regardless of fault and shall survive termination, cancellation, suspension, completion or expiration of this Agreement.

ARTICLE XXIII CONFIDENTIALITY

23.1 **Confidentiality.** Certain information exchanged by the Parties during the term of this Agreement shall constitute confidential information ("Confidential Information") and shall be subject to this Article XXIII.

If requested by a Party receiving information, the Party supplying the information shall provide in writing, the basis for asserting that the information referred to in this Article warrants confidential treatment, and the requesting Party may disclose

such writing to the appropriate Governmental Authority. Each Party shall be responsible for the costs associated with affording confidential treatment to its information.

23.1.1 Term. During the term of this Agreement, and for a period of three (3) years after the expiration or termination of this Agreement, except as otherwise provided in this Article XXIII, each Party shall hold in confidence and shall not disclose to any person Confidential Information.

23.1.2 Confidential Information. The following shall constitute Confidential Information: (1) any non-public information that is treated as confidential by the disclosing Party and which the disclosing Party identifies as Confidential Information in writing at the time, or promptly after the time, of disclosure; or (2) information designated as Confidential Information by the NYISO Code of Conduct contained in Attachment F to the NYISO OATT.

23.1.3 Scope. Confidential Information shall not include information that the receiving Party can demonstrate: (1) is generally available to the public other than as a result of a disclosure by the receiving Party; (2) was in the lawful possession of the receiving Party on a non-confidential basis before receiving it from the disclosing Party; (3) was supplied to the receiving Party without restriction by a third party, who, to the knowledge of the receiving Party after due inquiry, was under no obligation to the disclosing Party to keep such information confidential; (4) was independently developed by the receiving

Party without reference to Confidential Information of the disclosing Party; (5) is, or becomes, publicly known, through no wrongful act or omission of the receiving Party or Breach of this Agreement; or (6) is required, in accordance with Section 23.1.8 of this Agreement, Order of Disclosure, to be disclosed by any Governmental Authority or is otherwise required to be disclosed by law or subpoena, or is necessary in any legal proceeding establishing rights and obligations under this Agreement. Information designated as Confidential Information will no longer be deemed confidential if the Party that designated the information as confidential notifies the other Party that it no longer is confidential.

23.1.4 Release of Confidential Information. No Party shall release or disclose Confidential Information to any other person, except to its Affiliates (limited by FERC Standards of Conduct requirements), subcontractors, employees, consultants, or to parties who may be or considering providing financing to or equity participation with Municipal, or to potential purchasers or assignees of a Party, on a need-to-know basis in connection with this Agreement, unless such person has first been advised of the confidentiality provisions of this Article XXIII and has agreed to comply with such provisions. Notwithstanding the foregoing, a Party providing Confidential Information to any person shall remain primarily responsible for any release of Confidential Information in contravention of this Article XXIII.

23.1.5 Rights. Each Party retains all rights, title, and interest in the Confidential

Information that each Party discloses to the other Party. The disclosure by each Party to the other Parties of Confidential Information shall not be deemed a waiver by any Party or any other person or entity of the right to protect the Confidential Information from public disclosure.

23.1.6 **No Warranties.** By providing Confidential Information, no Party makes any warranties or representations as to its accuracy or completeness. In addition, by supplying Confidential Information, no Party obligates itself to provide any particular information or Confidential Information to the other Parties nor to enter into any further agreements or proceed with any other relationship or joint venture.

23.1.7 **Standard of Care.** Each Party shall use at least the same standard of care to protect Confidential Information it receives as it uses to protect its own Confidential Information from unauthorized disclosure, publication or dissemination. Each Party may use Confidential Information solely to fulfill its obligations to the other Party under this Agreement or its regulatory requirements, including the NYISO OATT and NYISO Services Tariff.

23.1.8 **Order of Disclosure.** If a court or a Government Authority or entity with the right, power, and apparent authority to do so requests or requires any Party, by subpoena, oral deposition, interrogatories, requests for production of documents, administrative order, or otherwise, to disclose Confidential

Information, that Party shall provide the other Parties with prompt notice of such request(s) or requirement(s) so that the other Parties may seek an

appropriate protective order or waive compliance with the terms of this Agreement. Notwithstanding the absence of a protective order or waiver, the Party may disclose such Confidential Information which, in the opinion of its counsel, the Party is legally compelled to disclose. Each Party will use Reasonable Efforts to obtain reliable assurance that confidential treatment will be accorded any Confidential Information so furnished.

23.1.9 Termination of Agreement. Upon termination of this Agreement for any reason, each Party shall, within ten (10) Calendar Days of receipt of a written request from the other Parties, use Reasonable Efforts to destroy, erase, or delete (with such destruction, erasure, and deletion certified in writing to the other Parties) or return to the other Parties, without retaining copies thereof, any and all written or electronic Confidential Information received from the other Parties pursuant to this Agreement.

23.1.10 Remedies. The Parties agree that monetary damages would be inadequate to compensate a Party for another Party's Breach of its obligations under this Article XXIII. Each Party accordingly agrees that the other Parties shall be entitled to equitable relief, by way of injunction or otherwise, if the first Party Breaches or threatens to Breach its obligations under this Article XXIII, which equitable relief shall be granted without bond or proof of damages, and the receiving Party shall not plead in defense that there would be an adequate remedy at

law. Such remedy shall not be deemed an exclusive remedy for the Breach of this Article XXIII, but shall be in addition to all other remedies available at law or in

equity. The Parties further acknowledge and agree that the covenants contained herein are necessary for the protection of legitimate business interests and are reasonable in scope. No Party, however, shall be liable for indirect, incidental, or consequential or punitive damages of any nature or kind resulting from or arising in connection with this Article XXIII.

23.1.11 Disclosure to FERC, its Staff, or a State. Notwithstanding anything in this Article XXIII to the contrary, and pursuant to 18 C.F.R. section Ib.20, if FERC or its staff, during the course of an investigation or otherwise, requests information from one of the Parties that is otherwise required to be maintained in confidence pursuant to this Agreement or the NYISO OATT, the Party shall provide the requested information to FERC or its staff, within the time provided for in the request for information. In providing the information to FERC or its staff, the Party must, consistent with 18 C.F.R. section 388.112, request that the information be treated as confidential and non-public by FERC and its staff and that the information be withheld from public disclosure. Parties are prohibited from notifying the other Parties to this Agreement prior to the release of the Confidential Information to the Commission or its staff. The Party shall notify the other Parties to the Agreement when it is notified by FERC or its staff that a request to release Confidential Information has been received by FERC, at which time the Parties may respond before such information would be made public, pursuant to 18 C.F.R. section 388.112. Requests from a state regulatory

body conducting a confidential investigation shall be treated in a similar manner if consistent with the applicable state rules and regulations. A Party shall not be

liable for any losses, consequential or otherwise, resulting from that Party divulging Confidential Information pursuant to a FERC or state regulatory body request under this paragraph.

23.1.12 Except as otherwise expressly provided herein, no Party shall disclose

Confidential Information to any person not employed or retained by the Party possessing the Confidential Information, except to the extent disclosure is (i) required by law; (ii) reasonably deemed by the disclosing Party to be required to be disclosed in connection with a dispute between or among the Parties, or the defense of litigation or dispute; (iii) otherwise permitted by consent of the other Party, such consent not to be unreasonably withheld; or (iv) necessary to fulfill its obligations under this Agreement, the NYISO OATT or the NYISO Services Tariff. Prior to any disclosures of a Party's Confidential Information under this subparagraph, or if any third party or Governmental Authority makes any request or demand for any of the information described in this subparagraph, the disclosing Party agrees to promptly notify the other Party in writing and agrees to assert confidentiality and cooperate with the other Party in seeking to protect the Confidential Information from public disclosure by confidentiality agreement, protective order or other reasonable measures.

ARTICLE XXIV SEVERABILITY

24.1 If any term of this Agreement, or the interpretation or application of any term or provision to any prior circumstance, is held to be unenforceable, illegal, or invalid by any

governmental agency or court of competent jurisdiction, the remainder of this Agreement,

or the interpretation or application of all other terms or provisions to persons or circumstances other than those that are unenforceable, illegal, or invalid, shall not be affected thereby and each term and provision shall be valid and be enforced to the fullest extent permitted by law.

ARTICLE XXV HEADINGS

- 25.1 The headings in this Agreement are included herein for convenience of reference only and shall not constitute a part of this Agreement for any other purpose, or limit or be used as an aid in construing the provisions of this Agreement.

ARTICLE XXVI INFORMATION ACCESS AND AUDIT RIGHTS

- 26.1 **Information Access.** Each Party (“Disclosing Party”) shall make available to another Party (“Requesting Party”) information that is in the possession of the Disclosing Party and is necessary in order for the Requesting Party to: (i) verify the costs incurred by the Disclosing Party for which the Requesting Party is responsible under this Agreement; and (ii) carry out its obligations and responsibilities under this Agreement. The Parties shall not use such information for purposes other than those set forth in this Section 26.1 of this Agreement and to enforce their rights under this Agreement.
- 26.2 **Reporting of Non-Force Majeure Events.** Each Party (the “Notifying Party”) shall notify the other Parties when the Notifying Party becomes aware of its inability to comply with the provisions of this Agreement for a reason other than a Force Majeure event. The Parties agree to cooperate with each other and provide necessary information

regarding such inability to comply, including the date, duration, reason for the inability to comply, and corrective actions taken or planned to be taken with respect to such inability

to comply. Notwithstanding the foregoing, notification, cooperation or information provided under this Article shall not entitle the Party receiving such notification to allege a cause for anticipatory breach of this Agreement.

26.3 Audit Rights. Subject to the requirements of confidentiality under Article XXIII of this Agreement, each Party shall have the right, during normal business hours, and upon prior reasonable notice to another Party, to audit at its own expense the other Party's accounts and records pertaining to the other Party's performance or satisfaction of its obligations under this Agreement. Such audit rights shall include audits of the other Party's costs, calculation of invoiced amounts, and each Party's actions in an Emergency Condition. Any audit authorized by this Article shall be performed at the offices where such accounts and records are maintained and shall be limited to those portions of such accounts and records that relate to the Party's performance and satisfaction of obligations under this Agreement. Each Party shall keep such accounts and records for a period equivalent to the audit rights periods described in Section 26.4 of this Agreement.

26.4 Audit Rights Periods.

26.4.1 Audit Rights Period for Construction-Related Accounts and Records.

Accounts and records related to the design, engineering, procurement, and construction of Interconnection Facilities and Upgrades shall be subject to audit for a period of twenty-four months following National Grid's issuance of a final invoice concerning these Interconnection Facilities and Upgrades.

26.4.2 Audit Rights Period for All Other Accounts and Records. Accounts and

records related to a Party's performance or satisfaction of its obligations under

this Agreement other than those described in Section 26.4.1 of this Agreement shall be subject to audit as follows: (i) for an audit relating to cost obligations, the applicable audit rights period shall be twenty-four months after the auditing Party's receipt of an invoice giving rise to such cost obligations; and (ii) for an audit relating to all other obligations, the applicable audit rights period shall be twenty-four months after the event for which the audit is sought.

26.5 **Audit Results.** If an audit by a Party determines that an overpayment or an underpayment has occurred, a notice of such overpayment or underpayment shall be given to the other Party together with those records from the audit which support such determination.

ARTICLE XXVII. SUBCONTRACTORS

27.1 **General.** Nothing in this Agreement shall prevent a Party from utilizing the services of any subcontractor as it deems appropriate to perform its obligations under this Agreement; provided, however, that each Party shall require its subcontractors to comply with all applicable terms and conditions of this Agreement in providing such services and each Party shall remain primarily liable to the other Parties for the performance of such subcontractor.

27.2 **Responsibility of Principal.** The creation of any subcontract relationship shall not relieve the hiring Party of any of its obligations under this Agreement. The hiring Party shall be fully responsible to the other Parties for the acts or omissions of any subcontractor the hiring Party hires as if no subcontract had been made; provided,

however, that in no event shall National Grid be liable for the actions or inactions of the Municipal or its subcontractors with respect to obligations of the Municipal related to the construction of Interconnection Facilities. Any applicable obligation imposed by this Agreement upon the hiring Party shall be equally binding upon, and shall be construed as having application to, any subcontractor of such Party.

- 27.3 **No Limitation by Insurance.** The obligations under this Article XXVII will not be limited in any way by any limitation of subcontractor's insurance.

ARTICLE XXVIII COMPLIANCE WITH GOOD UTILITY PRACTICE

- 28.1 The Parties shall comply with Good Utility Practice.

ARTICLE XXIX COUNTERPARTS

- 29.1 This Agreement may be executed in two or more counterparts, each of which shall be deemed an original but all of which together shall constitute one and the same instrument.

ARTICLE XXX MISCELLANEOUS

- 30.1 **Binding Effect.** This Agreement and the rights and obligations hereof, shall be binding upon and shall inure to the benefit of the successors and permitted assigns of the Parties hereto.

- 30.2 **Conflicts.** If there is a discrepancy or conflict between or among the terms and

conditions of this cover agreement and the Appendices hereto, the terms and conditions of this cover agreement shall be given precedence over the Appendices, except as

otherwise expressly agreed to in writing by the Parties.

30.3 **Rules of Interpretation.** This Agreement, unless a clear contrary intention appears, shall be construed and interpreted as follows: (1) the singular number includes the plural number and vice versa; (2) reference to any person includes such person's successors and assigns but, in the case of a Party, only if such successors and assigns are permitted by this Agreement, and reference to a person in a particular capacity excludes such person in any other capacity or individually; (3) reference to any agreement (including this Agreement), document, instrument or tariff means such agreement, document, instrument, or tariff as amended or modified and in effect from time to time in accordance with the terms thereof and, if applicable, the terms hereof; (4) reference to any Applicable Laws and Regulations means such Applicable Laws and Regulations as amended, modified, codified, or reenacted, in whole or in part, and in effect from time to time, including, if applicable, rules and regulations promulgated thereunder; (5) unless expressly stated otherwise, reference to any Article, Section or Appendix means such Article of this Agreement or such Appendix to this Agreement; (6) "hereunder", "hereof", "herein", "hereto" and words of similar import shall be deemed references to this Agreement as a whole and not to any particular Article or other provision hereof or thereof; (7) "including" (and with correlative meaning "include") means including without limiting the generality of any description preceding such term; and (8) relative to the determination of any period of time, "from" means "from and including", "to" means "to but excluding" and "through" means "through and including".

30.4 **Compliance.** Each Party shall perform its obligations under this Agreement in

accordance with Applicable Laws and Regulations, Applicable Reliability Standards, the NYISO OATT and Good Utility Practice. To the extent a Party is required or prevented or limited in taking any action by such regulations and standards, such Party shall not be deemed to be in Breach of this Agreement for its compliance therewith. When any Party becomes aware of such a situation, it shall notify the other Parties promptly so that the Parties can discuss the amendment to this Agreement that is appropriate under the circumstances.

30.5 **Entire Agreement.** This Agreement, including all Appendices, Attachments, Exhibits and Schedules attached hereto, constitutes the entire agreement between the Parties with reference to the subject matter hereof, and supersedes all prior and contemporaneous understandings or agreements, oral or written, between the Parties with respect to the subject matter of this Agreement. There are no other agreements, representations, warranties, or covenants which constitute any part of the consideration for, or any condition to, either Party's compliance with its obligations under this Agreement.

IN WITNESS WHEREOF, the Parties hereto have caused this instrument to be executed as of the
National Grid
day and year first above written.

By: 

Title: Authorized Representative

Date: March 28, 2018

Village of Ilion _____

By: 

Title: 117 4709

Date: 3/15/18

Exhibit A

Delivery Point #1

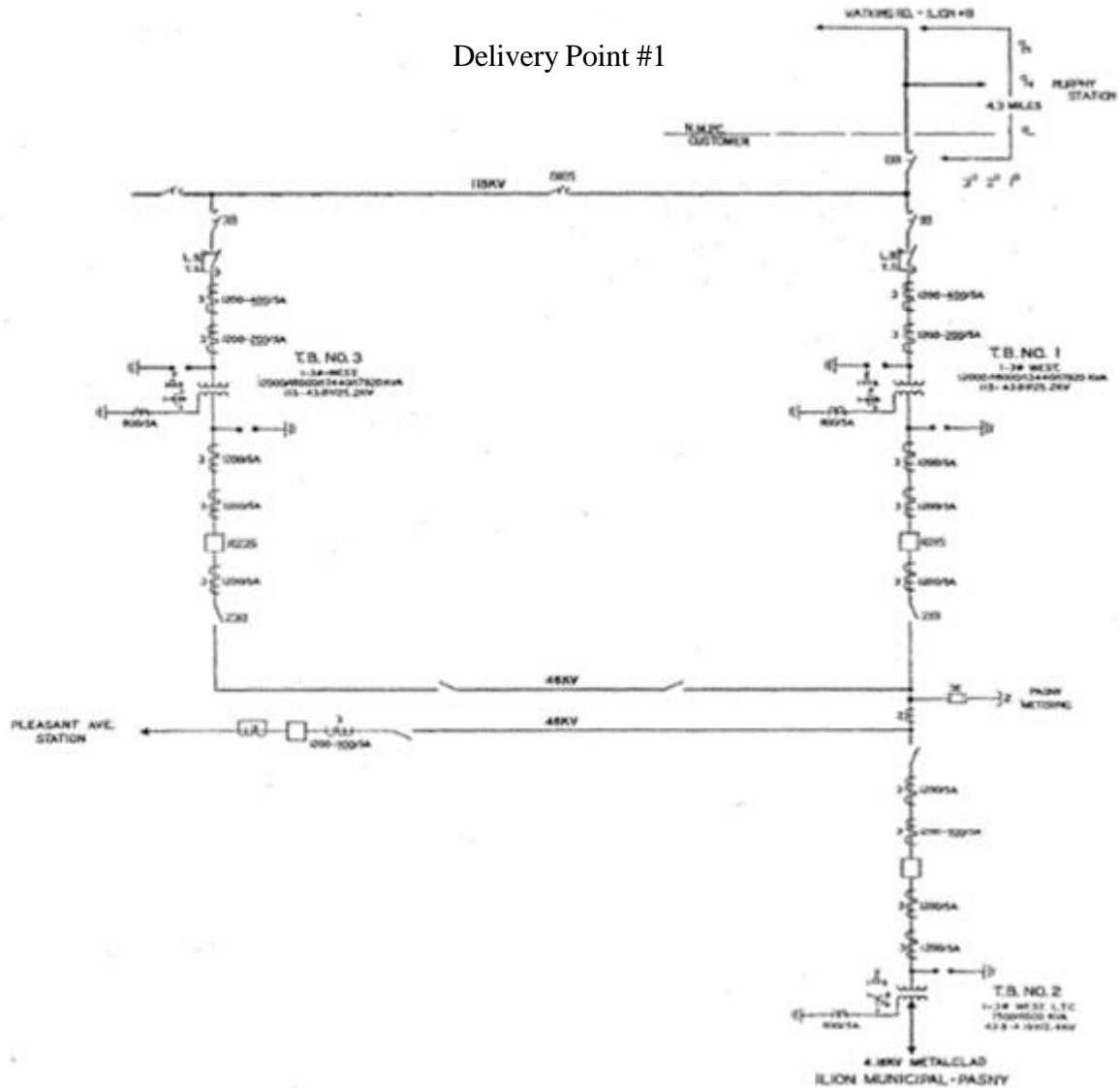

National Grid owns and operates the 115kV transmission line, Watkins Rd. - Ilion No. 8, connected to the Watkins Road Station. This approximate 4.3-mile overhead line on wood pole structures terminates on the Village of Ilion’s receiving structure in the Ilion Municipal Substation. This includes the dead-end insulators and conductor connections from the line to the Village’s 115kV main disconnect switch No. 88. Watkins Rd. Station is the Transmission Interconnection Point for the Ilion Municipal Substation.

The Village of Iliion owns, operates, and maintains a 115kV-46kV-4.16kV distribution substation receiving 115kV delivery from National Grid's 115kV Watkins Rd. - Iliion No. 8 transmission line. The Village's substation is known as "Iliion Municipal". This substation has a main 115Kv disconnect switch at the demarcation point, No. 88 and is the Point of Change of Ownership at the line side of the switch. It connects to a 115kV closed tie bus that supplies circuit switchers Nos. 18 and 38. These circuit switchers provide the high voltage side protection for the Village's two main 115kV delta - 43.8Y/25.2kV, 12MVA transformers Nos. 1 and 3. NYPA is the metering authority and their metering equipment is located on the 43.8kV side of the Village's main transformers protected by 43.8kV circuit breakers Nos. R215 and R235. This metering is compensated for the transformer losses to 115kV delivery. The Village then supplies two feeders at 43.8kV. These circuits supply the Village's Pleasant Ave. substation facility and the 43.8kV delta - 4.16Y/2.4kV, 7.5MVA main distribution transformer No. 2. Transformer No. 2 in Iliion Municipal supplies the Village's 4.16Y/2.4kV distribution electric power system (EPS).

Delivery Point #2

Remington shall switch from taking electric service from National Grid to taking service from Municipal. National Grid shall establish a second 46kV delivery point for Municipal at Remington's location through Municipal ownership of Remington's existing 46-4.16kV substation, including the 4.16kV feeder to Remington's main 4.16kV switchgear. Present revenue metering is on the 4.16kV side of the transformer and is compensated for transformer losses to 46kV delivery

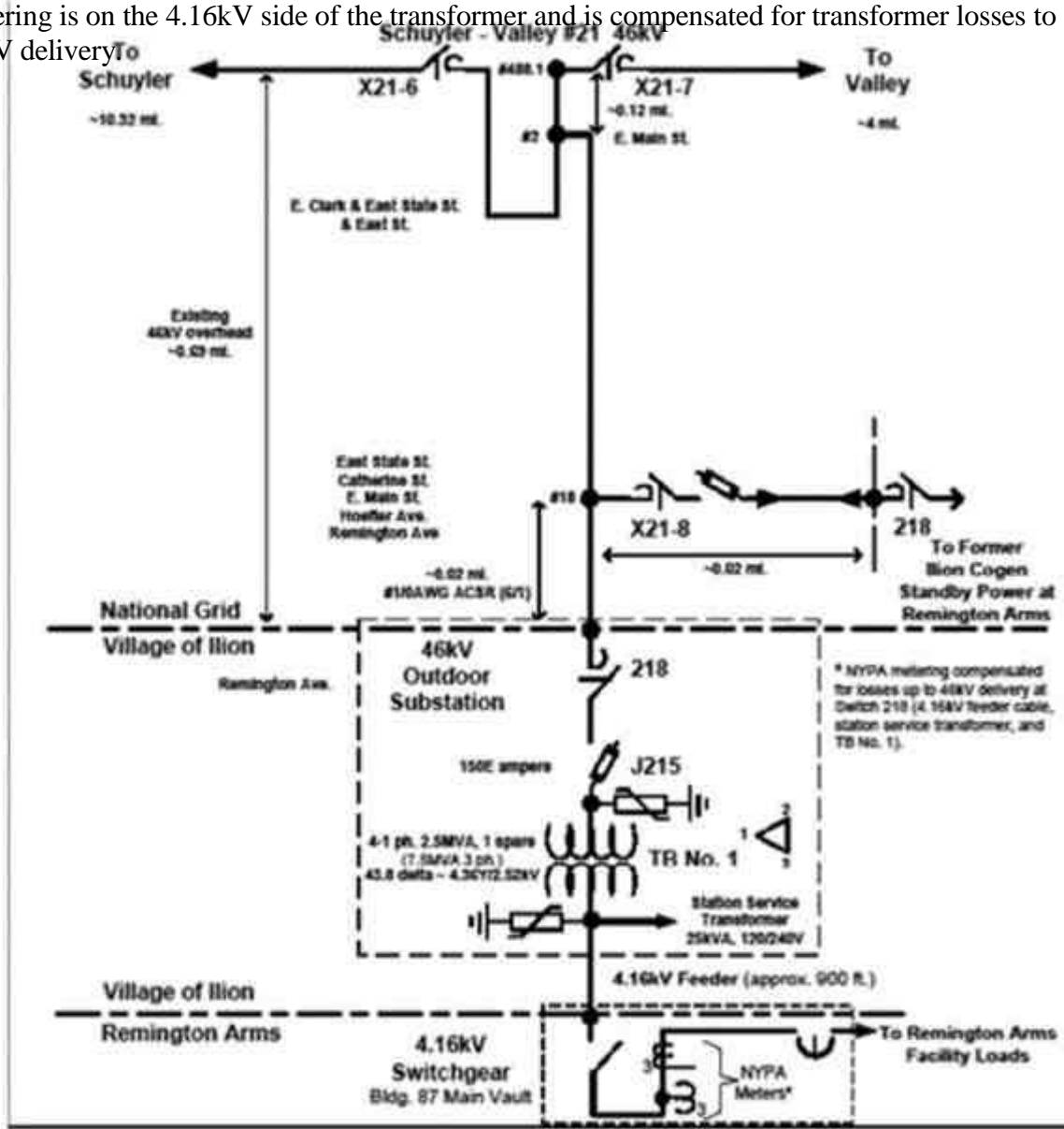

The Transmission Interconnection Point is located at the point where the 46kV tap line serving the Village of Ilion substation interconnects with the Schuyler - Valley #21 line between Switches X21-6 and X21-7 that are integral with National Grid's 46kV EPS.

National Grid Interconnection Facilities include all facilities and equipment from the Transmission Interconnection Point to the high side of the 218 switch located in the Village of Ilion Substation on Remington Ave.

The change of ownership point is the line side of the 218 switch located in the Village of Ilion Substation on Remington Ave. The 218 switch is owned by the Municipal as identified on the one line diagram for Delivery Point #2 in Exhibit A.

Municipal Interconnection Facilities include all facilities and equipment located on the load side of the 218 switch located in the Village of Ilion Substation on Remington Ave. Remington has had a maximum 8.244MW demand. This demand is within the National Grid's summer normal rating of the 46kV EPS' capability. If the Village, after taking ownership of

Remington's substation and the 4.16kV feeder to Remington's main 4.16kV switchgear, proposes to exceed this limit at any time in the future, then the Company needs to evaluate the Village's request.

The existing secondary side 4.16kV metering transformers (remaining-in-place and to be sold to the Village) are planned for the Village's NYPA metering purposes. NYPA will compensate for the Village's transformer losses, station service transformer (25kVA) usage, and 4.16kV feeder (approx.900 ft.) cable losses to the 46kV delivery point at the Village's substation receiving structure.

[One-Line Diagram]

[Description/List of National Grid Interconnection Facilities]

[Description/List of Municipal Interconnection Facilities]

Exhibit B

Existing Facility - No Study

Exhibit C

Electric System Bulletin No. 752, as it may be updated from time to time.

A current copy of Electric System Bulletin No. 752 can be found at the following link:

http://www.nationalgridus.com/niagaramohawk/construction/3_elec_specs.asp