

Attachment A

AMENDED

COST REIMBURSEMENT AGREEMENT

Between

**NIAGARA MOHAWK POWER CORPORATION
d/b/a/ National Grid**

and

NEW YORK POWER AUTHORITY

(NYISO OATT Service Agreement No. 2177)

COST REIMBURSEMENT AGREEMENT

THIS COST REIMBURSEMENT AGREEMENT (the "Agreement"), made and entered into as of this November [___], 2014 (the "Effective Date"), by and between the **NEW YORK POWER AUTHORITY**, having an office and place of business at 123 Main Street, White Plains, New York 10601 (the "Customer"), and **NIAGARA MOHAWK POWER CORPORATION**, a corporation organized and existing under the laws of the State of New York, having an office and place of business at 300 Erie Boulevard West, Syracuse, New York 13202 (the "Company"). Customer and Company may be referred to hereunder, individually, as a "Party" or, collectively, as the "Parties".

WITNESSETH

WHEREAS, Customer is planning to install new Series Compensation Equipment (the "Project") on the existing Edic –Frazier 345 kV transmission line; and

WHEREAS, Customer has undertaken a study of adjoining transmission facilities and has identified equipment on Company's transmission system that will require the Company to engineer, design, procure, construct, test and commission replacements or up-grades as part of the Project; and

WHEREAS, Customer shall be responsible for all costs arising from such engineering, design, procurement, construction, testing and commissioning; and

WHEREAS, all such construction, testing and commissioning shall be performed solely on Company facilities and property and Company shall own and operate such replacements and up-grades on Company's transmission system as described in this Agreement; and

WHEREAS, the Company is willing to perform these requested replacements and upgrades to its equipment, subject to the terms and conditions of this Agreement;

NOW, THEREFORE, in consideration of the premises and the mutual covenants set forth herein, the Parties agree as follows:

1.0 Definitions

Wherever used in this Agreement with initial capitalization, whether in the singular or the plural, these terms shall have the following meanings:

"Agreement" means this Cost Reimbursement Agreement including all annexes, appendices, attachments, schedules and exhibits and any subsequent amendments, supplements, or modifications thereto, as mutually agreed to and executed by the Parties in accordance with the terms of this Agreement.

“Company Reimbursable Costs” means the actual costs and expenses incurred by Company and/or its affiliates in connection with performance of the Work (as defined below) or otherwise incurred by Company and/or its affiliates in connection with the Project (as defined below) or this Agreement. Without limiting the foregoing, these Company Reimbursable Costs shall include the actual expenses for labor (including internal labor), services, materials, subcontracts, equipment or other expenses incurred in the execution of the Work or otherwise in connection with the Project, all applicable overhead, all federal, state and local taxes incurred (including all applicable taxes arising from amounts paid to Company that are determined to be contributions in aid of construction), all costs of outside experts, consultants, counsel and contractors, all other third-party fees and costs, and all costs of obtaining any required consents, releases, approvals, or authorizations, including the Required Regulatory Approvals.

“Day” means a calendar day, provided, that, if an obligation under this Agreement falls due on a Saturday, Sunday or legal holiday, the obligation shall be due the next business day worked.

“Dollars” and “\$” mean United States of America dollars.

“Estimated Cost of Work” shall have the meaning set forth in Section 6.1 of this Agreement.

“Good Utility Practice” means any of the practices, methods, and acts engaged in or approved by a significant portion of the electric utility industry during the relevant time period, or any of the practices, methods, and acts which, in the exercise of reasonable judgment in light of the facts known at the time the decision was made, could have been expected to accomplish the desired result at a reasonable cost consistent with good business practices, reliability, safety, and expedition. Good Utility Practice is not intended to be limited to the optimum practice, method, or act, to the exclusion of all others, but rather to refer to acceptable practices, methods, or acts generally accepted in the region in which the Project is located. Good Utility Practice shall include, but not be limited to, NERC (defined below) criteria, rules, guidelines, and standards, NPCC (defined below) criteria, rules, guidelines, and standards, NYSRC (defined below) criteria, rules, guidelines, and standards, and NYISO (defined below) criteria, rules, guidelines, and standards, where applicable, and as they may be amended from time to time, including the rules, guidelines, and criteria of any successor organization to the foregoing entities. When applied to Customer, the term Good Utility Practice shall include standards applicable to a utility generator connecting to the distribution or transmission facilities or system of another utility.

“NPCC” shall mean the Northeast Power Coordinating Council (a reliability council under Section 202 of the Federal Power Act) or any successor organization.

“NERC” shall mean the North American Electric Reliability Corporation or any successor organization.

“NYISO” shall mean the New York Independent System Operator, Inc.

“NYSRC” shall mean the New York State Reliability Council.

“Project Manager” means the respective representative of Customer and the Company appointed pursuant to Section 26.1 of this Agreement.

“Project” means the Work to be performed under this Agreement by the Company.

“Subcontractor” means any organization, firm or individual, regardless of tier, which Company retains in connection with the Agreement.

“Supplemental Conditions” means those terms and conditions, if included in the Agreement by mutual written agreement of the Parties, which add to or modify the Agreement and are incorporated by reference as if fully set forth in the Agreement. In the case of a conflict between the Supplemental Conditions and the Agreement, the Supplemental Conditions shall prevail.

“Work” shall have the meaning specified in Section 3.1 of this Agreement.

2.0 Term

2.1 This Agreement shall become effective as of the Effective Date and shall remain in full force and effect until all amounts due and owing hereunder from Customer to Company have been paid in full as contemplated by this Agreement, or until terminated in accordance with the terms of this Agreement, whichever occurs first. From and after the date of receipt of final payment and written acknowledgement by Company that full payment for the Work has been paid by Customer, this Agreement shall terminate and be of no further force or effect and the Parties shall have no obligation to each other hereunder, provided, however, that such termination shall not affect or excuse the performance of either Party under any provision of this Agreement that by its terms survives any such termination.

3.0 Scope of Work

3.1 The scope of work is set forth in Schedule A of this Agreement, attached hereto and incorporated herein by reference (the “Work”).

- 3.2 Company shall use reasonable efforts to perform the Work in accordance with Good Utility Practice. Prior to completion of the Work, Customer shall have the right to notify the Company in writing of the need for correction of defective Work that does not meet the standards of this Section 3.2 and the Company shall promptly complete, correct, repair or replace such defective Work, as appropriate, at no added cost to the Customer if the previously incurred total Company Reimbursable Costs are equal to or in excess of the Estimated Cost of Work. However, as long as the total Company Reimbursable Costs do not exceed the Estimated Cost of Work, then items of defective Work identified by the Customer prior to completion of the Work that Company reasonably determines need to be re-performed in order to comply with the standards in this Section 3.2 shall be completed or re-performed subject to reimbursement of all costs associated therewith as part of Company Reimbursable Costs. The remedy set forth in this Section shall be the sole and exclusive remedy available to Customer for any failure of Company to meet the performance standards or requirements set forth in this Agreement.

4.0 Changes in the Work

- 4.1 If Customer requests a change in the Work, such request shall be submitted to the Company in writing. If the Parties agree to a change in the Work, such agreed change will be set forth in writing, and the Work schedule shall be adjusted and/or extended as mutually agreed by the Parties. Any additional costs arising from such change shall be paid by the Customer as part of Company Reimbursable Costs when invoiced by the Company in accordance with Section 7.3 of this Agreement.
- 4.2 Notwithstanding the above, and subject to compliance with the last sentence of this Section, Company, without Customer's consent, may make any reasonable changes in the Work in order to ensure the completion of the Project, prevent delays in the schedule, meet the requirements of governmental authorities, laws, regulations, ordinances, Good Utility Practice and/or codes or to enable Company's utility facilities to continue, commence or recommence commercial operations in accordance with all applicable legal and regulatory requirements and all applicable industry codes and standards ("Company Changes"). The Work schedule shall be adjusted accordingly and any additional costs shall be paid by the Customer as part of Company Reimbursable Costs when invoiced by the Company in accordance with Section 7.3 of this Agreement. If Company becomes aware of the need to make a Company Change that is reasonably expected to have a significant impact on cost or schedule, Company shall provide Customer with written notice of such contemplated Company Change, each such notice to be provided in advance, if possible, but, in any event, as soon as may be reasonably practicable under the circumstances.

5.0 **Performance and Schedule**

- 5.1 The Company shall use commercially-reasonable efforts to attempt to have Work performed by its direct employees performed during normal working hours. The foregoing notwithstanding, if Work is performed outside of normal working hours, Customer shall be responsible for paying all actual costs incurred in connection therewith, including, without limitation, applicable overtime costs, as part of Company Reimbursable Costs.
- 5.2 If Customer requests, and the Company agrees, to work outside normal working hours due to delays in the Project schedule or for other reasons, Company shall be entitled to recover all actual costs resulting therefrom as part of Company Reimbursable Costs.
- 5.3 The Projected Milestone Schedule is set forth in Schedule B, attached hereto and incorporated herein by reference. The Projected Milestone Schedule is a projection only and subject to change. Neither Party shall be liable for failure to meet the Projected Milestone Schedule, any milestone, or any other projected or preliminary schedule in connection with this Agreement, the Work or the Project.

6.0 **Estimate Only; Customer Obligation to Pay Company Reimbursable Costs.**

- 6.1 The current good faith estimate of the total Company Reimbursable Costs, exclusive of applicable taxes, to complete the Work is Four Million One Hundred and Thirteen Thousand Dollars (\$4,113,000) ("*Estimated Cost of Work*"). The Estimated Cost of Work, including any revisions thereto, is an estimate only. The Estimated Cost of Work (and any revisions thereto) and any other estimates provided under or in connection with this Agreement or the Work shall not limit Customer's obligation to pay Company for all Company Reimbursable Costs actually incurred by Company and/or its affiliates.

7.0 **Payment**

- 7.1 Customer shall pay or reimburse Company for all Company Reimbursable Costs incurred in connection with performance of the Work described in PART 1 of Schedule A hereto ("*Preliminary Engineering & Design Work*"). Within thirty (30) Days following the Effective Date, the Company shall invoice Customer for an initial prepayment of Five Hundred Ninety Thousand Dollars (\$590,000) ("*Initial Prepayment*") and Customer shall pay the Initial Prepayment to Company within thirty (30) Days of invoice receipt. Company shall not be obligated to commence Work under this Agreement prior to receiving the Initial Prepayment.
- 7.2 Once Company has completed the Preliminary Engineering & Design Work and Customer has delivered a written consent to proceed ("*Consent to Proceed*"), the Company shall commence the Work described in PART 2 of Schedule A hereto

(the "Implementation Work"). Customer shall pay or reimburse Company for all Company Reimbursable Costs actually incurred in connection with performance of the Implementation Work. Monies remaining from the Initial Prepayment after payment of all Company Reimbursable Costs for the Preliminary Engineering & Design Work, if any, shall be credited to the Customer for use toward defraying Company Reimbursable Costs for the Implementation Work.

- 7.3 Company may periodically invoice Customer for Company Reimbursable Costs incurred. Company is not required to issue periodic invoices to Customer and may elect, in its sole discretion, to continue performance hereunder after the depletion of the Initial Prepayment or any subsequent prepayment made by Customer, and invoice Customer at a later date. Except as otherwise expressly provided for in this Agreement, all invoices shall be due and payable within thirty (30) Days following receipt of the invoice. The payment of interest by Customer on overdue amounts in connection with this Agreement shall be governed by subparagraphs 5 through 8 of paragraph D as set forth in the Customer's prompt payment policy attached hereto as Schedule E ("Prompt Payment Policy Interest Provisions"). For the avoidance of doubt: in the event of any difference or conflict between the terms of this Agreement and the terms of the Prompt Payment Policy Interest Provisions, the Prompt Payment Policy Interest Provisions shall govern. In addition to any other rights and remedies available to Company, if any payment due from Customer under this Agreement is not received within thirty (30) Days following the applicable due date, Company may suspend any or all Work pending receipt of all overdue amounts from Customer.

If Customer claims exemption from sales tax, Customer agrees to provide Company with an appropriate, current and valid tax exemption certificate, in form and substance satisfactory to Company, relieving Company from any obligation to collect sales taxes from Customer ("Sales Tax Exemption Certificate"). During the term of this Agreement, Customer shall promptly provide Company with any modifications, revisions or updates to the Sales Tax Exemption Certificate or to Customer's exemption status. If Customer fails to provide an acceptable Sales Tax Exemption Certificate for a particular transaction, Company shall add the sales tax to the applicable invoice to be paid by Customer.

- 7.4 Company's invoices to Customer for all sums owed under this Agreement shall be sent to the individual and address specified below, or to such other individual and address as Customer may designate upon written notice to the Company:

New York Power Authority
ATTN: Manna Yu, Accounts Payable
P. O. Box 437
White Plains, N.Y. 10602-0437

- 7.5 Payments to the Company shall be made by Automated Clearing House transfer in accordance with the following bank instructions (please include a copy of the invoice):

Wire Payment: JP Morgan Chase
ABA#.021000021
Credit: National Grid USA
Account #777149642

8.0 **Final Payment, Books & Recordkeeping**

- 8.1 Following completion of the Work, the Company shall perform an overall reconciliation of the total of all Company Reimbursable Costs to the invoiced costs previously paid to Company by Customer under this Agreement (“*Total Payments Made*”). If the total of all Company Reimbursable Costs is greater than the Total Payments Made, the Company shall provide a final invoice to Customer for the balance due to the Company under this Agreement (the “*Balance Amount*”). If the Total Payments Made is greater than the total of all Company Reimbursable Costs, Company shall reimburse the difference to Customer (“*Reimbursement Amount*”). The Reimbursement Amount or Balance Amount, as applicable, shall be due and payable upon final reconciliation but no later than sixty (60) Days after such reconciliation.
- 8.2 The Company shall keep accurate books and records of accounts to reasonably document the Company Reimbursable Costs incurred in connection with performance of the Project and Work or otherwise incurred in connection with this Agreement (such books and records kept in accordance with generally accepted accounting principles). All such books and records to the extent relating to amounts charged to Customer in connection with this Agreement shall be available for review (at Customer’s sole cost) by authorized representatives of Customer upon reasonable advanced written request (of not less than ten (10) days), any such review to be conducted at Company’s facilities during customary business hours. If any such review determines that there has been an amount under or overpaid in accordance with the terms of this Agreement, then the Party owing such amount shall promptly pay the amount due to the other Party. The obligations under this Article shall expire one (1) year after the termination or cancellation of this Agreement.

9.0 **Customer’s Responsibilities-**

- 9.1 The Customer shall perform the obligations set forth in Schedule C of this Agreement, attached hereto and incorporated herein by reference.
- 9.2 Customer shall reasonably cooperate with Company as required to facilitate Company’s performance of the Work.

9.3 Company shall have no responsibility or liability under this Agreement for any delay in performance, defective performance or nonperformance to the extent such delay in performance, defective performance or nonperformance is caused by the inability or failure of (a) Customer to cooperate or to perform any tasks or responsibilities contemplated to be performed or undertaken by the Customer under this Agreement or (b) Customer and Company to reach agreement on any matter requiring their mutual agreement under the terms of this Agreement.

10.0 **Meetings**

10.1 Each Party's Project Manager shall attend Project meetings at times and places mutually agreed to by the Parties.

11.0 **Disclaimers**

11.1 THE COMPANY IS NOT IN THE BUSINESS OF PERFORMING DESIGN, ENGINEERING OR CONSTRUCTION SERVICES FOR PROFIT AND IS NOT RECEIVING ANY FEE OR PROFIT (AS CONTRASTED WITH COST REIMBURSEMENT) FOR ITS PERFORMANCE OF THE WORK HEREUNDER. THE EXCLUSIVE REMEDY GRANTED TO CUSTOMER FOR ANY ALLEGED FAILURE OF COMPANY TO MEET THE PERFORMANCE STANDARDS OR REQUIREMENTS SET FORTH IN SECTION 3.2 OF THIS AGREEMENT. COMPANY MAKES NO WARRANTIES, REPRESENTATIONS, OR GUARANTEES IN CONNECTION WITH THE AGREEMENT, ANY PROJECTOR ANY WORK PERFORMED IN CONNECTION THEREWITH, WHETHER WRITTEN, ORAL OR STATUTORY, EXPRESS OR IMPLIED, INCLUDING, WITHOUT LIMITATION, THE IMPLIED WARRANTIES OF MERCHANTABILITY AND FITNESS FOR A PARTICULAR PURPOSE, ALL OF WHICH ARE HEREBY EXPRESSLY DISCLAIMED. CUSTOMER ACKNOWLEDGES AND AGREES THAT ANY WARRANTIES PROVIDED BY ORIGINAL MANUFACTURERS, LICENSORS, OR PROVIDERS OF MATERIAL, EQUIPMENT, SERVICES OR OTHER ITEMS PROVIDED OR USED IN CONNECTION WITH THE WORK, INCLUDING ITEMS INCORPORATED IN THE WORK ("THIRD PARTY WARRANTIES"), ARE NOT TO BE CONSIDERED WARRANTIES OF THE COMPANY AND THE COMPANY MAKES NO REPRESENTATIONS, GUARANTEES, OR WARRANTIES AS TO THE APPLICABILITY OR ENFORCEABILITY OF ANY SUCH THIRD PARTY WARRANTIES.

11.2 Notwithstanding any other provision of this Agreement, this Article shall survive the termination, cancellation or expiration of this Agreement.

12.0 **Liability and Indemnification**

12.1 To the fullest extent allowed by law, Customer shall indemnify and hold harmless, and at Company's option, defend Company, its parents and affiliates and their respective contractors, officers, directors, servants, agents, representatives, and employees (each, individually, an "*Indemnified Party*" and, collectively, the "*Indemnified Parties*"), from and against any and all direct liabilities, damages, losses, costs, expenses (including, without limitation, any and all reasonable attorneys' fees and disbursements), causes of action, suits, liens, claims, penalties, obligations, demands or judgments of any nature, including, without limitation, for death, personal injury and property damage, and claims brought by third parties for personal injury and/or property damage (collectively, "*Damages*"), incurred by any Indemnified Party to the extent caused by the negligence, unlawful act or omission, or intentional misconduct of Customer, its parents or affiliates, third-party contractors, or their respective officers, directors, servants, agents, representatives, and employees, arising out of or in connection with this Agreement, the Project, or Work, except to the extent such Damages are caused by the negligence, intentional misconduct or unlawful act of the Company, the Company's contractors or any person or entity for whom Company is legally responsible.

Customer shall also indemnify and hold harmless the Company and its affiliates from and against the cost consequences of any tax liability imposed against or on Company and/or its affiliates as the result of payments made in connection with this Agreement, as well as any related interest and penalties, other than interest and penalties attributable to any delay directly caused by Company or the applicable Company affiliate.

12.2 The Company's total cumulative liability to Customer for all claims of any kind, whether based upon contract, tort (including negligence and strict liability), or otherwise, for any loss, injury, or damage connected with, or resulting from, this Agreement, the Project or the Work, shall not exceed the aggregate amount of all payments made to Company by Customer as Company Reimbursable Costs under this Agreement.

Anything in this Agreement to the contrary notwithstanding, if any Party's liability in connection with this Agreement is limited or capped pursuant to any applicable law, statute, rule or regulation, then the other Party hereto shall be entitled to elect an identical liability limitation and/or cap as if such law, statute, rule or regulation were applicable to such Party.

- 12.3 Neither Party shall be liable to the other Party for consequential, indirect, special, incidental, multiple, or punitive damages (including, without limitation, attorney's fees or litigation costs) in connection with or related to this Agreement, including, without limitation, damage claims based on causes of action for breach of contract, tort (including negligence), or any other theory of recovery, whether or not (i) such damages were reasonably foreseeable or (ii) the Parties were advised or aware that such damages might be incurred.
- 12.4 Neither Party shall be liable to the other Party for claims of, or damages for, lost profits, delays, loss of use, business interruption, or claims of customers, whether such claims are categorized as direct or consequential damages, or whatever the theory of recovery, and whether or not (i) such damages were reasonably foreseeable or (ii) the Parties were advised or aware that such damages might be incurred.
- 12.5 Anything in this Agreement to the contrary notwithstanding, neither Party shall be responsible for any failure or inability to perform hereunder to the extent such failure or inability is caused by the acts or omissions of the other Party (including any contractor of such other Party or any person or entity for whom such other Party is legally responsible) or any third party.
- 12.6 Notwithstanding any other provision of this Agreement, this Article shall survive the termination, cancellation or expiration of this Agreement.

13.0 **Employee Claims; Insurance**

- 13.1 The Company and Customer elect to self-insure and to maintain the insurance coverage amounts set forth in Schedule D of this Agreement.
- 13.2 Each Party shall be separately responsible for insuring its own property and operations.

14.0 **Assignment and Subcontracting**

- 14.1 Each Party may assign this Agreement or any part thereof to any affiliated entity controlling, controlled by, or under common control with, the assigning Party provided such assignee shall be bound by the terms and conditions of this Agreement. For purposes of this Section, "control" of an entity shall mean the ownership of, with right to vote, fifty percent (50%) or more of the outstanding voting securities or equity of such entity. Any assignment of this Agreement in violation of the foregoing shall be voidable at the option of the non-assigning Party.

15.0 **Independent Contractor; No Utility Services**

15.1 Company and Customer shall be independent contractors, and neither Party shall be deemed to be an agent of the other Party. This Agreement is not an agreement to provide or take utility services of any kind, including, without limitation, interconnection or other electric transmission services.

16.0 **Examination, Inspection and Witnessing**

16.1 Subject to Customer's and its representatives' compliance with Company's security and other access requirements, the Customer and/or its representatives shall have the right to inspect and examine the Work, from time to time, at Customer's sole cost and expense, with reasonable prior notice to Company. Unless otherwise agreed between the Parties, such inspections, examinations and tests shall be scheduled during normal business hours.

16.2 Company shall inspect all Work and make or cause to be made all tests required by Good Utility Practice at Customer's sole cost and expense as part of Company Reimbursable Costs.

16.3 At times and places mutually agreed to by the Parties, Customer and Company, or their respective designated representatives, shall be entitled to witness any test contemplated by this Agreement.

17.0 **Safety**

17.1 Each Party shall be solely responsible for the safety and supervision of its own employees, representatives and contractors involved with the Work or on the Site(s). In connection with the Project, each Party shall, and shall require its representatives, contractors, and employees to, comply with all applicable Federal, state and local health and safety requirements, rules, regulations, laws and ordinances, including without limitation, the safety regulations adopted under the Occupational Safety and Health Act of 1970 (OSHA), as amended from time to time. While on the property (including, without limitation, easements or rights of way) of, or accessing the facilities of, the other Party, each Party's employees and/or contractors and representatives shall at all times abide by such other Party's safety standards and policies, switching and tagging rules, and escort and other applicable access requirements. The Party owning or controlling the property or facilities shall have the authority to suspend the other Party's access, work or operations in and around such property or facilities if, in its sole judgment, at any time hazardous conditions arise or any unsafe practices are being followed by the other Party's employees, agents, representatives or contractors.

18.0 **Approvals, Permits and Easements**

18.1 The actual cost of seeking and/or obtaining all permits, licenses, permissions, consents and Required Regulatory Approvals sought and/or obtained by or on behalf of Company for the Project and the Work shall be paid for by Customer as part of Company Reimbursable Costs. If Company anticipates that the cost of obtaining any such permit, license, permission, consent or Required Regulatory Approval will represent a substantial portion of Project costs, Company shall provide written notice thereof to Customer, such notice to be provided promptly following Company's determination that such costs will be incurred.

19.0 **Suspension of Work**

19.1 Subject to Section 19.2, below, Customer may interrupt, suspend, or delay the Project upon written notice to the Company specifying the nature and expected duration of the interruption, suspension, or delay. Company will use commercially reasonable efforts to suspend performance of the Work when so requested by Customer. Customer shall be responsible to pay Company (as part of Company Reimbursable Costs) for all costs incurred by Company that arise as a result of such interruption, suspension or delay.

19.2 As a precondition to the Company resuming the Work following a suspension under Section 19.1, the Projected Milestone Schedule and the Estimated Cost of Work shall be revised as mutually agreed by the Parties to reflect the interruption, suspension, or delay. Adjustments to the Company Reimbursable Costs shall include any costs or expenses the Company incurs as a result of the interruption, suspension, or delay.

20.0 **Right to Terminate Agreement**

20.1 Notwithstanding any other provision of this Agreement, if either Party (the "Breaching Party") (a) fails to pay any amount when due under the terms of this Agreement, or (b) fails to comply with or perform, in any material respect, any other terms or conditions of this Agreement; then the other Party (the "Non-Breaching Party") shall have the right, without prejudice to any other right or remedy and after giving five (5) Days' written prior notice to the other Party and a reasonable opportunity for cure (not to exceed thirty (30) Days in the case of a failure to pay amounts when due), to terminate this Agreement, in whole or in part, and thereupon each Party shall promptly discontinue its performance hereunder to the extent feasible and make every reasonable effort to procure cancellation of existing Work- and/or Project- related commitments, orders and contracts upon terms that are reasonably expected to minimize all associated costs. However, nothing herein will restrict Company's ability to complete aspects of the Work that Company must reasonably complete in order return its facilities and the Sites to a configuration in compliance with Good Utility Practice and all applicable laws, codes, regulations and standards. Subject to compliance

with Section 26.3 of this Agreement, if applicable, the Non-Breaching Party shall also have the right to pursue any and all rights it may have against the Breaching Party under applicable law, subject to other applicable terms and conditions of this Agreement (including, without limitation, any limitations on liability contained herein).

20.2 If the event of termination or cancellation of the Work in connection in this Agreement, Customer shall pay Company for:

- a. all Company Reimbursable Costs for Work performed on or before the effective date of termination or cancellation;
- b. all other Company Reimbursable Costs reasonably incurred by Company in connection with the Work prior to the effective date of termination or cancellation, including, without limitation, for materials, equipment, tools, construction equipment and machinery, engineering and other items, materials, assets or services which cannot reasonably be avoided, mitigated or cancelled;
- c. all Company Reimbursable Costs reasonably incurred to unwind Work that was performed prior to the effective date of termination or cancellation to the extent reasonably necessary to return Company's facilities and the Site(s) to a configuration in compliance with Good Utility Practice and all applicable laws, codes, regulations and standards, including, without limitation, applicable NERC and NPCC protection requirements; and
- d. all Company Reimbursable Costs arising from cancellation costs relating to orders or contracts entered into in connection with the Work prior to the effective date of termination or cancellation; and
- e. all Company Reimbursable Costs arising from other reasonable demobilization expenses incurred by Company which cannot be reasonably avoided or mitigated.

21.0 Delays; Unforeseen Difficulties

21.1 Any delays or failure of performance by Company shall not constitute a default and shall be excused hereunder, if and to the extent such delays or failures of performance are caused by unforeseen conditions or occurrences beyond the reasonable control of the Company (including, without limitation, conditions of or at the Site(s), delays in shipments of materials and equipment and the unavailability of materials.) If Company becomes aware of circumstances that make it reasonably likely that such a delay or failure will occur and will have a significant impact on cost or schedule, Company shall provide Customer with written notice thereof, each such notice to (i) include the estimated impact of such delay or failure and (ii) be provided in advance, if possible, but, in any event, as soon as may be reasonably practicable under the circumstances.

22.0 Force Majeure

22.1 A "*Force Majeure Event*" shall include fire, flood, windstorm, adverse weather conditions, emergencies, explosion, terrorism, riot, war, sabotage, acts of God, strikes or labor slow-downs, court injunction or order, federal and/or state law or regulation, delays by governmental authorities in approving regulatory, license and permit requests necessary in connection with the Work or Project, or order by any federal or state regulatory agency, or other similar causes beyond the affected Party's reasonable control. Without limiting the foregoing, a "Force Majeure Event" shall also include unavailability of personnel, equipment, supplies, or other resources ("*Resources*") due to diversion of such Resources for other utility-related duties in connection with an emergency or other similar contingency, including, without limitation, storms or other adverse weather condition. If a Force Majeure Event should occur and impair the ability of either or both Parties to perform its, or their respective, obligations hereunder, then, to the extent affected by such Force Majeure Event, the performance of this Agreement, with the exception of payment obligations, shall be suspended for the duration of such Force Majeure Event. At the conclusion of a Force Majeure Event, the price and time for performance under this Agreement shall be adjusted as reasonably necessary to overcome the effect of the delay occasioned by such Force Majeure Event. The foregoing notwithstanding and with the exception of payment obligations, if, as the direct or indirect result of any Force Majeure Event, the Parties' continued performance hereunder becomes irreparably impaired or prevented, the Parties may mutually agree to terminate this Agreement, in whole or in part, with no further obligation or liability; provided, however, that, notwithstanding any such termination, Customer shall pay the Company all of the Company Reimbursable Costs as contemplated by Section 20.2 of this Agreement. For the avoidance of doubt: to the extent any Party has a payment obligation pursuant to the terms of this Agreement, such payment obligation shall not be subject to or conditioned upon such Party receiving funding or reimbursement from any third party (and any failure to secure such funding or reimbursement shall not constitute a Force Majeure Event), nor shall any such

obligation be conditioned upon the other Party executing any certificates or other instruments not expressly and specifically required by the terms of this Agreement.

22.2 Within thirty (30) Days after the termination of any delay occasioned by a Force Majeure Event, the affected Party shall give written notice to the other Party specifying the estimated impacts regarding price and time for performance as a result of the delay.

23.0 **[Reserved]**

24.0 **Proprietary and Confidential Information**

24.1 The rights and obligations of the Parties with respect to confidential and proprietary information (including, without limitation, critical energy infrastructure information and critical infrastructure protection information) shall be governed by the Confidentiality Agreement made as of July 31, 2014 by and among Consolidated Edison Company of New York, Inc., Orange & Rockland Utilities, Inc., the Company, New York State Electric & Gas Corporation, Rochester Gas and Electric Corporation, the Customer, Long Island Power Authority, Long Island Lighting Company, and Central Hudson Gas & Electric Corporation (the "Confidentiality Agreement").

25.0 **Governing Law**

25.1 This Agreement is made and shall be interpreted, construed, governed, and enforced in accordance with the laws of the State of New York without reference to such State's conflict-of-laws doctrine.

25.2 The Company and Customer agree to submit to the personal jurisdiction of the courts in the State of New York, or the Federal District courts in the State of New York, as permitted by law, with respect to any matter or dispute arising out of this Agreement.

26.0 Miscellaneous

- 26.1 **Project Managers.** Promptly following the Effective Date, each Party shall designate a Project Manager and shall provide the other Party with a written notice containing the name and contact information of its Project Manager. Whenever either Party is entitled to approve a matter, the Project Manager for the Party responsible for the matter shall notify the Project Manager of the other Party of the nature of such matter. The Project Managers shall discuss such matter, and each Project Manager shall confer on such matter on behalf of his/her Party. The foregoing notwithstanding, in no event shall Project Managers be authorized to amend or modify the provisions of this Agreement. Each Party may change its Project Manager, from time to time, by providing written notice thereof to the other Party.
- 26.2 **Company Intellectual Property.** Notwithstanding any provision of this Agreement to the contrary, all assets, equipment and facilities procured or constructed by or on behalf of Company, and all plans, designs, specifications, drawings and other materials and documents created or prepared by or for Company, in connection with the Work, and all title, copyright, intellectual property and other rights therein, shall be and remain the sole property of Company.
- 26.3 **Dispute Resolution.** Any dispute arising under this Agreement shall be the subject of good-faith negotiations between the Parties. Each Party shall designate one or more representatives with the authority to negotiate the matter in dispute for the purpose of participating in such negotiations. Unless a Party identifies exigent circumstances reasonably requiring expedited resolution of the dispute by a court or agency with jurisdiction over the dispute, any dispute that is not resolved through good-faith negotiations after a negotiation period of not less than sixty (60) days may be submitted by either Party for resolution to a court or to an agency with jurisdiction over the dispute. Notwithstanding the foregoing, any dispute arising under this Agreement may be submitted to non-binding arbitration or any other form of alternative dispute resolution upon the agreement of both Parties to participate in such an alternative dispute resolution process.

- 26.4 **Compliance with Law, Standard Safety Practices, etc.** Each Party shall comply, at all times, with, and procure the compliance, at all times, by all of its subcontractors with, all applicable federal, state, and local laws, rules, codes, regulations, and ordinances in connection with this Agreement and performance of the Work hereunder. Such compliance shall include, among other things, compliance with all applicable wage and hour laws and regulations and all other laws and regulations dealing with or relating to the employment of persons, and the payment of contributions, premiums, and taxes required by such laws and regulations. For the avoidance of doubt: neither Party shall be required to undertake or complete any action or performance under this Agreement that is inconsistent with such Party's standard safety practices, its material and equipment specifications, its design criteria and construction procedures, its labor agreements, Good Utility Practice and/or any applicable laws or regulations.
- 26.5 **Form and Address.** All notices, invoices and other communications from either Party to the other hereunder shall be in writing and shall be deemed received (i) upon actual receipt when personally delivered, (ii) upon acknowledgment of receipt if sent by facsimile, (iii) upon the expiration of the third (3rd) business Day after being deposited in the United States mails, postage prepaid, certified or registered mail, or (iv) upon the expiration of one (1) business Day after being deposited during the regular business hours for next-day delivery and prepaid for overnight delivery with a national overnight courier, addressed to the other Party. Each Party may change its address by giving the other Party notice thereof in conformity with this Section. Any payments made under this Agreement, if made by mail, shall be deemed to have been made on the date of receipt thereof.
- 26.6 **Exercise of Right.** No failure or delay on the part of either Party in exercising any right, power, or privilege hereunder, and no course of dealing between the Parties, shall operate as a waiver thereof; nor shall any single or partial exercise of any right, power, or privilege hereunder preclude any other or further exercise thereof or the exercise of any other right, power, or privilege.
- 26.7 **Additional Actions and Documents.** Each Party hereby agrees to take or cause to be taken such further actions, to execute, acknowledge, deliver and file, or cause to be executed, acknowledged, delivered and filed, such further documents and instruments, and to use its commercially reasonable efforts to obtain such consents, as may be necessary or as may be reasonably requested in order to fully effectuate the purposes, terms, and conditions of this Agreement, whether at or after the execution of this Agreement.
- 26.8 **Headings.** The descriptive headings of the several Articles, sections, and paragraphs of this Agreement are inserted for convenience only and do not constitute a part of this Agreement. Such headings shall not in any way define or affect the meaning, construction, or scope of any of the provisions hereof.

- 26.9 **Incorporation of Schedules and Exhibits.** The schedules, attachments and exhibits referenced in and attached to this Agreement shall be deemed an integral part hereof to the same extent as if written in whole herein. In the event that any inconsistency exists between the provisions of this Agreement and any schedules, attachments or exhibits attached hereto, the provisions of this Agreement shall supersede the provisions of any such schedules, attachments or exhibits.
- 26.10 **Counterparts.** This Agreement may be executed in multiple counterparts, each of which shall be considered an original. The exchange of copies of this Agreement and of signature pages by facsimile or other electronic transmission (including, without limitation, by e-mailed PDF) shall constitute effective execution and delivery of this Agreement as to the Parties and may be used in lieu of the original Agreement for all purposes. Signatures of the Parties transmitted by facsimile or other electronic means (including, without limitation, by e-mailed PDF) shall be deemed to be their original signatures for all purposes.
- 26.11 **Prior Agreements; Modifications.** This Agreement and the schedules, attachments, and exhibits attached hereto, together with the Confidentiality Agreement, constitute the entire agreement between the Parties with respect to the subject matter hereof, and supersede all previous understandings, commitments, or representations concerning such subject matter. Each Party acknowledges that the other Party has not made any representations other than those that are contained herein. This Agreement may not be amended or modified in any way, and none of its provisions may be waived, except by a writing signed by an authorized representative of the Party against whom the amendment, modification, or waiver is sought to be enforced.
- 26.12 **Severability.** Nothing contained in this Agreement shall be construed so as to require the commission of any act contrary to law, and wherever there is any conflict between any provision of this Agreement and any law, such law shall prevail; provided, however, that in such event, the provisions of this Agreement so affected shall be curtailed and limited only to the extent necessary to permit compliance with the minimum legal requirement, and no other provisions of this Agreement shall be affected thereby and all such other provisions shall continue in full force and effect.
- 26.13 **Nouns and Pronouns.** Whenever the context may require, any pronouns used in this Agreement shall include the corresponding masculine, feminine, or neuter forms, and the singular forms of nouns and pronouns shall include the plural, and vice versa.
- 26.14 **No Third Party Beneficiaries.** Nothing in this Agreement is intended to confer on any person, other than the Parties, any rights or remedies under or by reason of this Agreement.

- 26.15 **Validity; Required Regulatory Approvals.** Each Party hereby represents that the provisions of this Agreement constitute valid and legally binding obligations of such Party and are enforceable in accordance with their terms.

The obligations of each Party under this Agreement are expressly contingent upon (i) each Party receiving all approvals, authorizations, consents, franchises, Permits, and licenses from any local, state, or federal regulatory agency or other governmental agency that may be required for such Party in connection with the performance of such Party's obligations under or in connection with this Agreement (the "*Required Regulatory Approvals*"), (ii) each Required Regulatory Approval being granted without the imposition of any modification or condition of the terms of this Agreement or the subject transactions, unless such modification(s) or condition(s) are agreed to by both Parties in their respective sole discretion, and (iii) all applicable appeal periods with respect to the Required Regulatory Approvals having expired without any appeal having been made or, if such an appeal has been made, a full, final and non-appealable determination having been made regarding same by a court or other administrative body of competent jurisdiction, which determination disposes of or otherwise resolves such appeal (or appeals) to the satisfaction of both Parties in their respective sole discretion. If any application or request is made in connection with seeking any Required Regulatory Approval and is denied, or is granted in a form, or subject to conditions, that either Party rejects, in its sole discretion, as unacceptable, this Agreement shall terminate as of the date that a Party notifies the other Party of such denial or rejection, in which event the obligations of the Parties under this Agreement shall cease as of such date and this Agreement shall terminate, subject to Customer's obligation to pay Company in accordance with the terms of this Agreement (including, without limitation, Section 20.2 hereof) for all Company Reimbursable Costs incurred. All of the Company's actual costs in connection with seeking Required Regulatory Approvals shall be included within the meaning of the term Company Reimbursable Costs and shall be paid for by Customer.

- 26.16 **Notices** All formal notices, demands, or communications under this Agreement shall be submitted in writing either by hand, registered or certified mail, or recognized overnight mail carrier to:

To Customer:

Mr. Andrew Sumner
Acting VP – Project Management
New York Power Authority
123 Main Street
White Plains, NY 10601
(914) 681-6706

To Company:

Mr. William Malee
Director, Transmission Commercial Services
National Grid
40 Sylvan Road
Waltham, MA 02451
(781) 907-2422

[Signatures are on following page.]

IN WITNESS WHEREOF, each Party has executed this Agreement by its duly authorized representative as of the Effective Date.

NEW YORK POWER AUTHORITY

By: _____
Name:
Title:

NIAGARA MOHAWK POWER CORPORATION d/b/a National Grid

By: _____
Name:
Title:

Schedule A: Scope of Work

Company shall, engineer, design, procure, construct, test and commission the changes to the Company's electric delivery facilities described below.

Please Note:

This Scope of Work ("Scope") covers National Grid system upgrade facilities ("SUF") identified to date directly affected by the Marcy South Series Compensation Project.

The identified SUFs consist of multiple protective relaying upgrades, installation of addition telecommunications, and the replacement of multiple breakers at existing National Grid facilities. National Grid facilities affected include Edic, New Scotland, Clay and Volney stations.

=====

PART 1 - Preliminary Engineering & Design Work

Company shall perform the preliminary engineering and design work necessary to procure, construct, test and commission the changes to the Company's electric delivery facilities contemplated by PART 2 of this Schedule A. Upon completion of this preliminary engineering and design work, Company shall provide the Customer with a revised Estimated Cost of Work (+/- 25%) , and, following delivery of such revised Estimated Cost of Work, shall suspend Work pending Customer's delivery of its Consent to Proceed.

=====

PART 2 - Implementation Work

Company shall perform final engineering and design for, and procure, construct, test and commission, the changes to the Company's electric delivery facilities as contemplated by (i) Sections IA, IIA, IIIA, and IVA of the Revised Preliminary Engineering Report for National Grid Work to Support MSSC Project dated August 12, 2015 attached as Annex 1 to this Schedule A (the "Preliminary Engineering Report"), and (ii) the portion of the Preliminary Engineering Report entitled "DISTRIBUTION LINE INTERFERENCE MODIFICATION".

Annex 1 to Schedule A

**REVISED PRELIMINARY ENGINEERING REPORT FOR
NATIONAL GRID WORK TO SUPPORT MSSC PROJECT**

REVISED PRELIMINARY ENGINEERING REPORT
For
NATIONAL GRID WORK TO SUPPORT MSSC PROJECT

August 12, 2015

Based upon the preliminary engineering and design work that has been performed, National Grid is seeking approval to proceed with the scope of work as defined in the Cost Reimbursement Agreement, Schedule A, Part 2, per the original scope as modified per the specific changes and clarifications below. Also included is the updated estimated cost per Station. If no clarifications or changes are provided below, the work will be performed per the original scope.

Edic Station work – Original Scope

Edic-Fraser Line 24-40 will need relaying and telecommunications upgrades along with breaker replacements.

Edic Station Upgrades

Replace two (2) existing circuit breakers (R400 & R915) with ones capable of handling the anticipated Transient Recovery Voltage (“TRV”);

Replace / add six (6) line and bus Capacitance Coupled Voltage Transformers (“CCVTs”);

Replace wave trap;

New cable and raceway for separation between system ‘A’ and ‘B’ packages;

Protection

Replace existing system ‘A’ and ‘B’ line protection packages with microprocessor based series compensated line protection packages;

Control & Integration (C&I)

Reuse existing RTU / EMS points;

Upgrade controls to current standards;

Telecommunications

Replace existing system ‘A’ protection package power line carrier (“PLC”) equipment with new RFL PLC DCUB and Direct Transfer Trip (“DTT”) communications;

Replace existing system ‘B’ protection package audio tone equipment with new audio tone equipment with POTT and DTT communications;

Assumptions, Clarifications and Exceptions

New circuit breakers referred to above are assumed to be of similar physical size as the existing circuit breakers;

Existing Edic control house does not have the necessary space for additional panels, therefore, this Scope assumes that any new panels will be installed in outdoor panels or in a new Edic control house that may be constructed by National Grid;

This Scope assumes that the existing above-referenced RTU / EMS points are adequate for reuse, if outdoor cabinets utilized.

Marcy-Edic Line UE1-7 will need relaying and telecommunications upgrades.

Edic Station Upgrades

New cable and raceway for separation between system 'A' and 'B' packages;

Protection

Replace existing system 'A' pilot distance protection package with a microprocessor based line differential relay protection package.

Replace existing system 'B' line differential protection package with a microprocessor based line differential relay protection package.

Replace existing system 'A' DTT relay with a microprocessor based one for breaker failure DTT over fiber;

Control & Integration (C&I)

Reuse existing RTU / EMS points;

Telecommunications

Replace existing system 'A' protection package pilot communication equipment with fiber optic equipment;

Assumptions, Clarifications and Exceptions

Existing Edic control house does not have the necessary space for additional panels, therefore, this Scope assumes any new panels will be installed in outdoor panels or in a new Edic control house may be constructed by National Grid;

This Scope assumes that the existing above-referenced RTU / EMS points are adequate for reuse, if outdoor cabinets utilized;

This Scope also assumes that redundant fiber optic cable will be run between Marcy and Edic by others; therefore, work and cost for this are not included in the Scope.

Edic-Clay Lines 15 and 16

Protection

Replace existing 'B' protection package with a microprocessor based series compensated line protection package at each terminal.

Edic-New Scotland (14) Line

Protection

Replace existing 'B' protection package with a microprocessor based series compensated line protection package (SEL 421-5) at Edic Terminal.

Fitzpatrick-Edic (FE-1) Line

Protection

Replacement of existing 'A' and 'B' protection packages with microprocessor based series compensated line protection packages (GE D60 and SEL 421-5) at Edic Terminal.

IA. Edic Station REVISED and Updated Scope (see Reference Drawing # Drawing # D-66895-C, sht 1)

1. Due to NPCC Bulk Power separation criteria and the overcrowded conditions existing in the Edic control building, the new protective relays and telecommunications equipment for MSSC/TOTS must be installed in a new control building that will be constructed by National Grid. Evaluation of site conditions has led to a determination that the upgrades cannot be performed using outdoor panels or cabinets while still meeting Bulk Power System (BES) separation criteria.
2. The Edic-Fraser Line 24-40 protective relays and telecommunications are being designed as follows:

The A line protection package will be a directional comparison unblocking (DCUB) scheme using a GE D60 and RFL 9780 carrier equipment. Switch onto fault and stub bus protection shall be utilized.

The B line protection package will be a permissive overreaching transfer trip (POTT) scheme using an SEL-421-5 and RFL GARD8000 tone equipment. Switch onto fault protection shall be utilized.

3. The Marcy-Edic Line UE1-7 protective relays and telecommunications are being designed as follows:

The A line protection package will be a line differential SEL-411L. Redundant fiber pairs will be used for communication to Marcy. Switch onto fault and stub bus protection shall be utilized. Back up distance functions will be enabled for backup when both differential channels are lost.

The B line protection package will be a line differential SEL-311L. Redundant fiber pairs will be used for communication to Marcy. Switch onto fault and stub bus protection shall be utilized. Back up distance functions will be enabled for backup when both differential channels are lost.

A redundant direct transfer trip scheme for breaker failure at Marcy will be used. The A and B packages will use mirrored bits on fiber using SEL-351 relays. The schemes will trip the breakers and drive the reclosing relay to lockout.

The new, second fiber optic channel from Marcy (SkyWrap to be installed by Others for NYPA) will require the fiber pairs to be directed from the NYPA splice box at the Edic switchyard entry to the Edic control building, and terminated / patched by National Grid to the relay panels in order to complete the fiber path.

4. The Edic-New Scotland Line 14 protective relays and telecommunications are being designed as follows:

The A line protection package will be a permissive overreaching transfer (POTT) scheme using a GE D60 and RFL IMUX 2000 multiplexer with DS-TT cards.

The B line protection package will be a directional comparison unblocking (DCUB) scheme using an SEL-421-5 and RFL IMUX 2000 multiplexer with DS-TT cards.

5. The Edic-Clay Lines 2-15 and 1-16 protective relays have been designed and installed as follows:

The A line protection relay on each line has been replaced with an SEL-421-5 with series compensation settings capabilities. The relays have been programmed and placed in service on 5/27/15.

The existing B line protection relay on each line (ERL Phase LPro-2100) has been reprogrammed with new settings to accommodate the series compensation.

6. Certain cabling and control cabling costs were added not identified in the first version of the preliminary engineering report.

IB. Edic Station Revised and Updated Cost Estimate

Company Field Labor = \$448,000

Company Project Management and Engineering = \$186,000

Contract Labor = \$337,000

Materials = \$581,000

Transportation/Equipment = \$84,000

Other = \$16,000

Company Overheads and Costs = \$430,000

Contingency (25%) = \$520,000

TOTAL = \$2,602,000

EDIC STATION DIAGRAM

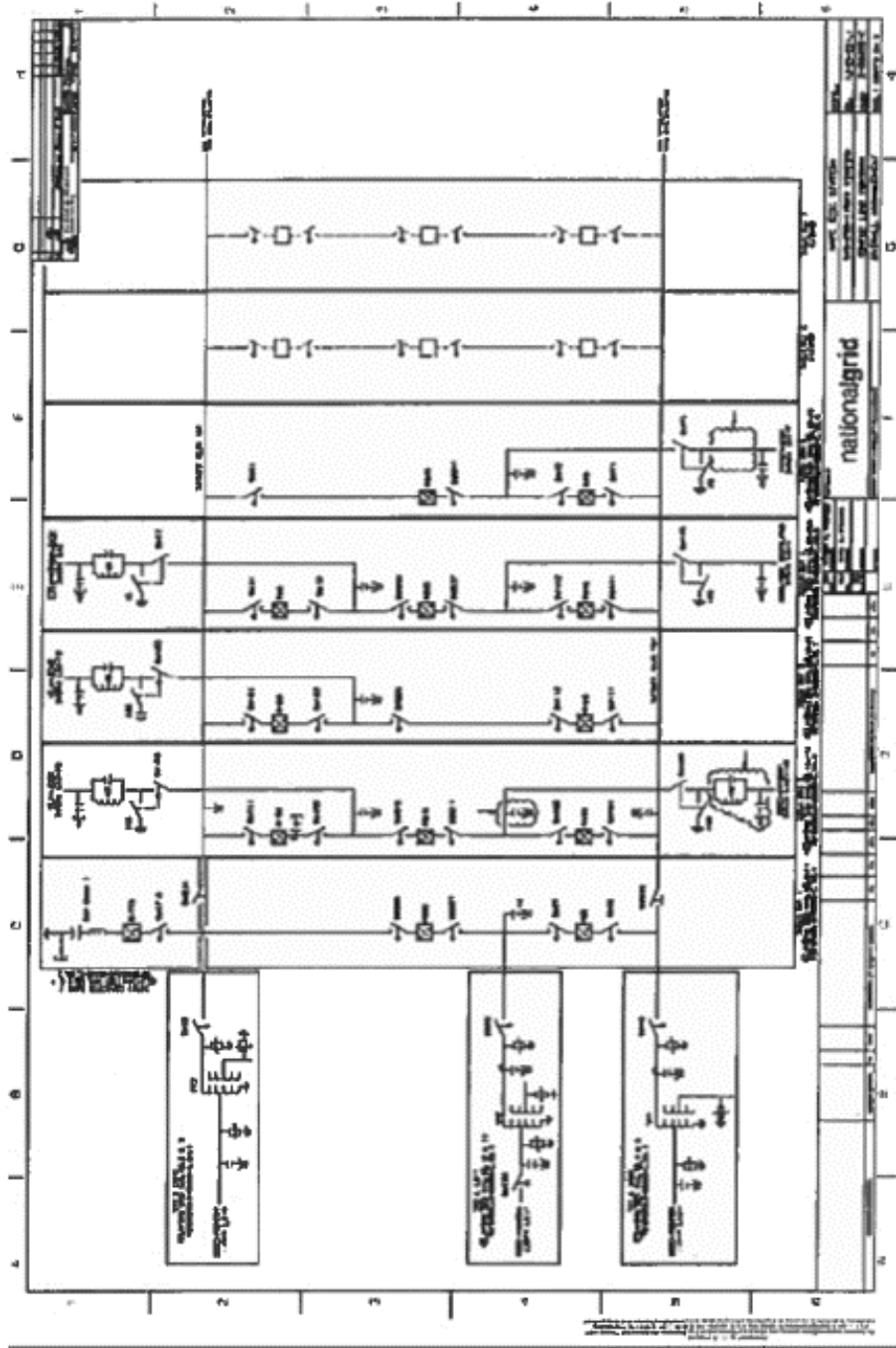

II. New Scotland Station work – Original Scope and Assumptions

Gilboa-New Scotland Line 1 will need relaying upgrades.

Protection

Replace existing system 'A' line protection package with a microprocessor based series compensated line protection package;

Control & Integration (C&I)

Reuse existing RTU / EMS points;

Assumptions, Clarifications and Exceptions

This Scope assumes that adequate system 'A' and 'B' separation exists.

Edic-New Scotland (14) Line

Protection

Replace existing 'B' protection package with a microprocessor based series compensated line protection package (SEL 421-5) at New Scotland Terminal.

Marcy-New Scotland (18) Line

Protection

Replace existing 'B' protection package with a microprocessor based series compensated line protection package (SEL 421-5) at New Scotland Terminal.

IIA. New Scotland – Updated Scope (see Reference Drawings C-8059-E shts 4, 7, 8)

1. The Original Scope assumed that New Scotland Station had proper A and B separation to meet NPCC Bulk Power criteria. During preparation of National Grid's technical scope, it was determined that control buildings 1 and 2 do not have proper separation. Only control building 3 has proper separation. In order to ensure proper separation, it was determined to install all the new relays in control building 3.
2. The Gilboa-New Scotland Line 1 protective relays and telecommunications are being designed as follows:

The A line relay protection package will be a microprocessor-based directional distance relay (GE-D60) in a permissive overreaching (POTT) scheme. An RFL GARD8000 will be used for communication to Gilboa station. The GARD8000 will be programmed to match the RFL9745 installed at Gilboa. A leased line will be used for the communication medium. This relay and telecommunications package will be installed in control building 2.

The existing B line relay protection will be renamed and re-used, with updated relay settings to accommodate the series compensation. The 21TTB/46TTB/LN1 relay will be renamed to 94TTB/LN1 and all potential and current sources will be disconnected.

3. The Edic-New Scotland Line 14 protective relays and telecommunications are being designed as follows:

To achieve proper A and B separation, the new relays for Line 14 will be installed in control building 3. This will necessitate replacement of both the A and B line protection packages.

The A line relay protection package will be a microprocessor-based directional distance relay (GE D60) in a permissive overreaching (POTT) scheme. A DS-TT card in an RFL IMUX 2000 will be used for communication to Edic station.

The B line relay protection package will be a microprocessor-based directional distance relay (SEL-421-5) configured in a permissive overreaching (POTT) scheme. A DS-TT card in an RFL IMUX 2000 will be used for communication to Edic station.

4. The Marcy-New Scotland Line 18 protective relays and telecommunications are being designed as follows:

To achieve proper A and B separation, the new relays for Line 18 will be installed in control building 3. This will necessitate replacement of both the A and B line protection packages.

The A line relay protection package will be a microprocessor-based directional distance relay (GE D60) in a directional comparison unblocking (DCUB) scheme. An RFL 9780 FSK power line carrier set will be used for communication to Marcy station.

The B line relay protection package will be a microprocessor-based directional distance relay (SEL-421-5) configured in a permissive overreaching transfer trip (POTT) scheme. An RFL GARD8000 will be used for communication to Marcy station. The GARD8000 will be programmed to match the RFL9745 installed at Marcy. A leased phone line will be used for the communication medium.

IIB. Total Estimated Cost for New Scotland Scope as revised;

Company Field Labor = \$256,000

Company Project Management and Engineering = \$133,000

Contract Labor = \$36,000

Materials = \$261,000

Transportation/Equipment = \$33,000

Other = \$8,000

Company Overheads and Costs = \$274,000

Contingency (25%) = \$249,000

TOTAL = \$1,250,000

New Scotland Diagrams

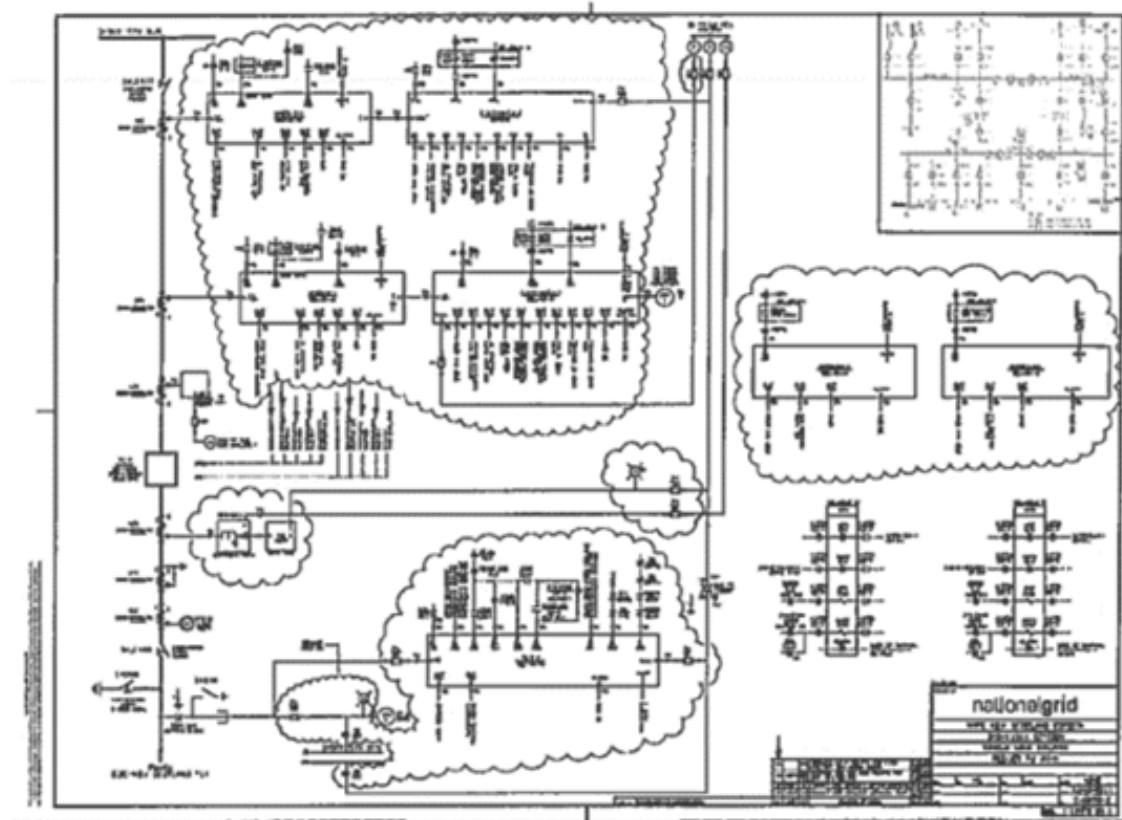

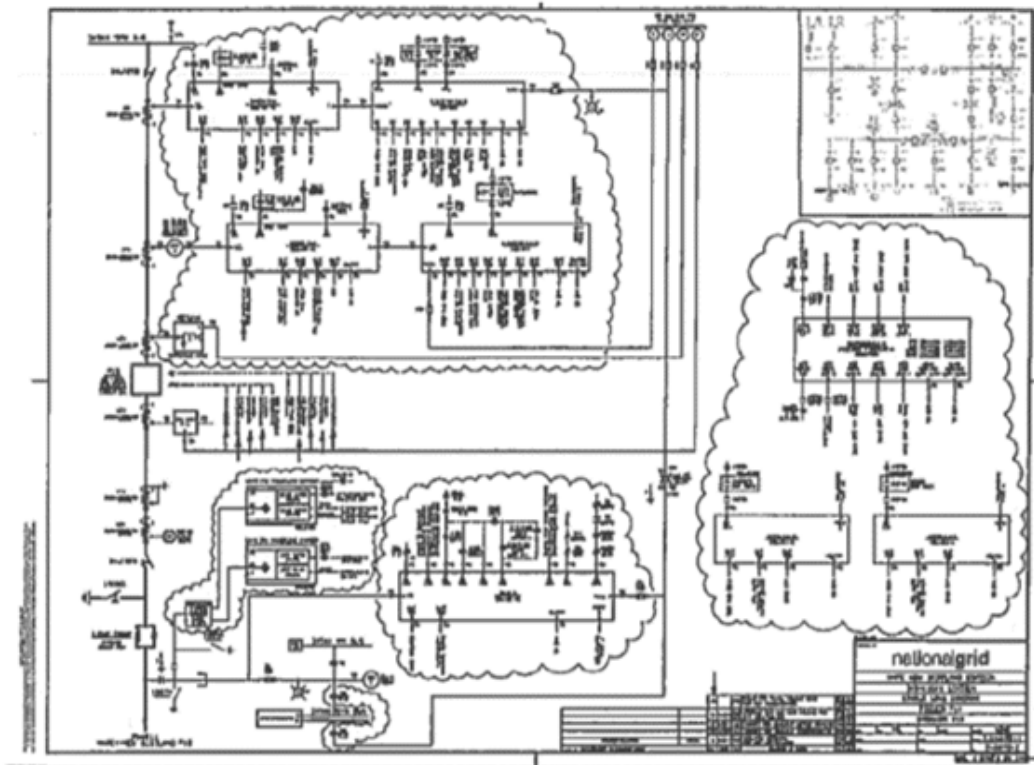
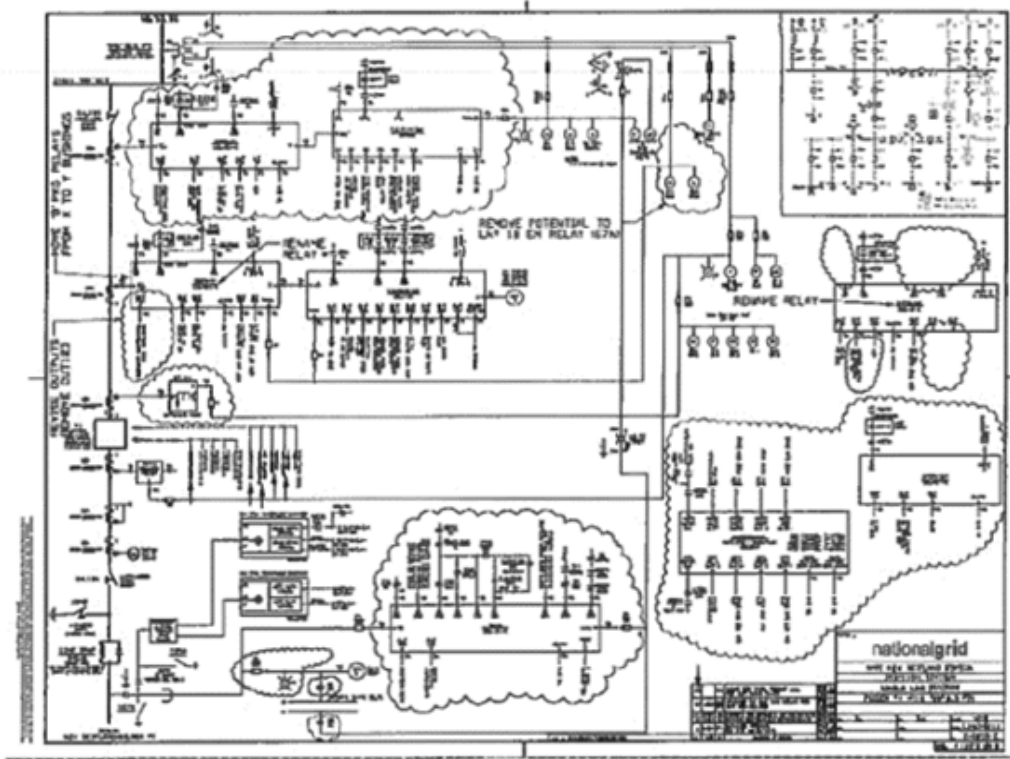

III. Volney Station work – Original Scope

Volney-Marcy Line 19 will need additional relaying upgrades.

Protection

Replace existing ‘B’ protection package with a microprocessor based series compensated line protection package;

Control & Integration (C&I)

Reuse existing RTU / EMS points

Assumptions, Clarifications and Exceptions

This Scope assumes that the existing Volney control house panels have space for additional equipment and that the existing above-referenced RTU / EMS has spare points for use.

IIIA. Volney Station – Updated Scope

The Volney-Marcy Line 19 protective relays have been designed and installed as of 5/13/15 as follows.

The existing B line protection relay (SEL-321) has been replaced with an SEL-421-5 with series compensation settings capabilities. The relay has been programmed and placed in service.

The existing A line protection relay (ERL Phase LPro-2100) has been reprogrammed with new settings to accommodate the series compensation.

IIIB. Volney Station Cost Estimate

Company Field Labor = \$27,000

Company Project Management and Engineering = \$12,000

Contract Labor = \$16,000

Materials = \$8,000

Transportation/Equipment = \$3,000

Other = \$1,000

Company Overheads and Costs = \$15,000

Contingency (5%) = \$4,000

TOTAL = \$86,000

IV. Clay Station work – Original Scope

Edic-Clay Lines 15 and 16

Protection

Replace existing 'B' protection package with a microprocessor based series compensated line protection package at each terminal.

IVA. Clay Station Updated Scope

1. The Edic-Clay Lines 2-15 and 1-16 protective relays have been designed and installed as of 5/27/15 as follows.

The B line protection relay on each line has been replaced with an SEL-421-5 with series compensation settings capabilities. The relays have been programmed and placed in service.

The existing A line protection relay on each line (ERL Phase LPro-2100) has been reprogrammed with new settings to accommodate the series compensation.

IVB. Clay Station Updated Estimate

Company Field Labor = \$59,000
Company Project Management and Engineering = \$10,000
Contract Labor = \$20,000
Materials = \$25,000
Transportation/Equipment = \$7,000
Other = \$1,000
Company Overheads and Costs = \$34,000
Contingency (5%) = \$8,000

TOTAL = \$167,000

DISTRIBUTION LINE INTERFERENCE MODIFICATION

For modification to our distribution system to remove a potential high voltage line interference related to changes caused by the MSSC Project affecting NYPA's 345 kV UCCs-41 transmission line.;

1. Scope: National Grid will modify the distribution line by lowering the crossarm on our structure #4 a distance of three feet, and installing an intermediate pole
2. Estimated Cost for proposed scope:

Labor = \$4800

Transportation = \$500

Materials = \$1100

Company Overheads = \$1600

Total Estimated Cost = \$8000

V. TOTAL REVISED and UPDATED NATIONAL GRID PROJECT ESTIMATE

Edic Station Estimate = \$2,602,000

New Scotland Station Estimate = \$1,250,000

Volney Station Estimate = \$167,000

Distribution Line Interference Modification = \$8,000

Total Revised and Updated Project Estimate = \$4,113,000

;

;

Schedule B: Projected Milestone Schedule

PROJECTED MILESTONE SCHEDULE*

Task	Milestone	Date	Responsible Party
1.	Execute Agreement	November 21, 2014	Customer/Company
2.	Invoice and Payment of Initial Prepayment	November 26, 2014	Customer/Company
3.	Start Part 1 (Preliminary Engineering & Design Work)	December 12, 2014	Company
4.	Complete Part 1	March 1, 2015	Company
5.	Delivery of Consent to Proceed with Part 2 (Implementation Work)	March 15, 2015	Customer
6.	Complete Final Engineering, Design and Procurement	February 15, 2016	Company
7.	Start Construction	March 1, 2016	Company
8.	Complete testing; become operational	June 30, 2016	Company

* Company, under a separate project (and not as part of the Work and at no cost to the Customer), may elect to design and construct a new control house building at Edic Station, any such project will have a direct relationship to, and may result in delays in, the Work and the preliminary schedule contemplated by this Schedule B.

The dates above represent the Parties' preliminary schedule, which is subject to adjustment, alteration, and extension in accordance with the terms of this Agreement.

Schedule C: Customer's Responsibilities

Customer shall provide:

1. If and to the extent applicable or under the control of the Customer, complete and accurate information regarding requirements for Work, including, without limitation, constraints, space, requirements, underground or hidden facilities and structures, and all applicable drawings and specifications; and
2. At Sites where Customer has site control, provide access to the Site where services are to be performed for Company and its contractors and adequate parking for Company and contractor vehicles; and.
3. Other responsibilities and access deemed necessary by Company to facilitate performance of the Work

Schedule D: Insurance Requirements

- Workers Compensation and Employers Liability Insurance as required by the State of **New York**. If required, coverage shall include the U.S. Longshoremen's, Harbor Workers Compensation Act & the Jones Act.
 - Commercial General Liability (Including Contractual Liability), covering all activities and operations to be performed by it under this Agreement, with following minimum limits:
 - (A) Bodily Injury - \$1,000,000/\$1,000,000
Property Damage - \$1,000,000/\$1,000,000
OR
 - (B) Combined Single Limit - \$1,000,000
OR
 - (C) Bodily Injury and Property Damage per Occurrence - \$1,000,000
General Aggregate & Product Aggregate - \$2,000,000 each
 - Umbrella or Excess Liability, coverage with a minimum limit of \$ 4,000,000.
1. Upon request, either Party shall promptly provide the requesting Party with either evidence of insurance or certificates of insurance evidencing the insurance coverage above. Customer shall provide such certificates or evidence of insurance to Company at the following address:

To: National Grid c/o NIAGARA MOHAWK POWER CORPORATION
Attention: Risk Management, A-4
300 Erie Boulevard West
Syracuse, NY 13202

Company shall provide such certificates or evidence of insurance to Customer at the following address:

To: Procurement Department
123 Main Street
White Plains, NY 10601
 2. Should any of the above described policies be cancelled before the expiration date thereof, notice will be delivered in accordance with the policy provisions.
 3. If a party fails to secure or maintain any insurance coverage, or any insurance coverage is canceled before the completion of all services provided under this Agreement, and such party fails immediately to procure such insurance as specified herein, then the non-defaulting party has the right but not the obligation to procure such insurance and, at its option, either bill the cost thereof to the defaulting party or deduct the cost thereof from any sum due the defaulting party under this Agreement.
 4. To the extent requested, both Parties shall furnish to each other with copies of any accidents report(s) sent to the a party's insurance carriers covering accidents or incidents occurring in connection with or as a result of the performance of the Work for the Project under this Agreement.

5. Each Party shall comply with any governmental and/or site specific insurance requirements even if not stated herein.
6. By the date that such coverage is required, each Party represents to the other that it will have full policy limits available and shall notify each other in writing when coverage's required herein have been reduced as a result of claim payments, expenses, or both.

Schedule E: Prompt Payment Policy

A. GENERAL

1. This statement is intended to establish rules and regulations as required under Section 2880 of the Public Authorities Law describing the policy of the Power Authority of the State of New York (the "Authority") to promptly pay all proper invoices submitted by any Contractor. Subject to the conditions and exceptions set forth in Section 2880 and herein, in the event any proper invoice is not paid promptly, the Authority shall be liable for the payment of interest on late payments. This policy shall apply to all Contracts entered into on or after April 30, 1988.

B. DEFINITIONS

1. "CONTRACT" means an enforceable agreement entered into between the Authority and a Contractor.
2. "CONTRACTOR" means any person, partnership, private corporation or association: a) selling materials, equipment or supplies or leasing property or equipment to the Authority; b) constructing, reconstructing or repairing buildings, highways or other improvements for or on behalf of the Authority; or c) rendering or providing services to the Authority pursuant to a Contract.
3. "DESIGNATED PAYMENT OFFICE" means the office designated by the Authority to which a proper invoice is to be submitted by a Contractor.
4. "PROPER INVOICE" means a written request for a Contract Payment that is submitted by a Contractor to the Authority's designated payment office setting forth the description, price and quantity of goods, property or services delivered or rendered in accordance with the terms of the Contract, in such form and supported by such other substantiating documentation as the Authority may reasonably require.
5. "RECEIPT OF AN INVOICE" and "INVOICE RECEIVED DATE" mean (a) the date on which proper invoice is actually received in the designated payment office, or (b) the date on which the Authority receives the purchased goods, property or services covered by the proper invoice, whichever is later. With regard to final payments on construction contracts, (b) shall mean the date on which all the Contract Work has been accepted as completed by the Authority in accordance with the Contract terms.
6. "SET-OFF" means the reduction by the Authority of a payment due a Contractor by an amount equal to the amount of an unpaid legally enforceable debt owed by the Contractor to the Authority.

C. RESPONSIBILITY FOR PROMPT PAYMENT

1. The Authority's Controller shall have the responsibility for the implementation of the Prompt Payment Policy and the prompt payment of all proper invoices under the general guidance and supervision of the Executive Vice President & Chief Financial Officer.

D. PROMPT PAYMENT PROCEDURE

1. A Contractor shall request payment under a Contract by submitting a proper invoice to the Authority at its designated payment office at the time and in the manner specified in the Contract.
2. The Authority shall have fifteen (15) calendar days after receipt of an invoice at its designated payment office to notify the Contractor of certain facts and conditions, including but not limited to those listed below, which, in the opinion of the Authority's Controller, justify extension of the statutory payment period.
 - a) there is a defect in the delivered goods, property or services;
 - b) there is a defect in the invoice;
 - c) there are suspected defects or improprieties of any kind the existence of which prevent the commencement of the statutory payment period;
 - d) prior to payment, a statutory or contractual provision requires an inspection period or an audit to determine the resources applied or used by the Contractor in fulfilling the contract terms;
 - e) a proper invoice must be examined by the federal government prior to payment;
 - f) the Authority is prevented from making payment by reason of the filing of a lien, attachment, other legal process or requirement of law.

Any time taken to satisfy or rectify any such facts or conditions shall extend the date by which contract payment must be made in order for the Authority not to become liable for interest payments by an equal period of time.

3. Should the Authority fail to notify a Contractor of such facts and conditions within fifteen calendar days of the invoice received date, the number of days allowed for payment of the corrected proper invoice will be reduced by the number of days between the fifteenth day and the day that notification was transmitted to the Contractor. Should the Authority, in such situations, fail to provide reasonable grounds for its contention that a fact or condition justifying a time extension exists, the date by which contract payment must be made in order for the Authority not to become liable for interest payment shall be calculated from the invoice received date.
4. The Authority shall make payment within forty five (45) calendar days after the invoice received date. Effective July 1, 1989, the Authority shall make payment within thirty (30) calendar days, excluding legal holidays, after invoice received dates occurring after that date.
5. Except for the payments described in Paragraph E, every payment by the Authority to a Contractor pursuant to a Contract is eligible for interest should the Authority fail to make such payment within forty five (45) days after the invoice received date for contracts entered into between April 30, 1988 and June 30, 1989 and within thirty (30) days for contracts entered into on or after July 1, 1989.
6. The Authority shall not be liable for interest on any retention amounts withheld by the Authority in accordance with the terms of the Contract.
7. Interest shall be computed at the rate set by the state tax commission for corporate taxes pursuant to paragraph one of subsection (e) of section 1096 of the tax law, but the Authority shall not be liable for payment of interest when such interest is less than ten dollars.
8. The Authority has available funds in its custody to pay all interest penalties.

E. EXCEPTIONS

1. Payments are not eligible for interest when they are due and owing by the Authority:
 - a) under the eminent domain procedure law;
 - b) as interest allowed on a judgement by a court pursuant to any provision of law other than section 2880 of the Public Authorities Law;
 - c) to the federal government; to any state agency or its instrumentalities; to any duly constituted unit of local government including but not limited to, counties, cities, towns, villages, school districts, or any of their related instrumentalities; to any other public authority or public benefit corporation; or to its employees when acting in, or incidental to, their public employment capacity;
 - d) in situations where the Authority exercises a legally authorized set-off against all or part of the payment due the Contractor.