

Attachment B

COST REIMBURSEMENT AGREEMENT

Between

**NIAGARA MOHAWK POWER CORPORATION
d/b/a National Grid**

and

ROCHESTER GAS AND ELECTRIC CORPORATION

(NYISO OATT Service Agreement No. 2135)

COST REIMBURSEMENT AGREEMENT

This **COST REIMBURSEMENT AGREEMENT** (the “*Agreement*”), is made and entered into as of March 31, 2014 (the “*Effective Date*”), by and between **ROCHESTER GAS AND ELECTRIC CORPORATION**, a utility organized and existing under the laws of NEW York State, having an office and place of business at 89 East Avenue Rochester, NY 14604 (“*Customer*” or “*RG&E*”) and **NIAGARA MOHAWK POWER CORPORATION d/b/a National Grid**, a corporation organized and existing under the laws of the State of New York, having an office and place of business at 300 Erie Boulevard West, Syracuse, New York 13202 (the “*Company*” or “*National Grid*”). Customer and Company may be referred to hereunder, individually, as a “*Party*” or, collectively, as the “*Parties*”.

WITNESSETH

WHEREAS, Customer has requested that Company perform certain Work with respect to Mortimer Station, Station 251 and related portions of transmission lines/circuits and equipment located inside the property line of the impacted National Grid Stations as described herein; and

WHEREAS, Company is willing to perform the Work, subject to reimbursement by Customer of all Company costs and expenses incurred in connection therewith;

NOW, THEREFORE, in consideration of the premises and the mutual covenants set forth herein, the Parties agree as follows:

1.0 Certain Definitions

Wherever used in this Agreement with initial capitalization, whether in the singular or the plural, these terms shall have the following meanings:

“*Affiliate*” means any person or entity controlling, controlled by, or under common control with, any other person; “control” of a person or entity shall mean the ownership of, with right to vote, 50% or more of the outstanding voting securities, equity, membership interests, or equivalent, of such person or entity.

“*Agreement*” means this Cost Reimbursement Agreement, including all annexes, appendices, attachments, schedules, and exhibits and any subsequent written amendments or modifications thereto, as may be mutually agreed to and executed by the Parties.

“*Applicable Requirements*” shall mean all applicable federal, state and local laws, regulations, rules, ordinances, codes, decrees, judgments, directives, or judicial or administrative orders, permits and other duly authorized actions of any federal, state, local or other governmental regulatory or administrative agency, court, commission, department, board, or other governmental subdivision, legislature, rulemaking board, tribunal, or other

governmental authority having jurisdiction, NYISO, NPCC, and NYSRC requirements, and any applicable reliability standards.

“Balance Amount” shall have the meaning set forth in Section 8.1 of this Agreement.

“Breaching Party” shall have the meaning set forth in Section 21.1 of this Agreement.

“CEIF” shall have the meaning set forth in Section 25.4 of this Agreement.

“Company Reimbursable Costs” means the actual costs and expenses incurred by Company and/or its Affiliates in connection with performance of the Work or otherwise incurred by Company and/or its Affiliates in connection with the Project or this Agreement, and including, without limitation, any such costs that may have been incurred by Company and/or its Affiliates prior to the Effective Date. These Company Reimbursable Costs shall include, without limitation, the actual expenses for labor (including, without limitation, internal labor), services, materials, subcontracts, equipment or other expenses incurred in the execution of the Work or otherwise in connection with the Project, all applicable overhead, all federal, state and local taxes incurred (including, without limitation, all taxes arising from amounts paid to Company that are deemed to be contributions in aid of construction), all costs of outside experts, consultants, counsel and contractors, all other third-party fees and costs, and all costs of obtaining any required permits, rights, consents, releases, approvals, or authorizations, including, without limitation, the Required Approvals.

“Damages” shall have the meaning set forth in Section 12.1 of this Agreement.

“Day” means a calendar day, provided, that, if an obligation under this Agreement falls due on a Saturday, Sunday or legal holiday, the obligation shall be due the next business day worked.

“Disclosing Party” shall mean the Party disclosing Proprietary Information.

“Dollars” and “\$” mean United States of America dollars.

“Effective Date” shall have the meaning specified in the preamble of this Agreement.

“Environment” shall mean soil, surface waters, groundwaters, land, stream sediments, surface or subsurface strata, and ambient air.

“Environmental Law” shall mean any environmental or health-and-safety-related law, regulation, rule, ordinance, or by-law at the federal, state, or local level, whether existing as of the Effective Date, previously enforced or subsequently enacted, or any judicial or administrative interpretation thereof.

“FERC” shall mean the Federal Energy Regulatory Commission.

“Force Majeure Event” shall have the meaning set forth in Section 23.1 of this Agreement.

“Good Utility Practice” means any of the practices, methods, and acts engaged in or approved by a significant portion of the electric utility industry during the relevant time period, or any of the practices, methods, and acts which, in the exercise of reasonable judgment in light of the facts known at the time the decision was made, could have been expected to accomplish the desired result at a reasonable cost consistent with good business practices, reliability, safety, and expedition. Good Utility Practice is not intended to be limited to the optimum practice, method, or act, to the exclusion of all others, but rather to refer to acceptable practices, methods, or acts generally accepted in the region in which the Project is located. Good Utility Practice shall include, but not be limited to, NERC, NPCC, NYSRC, and NYISO criteria, rules, guidelines, and standards, where applicable, and as they may be amended from time to time, including the rules, guidelines, and criteria of any successor organization to the foregoing entities.

“Hazardous Substances” means any pollutant, contaminant, toxic substance, hazardous material, hazardous waste, or hazardous substance, or any oil, petroleum, or petroleum product, as defined in or pursuant to the Federal Clean Water Act, as amended, the Comprehensive Environmental Response, Compensation and Liability Act, as amended, 42 U.S.C. Section 9601, et seq., the Resource Conservation and Recovery Act, as amended, 42 U.S.C. Section 6901, et seq., or any other Environmental Law.

“Indemnified Party” and “Indemnified Parties” shall have the meanings set forth in Section 12.1 of this Agreement.

“Indemnifying Party” shall have the meaning set forth in Section 12.1 of this Agreement.

“Initial Prepayment” shall have the meaning set forth in Section 7.1 of this Agreement.

“Monthly Report” shall have the meaning set forth in Section 7.3 of this Agreement.

“NPCC” shall mean the Northeast Power Coordinating Council, Inc. (a reliability council under Section 202 of the Federal Power Act) or any successor organization.

“NERC” shall mean the North American Electric Reliability Corporation or any successor organization.

“Non-Breaching Party” shall have the meaning set forth in Section 21.1 of this Agreement.

“Non-Disclosure Term” shall have the meaning set forth in Section 25.3.4 of this Agreement.

“NYISO” shall mean the New York Independent System Operator, Inc. or any successor organization.

“NYPSC” shall mean the New York Public Service Commission.

“NYSRC” shall mean the New York State Reliability Council or any successor organization.

“Party” and “Parties” shall have the meanings set forth in the preamble to this Agreement.

“Projected Milestone Schedule” shall have the meaning set forth in Section 5.3 of this Agreement.

“Project” means the Work to be performed under this Agreement by the Company.

“Project Manager” means the respective representative of the Customer and the Company appointed pursuant to Section 27.1 of this Agreement.

“Proprietary Information” means (i) all financial, technical and other non-public or proprietary information which is furnished or disclosed by the Disclosing Party or its Affiliates (or its or its Affiliates’ agents, servants, contractors, representatives, or employees) to the Receiving Party or its Representative(s) in connection with this Agreement and that is described or identified (at the time of disclosure) as being non-public, confidential or proprietary, or the non-public or proprietary nature of which is apparent from the context of the disclosure or the contents or nature of the information disclosed, (ii) any market sensitive information (including, without limitation, outages scheduled on generators or transmission lines of Company or any third party), (iii) all CEII and (iv) all memoranda, notes, reports, files, copies, extracts, inventions, discoveries, improvements or any other thing prepared or derived from any information described in subparts (i) through (iii) preceding.

“Receiving Party” shall mean the Party receiving Proprietary Information.

“Reimbursement Amount” shall have the meaning set forth in Section 8.1 of this Agreement.

“Release” shall mean any releasing, spilling, leaking, contaminating, pumping, pouring, emitting, emptying, discharging, injecting, escaping, leaching, disposing or dumping of any Hazardous Substances into the Environment.

“Representatives” shall, for the purposes of Article 25 of this Agreement, mean the Affiliates of a Party and such Party’s and its Affiliates’ officers, directors, employees, contractors, counsel and representatives.

“Requesting Party” shall have the meaning set forth in the Real Property Standards.

“Required Approvals” shall have the meaning set forth in Section 27.12 of this Agreement.

“Resources” shall have the meaning set forth in Section 23.1 of this Agreement.

“Threat of Release” shall mean a substantial likelihood of a Release that requires action to prevent or mitigate damage to the Environment that may result from such Release.

“Site” shall mean Luther Forest Station.

“*Subcontractor*” means any organization, firm or individual, regardless of tier, which Company retains in connection with the Agreement.

“*Total Payments Made*” shall have the meaning set forth in Section 8.1 of this Agreement.

“*Work*” shall have the meaning specified in Section 3.1 of this Agreement.

“*Work Cost Estimate*” shall have the meaning set forth in Section 6.1 of this Agreement.

2.0 Term

2.1 This Agreement shall become effective as of the Effective Date and shall remain in full force and effect until performance has been completed hereunder, or until terminated in accordance with the terms of this Agreement, whichever occurs first, provided, however, that this Agreement shall not expire or terminate until all amounts due and owing hereunder have been paid in full as contemplated by this Agreement.

3.0 Scope of Work

3.1 The scope of work is set forth in Exhibit A of this Agreement, attached hereto and incorporated herein by reference (the “*Work*”).

3.2 Company shall use commercially reasonable efforts to perform the Work in accordance with Good Utility Practice. Prior to the expiration of one (1) year following completion of the Work, Customer shall have the right to notify the Company of the need for correction of defective Work that does not meet the standards of this Section 3.2. If the Work is defective within the meaning of the prior sentence, the Company shall promptly complete, correct, repair or replace such defective Work, as appropriate. The remedy set forth in this Section is the sole and exclusive remedy granted to Customer for any failure of Company to meet the performance standards or requirements set forth in this Agreement.

4.0 Changes in the Work

4.1 Prior to commencement of the Work, each Party shall provide a written notice to the other Party containing the name and contact information of such Party’s Project Manager.

- 4.2 If Customer wishes to request a change in the Work, such request shall be submitted to the Company in writing. If, as a result of any such request, the Parties agree to a change in the Work, the agreed change will be set forth in a written document signed by both Parties specifying such change. The Projected Milestone Schedule and the Work Cost Estimate shall be adjusted and/or extended as mutually agreed by the Parties to reflect any such agreed change to the Work. Any additional costs arising from such change shall be paid by the Customer as part of Company Reimbursable Costs when invoiced by the Company in accordance with Section 7.2 of this Agreement.
- 4.3 Notwithstanding the above, Company may make any reasonable changes in the Work to ensure the completion of the Project or prevent delays in the schedule. Company shall provide Customer with written notice of any such changes to the Work within fifteen (15) business days after such changes are implemented. The Projected Milestone Schedule and the Work Cost Estimate shall be adjusted accordingly and any additional costs shall be paid by the Customer as part of Company Reimbursable Costs when invoiced by the Company in accordance with Section 7.2 of this Agreement.

The foregoing notwithstanding, the Company is not required to obtain the consent of the Customer for any change to the Work if such change is made in order to comply with any Applicable Requirement(s) or Good Utility Practice or to enable Company's utility facilities to continue, commence or recommence commercial operations in accordance with all applicable legal and regulatory requirements and all applicable industry codes and standards. The Projected Milestone Schedule and the Work Cost Estimate shall be adjusted accordingly and any additional costs shall be paid by the Customer as part of Company Reimbursable Costs when invoiced by the Company in accordance with Section 7.2 of this Agreement.

5.0 Performance and Schedule; Conditions to Proceed

- 5.1 The Company shall use commercially reasonable efforts to have any Work performed by its direct employees performed during normal working hours. The foregoing notwithstanding, if Work is performed outside of normal working hours, Customer shall be responsible for paying all actual costs incurred in connection therewith, including, without limitation, applicable overtime costs, as part of Company Reimbursable Costs. The Company shall provide the Customer with prior notification when work outside of normal working hours is required.
- 5.2 If Customer requests, and the Company agrees, to work outside normal working hours due to delays in the Project schedule or for other reasons, Company shall be entitled to recover all resulting costs as part of Company Reimbursable Costs.
- 5.3 The Projected Milestone Schedule is set forth in Exhibit B, attached hereto and incorporated herein by reference. The Projected Milestone Schedule is a projection only and is subject to change. Both Parties shall make reasonable efforts to adhere to the Projected Milestone Schedule. Neither Party shall be liable

for failure to meet the Preliminary Milestone Schedule, any milestone, or any other projected or preliminary schedule in connection with this Agreement or the Project.

5.4 Anything in this Agreement to the contrary notwithstanding, Company shall not be obligated to proceed with any Work until all of the following conditions have been satisfied:

- (i) all Required Approvals for the Work have been received, are in form and substance satisfactory to the Parties, have become final and non-appealable and commencement of the Work is permitted under the terms and conditions of such Required Approvals, and
- (ii) all Company Reimbursable Costs invoiced to date have been paid in full to Company.

6.0 Estimate Only; Customer Obligation to Pay Company Reimbursable Costs.

6.1 The current good faith estimate of the Company Reimbursable Costs, exclusive of any applicable taxes, is One Million Three Hundred Thousand Dollars (\$1,300,000) (the "Work Cost Estimate"). The Work Cost Estimate is an estimate only and shall not limit Customer's obligation to pay Company for all Company Reimbursable Costs actually incurred by Company or its Affiliates.

7.0 Payment

7.1 Customer shall pay or reimburse Company for all Company Reimbursable Costs. The Company has previously~~shall~~ invoiced Customer for, and Customer has paid, an initial prepayment of One Hundred ~~and~~ Fifty Thousand dollars (\$150,000) (the "~~Prior~~Initial Prepayment")~~, and Customer shall pay the Initial Prepayment to Company within thirty (30) Days of the invoice due date.~~ Company shall invoice Customer for an additional prepayment of Five Hundred Thousand Dollars (\$500,000) (the "Additional Prepayment", and, together with the Prior Prepayment, the "Initial Prepayment") and Customer shall pay the Additional Prepayment to Company within thirty (30) Days of the invoice due date. Company shall not be obligated to commence or continue Work under this Agreement, as amended, prior to receiving payment in full of the Initial Prepayment.

7.2 Company may periodically invoice Customer for Company Reimbursable Costs incurred. Each invoice will contain reasonable detail sufficient to show the invoiced Company Reimbursable Costs incurred by line item. Company is not required to issue periodic invoices to Customer and may elect, in its sole discretion, to continue performance hereunder after the depletion of the Initial Prepayment or any subsequent prepayment, as applicable, and invoice Customer at a later date. Except as otherwise expressly provided for in this Agreement, all invoices shall be due and payable thirty (30) Days from date of invoice. If any

payment due under this Agreement is not received within thirty (30) Days after the applicable invoice due date, the Customer shall pay to the Company interest on the unpaid amount at an annual rate equal to two percent (2%) above the prime rate of interest from time to time published under "Money Rates" in The Wall Street Journal (or if at the time of determination thereof, such rate is not being published in The Wall Street Journal, such comparable rate from a federally insured bank in New York, New York as the Company may reasonably determine), the rate to be calculated daily from and including the due date until payment is made in full. In addition to any other rights and remedies available to Company, if any payment due from Customer under this Agreement is not received within thirty (30) Days after the applicable invoice due date, Company may suspend any or all Work pending receipt of all amounts due from Customer; any such suspension shall be without recourse or liability to Company.

- 7.3 Each month during the term of this Agreement, the Company shall provide Customer with a report (each, a "Monthly Report") containing (i) unless invoiced, the Company's current estimate of the Company Reimbursable Costs incurred in the prior calendar month, and (ii) the Company's current forecast (20% to 40% variance) of the Company Reimbursable Costs expected to be incurred in the next calendar month, provided, however, that such Monthly Reports (and any forecasted or estimated amounts reflected therein) shall not limit Customer's obligation to pay Company for all Company Reimbursable Costs actually incurred by Company or its Affiliates.
- 7.4 If Customer claims exemption from sales tax, Customer agrees to provide Company with an appropriate, current and valid tax exemption certificate, in form and substance satisfactory to National Grid, relieving National Grid from any obligation to collect sales taxes from Customer ("Sales Tax Exemption Certificate"). During the term of this Agreement, Customer shall promptly provide National Grid with any modifications, revisions or updates to the Sales Tax Exemption Certificate or to Customer's exemption status. If Customer fails to provide an acceptable Sales Tax Exemption Certificate for a particular transaction, National Grid shall add the sales tax to the applicable invoice to be paid by Customer.
- 7.5 Company shall maintain reasonably detailed records to document the Company Reimbursable Costs. So long as a request for access is made within six (6) months of completion of the Work, Customer and its chosen auditor shall, during normal business hours and upon reasonable advanced written notice of not less than ten (10) days, be provided with access to such records for the sole purpose of verification by Customer that the Company Reimbursable Costs have been incurred by Company.

7.6 Company's invoices to Customer for all sums owed under this Agreement shall be sent to the individual and address specified below, or to such other individual and address as Customer may designate, from time to time, by written notice to the Company :

Name: Mr. David Fingado
Address: RG&E
1300 Scottsville Road
Rochester, NY 14624

7.7 All payments made under this Agreement shall be made in immediately available funds. Payments to the Company shall be made by wire transfer to:

Wire Payment: JP Morgan Chase
ABA#: 021000021
Credit: National Grid USA
Account#: 77149642

8.0 Final Payment

8.1 Following completion of the Work, the Company shall perform an overall reconciliation of the total of all Company Reimbursable Costs to the invoiced costs previously paid to Company by Customer under this Agreement ("*Total Payments Made*"). If the total of all Company Reimbursable Costs is greater than the Total Payments Made, the Company shall provide a final invoice to Customer for the balance due to the Company under this Agreement (the "*Balance Amount*"). If the Total Payments Made is greater than the total of all Company Reimbursable Costs, Company shall reimburse the difference to Customer ("*Reimbursement Amount*"). The Reimbursement Amount or Balance Amount, as applicable, shall be due and payable upon final reconciliation but no later than sixty (60) Days after such reconciliation. Any portion of the Balance Amount or Reimbursement Amount, as applicable, remaining unpaid after that time shall be subject to interest as calculated pursuant to Section 7.2 of this Agreement.

9.0 Customer's Responsibilities

9.1 If and to the extent applicable or under the control of the Customer, Customer shall provide complete and accurate information regarding requirements for the Project and the Site(s), including, without limitation, constraints, space requirements, underground or hidden facilities and structures, and all applicable drawings and specifications.

9.2 Customer shall prepare, file for, and use commercially reasonable efforts to obtain all Required Approvals necessary to perform its obligations under this Agreement.

- 9.3 Customer shall reasonably cooperate with Company as required to facilitate Company's performance of the Work, including, without limitation, performance of any work or tasks to be performed by Customer as contemplated by Exhibit A of this Agreement.

10.0 Meetings

- 10.1 Each Party's Project Manager shall attend Project meetings at times and places mutually agreed to by the Parties, which meetings shall be held at least monthly by teleconference or in person as agreed to by the Project Managers.

11.0 Disclaimers

- 11.1 THE COMPANY IS NOT IN THE BUSINESS OF PERFORMING DESIGN, ENGINEERING OR CONSTRUCTION SERVICES FOR PROFIT AND IS NOT RECEIVING ANY FEE OR PROFIT (AS CONTRASTED WITH COST REIMBURSEMENT) FOR ITS PERFORMANCE OF THE WORK HEREUNDER. THE EXCLUSIVE REMEDY GRANTED TO CUSTOMER FOR ANY ALLEGED FAILURE OF COMPANY TO MEET THE PERFORMANCE STANDARDS OR REQUIREMENTS CONTAINED IN THIS AGREEMENT IS AS SET FORTH IN SECTION 3.2. COMPANY MAKES NO WARRANTIES, REPRESENTATIONS, OR GUARANTEES IN CONNECTION WITH THIS AGREEMENT, ANY PROJECT, OR ANY WORK OR SERVICES PERFORMED IN CONNECTION THEREWITH, WHETHER WRITTEN OR ORAL, STATUTORY, EXPRESS OR IMPLIED, INCLUDING, WITHOUT LIMITATION, THE IMPLIED WARRANTIES OF MERCHANTABILITY AND FITNESS FOR A PARTICULAR PURPOSE, ALL OF WHICH ARE HEREBY EXPRESSLY EXCLUDED AND DISCLAIMED. CUSTOMER ACKNOWLEDGES AND AGREES THAT ANY WARRANTIES PROVIDED BY ORIGINAL MANUFACTURERS, LICENSORS, OR PROVIDERS OF MATERIAL, EQUIPMENT, SERVICES OR OTHER ITEMS PROVIDED OR USED IN CONNECTION WITH THE WORK, INCLUDING ITEMS INCORPORATED IN THE WORK ("THIRD PARTY WARRANTIES"), ARE NOT TO BE CONSIDERED WARRANTIES OF THE COMPANY AND THE COMPANY MAKES NO REPRESENTATIONS, GUARANTEES, OR WARRANTIES AS TO THE APPLICABILITY OR ENFORCEABILITY OF ANY SUCH THIRD PARTY WARRANTIES.

- 11.2 Notwithstanding any other provision of this Agreement, this Article shall survive the termination, cancellation or expiration of this Agreement.

12.0 Liability and Indemnification

- 12.1 To the fullest extent permitted by applicable law (including, without limitation, the applicable provisions of any governing federal or state tariff), Customer shall indemnify and hold harmless, and at Company's option, defend Company, its parents and Affiliates and their respective contractors, officers, directors, servants, agents, representatives, and employees (each, individually, an "Indemnified Party" and, collectively, the "Indemnified Parties"), from and against any and all liabilities, damages, losses, costs, expenses (including, without limitation, any and all reasonable attorneys' fees and disbursements), causes of action, suits, liens, claims, damages, penalties, obligations, demands or judgments of any nature, including, without limitation, for death, personal injury and property damage, economic damage, and claims brought by third parties for personal injury and/or property damage (collectively, "Damages"), incurred by any Indemnified Party to the extent caused by (i) any breach of this Agreement by Customer, its Affiliates, third-party contractors, or their respective officers, directors, servants, agents, representatives, or employees, or (ii) the negligence, unlawful act or omission, or intentional misconduct of Customer, its Affiliates, third-party contractors, or their respective officers, directors, servants, agents, representatives, and employees, arising out of or in connection with this Agreement, the Project, or any Work, except to the extent such Damages are directly caused by the gross negligence, intentional misconduct or unlawful act of the Indemnified Party or its contractors, officers, directors, servants, agents, representatives, or employees.
- 12.2 Customer shall defend, indemnify and save harmless Company, its parents and Affiliates and their respective contractors, officers, directors, servants, agents, representatives, and employees, from and against any and all liabilities, losses, costs, counsel fees, expenses, damages, judgments, decrees and appeals resulting from any charge or encumbrance in the nature of a laborer's, mechanic's or materialman's lien asserted by any of Customer's subcontractors or suppliers in connection with the Work or the Project.
- 12.3 Customer shall also protect, indemnify and hold harmless the Company and its Affiliates from and against the cost consequences of any tax liability imposed against or on Company and/or its Affiliates as the result of payments, and/or real or personal property transfers, made in connection with this Agreement, as well as any related interest and penalties, other than interest and penalties attributable to any delay directly caused by Company or the applicable Company Affiliate.
- 12.4 The Company's total cumulative liability to Customer for all claims of any kind, whether based upon contract, tort (including negligence and strict liability), or otherwise, for any loss, injury, or damage connected with, or resulting from, this Agreement, the Project or the Work, shall not exceed the aggregate amount of all payments made to Company by Customer as Company Reimbursable Costs under this Agreement.

- 12.5 Neither Party shall be liable to the other Party for consequential, indirect, special, incidental, multiple, or punitive damages (including, without limitation, attorneys' fees or litigation costs) in connection with or related to this Agreement, including, without limitation, damage claims based on causes of action for breach of contract, tort (including negligence), or any other theory of recovery, whether or not (i) such damages were reasonably foreseeable or (ii) the Parties were advised or aware that such damages might be incurred.
- 12.6 Neither Party shall be liable to the other Party for claims or damages for lost profits, delays, loss of use, business interruption, or claims of customers, whether such claims are categorized as direct or consequential damages, or whatever the theory of recovery, and whether or not (i) such damages were reasonably foreseeable or (ii) the Parties were advised or aware that such damages might be incurred.
- 12.7 Anything in this Agreement to the contrary notwithstanding, neither Party shall be responsible for any failure or inability to perform hereunder to the extent such failure or inability is caused by the acts or omissions of the other Party (including any contractor of such Party or any person or entity for whom such Party is legally responsible) or of any third party (other than a subcontractor of the Party that is unable or failing to perform hereunder).

For the avoidance of doubt: neither Party, as applicable, shall have any responsibility or liability under this Agreement for any delay in performance or nonperformance to the extent such delay in performance or nonperformance is caused by or as a result of (a) the inability or failure of the other Party or its contractors to cooperate or to perform any tasks or responsibilities contemplated to be performed or undertaken by such other Party under this Agreement, (b) any unforeseen conditions or occurrences beyond the reasonable control of the Party (including, without limitation, conditions of or at the Site, delays in shipments of materials and equipment and the unavailability of materials), (c) the inability or failure of Customer and Company to reach agreement on any matter requiring their mutual agreement under the terms of this Agreement, or (d) any valid order or ruling by any governmental agency or authority having jurisdiction over the subject matter of this Agreement.

- 12.8 Anything in this Agreement to the contrary notwithstanding, if any Party's liability in connection with this Agreement is limited or capped pursuant to any applicable law, statute, rule or regulation, then the other Party hereto shall be entitled to elect an identical liability limitation and/or cap as if such law, statute, rule or regulation were applicable to such Party.
- 12.9 Notwithstanding any other provision of this Agreement, this Article shall survive the termination, cancellation or expiration of this Agreement.

13.0 Employee Claims; Insurance

- 13.1 The Company elects to self-insure to maintain the insurance coverage amounts set forth in Exhibit C of this Agreement.
- 13.2 Prior to commencing Work on the Project and during the term of the Agreement, the Customer, at its own cost and expense, shall procure and maintain insurance in form and amounts set forth in Exhibit C of this Agreement, or Customer may self-insure to the extent authorized or licensed to do so under the applicable laws of the State of New York. Customer hereby elects to self-insure to maintain the insurance coverage amounts set forth in Exhibit C of this Agreement.
- 13.3 Except to the extent Customer self-insures in accordance with Section 13.2 hereof, the Customer shall have its insurer furnish to the Company certificates of insurance, on forms approved by the Insurance Commissioner of the State of New York, evidencing the insurance coverage required by this Article, such certificates to be provided prior to commencement of Work.
- 13.4 Each Party shall be separately responsible for insuring its own property and operations.

14.0 Assignment and Subcontracting

- 14.1 Either Party may assign this Agreement, or any part thereof, to any of its Affiliates provided such assignee Affiliate agrees in writing to be bound by the terms and conditions of this Agreement. Any assignment of this Agreement in violation of the foregoing shall be voidable at the option of the non-assigning Party. Each Party has the right to subcontract some or all of the work to be performed by such Party under the terms of this Agreement. Each Party may also use the services of its Affiliates in connection with its performance under this Agreement. Customer agrees that the costs and expenses of such Affiliates or contractors charged to or incurred by Company shall be paid by Customer as part of the Company Reimbursable Costs.

15.0 Independent Contractor; No Partnership; No Agency; No Utility Services

- 15.1 Company and Customer shall be independent contractors. This Agreement shall not be interpreted or construed to create an association, joint venture, agency relationship, or partnership between the Parties or to impose any partnership obligation or partnership liability upon any Party. No Party shall have any right, power or authority to enter into any agreement or undertaking for, or act on behalf of, or be an agent or representative of, or to otherwise bind, the other Party. This Agreement is not an agreement to provide or take utility services of any kind, including, without limitation, interconnection or other electric transmission services.

16.0 Examination, Inspection and Witnessing

16.1 Subject to Customer's and its representatives' compliance with Company's security, safety, escort and other access requirements, the Customer and/or its representatives shall have the right to inspect and examine the Work, or witness any test with respect to the Work, from time to time, when and as mutually agreed by the Parties, at Customer's sole cost and expense, and with reasonable prior notice to Company. Unless otherwise agreed between the Parties, such inspections, examinations and tests shall be scheduled during normal business hours.

17.0 Safety

17.1 Each Party shall be solely responsible for the safety and supervision of its own employees, representatives and contractors involved with the Work or any other activities contemplated by this Agreement. In connection with the activities contemplated by this Agreement, each Party shall, and shall require its representatives, contractors, and employees to, comply with all applicable Federal, state and local health and safety requirements, rules, regulations, laws and ordinances, including without limitation, the safety regulations adopted under the Occupational Safety and Health Act of 1970 ("OSHA"), as amended from time to time. While on the property (including, without limitation, easements or rights of way) of, or accessing the facilities of, the other Party, each Party's employees and/or contractors and agents shall at all times abide by the other Party's safety standards and policies, switching and tagging rules, and escort and other applicable access requirements. The Party owning or controlling the property or facilities shall have the authority to suspend the other Party's access, work or operations in and around such property or facilities if, in its sole judgment, at any time hazardous conditions arise or any unsafe practices are being followed by the other Party's employees, agents, representatives or contractors.

18.0 Approvals, Permits and Easements

18.1 The actual cost of obtaining all Required Approvals obtained by or on behalf of the Company shall be paid for by Customer as part of Company Reimbursable Costs.

19.0 Environmental Protection; Hazardous Substances or Conditions

19.1 The Company shall in no event be liable to Customer, its Affiliates or contractors, their respective officers, directors, employees, agents, servants, or representatives, or any third party with respect to, or in connection with, the presence of any Hazardous Substances which may be present at or on any Customer or third party owned, occupied, used, or operated property or facility (including, without limitation, easements, rights-of-way, or other third-party property) or which the Company, its Affiliates or contractors, their respective officers, directors,

employees, agents, servants, or representatives may discover, release, or generate at or on such properties or facilities through no negligent or unlawful act of the Company, and Company hereby disclaims any and all such liability to the fullest extent allowed by applicable law. Customer agrees to hold harmless, defend, and indemnify the Company, its Affiliates and contractors, and their respective directors, officers, agents, servants, employees and representatives from and against any and all claims and/or liability in connection with, relating to, or arising out of (i) the presence, discovery, release, threat of release or generation of Hazardous Substances, or (ii) the breach of any Federal, state, or local laws, rules, regulations, codes, or ordinances relating to the environment, including, without limitation, the Comprehensive Environmental Response, Compensation and Liability Act, as amended, 42 U.S.C. §§ 9601 et seq., the Resource Conservation and Recovery Act, as amended, 42 U.S.C. §§ 6901 et seq., except to the extent such presence, discovery, release, threat of release, generation or breach is or are directly and solely caused by the negligent or unlawful act of the Company or of any person or entity for whom the Company is legally responsible. The obligations under this Section shall not be limited in any way by any limitation on Customer's insurance or by any limitation of liability or disclaimer provisions contained in this Agreement. The provisions of this Section shall survive the expiration, cancellation or earlier termination of this Agreement.

- 19.2 Customer shall promptly inform the Company, in writing, of any Hazardous Substances, or unsafe, dangerous, or potentially dangerous, conditions or structures, whether above-ground or underground, that are present on, under, over, or in Customer- owned, occupied, used, managed or operated facilities or property (including, without limitation, easements, rights-of-way, or other third-party property) to be used or accessed in connection with the Work or this Agreement. Prior to Company's commencement of the Work, Customer shall be obligated to use its best efforts (including, without limitation, the use of DIGSAFE or other similar services) to adequately investigate the presence and nature of any such Hazardous Substances, or unsafe, dangerous, or potentially dangerous, conditions or structures, and to promptly, fully, and in writing, communicate the results thereof to the Company. Customer's provision to the Company of the information contemplated in this Section shall in no event give rise to any liability or obligation on the part of the Company, nor shall Customer's obligations under this Agreement, or under law, be decreased or diminished thereby.

20.0 Suspension of Work

- 20.1 Subject to Section 20.2, below, Customer may interrupt, suspend, or delay the Work by providing written notice to the Company specifying the nature and expected duration of the interruption, suspension, or delay. Company will use commercially reasonable efforts to suspend performance of the Company Work as requested by Customer. Customer shall be responsible to pay Company (as part of Company Reimbursable Costs) for all costs incurred by Company that arise as a result of such interruption, suspension or delay.
- 20.2 As a precondition to the Company resuming the Work following a suspension under Section 20.1, the Projected Milestone Schedule and the Work Cost Estimate shall be revised as mutually agreed by the Parties to reflect the interruption, suspension, or delay. Adjustments to the Company Reimbursable Costs shall include any costs or expenses the Company incurs as a result of the interruption, suspension, or delay.

21.0 Right to Terminate Agreement

- 21.1 If either Party (the “*Breaching Party*”) (a) fails to pay any amount when due under the terms of this Agreement or fails to comply with or perform, in any material respect, any of the other terms or conditions of this Agreement; (b) sells or transfers all or substantially all of its assets; (c) enters into any voluntary or involuntary bankruptcy proceeding or receivership; or (d) makes a general assignment for the benefit of its creditors, then the other Party (the “*Non-Breaching Party*”) shall have the right, without prejudice to any other right or remedy and after giving five (5) Days’ written prior notice to the Breaching Party and a reasonable opportunity for cure (not to exceed thirty (30) Days in the case of a failure to pay amounts when due), to terminate this Agreement, in whole or in part, and thereupon each Party shall discontinue its performance hereunder to the extent feasible and make every reasonable effort to procure cancellation of existing Work- and/or Project- related commitments, orders and contracts upon terms that are reasonably expected to minimize all associated costs. However, nothing herein will restrict Company’s ability to complete aspects of the Work that Company must reasonably complete in order to return its facilities and the Sites to a configuration in compliance with Good Utility Practice and all Applicable Requirements. The Non-Breaching Party shall also have the right to pursue any and all rights it may have against the Breaching Party under applicable law, subject to other applicable terms and conditions of this Agreement (including, without limitation, any applicable limitations on liability contained herein).
- 21.2 In the event of any early termination or cancellation of the Work as contemplated in this Agreement, Customer shall pay Company for:

- (i) all Company Reimbursable Costs for Work performed on or before the effective date of termination or cancellation;
- (ii) all other Company Reimbursable Costs incurred by Company in connection with the Work prior to the effective date of termination or cancellation, including, without limitation, for materials, equipment, tools, construction equipment and machinery, engineering and other items, materials, assets or services which cannot reasonably be avoided, mitigated or cancelled;
- (iii) all Company Reimbursable Costs incurred to unwind Work that was performed prior to the effective date of termination or cancellation to the extent reasonably necessary to return Company's facilities to a configuration in compliance with Good Utility Practice and all Applicable Requirements;
- (iv) all Company Reimbursable Costs arising from cancellation costs relating to orders or contracts entered into in connection with the Work prior to the effective date of termination or cancellation; and
- (v) all Company Reimbursable Costs arising from demobilization expenses incurred by Company which cannot be reasonably avoided or mitigated.

22.0 [Reserved]

23.0 Force Majeure

23.1 A "*Force Majeure Event*" shall include fire, flood, windstorm, adverse weather conditions, emergencies, explosion, terrorism, riot, war, sabotage, acts of God, strikes or labor slow-downs, court injunction or order, federal and/or state law or regulation, delays by governmental authorities in approving regulatory, license and permit requests necessary in connection with the Work or Project, or order by any federal or state regulatory agency, or other causes, conditions or circumstances beyond the affected Party's reasonable control. Without limiting the foregoing, a "Force Majeure Event" shall also include unavailability of personnel, equipment, supplies, or other resources ("*Resources*") due to diversion of such Resources for other utility-related duties in connection with an emergency or other similar contingency, including, without limitation, storms or other adverse weather conditions.

If a Force Majeure Event should occur and impair the ability of either or both Parties to perform its, or their respective, obligations hereunder, then, to the extent affected by such Force Majeure Event, the performance of this Agreement, with the exception of payment obligations, shall be suspended for the duration of such Force Majeure Event. At the conclusion of a Force Majeure Event, the price and time for performance under this Agreement shall be adjusted as reasonably necessary to overcome the effect of the delay occasioned by such Force Majeure Event. The foregoing notwithstanding and with the exception of payment

obligations, if, as the direct or indirect result of any Force Majeure Event, the Parties' continued performance hereunder becomes irreparably impaired or prevented, the Parties may mutually agree to terminate this Agreement, in whole or in part, with no further obligation or liability; provided, however, that, notwithstanding any such termination, Customer shall pay the Company all of the Company's Company Reimbursable Costs in accordance with Section 21.2 of this Agreement.

- 23.2 Within thirty (30) Days after the termination of any delay occasioned by a Force Majeure Event, the affected Party shall give written notice to the other Party specifying the estimated impact of the delay.
- 23.3 For the avoidance of doubt: to the extent any Party has a payment obligation pursuant to the terms of this Agreement, such payment obligation shall not be subject to or conditioned upon such Party receiving funding or reimbursement from any third party (and any failure to secure such funding or reimbursement shall not constitute a Force Majeure Event), nor shall any such obligation be conditioned upon the other Party executing any certificates or other instruments not expressly and specifically required by the terms of this Agreement.

24.0 [Reserved]

25.0 Proprietary and Confidential Information

- 25.1 Each Party acknowledges that, in the course of the performance of this Agreement, it may have access to Proprietary Information of the other Party.
- 25.2 General Restrictions. Upon receiving Proprietary Information, the Receiving Party) and its Representative shall keep in strict confidence and not disclose to any person (with the exception of the Representatives of the Receiving Party, to the extent each such Representative has a need to know in connection herewith) any of the Disclosing Party's Proprietary Information except as otherwise provided by the terms and conditions of this Agreement. The Receiving Party and its Representatives shall not use such Proprietary Information except for the purposes identified herein without the prior written approval of the Disclosing Party. The Receiving Party shall be solely liable for any breach of this Section to the extent caused by its Representatives. Customer agrees that any Proprietary Information will be used solely for the Project and will not be used, either directly or indirectly, for the Customer's financial gain and/or commercial advantage or in violation of any applicable laws, rules or regulations.
- 25.3 Exceptions. Subject to Section 25.4 hereof, the Receiving Party shall not be precluded from, nor liable for, disclosure or use of Proprietary Information that:
- 25.3.1 is in or enters the public domain, other than by a breach of this Section; or

- 25.3.2 is known to the Receiving Party or its Representatives at the time of first disclosure hereunder, or thereafter becomes known to the Receiving Party or its Representatives subsequent to such disclosure without similar restrictions from a source other than the Disclosing Party, as evidenced by written records; or
- 25.3.3 is developed by the Receiving Party or its Representatives independently of any disclosure under this Agreement, as evidenced by written records; or
- 25.3.4 is disclosed more than three (3) years after first receipt of the disclosed Proprietary Information, or three (3) years after the termination or expiration of this Agreement, whichever occurs later (the “*Non-Disclosure Term*”); or
- 25.3.5 is disclosed following receipt of the Disclosing Party’s written consent to the disclosure of such Proprietary Information; or
- 25.3.6 is necessary to be disclosed, in the reasonable belief of the Receiving Party or its Representatives, for public safety reasons, provided, that, Receiving Party has attempted to provide as much advance notice of the disclosure to the Disclosing Party as is practicable under the circumstances.

Anything in this Article or the Agreement to the contrary notwithstanding, the Receiving Party or its Representative(s) may disclose Proprietary Information of the other Party to the extent the Receiving Party or its Representative(s) is required to do so by law, by a court, or by other governmental or regulatory authorities; provided, however, that, if permitted to do so by applicable law, the Receiving Party shall give the Disclosing Party written notice of any such required disclosure prior to such disclosure being made so that the Disclosing Party may seek a protective order with respect to such Proprietary Information. Receiving Party will reasonably cooperate with the Disclosing Party’s efforts to obtain such protective order.

- 25.4 Each Party acknowledges that information and/or data disclosed under this Agreement may include “critical energy infrastructure information” under applicable FERC rules and policies (“*CEII*”). Receiving Party shall, and shall cause its Representatives to, strictly comply with any and all laws, rules and regulations (including, without limitation, FERC regulations, rules, orders and policies) applicable to any such CEII disclosed by or on behalf of Disclosing Party or that relates to any of Disclosing Party’s or Disclosing Party’s Affiliates’ facilities.

Neither the Receiving Party nor its Representatives shall divulge any such CEII to any person or entity, directly or indirectly, unless permitted to do so by law and unless the Receiving Party has first obtained, in each case, the express specific written consent of the Disclosing Party and any affected Affiliate of the Disclosing Party. In any event, to the extent that the Receiving Party or any of its Representatives seeks or is ordered to submit any such CEII to FERC, a state regulatory agency, court or other governmental body, the Receiving Party shall, in addition to obtaining the Disclosing Party's and its Affiliate's prior written consent (as applicable), seek a protective order or other procedural protections to ensure that such information is accorded CEII status and is otherwise treated as confidential.

In the case of any Proprietary Information that is CEII, Receiving Party's obligations and duties under this Article shall survive until (i) the expiration of the Non-Disclosure Term, or (ii) the date on which such CEII is no longer required to be kept confidential under applicable law, whichever is later. With respect to CEII, in the event of any conflict or inconsistency between this Section and any other term or provision of this Agreement, this Section shall govern in connection with such CEII.

- 25.5 Notwithstanding any provision of this Agreement to the contrary, all assets, equipment and facilities procured or constructed by or on behalf of Company, and all plans, designs, specifications, drawings and other materials and documents created or prepared by or for Company, in connection with the Work, and all title, copyright, intellectual property and other rights therein, shall be and remain the sole property of Company.
- 25.6 This Article shall survive any termination, expiration or cancellation of this Agreement.

26.0 Governing Law; Effect of Applicable Requirements

- 26.1 This Agreement is made and shall be interpreted, construed, governed, and enforced in accordance with the laws of the State of New York, without reference to such State's conflict-of-laws doctrine. The Company and Customer agree to submit to the personal jurisdiction of the courts in the State of New York, or the Federal District courts in the State of New York, as permitted by law, with respect to any matter or dispute arising out of this Agreement.
- 26.2 If and to the extent a Party is required or prevented or limited in taking any action or performance with respect to this Agreement by any Applicable Requirement(s), such Party shall not be deemed to be in breach of this Agreement as a result of such compliance with the Applicable Requirement(s).

27.0 Miscellaneous

- 27.1 **Project Managers.** Promptly following the Effective Date, each Party shall designate a Project Manager and shall provide the other Party with a written notice containing the name and contact information of such Project Manager. Whenever either Party is entitled to approve a matter, the Project Manager for the Party responsible for the matter shall notify the Project Manager of the other Party of the nature of such matter. The Project Managers shall discuss such matter, and each Project Manager shall confer on such matter on behalf of his/her Party. The foregoing notwithstanding, in no event shall any Project Manager be authorized to amend or modify the provisions of this Agreement. Each Party may change its Project Manager, from time to time, by written notice to the other Party.
- 27.2 **Dispute Resolution.** Any dispute arising under this Agreement shall be the subject of good-faith negotiations between the Parties. Each Party shall designate one or more representatives with the authority to negotiate the matter in dispute for the purpose of participating in such negotiations. Unless a Party identifies exigent circumstances reasonably requiring expedited resolution of the dispute by a court or agency with jurisdiction over the dispute, any dispute that is not resolved through good-faith negotiations after a negotiation period of not less than thirty (30) days may be submitted by either Party for resolution to a court or to an agency with jurisdiction over the dispute. Notwithstanding the foregoing, any dispute arising under this Agreement may be submitted to non-binding arbitration or any other form of alternative dispute resolution upon the agreement of both Parties to participate in such an alternative dispute resolution process.
- 27.3 **Compliance with Law.** Each Party shall comply, at all times, with all Applicable Requirements in connection with this Agreement and performance hereunder. Such compliance shall include, among other things, compliance with all applicable wage and hour laws and regulations and all other laws and regulations dealing with or relating to the employment of persons, and the payment of contributions, premiums, and taxes required by such laws and regulations. For the avoidance of doubt: neither Party shall be required to undertake or complete any action or performance under this Agreement that is inconsistent with such Party's standard safety practices, its material and equipment specifications, its design criteria and construction procedures, its labor agreements, Good Utility Practice and/or any Applicable Requirement(s).

- 27.4 **Form and Address.** All notices, invoices and other communications from either Party to the other hereunder shall be in writing and shall be deemed received (i) upon actual receipt when personally delivered, (ii) upon acknowledgment of receipt if sent by facsimile, (iii) upon the expiration of the third (3rd) business Day after being deposited in the United States mails, postage prepaid, certified or registered mail, or (iv) upon the expiration of one (1) business Day after being deposited during the regular business hours for next-day delivery and prepaid for overnight delivery with a national overnight courier, addressed to the other Party. Each Party may change its address by giving the other Party notice thereof in conformity with this Section. Any payments made under this Agreement, if made by mail, shall be deemed to have been made on the date of receipt thereof.
- 27.5 **Exercise of Right.** No failure or delay on the part of either Party in exercising any right, power, or privilege hereunder, and no course of dealing between the Parties, shall operate as a waiver thereof; nor shall any single or partial exercise of any right, power, or privilege hereunder preclude any other or further exercise thereof or the exercise of any other right, power, or privilege.
- 27.6 **Headings.** The descriptive headings of the several Articles, sections, and paragraphs of this Agreement are inserted for convenience only and do not constitute a part of this Agreement. Such headings shall not in any way define or affect the meaning, construction, or scope of any of the provisions hereof.
- 27.7 **Incorporation of Schedules and Exhibits.** The schedules, attachments and exhibits referenced in and attached to this Agreement shall be deemed an integral part hereof to the same extent as if written in whole herein. In the event that any inconsistency exists between the provisions of this Agreement and any schedules, attachments or exhibits attached hereto, the provisions of this Agreement shall supersede the provisions of any such schedules, attachments or exhibits.
- 27.8 **Prior Agreements; Modifications.** This Agreement and the schedules, attachments and exhibits attached hereto constitute the entire agreement between the Parties with respect to the subject matter hereof, and supersede all previous understandings, commitments, or representations concerning such subject matter. Each Party acknowledges that the other Party has not made any representations other than those that are expressly contained herein. This Agreement may not be amended or modified in any way, and none of its provisions may be waived, except by a writing signed by an authorized representative of the Party against whom the amendment, modification, or waiver is sought to be enforced. The Project Managers shall not be authorized representatives within the meaning of this Section.

- 27.9 **Severability.** Whenever possible, each provision of this Agreement shall be interpreted in such manner as to be effective and valid under applicable law, but if any provision hereof shall be prohibited by, or determined to be invalid under, applicable law, such provision shall be ineffective to the extent of such prohibition or invalidity, without invalidating the remainder of such provision or the remaining provisions of this Agreement.
- 27.10 **Nouns and Pronouns.** Whenever the context may require, any pronouns used in this Agreement shall include the corresponding masculine, feminine, or neuter forms, and the singular forms of nouns and pronouns shall include the plural, and vice versa.
- 27.11 **No Third Party Beneficiaries.** Nothing in this Agreement is intended to confer on any person, other than the Parties, any rights or remedies under or by reason of this Agreement.
- 27.12 **Validity; Required Regulatory Approvals.**
- (a) Each Party hereby represents that the provisions of this Agreement constitute valid and legally binding obligations of such Party and are enforceable in accordance with their terms.
- (b) Subject to Section 23.3 of this Agreement, the obligations of each Party under this Agreement are expressly contingent upon (i) each Party receiving all licenses, permits, permissions, certificates, approvals, authorizations, consents, franchises and releases from any local, state, or federal regulatory agency or other governmental agency or authority (which may include, without limitation and as applicable, the NYISO and the NYPSC) or any other third party that may be required for such Party in connection with the performance of such Party's obligations under or in connection with this Agreement (the "Required Approvals"), (ii) each Required Approval being granted without the imposition of any modification or condition of the terms of this Agreement or the subject transactions, unless such modification(s) or condition(s) are agreed to by both Parties in their respective sole discretion, and (iii) all applicable appeal periods with respect to the Required Approvals having expired without any appeal having been made or, if such an appeal has been made, a full, final and non-appealable determination having been made regarding same by a court or other administrative body of competent jurisdiction, which determination disposes of or otherwise resolves such appeal (or appeals) to the satisfaction of both Parties in their respective sole discretion.

(c) Subject to Section 23.3 of this Agreement, if any application or request is made in connection with seeking any Required Approval and is denied, or is granted in a form, or subject to conditions, that either Party rejects, in its sole discretion, as unacceptable, this Agreement shall terminate as of the date that a Party notifies the other Party of such denial or rejection, in which event the obligations of the Parties under this Agreement shall cease as of such date and this Agreement shall terminate, subject to Customer's obligation to pay Company in accordance with the terms of this Agreement (including, without limitation, Section 21.2 hereof) for all Company Reimbursable Costs. All of the Company's actual costs in connection with seeking Required Approvals shall be included within the meaning of the term Company Reimbursable Costs and shall be paid for by Customer.

27.13 **Notices** All formal notices, demands, or communications under this Agreement shall be submitted in writing either by hand, registered or certified mail, or recognized overnight mail carrier to:

To Customer: David Fingado
Manager, Capital Delivery
RG&E

To Company: Mr. William Malee
Director, Transmission Commercial
Niagara Mohawk Power Corporation
d/b/a National Grid
40 Sylvan Road
Waltham, MA 02451
(781) 907-2422

27.14 **Counterparts.** This Agreement may be executed in multiple counterparts, each of which shall be considered an original. The exchange of copies of this Agreement and of signature pages by facsimile or other electronic transmission (including, without limitation, by e-mailed PDF) shall constitute effective execution and delivery of this Agreement as to the Parties and may be used in lieu of the original Agreement for all purposes. Signatures of the Parties transmitted by facsimile or other electronic means (including, without limitation, by e-mailed PDF) shall be deemed to be their original signatures for all purposes.

[Signatures are on following page.]

IN WITNESS WHEREOF, each Party has executed this Agreement by its duly authorized representative as of the Effective Date.

ROCHESTER GAS & ELECTRIC CORPORATION

By: Mark S Lynch
Name: MARK S LYNCH
Title: PRESIDENT & CEO

NIAGARA MOHAWK POWER CORPORATION d/b/a National Grid

By: William L Malee
Name: William L Malee
Title: Director -Transmission Commercial

LIST OF EXHIBITS

Exhibit A	Scope of Work
Exhibit B	Projected Milestone Schedule
Exhibit C	Insurance Requirements
Exhibit D	Cost Breakdown

Exhibit A: Scope of Work

COMPANY shall perform the following Work under this Agreement:

1. Design, engineer, procure, construct, test and place into service the new Company-owned and/or operated facilities, and the modifications to existing Company-owned and/or operated facilities, as contemplated in the "STATION 251 & CIRCUIT 901 PROJECT DESCRIPTION" attached as Annex 1 to this Exhibit.
2. Design, engineer, procure, construct, test and place into service the new Company-owned and/or operated facilities, and the modifications to existing Company-owned and/or operated facilities, to upgrade the Mortimer Substation to allow it to handle 400 MVA Summer normal and 640 MVA long time emergency ("LTE") rating due to the re-conductoring of line 901 (line 901 is being upgraded by Customer to 2-1192.5MCM ACSR Bunting conductors.) This upgrade would include, without limitation, replacing Circuit Breaker R104, disconnect switches SW100, 102 and 106, and upgrading the bus work to a 3000 amp rating, modifying the 115kV take off structure to handle the new 2-1192.5 conductors on line 901, and replacing the bushing potential device with a CVT, all as more specifically referenced in Technical Scope Document for Substations "Mortimer – Protection and Station upgrades for line 901 re-conductoring" attached as Annex 2 to this Exhibit.
3. Perform engineering review and field verifications as required on the facilities referred to in Paragraphs 1 and 2 of this Exhibit.
4. Prepare, file for, and use commercially reasonable efforts to obtain any Required Approvals that must be obtained by Company to enable it to perform the work and any other of its obligations contemplated by this Exhibit and this Agreement.
5. Inspect, review, witness, examine and test, from time to time, Company's work contemplated herein and conduct other project management, administration and oversight activities in connection with the work contemplated by this Exhibit.
6. Review, from time to time, permitting, licensing, real property, and other materials relating to the work contemplated herein.
7. Retain and use outside experts, counsel, consultants, and contractors in furtherance of the work contemplated herein.
8. Perform any other reasonable tasks necessary or advisable in connection with the work contemplated by this Exhibit (including, without limitation, any changes thereto).

For the avoidance of doubt: the Company shall not have any responsibility for seeking or acquiring any real property rights in connection with the Work or the Project including, without limitation, licenses, consents, permissions, certificates, approvals, or authorizations, or fee, easement or right of way interests. Neither this Agreement nor the Company's Work include securing or arranging for Customer or any third party to have access rights in, through, over or under any real property owned or controlled by the Company.

NOTE: COMPANY's specifications for electrical requirements referenced for this Agreement include: ESB-750; ESB-752; ESB-755 and ESB-756, Appendix A as such may be amended, modified and superseded from time to time. See:

https://www.nationalgridus.com/niagaramohawk/construction/3_elec_specs.asp

- ~~1. Design, engineer, procure, construct, test and place into service the new Company-owned and/or operated facilities, and the modifications to existing Company-owned and/or operated facilities, as contemplated in the "STATION 251 & CIRCUIT 901-PROJECT DESCRIPTION" attached as Annex 1 to this Exhibit.~~
- ~~2. Perform engineering review and field verifications as required on the facilities described in Annex 1 to this Exhibit.~~
- ~~3. Prepare, file for, and use commercially reasonable efforts to obtain any Required Approvals that must be obtained by Company to enable it to perform the work and any other of its obligations contemplated by this Exhibit and this Agreement.~~
- ~~4. Inspect, review, witness, examine and test, from time to time, Company's work contemplated herein and conduct other project management, administration and oversight activities in connection with the work contemplated by this Exhibit.~~
- ~~5. Review, from time to time, permitting, licensing, real property, and other materials relating to the work contemplated herein.~~
- ~~6. Retain and use outside experts, counsel, consultants, and contractors in furtherance of the work contemplated herein.~~
- ~~7. Perform any other reasonable tasks necessary or advisable in connection with the work contemplated by this Exhibit (including, without limitation, any changes thereto).~~

~~For the avoidance of doubt: the Company shall not have any responsibility for seeking or acquiring any real property rights in connection with the Work or the Project including, without limitation, licenses, consents, permissions, certificates, approvals, or authorizations, or fee, easement or right of way interests. Neither this Agreement nor the Company's Work include securing or arranging for Customer or any third party to have access rights in, through, over or under any real property owned or controlled by the Company.~~

~~NOTE: COMPANY's specifications for electrical requirements referenced for this Agreement include: ESB-750; ESB-752; ESB-755 and ESB-756, Appendix A as such may be amended, modified and superseded from time to time. See:~~

~~https://www.nationalgridus.com/niagaramohawk/construction/3_elec_specs.asp~~

Annex 1 to Exhibit A

STATION 251 & CIRCUIT 901 PROJECT DESCRIPTION

[Mortimer Station-RG&E Line 901 Re-conductor protection and R104 upgrades](#)

[Project Funding Number: C056410](#)

[Work order number: 10017980563](#)

[Link to documentum:](#)

<http://docuweb3:8080/webtop/drl/objectId/0b0017c3805b73c8>

[Mortimer Line 901 Technical Scope Document 12/17 tech review meeting comments](#)

- [Added no thermal limiting component statement](#)
- [Section 1.5.6 deleted Syracuse](#)
- [Section 3.1.1 added statement that around grid analysis not substantially impacted by circuit breaker change out](#)
- [Section 4.9 added reference to replacing surge arrestors per SMP 419..01.2 by Substation Maintenance](#)
- [Section 4.4.1 changed hook stick switch SW102 gang operated](#)
- [Section 2.9.2 change structure for switch SW102 and 106 to accept gang operated switch \(make box structure\)](#)
- [Section 10.2.2 and 10.2.3 deleted](#)
- [Section 14.1.3 added switch SW 100 to list of retirements](#)
- [Section 16.12 change the date of EDC to 12/15 one-month delay also changed line item 17, 18, 19 and 21 to 12/15.](#)
- [Section 16.7 C &I section added item number 7 HMI annunciator and item number 8 Telebyte communication signal converter.](#)
- [Attachment #7 - updated to add SAM – 900 HMI](#)

PROJECT SCOPE

The project scope is to build a new 115/11.5 kV substation to supply the University of Rochester (U of R) 11.5kV distribution system. Station 251 will break into existing RG&E overhead transmission Circuit 901 and Circuit 902. Circuit 901 will go between Station 251 and Mortimer Station. The other part of Circuit 901 designated as Circuit 943, will connect Station 251 to Transformer 8 at Station 33 and continue underground to Station 23. Circuit 902 will go between Station 251 and Station 82. The other part of Circuit 902, designated as Circuit 942 will connect Station 251 to Transformers 10 and 11 at Station 33.

~~NOTE: Station 23 is a 115/11.5kV Station in downtown Rochester owned by RG&E. Presently Circuit 920 and Circuit 901 supply the 115/11.5kV transformers directly with no high side interrupting devices. Station 23 will be rebuilt by RG&E and a 115kV GIS will be established by RG&E. For the avoidance of doubt: in connection with this project, RG&E will perform all work on the portions of Circuits 901, 902, 920, 942 and 943 located outside of the property line of the National Grid stations (including, without limitation, upgrading Circuit 901 to increase the transmission capacity from 200 MVA to 400 MVA.) All work inside the property line of the National Grid stations (including, without limitation, work on the portions of Circuits 901, 902, 920, 942 and 943 located inside the property line of such stations); shall be performed by National Grid pursuant and subject to this scope of work.~~

PROJECT TECHNICAL DESCRIPTION:

Station 251:

115 kV:

- ~~• Ring bus configuration with AIS SF6 breakers and motor gang operated disconnect switches.~~
- ~~• 2 Power transformers 115/15kV, 42/56/70(78.5) MVA, with LTC. Impedance = 13.37% → 14.56% at 42 MVA for all taps.~~

11.5kV

- ~~• Metal clad switchgear arrangement with 2 11.5 kV Circuit Breakers to feed the U of R distribution.~~

P&C

- ~~• The protection and control work to be performed at Station 251 includes: install new protection and control devices for the 115 kV Circuits (901, 902, 942 and 943), 115 kV Bus 1 and 2, two Power Transformers, and two 11.5 kV feeders to U of R.~~

Communication:

- ~~• Relay communications for system protection will be via fiber. A new SONET (JMUX) system will be installed by RG&E.~~
- ~~• RG&E will install new fiber connection between Station 251 to Station 82 and from Station 82 to Mortimer Station.~~

Circuit 901:

- ~~• Circuit 901 will be completely rebuilt by RG&E from Mortimer Station to Station 251 and from Station 251 to Station 33. The bundled conductor size is yet to be determined.~~
- ~~• RG&E will provide and construct new structures to meet the new load characteristics.~~
- ~~• RG&E will install OPGW between Station 33 to 251 and from Station 251 to Mortimer Station~~

National Grid Mortimer Station:

Protection and Control

It is necessary to install a new “A” and “B” protection systems at Mortimer Station in order to match the relays at Station 251. The line protection will utilize two new microprocessor based line differential relays. The automatic reclosing and breaker failure functions will be employed within separate microprocessor based relays. RG&E and

~~National Grid will work collaboratively to reach a design that is mutually agreeable to both companies.~~

Communication

~~New GE JMUX and Fiber Distribution Panel are required at Mortimer Station in order to meet the new protection requirements and new communication scheme. In addition, to provide redundant fiber connection between Mortimer Station and Station 82 a new underground conduit for fiber connection will be necessary. [National Grid will perform installation of such new GE JMUX and Fiber Distribution Panel, and such new underground conduit, within Mortimer Station as part of this project scope.]~~

115 kV Yard Equipment and Structures

~~The existing dead end structure associated with Circuit 901 needs to be evaluated due to the new 400 MVA transmission capacity; it is expected that the dead end structure will need to be replaced. If National Grid determines that such replacement is necessary, such replacement will be performed by National Grid as part of this project scope.~~

Annex 2 to Exhibit A

Technical Scope Document for Substations
(Mortimer – Protection and Station upgrades for
line 901 re-conductoring)

nationalgrid	ENGINEERING DOCUMENT	Doc. # PR.02.00.018
	Procedure: General – Substation Design	Page 1 of 3
	Technical Scope Document for Substations	Version 4.0 – 04/18/14
Application	Mortimer – Protection and Station upgrades for line 901 re-conductoring	Version 1.0 - 12/17/14

INTRODUCTION

This procedure describes the technical scope for substations. It includes approval, summary, and technical sections.

PURPOSE

The purpose of this procedure is to define the technical scope for substations.

ACCOUNTABILITY

This procedure applies to all National Grid personnel involved with the technical scope for substations.

COORDINATION

Coordination shall occur with the project team members.

REFERENCES

Project Management Playbook

PR.02.00.012 - Preliminary Engineering Checklist

DEFINITIONS

C&I – Control and Integration

N/A – Not Applicable

SED – Substation Engineering and Design

TSD – Technical Scope Document for Substations

U/G - Underground

TRAINING

Project Management Playbook Training

SED Personnel – as needed / when revised per PR.01.00.007 – Subject Matter Experts

NOTE: Changes to this procedure may affect PR.02.00.012 – Preliminary Engineering Checklist

PRINTED COPIES ARE NOT DOCUMENT CONTROLLED. FOR THE LATEST AUTHORIZED VERSION PLEASE REFER TO THE APPROPRIATE DEPARTMENT WEBSITE OR DOCUMENTUM.		
FILE: PR.02.00.018 TECHNICAL SCOPE DOCUMENT FOR SUBSTATIONS APP FILE: MORTIMER – PROTECTION AND STATION UPGRADES FOR LINE 901 RE-CONDUCTORING	ORIGINATING DEPARTMENT: SUBSTATION ENGINEERING AND DESIGN	SPONSOR: JOHN E. GAVIN

nationalgrid	ENGINEERING DOCUMENT	Doc. # PR.02.00.018
	Procedure: General – Substation Design	Page 2 of 3
	Technical Scope Document for Substations	Version 4.0 – 04/18/14
Application	Mortimer – Protection and Station upgrades for line 901 re-conductoring	Version 1.0 - 12/17/14

REVISION HISTORY

<u>Version</u>	<u>Date</u>	<u>Description of Revision</u>
1.0	05/06/09	Initial version of document.
2.0	12/28/09	<p>Converted document to new format.</p> <p>Changed title from "Technical Requirements for Substations" to "Technical Scope Requirements for Substations"</p> <p>Changed "Technical Requirements: for" in header to "Application"</p> <p>Added Section 2.1.4</p> <p>Revised Section 2.4.1</p> <p>Revised Section 2.4.2.c</p> <p>Revised Section 2.4.3.c</p> <p>Revised Section 2.4.3.d</p> <p>Revised Section 2.4.3.g</p> <p>Revised Section 2.4.3.h</p> <p>Revised Section 2.4.3.k</p> <p>Revised Section 2.4.3.l</p> <p>Revised Section 2.4.4.c</p> <p>Revised Section 2.4.4.d</p> <p>Revised Section 2.4.4.g</p> <p>Revised Section 2.4.4.h</p> <p>Revised Section 2.4.4.k</p> <p>Revised Section 2.4.4.l</p> <p>Revised Section 2.4.5.c</p> <p>Revised Section 2.4.5.d</p> <p>Revised Section 2.4.5.g</p> <p>Revised Section 2.4.5.h</p> <p>Revised Section 2.4.5.k</p> <p>Revised Section 2.4.5.l</p> <p>Revised Section 2.4.6.c</p> <p>Revised Section 2.4.6.d</p> <p>Revised Section 2.4.6.g</p> <p>Revised Section 2.4.6.h</p> <p>Revised Section 2.4.6.k</p> <p>Revised Section 2.4.6.l</p> <p>Revised Section 2.5</p> <p>Revised Section 2.6</p> <p>Revised Section 2.7</p> <p>Revised Section 2.8</p> <p>Revised Section 2.13</p>
2.1	2/16/10	<p>Changed title from "Technical Scope Requirements for Substations" to "Technical Requirements for Substations"</p> <p>Added a check box stating "This project involves a change to the conductor size/thermal rating or equipment rating in the Transmission Facility (NE: 69 kV and above; NY: 115 kV and above)." on page 3.</p> <p>Removed Document Number, "Procedure: General – Substation Design", version and date revised of PR.02.00.018, and "Application" in header of document starting on the 4th page.</p> <p>Table of Contents relocated to after the Approvals section.</p> <p>Added Section 1.3 Safety By Design</p> <p>Added Attachment #5 – Project Schedule</p>

PRINTED COPIES ARE NOT DOCUMENT CONTROLLED. FOR THE LATEST AUTHORIZED VERSION PLEASE REFER TO THE APPROPRIATE DEPARTMENT WEBSITE OR DOCUMENTUM.		
FILE:PR.02.00.018 TECHNICAL SCOPE DOCUMENT FOR SUBSTATIONS APP FILE: MORTIMER – PROTECTION AND STATION UPGRADES FOR LINE 901 RE-CONDUCTORING	ORIGINATING DEPARTMENT: SUBSTATION ENGINEERING AND DESIGN	SPONSOR: JOHN E. GAVIN

nationalgrid	ENGINEERING DOCUMENT	Doc. # PR.02.00.018
	Procedure: General – Substation Design Technical Scope Document for Substations	Page 3 of 3 Version 4.0 – 04/18/14
Application	Mortimer – Protection and Station upgrades for line 901 re-conductoring	Version 1.0 - 12/17/14

Added "Detailed" to Attachment #7
Added Project Schedule Template

- 2.2 11/29/10 Section 2.13 – Removed "(see Section 2.13.1 for template)" in Attachment #5 and added "(refer to Section 2.13.1 for example)" to Attachment #6.
Section 2.13.1 – Revised "Project Schedule Template" to "Final Engineering Schedule Example"
- 3.0 12/10/12 Revised Title from "Technical Requirements for Substations" to "Technical Scope Document for Substations" and made appropriate revisions throughout the document.
Revised document to reflect updated process including changes to departments, approvals, order no.'s, and company no.'s.
Added Section 1.4 – Associated Work
Section 1.5 – Added "Energy Delivery" and "Identify any scope exceptions".
Section 2.2.4 – Added "and if so, indicate oil containment type."
Added Section 2.4.3 – Lightning Protection and 2.4.4 – Indoor/Outdoor Lighting.
Section 2.4.4.a – Added "transformer designation".
Section 2.5 – Removed "action".
Sections 2.5.1 and 2.5.2 – added "safety switches".
Sections 2.6, 2.7, and 2.9 – Revised to "Provide a high level scope summary here" and added the appropriate Attachment(s) and description to each section.
Section 2.10.1 – Added "cyber".
Added Section 3.0 – References.
Section 4.0 – Revised attachments.
Revised Sponsor in footer from "Donald T. Angell" to "John E. Gavin".
- 4.0 4/18/14 Cover page – updated to clarify exceptions to presentation at Engineering Review Meeting.
Approvals page – moved Protection Engineer to bottom of listing.
Section 1.3 – added "If none specific to project N/A section"
Reformatted multiple sections so that no section has more than three layers of subsections.
Categorized sections for better flow and create a simpler format that would easily align with PR.02.00.012 – Preliminary Engineering Checklist.
Added group classification numbering from PL.01.00.002 – Classification and Numbering to each category to aide in locating relevant procedures, guidelines, and standards related to the category.

PRINTED COPIES ARE NOT DOCUMENT CONTROLLED. FOR THE LATEST AUTHORIZED VERSION PLEASE REFER TO THE APPROPRIATE DEPARTMENT WEBSITE OR DOCUMENTUM		
FILE: PR.02.00.018 TECHNICAL SCOPE DOCUMENT FOR SUBSTATIONS APP FILE: MORTIMER – PROTECTION AND STATION UPGRADES FOR LINE 901 RE-CONDUCTORING	ORIGINATING DEPARTMENT: SUBSTATION ENGINEERING AND DESIGN	SPONSOR: JOHN E. GAVIN

nationalgrid	ENGINEERING DOCUMENT	Page 1 of 39
	Technical Scope Document for Substations Mortimer – Protection and Station upgrades for line 901 re-conductoring	Version 1.0 - 12/17/14

Technical Scope

for

Mortimer – Protection and Station upgrades for line 901 re-conductoring

Order No. **10017980563** Company No. **5210 - Niagara Mohawk Power Corp**

Order No. _____ Company No. _____

Prepared By: **Tom McMahon**

Version: **1.0** Date: **12/17/14**

Check the following:

- This Technical Scope Document has been presented and approved at the Engineering Review Meeting dated 12/10/14.
- This Technical Scope Document is not required to be presented at the Engineering Review Meeting because it meets at least one of the following:
 - Is a one for one asset replacement
 - Is a substation retirement
 - Is estimated to be \$250k or less
- Preliminary Engineering Checklist (PR.02.00.012) completed and available in Documentum in accordance with PR.09.01.0JB – Documentum File Structure Job Aid.
- Environmental Guidance Form completed 10/30/14 and available in Documentum in accordance with PR.09.01.0JB – Documentum File Structure Job Aid.
- This project involves a change to the conductor size / thermal rating or equipment rating in a Transmission Facility (NE: 69 kV and above; NY: 115 kV and above).

PRINTED COPIES ARE NOT DOCUMENT CONTROLLED. FOR THE LATEST AUTHORIZED VERSION PLEASE REFER TO THE APPROPRIATE DEPARTMENT WEBSITE OR DOCUMENTUM.		
FILE: PR.02.00.018 TECHNICAL SCOPE DOCUMENT FOR SUBSTATIONS APP FILE: MORTIMER – PROTECTION AND STATION UPGRADES FOR LINE 901 RE-CONDUCTORING	ORIGINATING DEPARTMENT: SUBSTATION ENGINEERING AND DESIGN	SPONSOR: JOHN E. GAVIN

nationalgrid	ENGINEERING DOCUMENT	Page 2 of 39
	Technical Scope Document for Substations Mortimer – Protection and Station upgrades for line 901 re-conductoring	Version 1.0 - 12/17/14

Roles and Responsibilities: Instructions for completion of the Technical Scope Document

- COVER PAGE**
To be completed by the Technical Lead and routed for approval.
- APPROVALS**
Technical Scope Document is to be approved by the Project Team prior to the Engineering Review Meeting. The Functional Manager(s) review the Technical Scope Document at the Engineering Review Meeting. Based on the meeting, the Technical Lead is to forward the Technical Scope Document for Engineering Management Approval.
- SECTION 1**
To be completed by the Technical Lead
- ALL OTHER SECTIONS**
To be completed by the Engineering team including the Technical Lead.

The Technical Lead will take the lead on coordination and assembly of the technical section, and of its presentation for approval by the Engineering Management Review Committee. After approval, the Technical Lead will forward it to the Project Manager for inclusion in the Project Management Plan and file a copy in the Documentum project folder in accordance with PR.09.01.0JB – Documentum File Structure Job Aid.

The Project Manager will coordinate and assemble the Project Management Plan.

NOTES:

1. The red text in the template is guidance text for development of the Technical Scope Document content. When creating a TSD, replace the guidance text with project specific detail and change the text color to black.
2. Group Classification numbers refer to the second and third group of characters that define the policies, procedures, specifications, and standards relevant to a particular piece of equipment or process. The group classifications can be found in PL.01.00.002 – Classification and Numbering. The inclusion of the group classification is to aid in researching details for the particular topic.
3. N/A Primary Electrical Scope – Voltage Levels that are not needed. Recommend placing N/A in the section header (PRIMARY ELECTRICAL SCOPE – VOLTAGE LEVEL 3 (N/A)) and delete its associated subsections.
4. Once completed with the Technical Scope Document update the table of contents, especially if sections were N/A'd.

PRINTED COPIES ARE NOT DOCUMENT CONTROLLED. FOR THE LATEST AUTHORIZED VERSION PLEASE REFER TO THE APPROPRIATE DEPARTMENT WEBSITE OR DOCUMENTUM.		
FILE: PR.02.00.018 Technical Scope Document for SUBSTATIONS APP FILE: MORTIMER – PROTECTION AND STATION UPGRADES FOR LINE 901 RE-CONDUCTORING	ORIGINATING DEPARTMENT: SUBSTATION ENGINEERING AND DESIGN	SPONSOR: JOHN E. GAVIN

nationalgrid	ENGINEERING DOCUMENT	Page 3 of 39
	Technical Scope Document for Substations Mortimer – Protection and Station upgrades for line 901 re-conductoring	Version 1.0 - 12/17/14

APPROVALS

The following are the project team member approvals. (Check each that apply.)

<input checked="" type="checkbox"/> Substation Technical Lead Approval	<u>Tom McMahon</u> Tom McMahon	<u>12/10/14</u> Date
<input checked="" type="checkbox"/> Substation Civil / Structural Engineer Approval	<u>Tim Guzzo</u> Tim Guzzo	<u>12/10/14</u> Date
<input checked="" type="checkbox"/> Control & Integration Engineer Approval	<u>James Gemmell</u> James Gemmell	<u>12/10/14</u> Date
<input checked="" type="checkbox"/> Meter Engineer Approval	<u>Nick Ritts</u> Nick Ritts	<u>12/10/14</u> Date
<input checked="" type="checkbox"/> Telecom Engineer Approval	<u>Ross Kennedy</u> Ross Kennedy	<u>12/10/14</u> Date
<input type="checkbox"/> Underground / D-Line Engineer Approval	<u>x</u> Enter name here	<u> </u> Date
<input checked="" type="checkbox"/> Substation O&M Services Engineer Approval	<u>Steve Rhoads</u> Enter name here	<u>12/10/14</u> Date
<input checked="" type="checkbox"/> Protection Engineer Approval	<u>Charlie Hitchings</u> Charlie Hitchings	<u>12/10/14</u> Date

APPROVALS (Engineering Management)

Protection Engineering Manager Approval	<u>Mark Stanbro</u> Mark D Stanbro	<u>12/18/14</u> Date
Substation Engineering Manager Approval	<u>Daniel M. Reichard</u> Dan Reichard	<u>12/18/2014</u> Date

PRINTED COPIES ARE NOT DOCUMENT CONTROLLED.		
FOR THE LATEST AUTHORIZED VERSION PLEASE REFER TO THE APPROPRIATE DEPARTMENT WEBSITE OR DOCUMENTUM.		
FILE: PR.02.00.018 TECHNICAL SCOPE DOCUMENT FOR SUBSTATIONS APP FILE: MORTIMER – PROTECTION AND STATION UPGRADES FOR LINE 901 RE-CONDUCTORING	ORIGINATING DEPARTMENT: SUBSTATION ENGINEERING AND DESIGN	SPONSOR: JOHN E. GAVIN

nationalgrid	ENGINEERING DOCUMENT	Page 4 of 39
	Technical Scope Document for Substations Mortimer – Protection and Station upgrades for line 901 re-conductoring	Version 1.0 - 12/17/14

DOCUMENT CONTENTS

Table of Contents

1.0	SUMMARY.....	7
1.1	INTRODUCTION.....	7
1.2	SITE SAFETY.....	7
1.3	SAFETY BY DESIGN (GROUP CLASSIFICATION 02.00).....	7
1.4	ASSOCIATED WORK (GROUP CLASSIFICATION 02.00).....	8
1.5	ENGINEERING & DESIGN DELIVERY.....	8
1.6	ASSUMPTIONS, EXCEPTIONS, AND RISKS.....	9
2.0	CIVIL / STRUCTURAL SCOPE.....	9
2.1	SITE WORK (GROUP CLASSIFICATION 03.01).....	9
2.2	FENCING (GROUP CLASSIFICATION 03.05).....	9
2.3	FLOOD RISK (ST.02.00.004).....	9
2.4	FOUNDATIONS (GROUP CLASSIFICATION 03.03).....	9
2.5	WALLS (GROUP CLASSIFICATION 03.03).....	9
2.6	CABLE TRENCH (GROUP CLASSIFICATION 04.15).....	9
2.7	OIL CONTAINMENT (GROUP CLASSIFICATION 03.01).....	10
2.8	"SPCC" PLAN (PL.01.00.004 & 006).....	10
2.9	STRUCTURES (GROUP CLASSIFICATION 03.02).....	10
2.10	PRE-ENGINEERED (SITE BUILT) BUILDINGS (GROUP CLASSIFICATION 03.04).....	10
2.11	FACILITY FABRICATED CONTROL / EQUIPMENT ENCLOSURES (GROUP CLASSIFICATION 03.04).....	10
2.12	ENVIRONMENTAL.....	10
3.0	PRIMARY ELECTRICAL SCOPE – GENERAL.....	10
3.1	GROUND GRID (GROUP CLASSIFICATION 04.12).....	10
3.2	LIGHTNING PROTECTION (GROUP CLASSIFICATION 04.14).....	11
3.3	U/G DUCT BANKS (GROUP CLASSIFICATION 04.15).....	11
3.4	CONDUITS (GROUP CLASSIFICATION 04.15).....	11
3.5	INDOOR / OUTDOOR LIGHTING (GROUP CLASSIFICATION 04.11).....	11
3.6	LOW VOLTAGE (600V) POWER AND CONTROL CABLES (GROUP CLASSIFICATION 05.08).....	11
3.7	FIBER OPTIC CABLES (GROUP CLASSIFICATION 05.05).....	12
4.0	PRIMARY ELECTRICAL SCOPE – VOLTAGE LEVEL 1 (115KV).....	12
4.1	POWER TRANSFORMER (GROUP CLASSIFICATION 04.02).....	12
4.2	METAL-CLAD SWITCHGEAR (GROUP CLASSIFICATION 04.05).....	12
4.3	CIRCUIT INTERRUPTER (GROUP CLASSIFICATION 04.01).....	12
4.4	DISCONNECT SWITCHES (GROUP CLASSIFICATION 04.09).....	12
4.5	CAPACITOR BANKS (GROUP CLASSIFICATION 04.08).....	12
4.6	REACTOR (GROUP CLASSIFICATION 04.13).....	12
4.7	INSTRUMENT TRANSFORMER (GROUP CLASSIFICATION 04.03).....	13
4.8	LINE TRAPS / TUNERS (GROUP CLASSIFICATION 04.07).....	13

PRINTED COPIES ARE NOT DOCUMENT CONTROLLED. FOR THE LATEST AUTHORIZED VERSION PLEASE REFER TO THE APPROPRIATE DEPARTMENT WEBSITE OR DOCUMENTUM.		
FILE:PR.02.00.018 TECHNICAL SCOPE DOCUMENT FOR SUBSTATIONS APP FILE: MORTIMER – PROTECTION AND STATION UPGRADES FOR LINE 901 RE-CONDUCTORING	ORIGINATING DEPARTMENT: SUBSTATION ENGINEERING AND DESIGN	SPONSOR: JOHN E. GAVIN

nationalgrid	ENGINEERING DOCUMENT	Page 5 of 39
	Technical Scope Document for Substations Mortimer – Protection and Station upgrades for line 901 re-conductoring	Version 1.0 - 12/17/14

4.9	SURGE ARRESTERS (GROUP CLASSIFICATION 04.19)	13
4.10	VOLTAGE REGULATORS (GROUP CLASSIFICATION 04.04).....	13
4.11	PRIMARY BUS WORK (GROUP CLASSIFICATION 04.17).....	13
4.12	HIGH VOLTAGE U/G POWER CABLE (>1000VOLTS)	13
5.0	PRIMARY ELECTRICAL SCOPE – VOLTAGE LEVEL 2 (N/A)	13
5.1	POWER TRANSFORMER (GROUP CLASSIFICATION 04.02)	13
5.2	METAL-CLAD SWITCHGEAR (GROUP CLASSIFICATION 04.05)	13
5.3	CIRCUIT INTERRUPTER (GROUP CLASSIFICATION 04.01)	13
5.4	DISCONNECT SWITCHES (GROUP CLASSIFICATION 04.09).....	13
5.5	CAPACITOR BANKS (GROUP CLASSIFICATION 04.08).....	13
5.6	REACTOR (GROUP CLASSIFICATION 04.13).....	13
5.7	INSTRUMENT TRANSFORMER (GROUP CLASSIFICATION 04.03)	13
5.8	LINE TRAPS / TUNERS (GROUP CLASSIFICATION 04.07)	14
5.9	SURGE ARRESTERS (GROUP CLASSIFICATION 04.19)	14
5.10	VOLTAGE REGULATORS (GROUP CLASSIFICATION 04.04).....	14
5.11	PRIMARY BUS WORK (GROUP CLASSIFICATION 04.17).....	14
5.12	HIGH VOLTAGE U/G POWER CABLE (>1000VOLTS)	14
6.0	STATION SERVICE SCOPE	14
6.1	DC POWER (GROUP CLASSIFICATION 05.06)	14
6.2	AC POWER (GROUP CLASSIFICATION 05.07)	14
6.3	STANDBY GENERATOR (GROUP CLASSIFICATION 05.07)	14
7.0	PROTECTION SCOPE	14
7.1	PROTECTION DETAILS (GROUP CLASSIFICATION 10.00, 10.01, & 10.02)	14
8.0	CONTROL AND INTEGRATION SCOPE	15
8.1	CONTROL AND INTEGRATION DETAILS (GROUP CLASSIFICATION 05.01, 05.03, & 05.10)	15
9.0	REVENUE METERING SCOPE	16
9.1	REVENUE METERING DETAILS (GROUP CLASSIFICATION 05.09)	16
10.0	COMMUNICATIONS SCOPE	17
10.1	COMMUNICATIONS DETAILS (GROUP CLASSIFICATION 05.05).....	17
10.2	CIRCUIT REQUIREMENTS:	18
10.3	ATTACHMENT #8 LIST ADDITIONS, CHANGES OR MODIFICATIONS TO THE COMMUNICATIONS SYSTEM.	18
11.0	MISCELLANEOUS SCOPE	18
11.1	SITE SECURITY (GROUP CLASSIFICATION 02.04 & 03.04)	18
11.2	ANIMAL INTRUSION PROTECTION (GROUP CLASSIFICATION 04.18)	18
11.3	FIRE ALARM / FIRE PROTECTION (ST.02.00.004).....	18
11.4	INSULATORS AND SURGE ARRESTERS	18
11.5	STEEL STRUCTURE PAINTING	18
12.0	TEMPORARY FACILITIES / MOBILE TRANSFORMER SCOPE	18

PRINTED COPIES ARE NOT DOCUMENT CONTROLLED. FOR THE LATEST AUTHORIZED VERSION PLEASE REFER TO THE APPROPRIATE DEPARTMENT WEBSITE OR DOCUMENTUM		
FILE:PR.02.00.018 TECHNICAL SCOPE DOCUMENT FOR SUBSTATIONS APP FILE: MORTIMER – PROTECTION AND STATION UPGRADES FOR LINE 901 RE-CONDUCTORING	ORIGINATING DEPARTMENT: SUBSTATION ENGINEERING AND DESIGN	SPONSOR: JOHN E. GAVIN

nationalgrid	ENGINEERING DOCUMENT	Page 6 of 39
	Technical Scope Document for Substations Mortimer – Protection and Station upgrades for line 901 re-conductoring	Version 1.0 - 12/17/14

12.1	TEMPORARY FACILITIES	18
12.2	MOBILE TRANSFORMER.....	18
13.0	SPARE PARTS	19
13.1	SPARE PARTS DETAILS	19
14.0	REMOVALS AND RETIREMENTS SCOPE	19
14.1	REMOVALS AND RETIREMENTS DETAILS.....	19
15.0	REFERENCES.....	19
16.0	LIST OF ATTACHMENTS.....	20
16.1	ATTACHMENT #1: EXISTING ONE LINE / OPERATING DIAGRAM	21
16.2	ATTACHMENT #2: PROPOSED ONE LINE / OPERATING DIAGRAM	22
16.3	ATTACHMENT #3: PRELIMINARY PROTECTION SINGLE LINES SHEET 1	23
16.4	ATTACHMENT #4: PRELIMINARY PROTECTION SINGLE LINES SHEET 2	24
16.5	ATTACHMENT #5: PHOTOGRAPHS	25
16.6	ATTACHMENT #6: PRELIMINARY PROTECTION RELAY LIST	27
16.7	ATTACHMENT #7-1: PRELIMINARY C&I EQUIPMENT LIST	29
16.8	ATTACHMENT #7-2: C&I POINT ASSIGNMENT (RTU1)	31
16.9	ATTACHMENT #7-3: C&I POINT ASSIGNMENT (RTU2)	32
16.10	ATTACHMENT #7-4 : C&I LAYOUT DIAGRAMS	34
16.11	ATTACHMENT #8: PRELIMINARY TELECOM EQUIPMENT LIST	37
16.12	ATTACHMENT #9: PRELIMINARY FINAL ENGINEERING AND DESIGN SCHEDULE	38
17.0	REVISION HISTORY OF PROJECT DOCUMENT	39

PRINTED COPIES ARE NOT DOCUMENT CONTROLLED. FOR THE LATEST AUTHORIZED VERSION PLEASE REFER TO THE APPROPRIATE DEPARTMENT WEBSITE OR DOCUMENTUM		
FILE: PR.02.00.018 TECHNICAL SCOPE DOCUMENT FOR SUBSTATIONS APP FILE: MORTIMER – PROTECTION AND STATION UPGRADES FOR LINE 901 RE-CONDUCTORING	ORIGINATING DEPARTMENT: SUBSTATION ENGINEERING AND DESIGN	SPONSOR: JOHN E. GAVIN

nationalgrid	ENGINEERING DOCUMENT	Page 7 of 39
	Technical Scope Document for Substations	
	Mortimer – Protection and Station upgrades for line 901 re-conductoring	Version 1.0 - 12/17/14

1.0 SUMMARY

1.1 Introduction

The scope for this project is broken up into two (2) phases. Phase 1 is to upgrade the Line 901 protection, controls and communication at National Grid's Mortimer Substation. Line 901 is currently a three-terminal 115 kV line encompassing RG&E Station 23, RG&E Station 33 and National Grid Mortimer. The 115 kV line currently connects to the 115 kV Bus at Mortimer via Circuit Breaker R104. The Line 901 segment between RG&E Station 33 and Mortimer will be looped into the new RG&E Station 251, via separate breaker-and-a-half positions, thus, creating a new two-terminal segment between new Station 251 and Mortimer. Relay upgrades at Mortimer are required to make the protection compatible with the Line 901 protection to be installed at the new RG&E Station 251 remote terminal.

Phase 2 of the project is to upgrade the Mortimer Substation to be able to handle 400 MVA summer normal and 640 MVA long time emergency (LTE) due to the re-conductoring of line 901. Line 901 is being upgraded by RG&E to 2-1192.5MCM ACSR Bunting conductor. The scope at Mortimer Substation for phase 2 includes replacing Circuit Breaker R104, disconnect switches SW102 and 106, and bus work to a 3000 amp rating. Also the 115kV take off structure will be modified to handle the new 2-1192.5 conductor on line 901. In addition the bushing potential device will be replaced with a CVT.

This project corrects transmission thermal limiting components. So once these modifications are installed there will be no thermal limiting components at this station in support of the current RG&E proposed modifications.

Mortimer Substation is located in the Western Division, part of the Genesee Region at 1430 Brighton-Herietta Townline Road Brighton, NY.

The relevant report references are listed below:

1. RG&E SPR-1256 Station 23 new 115kV source – Revision 1 (12/2/13)
2. Mortimer Substation site meeting notes (6/23/14)

1.2 Site Safety

Standard safety procedures will be observed. During the installation of this station project, work will be performed near energized 115 kV and 13.2kV buses. Personnel need to be aware of this condition and exercise caution by establishing work area protection, performing job briefings, and wearing the appropriate personal protective equipment. All National Grid employees/ contractor(s) working on this project need to follow all company and OSHA safety rules, they should also refer to the "Employee Safety Hand book".

1.3 Safety by Design (Group Classification 02.00)

PRINTED COPIES ARE NOT DOCUMENT CONTROLLED.		
FOR THE LATEST AUTHORIZED VERSION PLEASE REFER TO THE APPROPRIATE DEPARTMENT WEBSITE OR DOCUMENTUM.		
FILE:PR.02.00.018 TECHNICAL SCOPE DOCUMENT FOR SUBSTATIONS APP FILE: MORTIMER – PROTECTION AND STATION UPGRADES FOR LINE 901 RE-CONDUCTORING	ORIGINATING DEPARTMENT: SUBSTATION ENGINEERING AND DESIGN	SPONSOR: JOHN E. GAVIN

nationalgrid	ENGINEERING DOCUMENT	Page 8 of 39
	Technical Scope Document for Substations	
	Mortimer – Protection and Station upgrades for line 901 re-conductoring	Version 1.0 - 12/17/14

- 1.3.1 There are a significant number of underground facilities in the yard. Every effort has been made to locate all underground conduits, duct banks, etc. and ensure that the design provides for the indication and avoidance of the underground facilities where possible, to preclude an unsafe condition when digging for this project.
- 1.3.2 The existing Substation ground grid was analyzed. Additional grounding will be added to the area where the new circuit breakers are being installed. The existing ground grid will be upgraded as shown in grounding plan as part of this project.
- 1.4 Associated Work (Group Classification 02.00)
 - 1.4.1 The associated transmission line work by RG&E to re-conductor line 901.
 - 1.4.2 The associated station work to install protection, controls and communication equipment at RG&E Station 82.
 - 1.4.3 The associated work to install a new substation RG&E Station 251.
- 1.5 Engineering & Design Delivery
 - 1.5.1 Project Management will provide overall project management.
 - 1.5.2 Substation Engineering and Design New York will manage final engineering and design.
 - 1.5.3 Protection Engineering New York will provide all relay settings and perform all associated supporting calculations.
 - 1.5.4 Substation west will provide testing and commissioning services on all substation equipment, unless specified otherwise (i.e. to be performed by the manufacturer or manufacturer's representative).
 - 1.5.5 Substation Work Methods will oversee and direct the testing of power equipment.
 - 1.5.6 Protection and Telecom Operations will install relay settings, perform relay testing and will provide control and protection system testing per SMP 400.80.2 – Substation Commissioning and Energization.
 - 1.5.7 Equipment and material will be procured by National Grid.
 - 1.5.8 External contractor will be providing construction services.
 - 1.5.9 National Grid Standard Construction Specification for Electric Stations, SP.08.00.001, shall be utilized for all construction details.
 - 1.5.10 A mobile substation will not be required during the outage in order to maintain distribution loads associated with this substation. It is anticipated that work will be done in a manner to allow for three of the four transformers to be energized at all times.

PRINTED COPIES ARE NOT DOCUMENT CONTROLLED. FOR THE LATEST AUTHORIZED VERSION PLEASE REFER TO THE APPROPRIATE DEPARTMENT WEBSITE OR DOCUMENTUM.		
FILE:PR.02.00.018 TECHNICAL SCOPE DOCUMENT FOR SUBSTATIONS APP FILE: MORTIMER – PROTECTION AND STATION UPGRADES FOR LINE 901 RE-CONDUCTORING	ORIGINATING DEPARTMENT: SUBSTATION ENGINEERING AND DESIGN	SPONSOR: JOHN E. GAVIN

nationalgrid	ENGINEERING DOCUMENT	Page 9 of 39
	Technical Scope Document for Substations	
	Mortimer – Protection and Station upgrades for line 901 re-conductoring	Version 1.0 - 12/17/14

1.6 Assumptions, Exceptions, and Risks

- 1.6.1 External contractor will be providing construction services.
- 1.6.2 National Grid Standard Construction Specification for Electric Stations, SP.08.00.001, shall be utilized for all construction details.
- 1.6.3 The geotechnical and soil resistivity reports were completed prior to submission of this Technical Scope Document.
- 1.6.4 The transmission thermal ratings will be changed by this modification and transmission planning will have to make the proper notifications to the NYISO as per TGP26 and OP-16 procedures.

2.0 CIVIL / STRUCTURAL SCOPE

2.1 Site Work (Group Classification 03.01)

- 2.1.1 The work will be confined to the existing station fenced yard and right of way. No station expansion to the existing station fenced yard / right of way are required.
- 2.1.2 Oil containment will be not be required for the new circuit breaker.

2.2 Fencing (Group Classification 03.05)

- 2.2.1 N/A

2.3 Flood Risk (ST.02.00.004)

- 2.3.1 The station is located in Zone X, referencing panel FM36055C0332G. Zone X is an area that has been determined to be outside the 0.2% annual chance floodplain, and therefore outside the 500 year floodplain. Therefore, no flood mitigation will be required.

2.4 Foundations (Group Classification 03.03)

- 2.4.1 Re-use foundations for the equipment listed below:
 - a. The existing foundation at R104 is to be re-used and/or repaired due to cracking.
 - b. Reuse the existing foundation for the existing steel take-off structure.
 - c. A new foundation for the 115kV CVT stand.

2.5 Walls (Group Classification 03.03)

- 2.5.1 N/A

2.6 Cable Trench (Group Classification 04.15)

PRINTED COPIES ARE NOT DOCUMENT CONTROLLED. FOR THE LATEST AUTHORIZED VERSION PLEASE REFER TO THE APPROPRIATE DEPARTMENT WEBSITE OR DOCUMENTUM.		
FILE: PR.02.00.018 TECHNICAL SCOPE DOCUMENT FOR SUBSTATIONS APP FILE: MORTIMER – PROTECTION AND STATION UPGRADES FOR LINE 901 RE-CONDUCTORING	ORIGINATING DEPARTMENT: SUBSTATION ENGINEERING AND DESIGN	SPONSOR: JOHN E. GAVIN

nationalgrid	ENGINEERING DOCUMENT	Page 10 of 39
	Technical Scope Document for Substations	
	Mortimer – Protection and Station upgrades for line 901 re-conductoring	Version 1.0 - 12/17/14

2.6.1 N/A.

2.7 Oil Containment (Group Classification 03.01)

2.7.1 Additional oil containment is not required for this site.

2.8 "SPCC" Plan (PL.01.00.004 & 006)

2.8.1 According to the SPCC plan there have been no historical releases subject to SPCC reporting requirements at this substation. Requirements for SPCC regulated facilities are identified in the Code of Federal Regulations (CFR), in Title 40, Part 112.

2.8.2 The existing SPCC plan will be revised to remove the applicable R104 oil volume.

2.9 Structures (Group Classification 03.02)

2.9.1 Mortimer disconnect switches are all mounted on the existing steel structures. The switch mounting structures will be evaluated for the added size and weight. New mounting plates will be designed for the 3000 amp switches. The proper clearances will be analyzed as part of final design.

2.9.2 Switch structures for SW102 and 106 will be modified to accept gang operated disconnects.

2.9.3 The existing structural supports will be evaluated for the new loading of the new 2- 1192.5 Conductors.

2.10 Pre-engineered (site built) Buildings (Group Classification 03.04)

2.10.1 N/A

2.11 Factory Fabricated Control / Equipment Enclosures (Group Classification 03.04)

2.11.1 N/A

2.12 Environmental

2.12.1 According to the NYSDEC Environmental Resource Map there are no State wetlands, rare plants, or rare animals in the immediate area of the station.

3.0 PRIMARY ELECTRICAL SCOPE – GENERAL

3.1 Ground Grid (Group Classification 04.12)

3.1.1 As a result of changing out the circuit breaker the ground grid analysis will not be substantially impacted. The ground grid will be modified if necessary based on the final design review of the station grounding.

3.1.2 New disconnect switches, and circuit breaker will be grounded according to the National Grid Standard ST.04.12.003 Substation Grounding.

PRINTED COPIES ARE NOT DOCUMENT CONTROLLED. FOR THE LATEST AUTHORIZED VERSION PLEASE REFER TO THE APPROPRIATE DEPARTMENT WEBSITE OR DOCUMENTUM.		
FILE:PR.02.00.018 TECHNICAL SCOPE DOCUMENT FOR SUBSTATIONS APP FILE: MORTIMER – PROTECTION AND STATION UPGRADES FOR LINE 901 RE-CONDUCTORING	ORIGINATING DEPARTMENT: SUBSTATION ENGINEERING AND DESIGN	SPONSOR: JOHN E. GAVIN

nationalgrid	ENGINEERING DOCUMENT	Page 11 of 39
	Technical Scope Document for Substations	
	Mortimer – Protection and Station upgrades for line 901 re-conductoring	Version 1.0 - 12/17/14

- 3.1.3 All the cable terminations and cable grounding will be done according to the National Grid Standard ST.04.12.003.
- 3.2 Lightning Protection (Group Classification 04.14)
 - 3.2.1 The existing lightning protection coverage is adequate because the station footprint has not changed.
- 3.3 U/G Duct Banks (Group Classification 04.15)
 - 3.3.1 N/A
- 3.4 Conduits (Group Classification 04.15)
 - 3.4.1 Two (2) new 4" conduits will be run from Station 82 to Mortimer for the new fiber optic communications cable. One will be spare.
 - 3.4.2 New 4" conduits for control and power cables will be installed from the circuit breaker to the control house.
 - 3.4.3 A new 2" conduit will be run from the CVT to the control house
 - 3.4.4 Conduit size and length will be re-confirmed during final engineering.
 - 3.4.5 Protection package A and B will be run in separate conduits in order to comply with NPCC bulk power directory 4 requirements.
 - 3.4.6 CT cable, power cable and control cable shall not be routed in the same conduit.
- 3.5 Indoor / Outdoor Lighting (Group Classification 04.11)
 - 3.5.1 N/A
- 3.6 Low Voltage (600V) Power and Control Cables (Group Classification 05.08)
 - 3.6.1 New control cables will be installed between the new 115kV equipment and the control house.
 - 3.6.2 National Grid requires that all cables, cable sizes and cable types comply with standard ST.05.08.001 – Low Voltage Power, Control and Instrumentation Cable.
 - 3.6.3 The following circuits are not to be intermixed in the same cable:
 - 3.6.4 DC and control circuits including alarms (125VDC), #12 minimum
 - 3.6.5 CT circuits (5A), #10 minimum
 - 3.6.6 Communication circuits (Telephone, Carrier, and Fiber optics) as required
 - 3.6.7 Low Voltage AC station service and lighting circuits (less than 600VAC, 20 amps continuous, 75A momentary) as required.
 - 3.6.8 High Voltage Power (greater than 600VAC and/or above 20A continuous, 75A momentary) as required.

PRINTED COPIES ARE NOT DOCUMENT CONTROLLED.		
FOR THE LATEST AUTHORIZED VERSION PLEASE REFER TO THE APPROPRIATE DEPARTMENT WEBSITE OR DOCUMENTUM.		
FILE: PR.02.00.018 TECHNICAL SCOPE DOCUMENT FOR SUBSTATIONS APP FILE: MORTIMER – PROTECTION AND STATION UPGRADES FOR LINE 901 RE-CONDUCTORING	ORIGINATING DEPARTMENT: SUBSTATION ENGINEERING AND DESIGN	SPONSOR: JOHN E. GAVIN

nationalgrid	ENGINEERING DOCUMENT	Page 12 of 39
	Technical Scope Document for Substations	
	Mortimer – Protection and Station upgrades for line 901 re-conductoring	Version 1.0 - 12/17/14

3.6.9 Control cable quantity will be determined during final engineering.

3.7 Fiber Optic Cables (Group Classification 05.05)

3.7.1 Install new fiber optic cable from Station 82 to Mortimer Station for communications equipment. Use AFL Telecom cable specification DNA-30327 or equivalent.

3.7.2 Use 1/1/4" diameter orange inner duct in the conduit or trench and control house for the fiber installation to prevent damage to the fiber optic cable.

3.7.3 Terminate fiber optic cable in patch and splice panels with bulkhead connectors.

4.0 PRIMARY ELECTRICAL SCOPE – VOLTAGE LEVEL 1 (115KV)

4.1 Power Transformer (Group Classification 04.02)

4.1.1 N/A

4.2 Metal-Clad Switchgear (Group Classification 04.05)

4.2.1 N/A

4.3 Circuit Interrupter (Group Classification 04.01)

4.3.1 Replace GE type "FK" Oil Circuit Breaker R104 with a 115kV 3000A 63kA SF6 Breaker per specification SP.04.01.002 46kV-345kV Power Circuit Breakers (SF6). The circuit breaker will have dual trip coils in order to comply with NPCC bulk power directory 4 requirements. However Mortimer does not have two battery sources and we will not meet all the bulk power requirements. The station was not designed to meet bulk power requirements.

4.3.2 See section 9 for Revenue Metering CT requirements.

4.4 Disconnect Switches (Group Classification 04.09)

4.4.1 Replace disconnect switches SW102 and 106 with 123kV 3000 amp group operated air break, vertical break switch per specification SP.04.09.001 Group operated outdoor air break disconnect switch.

4.4.2 Replace gang disconnect switch SW100 with a 123kV 2000 amp group operated air break, vertical break switch per specification SP.04.09.001 Group operated outdoor air break disconnect switch.

4.4.3

4.5 Capacitor Banks (Group Classification 04.08)

4.5.1 N/A

4.6 Reactor (Group Classification 04.13)

4.6.1 N/A

PRINTED COPIES ARE NOT DOCUMENT CONTROLLED. FOR THE LATEST AUTHORIZED VERSION PLEASE REFER TO THE APPROPRIATE DEPARTMENT WEBSITE OR DOCUMENTUM.		
FILE:PR.02.00.018 TECHNICAL SCOPE DOCUMENT FOR SUBSTATIONS APP FILE: MORTIMER – PROTECTION AND STATION UPGRADES FOR LINE 901 RE-CONDUCTORING	ORIGINATING DEPARTMENT: SUBSTATION ENGINEERING AND DESIGN	SPONSOR: JOHN E. GAVIN

nationalgrid	ENGINEERING DOCUMENT	Page 13 of 39
	Technical Scope Document for Substations Mortimer – Protection and Station upgrades for line 901 re-conductoring	Version 1.0 - 12/17/14

- 4.7 Instrument Transformer (Group Classification 04.03)
 - 4.7.1 Replace existing bushing potential device with single phase 115kV CVT with 2 secondary windings with ratios of 1000/600:1.
- 4.8 Line Traps / Tuners (Group Classification 04.07)
 - 4.8.1 N/A
- 4.9 Surge Arresters (Group Classification 04.19)
 - 4.9.1 The surge arresstor will be evaluated by Station Maintenance for possible replacement per SMP 419.01.2.
- 4.10 Voltage Regulators (Group Classification 04.04)
 - 4.10.1 N/A
- 4.11 Primary Bus Work (Group Classification 04.17)
 - 4.11.1 Replace the existing 3.5" IPS AL bus with a 5" ISP AL bus to meet 400MVA load for summer normal and 640MVA for LTE.
 - 4.11.2 Replace existing strain bus 500 CU 37 STR with 2- 1250 CU 37 STR conductor.
- 4.12 High Voltage U/G Power Cable (>1000Volts)
 - 4.12.1 N/A

5.0 PRIMARY ELECTRICAL SCOPE – VOLTAGE LEVEL 2 (N/A)

- 5.1 Power Transformer (Group Classification 04.02)
 - 5.1.1 N/A
- 5.2 Metal-Clad Switchgear (Group Classification 04.05)
 - 5.2.1 N/A
- 5.3 Circuit Interrupter (Group Classification 04.01)
 - 5.3.1 N/A
- 5.4 Disconnect Switches (Group Classification 04.09)
 - 5.4.1 N/A
- 5.5 Capacitor Banks (Group Classification 04.08)
 - 5.5.1 N/A
- 5.6 Reactor (Group Classification 04.13)
 - 5.6.1 N/A
- 5.7 Instrument Transformer (Group Classification 04.03)

PRINTED COPIES ARE NOT DOCUMENT CONTROLLED. FOR THE LATEST AUTHORIZED VERSION PLEASE REFER TO THE APPROPRIATE DEPARTMENT WEBSITE OR DOCUMENTUM.		
FILE: PR.02.00.018 TECHNICAL SCOPE DOCUMENT FOR SUBSTATIONS APP FILE: MORTIMER – PROTECTION AND STATION UPGRADES FOR LINE 901 RE-CONDUCTORING	ORIGINATING DEPARTMENT: SUBSTATION ENGINEERING AND DESIGN	SPONSOR: JOHN E. GAVIN

nationalgrid	ENGINEERING DOCUMENT	Page 14 of 39
	Technical Scope Document for Substations Mortimer – Protection and Station upgrades for line 901 re-conductoring	Version 1.0 - 12/17/14

- 5.7.1 N/A
- 5.8 Line Traps / Tuners (Group Classification 04.07)
 - 5.8.1 N/A
- 5.9 Surge Arresters (Group Classification 04.19)
 - 5.9.1 N/A
- 5.10 Voltage Regulators (Group Classification 04.04)
 - 5.10.1 N/A
- 5.11 Primary Bus Work (Group Classification 04.17)
 - 5.11.1 N/A
- 5.12 High Voltage U/G Power Cable (>1000Volts)
 - 5.12.1 N/A

6.0 STATION SERVICE SCOPE

- 6.1 DC Power (Group Classification 05.06)
 - 6.1.1 The existing 250VDC station service will be used for tripping and closing control power of the new 115kV circuit breaker. Two separate breakers will be utilized for the two trip coils. The existing DC service is adequate to handle the load.
- 6.2 AC Power (Group Classification 05.07)
 - 6.2.1 The existing 120/240VAC station service will be used for breaker compartment power, SF6 tank heaters and cabinet lighting. The existing AC service is adequate for the additional heater load.
- 6.3 Standby Generator (Group Classification 05.07)
 - 6.3.1 N/A

7.0 PROTECTION SCOPE

- 7.1 Protection Details (Group Classification 10.00, 10.01, & 10.02)
 - 7.1.1 115KV LINE 901 PROTECTION:

This line protection was designed to work in conjunction with the line protection on the remote end at RG&E's new station 251 as defined in RG&E's proposal scope document.

The "A" protection will be provided by a Schweitzer 411L line differential relay with back up step distance protection. It will communicate with station 251 via an existing fiber optic cable between the two stations. The 411L will interface

PRINTED COPIES ARE NOT DOCUMENT CONTROLLED. FOR THE LATEST AUTHORIZED VERSION PLEASE REFER TO THE APPROPRIATE DEPARTMENT WEBSITE OR DOCUMENTUM.		
FILE: PR.02.00.018 TECHNICAL SCOPE DOCUMENT FOR SUBSTATIONS APP FILE: MORTIMER – PROTECTION AND STATION UPGRADES FOR LINE 901 RE-CONDUCTORING	ORIGINATING DEPARTMENT: SUBSTATION ENGINEERING AND DESIGN	SPONSOR: JOHN E. GAVIN

nationalgrid	ENGINEERING DOCUMENT	Page 15 of 39
	Technical Scope Document for Substations	
	Mortimer – Protection and Station upgrades for line 901 re-conductoring	Version 1.0 - 12/17/14

with this fiber through G.E. JMUX communications equipment. Direct Transfer Trip (DTT) transmit and receive will be utilized in this relay for Breaker Back Up (BBU). A failed center breaker in station 251's breaker and half configuration will send DTT to Mortimer breaker R104. A failure of R104 at Mortimer for a bus section No. 1 fault or a line 901 fault will send DTT to station 251. In addition to the 411L a Schweitzer 351-6 overcurrent relay will be used as an auxiliary tripping relay to trip R104 and drive the auto reclosing to lockout when DTT is received from station 251.

The "B" protection will be provided by a G.E. L90 line differential relay with back up step distance protection. It will communicate with station 251 via a new diverse direct fiber optic cable to be installed between the two stations. This protection package, like the "A", will provide BBU and DTT. A Schweitzer 351-6 relay will be used for DTT receive tripping. Both the primary and the secondary line differential and DTT schemes will be supervised "43" ON-OFF control switches.

Auto reclosing of breaker R104 will be accomplished with a Schweitzer 351-6 overcurrent relay. It will be programmed to mimic the existing electromechanical scheme and will operate on live-bus/dead-line or synch check. It will also be incorporated into the existing bus protection "Stall" scheme and will be driven to lock out for a failure of breaker R104 and DTT receive. The existing breaker R104 is equipped with a bushing potential device on the line side that is used for auto reclosing and synch check. R104 is being replaced, therefore a new single phase 69KV -115V CVT will be installed in place of the bushing potential device and brought to the new reclosing relay.

8.0 CONTROL AND INTEGRATION SCOPE

8.1 Control and Integration Details (Group Classification 05.01, 05.03, & 05.10)

8.1.1 Energy Management System

- a. Control and Trip / Close status monitoring of R104 will be maintained on RTU1. Reclosing control and status monitoring for R104 will be added to RTU1. Analog telemetry will continue to be monitored through RTU2. All new relaying alarms and status points will be added to RTU2.
- b. A new SEL-2032 communications processor will be added to facilitate both status monitoring for the new relays as well as fault record retrieval. This device will be connected via Ethernet back to the existing Garretcom DX900 gateway device to allow remote access through the Crossbow system. This new SEL-2032 will connect to the RTU via DNP3 by connecting to the existing RS485 network associated with the existing SEL-

PRINTED COPIES ARE NOT DOCUMENT CONTROLLED.		
FOR THE LATEST AUTHORIZED VERSION PLEASE REFER TO THE APPROPRIATE DEPARTMENT WEBSITE OR DOCUMENTUM		
FILE:PR.02.00.018 TECHNICAL SCOPE DOCUMENT FOR SUBSTATIONS APP FILE: MORTIMER – PROTECTION AND STATION UPGRADES FOR LINE 901 RE-CONDUCTORING	ORIGINATING DEPARTMENT: SUBSTATION ENGINEERING AND DESIGN	SPONSOR: JOHN E. GAVIN

nationalgrid	ENGINEERING DOCUMENT	Page 16 of 39
	Technical Scope Document for Substations	
	Mortimer – Protection and Station upgrades for line 901 re-conductoring	Version 1.0 - 12/17/14

2020 devices. A coaxial connection between the SEL-2032 and the Arbiter GPS clock is also required.

- c. A new ASE SAM-900 HMI will be installed to perform local annunciation. The old annunciator will be removed from panel 3F. All alarms that are repeated to the RTU from this old annunciator will now be run directly to the RTU. A pair of new Telebyte RS232 to RS485 converters will be installed to facilitate traffic between the new HMI and the RTU. Power for the converter located within the SAM cabinet will be provided by the SAM 12V power supply.
- d. The new JMUX trouble alarms will be ganged together and connected to RTU2.
- e. All RS-485 networks shall be terminated at both ends with 120Ω resistors to eliminate reflections on the line.
- f. The RTU Points List tables in the Attachments Section contain the EMS points that will be required on both RTU1 and RTU2 at Mortimer Station.
- g. The overall connection scheme for the RTU and IEDs is shown in the Mortimer Station RTU Visio Diagram in Attachments Section.

8.1.2 Panel Metering

- a. The existing Bitronics panel meter for R104 will remain as is, returning analog quantities to RTU2. Additional analog monitoring will be maintained through the existing Ion revenue meter.

8.1.3 Control Switchboard

- a. An RE-01 dual trip coil control switch will be provided for the new circuit breaker. This control switches will be installed in the relay panel for R104 and will provide local and remote status and control functionality for trip (open)/close.
- b. An RE-43A/M switch will be provided for the new R104 circuit breaker. This switches will be installed in the relay panel for the breaker and will provide local and remote status and control functionality for Reclose auto / manual within the breaker. A site visit will be used to determine exact placement for the larger RE-43A/M switches during final design.
- c. All test switch designations and model configurations listed in the Control & Integration Material List may require modification during Final Engineering and Design to best accommodate the switchboard panel and equipment layout of the final station design.

9.0 REVENUE METERING SCOPE

9.1 Revenue Metering Details (Group Classification 05.09)

- 9.1.1 New circuit breaker CT's must be of revenue grade or +/-0.3% accuracy.

PRINTED COPIES ARE NOT DOCUMENT CONTROLLED. FOR THE LATEST AUTHORIZED VERSION PLEASE REFER TO THE APPROPRIATE DEPARTMENT WEBSITE OR DOCUMENTUM.		
FILE:PR.02.00.018 TECHNICAL SCOPE DOCUMENT FOR SUBSTATIONS APP FILE: MORTIMER – PROTECTION AND STATION UPGRADES FOR LINE 901 RE-CONDUCTORING	ORIGINATING DEPARTMENT: SUBSTATION ENGINEERING AND DESIGN	SPONSOR: JOHN E. GAVIN

nationalgrid	ENGINEERING DOCUMENT	Page 17 of 39
	Technical Scope Document for Substations	
	Mortimer – Protection and Station upgrades for line 901 re-conductoring	Version 1.0 - 12/17/14

- 9.1.2 Revenue metering CTs must be recognized by the NYS Department of Public Service - Approved Meter List 6/30/14.

10.0 COMMUNICATIONS SCOPE

10.1 Communications Details (Group Classification 05.05)

- 10.1.1 General: The Telecom related work to be performed at Mortimer includes the following:
1. Install a new 72 strand fiber optic cable between Mortimer and RG&E Station 82
 2. Install a new 72 strand fiber optic cable between Mortimer and RG&E Station 251
 3. Install a new equipment cabinet to house JMUX equipment for communications to support protection circuit
- 10.1.2 Conduits: The following to be provided:
1. Two (2) 4" schedule 80 conduits to the substation fence will be needed to provide a pathway for the 72 strand fiber optic cable between Mortimer and RG&E Station 82. RG&E will be responsible for placing and terminating the fiber optic cable. One spare for future use.
 2. One (1) 4" schedule 80 conduit from control house to Breaker R104 bay line 901 termination structure to circular AFL splice can for the 72 strand fiber optic cable between Mortimer and Station 251 via Line 901 OPGW. RG&E will be responsible for placing and terminating the fiber optic cable.
- 10.1.3 Fiber Optic: Two (2) fiber optic patch panels in Mortimer Control House, provided by RG&E, will be provided for the termination of the (2) 72 strand fiber optic cables, one for Station 82 and one for Station 251. The fiber optic cables will be terminated by RG&E.
- 10.1.4 Power: The following electrical circuits are to be provided
1. Two (2) 130VDC circuit is needed to the RG&E Equipment
 2. One (1) 120VAC circuit is needed to the RG&E Equipment

PRINTED COPIES ARE NOT DOCUMENT CONTROLLED. FOR THE LATEST AUTHORIZED VERSION PLEASE REFER TO THE APPROPRIATE DEPARTMENT WEBSITE OR DOCUMENTUM.		
FILE:PR.02.00.018 TECHNICAL SCOPE DOCUMENT FOR SUBSTATIONS APP FILE: MORTIMER – PROTECTION AND STATION UPGRADES FOR LINE 901 RE-CONDUCTORING	ORIGINATING DEPARTMENT: SUBSTATION ENGINEERING AND DESIGN	SPONSOR: JOHN E. GAVIN

nationalgrid	ENGINEERING DOCUMENT	Page 18 of 39
	Technical Scope Document for Substations	
	Mortimer – Protection and Station upgrades for line 901 re-conductoring	Version 1.0 - 12/17/14

10.1.5 Add one JMUX OC-48 shelf, provided by RG&E, mounted in the RG&E equipment cabinet. The JMUX will connect to the new 72 strand fiber optic cable and become part of the RG&E SONET Ring

10.2 Circuit Requirements:

10.2.1 Protection:

- a. Relay communications for the primary Line 901 protection current differential and DTT schemes will be through the JMUX
- b. Relay comms for the Line 901 secondary Line 901 protection current differential and DTT schemes will be direct fiber optic interconnections to the RG&E fiber optic patch panel

10.2.2 Security: None

10.3 Attachment #8 list additions, changes or modifications to the Communications system.

11.0 MISCELLANEOUS SCOPE

11.1 Site Security (Group Classification 02.04 & 03.04)

11.1.1 N/A

11.2 Animal Intrusion Protection (Group Classification 04.18)

11.2.1 N/A

11.3 Fire Alarm / Fire Protection (ST.02.00.004)

11.3.1 N/A

11.4 Insulators and Surge Arresters

11.4.1 During line 901 outage the old brown insulators should be replaced and upgraded to the new standard under the direction of the O&M Engineer.

11.5 Steel Structure painting

11.5.1 N/A

12.0 TEMPORARY FACILITIES / MOBILE TRANSFORMER SCOPE

12.1 Temporary Facilities

12.1.1 N/A

12.2 Mobile Transformer

PRINTED COPIES ARE NOT DOCUMENT CONTROLLED. FOR THE LATEST AUTHORIZED VERSION PLEASE REFER TO THE APPROPRIATE DEPARTMENT WEBSITE OR DOCUMENTUM.		
FILE:PR.02.00.018 TECHNICAL SCOPE DOCUMENT FOR SUBSTATIONS APP FILE: MORTIMER – PROTECTION AND STATION UPGRADES FOR LINE 901 RE-CONDUCTORING	ORIGINATING DEPARTMENT: SUBSTATION ENGINEERING AND DESIGN	SPONSOR: JOHN E. GAVIN

nationalgrid	ENGINEERING DOCUMENT	Page 19 of 39
	Technical Scope Document for Substations Mortimer – Protection and Station upgrades for line 901 re-conductoring	Version 1.0 - 12/17/14

12.2.1 N/A

13.0 SPARE PARTS

13.1 Spare Parts Details

13.1.1 Substation O&M Services project team member will identify and order all required spare parts.

14.0 REMOVALS AND RETIREMENTS SCOPE

14.1 Removals and Retirements Details

- 14.1.1 Existing R104 oil circuit breaker will be removed and will be send to investment recovery.
- 14.1.2 Two (2) existing hook stick disconnects 102 and 106 and the associated steel structures will be removed and sent to investment recovery.
- 14.1.3 One (1) gang operated switch SW100 will be removed and sent to investment recovery
- 14.1.4 The existing bus work 3.5" AL IPS bus tube and copper strain bus will be removed and sent to investment recovery.

15.0 REFERENCES

Document Number	Sheet	Revision	Document Title
C22305W	2	32	Single Line Diagram
C10435W	1	20	Conduit Plan
C31690W	1,2	3	R104 GE OCB type FK
D61887W	2	7	EMS point assignments
C22206W	1	7	Interconnection diagram R104 OCB
C22474W	10	14	Panel 12F line 901 R104
C22274W	2B	6	Elementary wiring diagram Line 901 OCB R104
C16753W	1	14	Electric assembly plan
STAD-Mortimer	1,2	2	Operating Diagram
SPR-1256	-	1	RG&E Station 23 new 115kV source from Mortimer technical requirements

Note: This is a compilation of documents used to develop the Technical Scope ONLY. It is not an all inclusive list of references or list of drawings affected for Step 2B: Final Engineering and Design.

PRINTED COPIES ARE NOT DOCUMENT CONTROLLED. FOR THE LATEST AUTHORIZED VERSION PLEASE REFER TO THE APPROPRIATE DEPARTMENT WEBSITE OR DOCUMENTUM.		
FILE: PR.02.00.018 TECHNICAL SCOPE DOCUMENT FOR SUBSTATIONS APP FILE: MORTIMER – PROTECTION AND STATION UPGRADES FOR LINE 901 RE-CONDUCTORING	ORIGINATING DEPARTMENT: SUBSTATION ENGINEERING AND DESIGN	SPONSOR: JOHN E. GAVIN

nationalgrid	ENGINEERING DOCUMENT	Page 20 of 39
	Technical Scope Document for Substations	
	Mortimer – Protection and Station upgrades for line 901 re-conductoring	Version 1.0 - 12/17/14

16.0 LIST OF ATTACHMENTS

- Attachment #1: Existing operating diagram
- Attachment #2: Proposed one-line diagram reflecting the project additions / removals
- Attachment #3: Preliminary Protection Single Lines sheet 1
- Attachment #4: Preliminary Protection Single Lines sheet 2
- Attachment #5: Photographs
- Attachment #6: Preliminary Protection Relay List
- Attachment #7: Preliminary C&I Equipment List
- Attachment #8: Preliminary Telecom Equipment List
- Attachment #9: Final Engineering and Design Milestone Schedule

PRINTED COPIES ARE NOT DOCUMENT CONTROLLED. FOR THE LATEST AUTHORIZED VERSION PLEASE REFER TO THE APPROPRIATE DEPARTMENT WEBSITE OR DOCUMENTUM.		
FILE:PR.02.00.018 TECHNICAL SCOPE DOCUMENT FOR SUBSTATIONS APP FILE: MORTIMER – PROTECTION AND STATION UPGRADES FOR LINE 901 RE-CONDUCTORING	ORIGINATING DEPARTMENT: SUBSTATION ENGINEERING AND DESIGN	SPONSOR: JOHN E. GAVIN

nationalgrid	ENGINEERING DOCUMENT	Page 21 of 39
	Technical Scope Document for Substations Mortimer – Protection and Station upgrades for line 901 re-conductoring	Version 1.0 - 12/17/14

16.1 Attachment #1: Existing One Line / Operating Diagram

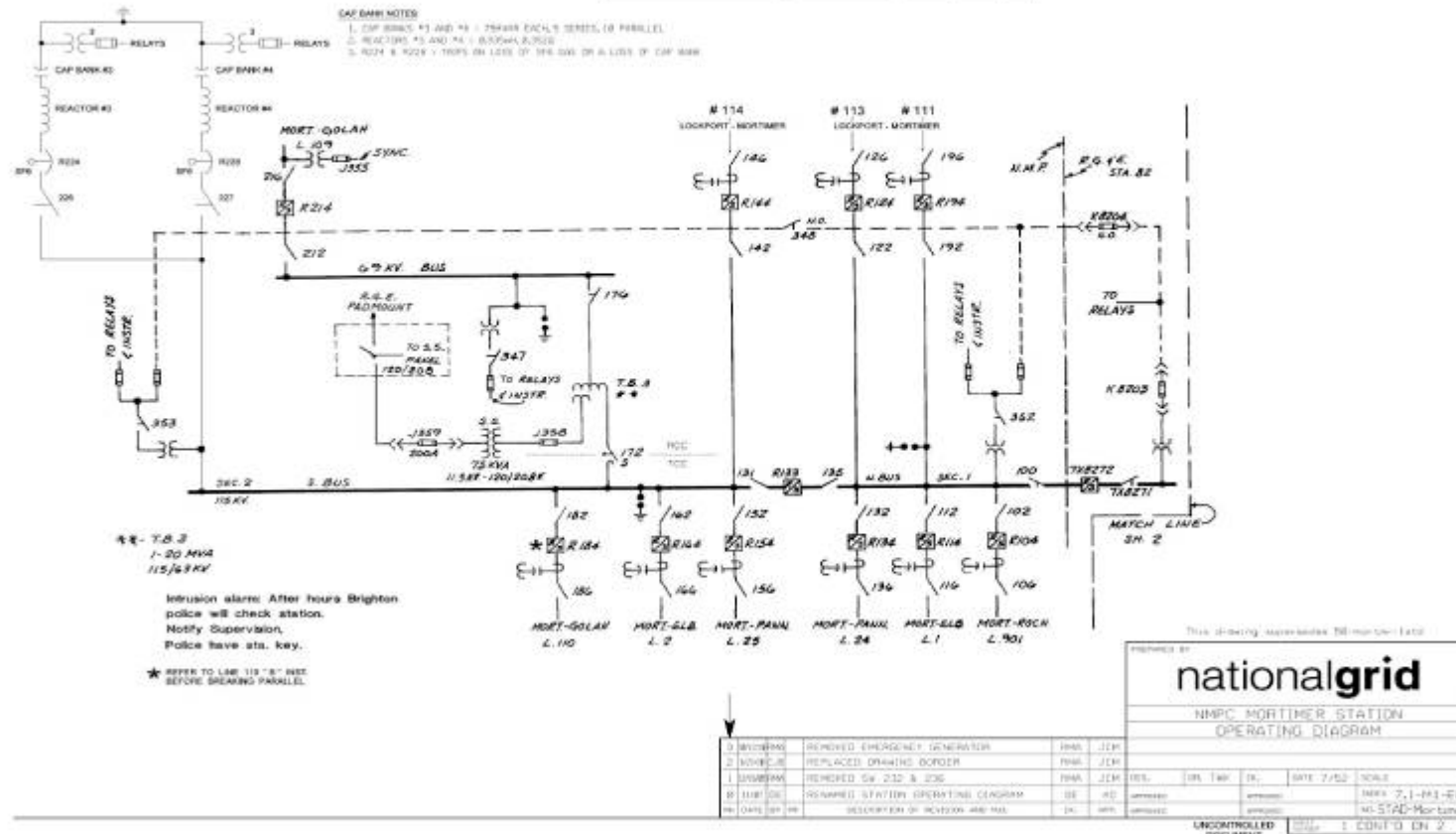

PRINTED COPIES ARE NOT DOCUMENT CONTROLLED.
 FOR THE LATEST AUTHORIZED VERSION PLEASE REFER TO THE APPROPRIATE DEPARTMENT WEBSITE OR DOCUMENTUM.

FILE PR 02 00 018 TECHNICAL SCOPE DOCUMENT FOR SUBSTATIONS	ORGANIZATION DEPARTMENT: SUBSTATION ENGINEERING AND DESIGN	SPONSOR: JOHN E. GAVIN
APP FILE: MORTIMER - PROTECTION AND STATION UPGRADES FOR LINE 901 RE-CONDUCTORING		

nationalgrid	ENGINEERING DOCUMENT	Page 22 of 39
	Technical Scope Document for Substations Mortimer – Protection and Station upgrades for line 901 re-conductoring	Version 1.0 - 12/17/14

16.2 Attachment #2: Proposed One Line / Operating Diagram

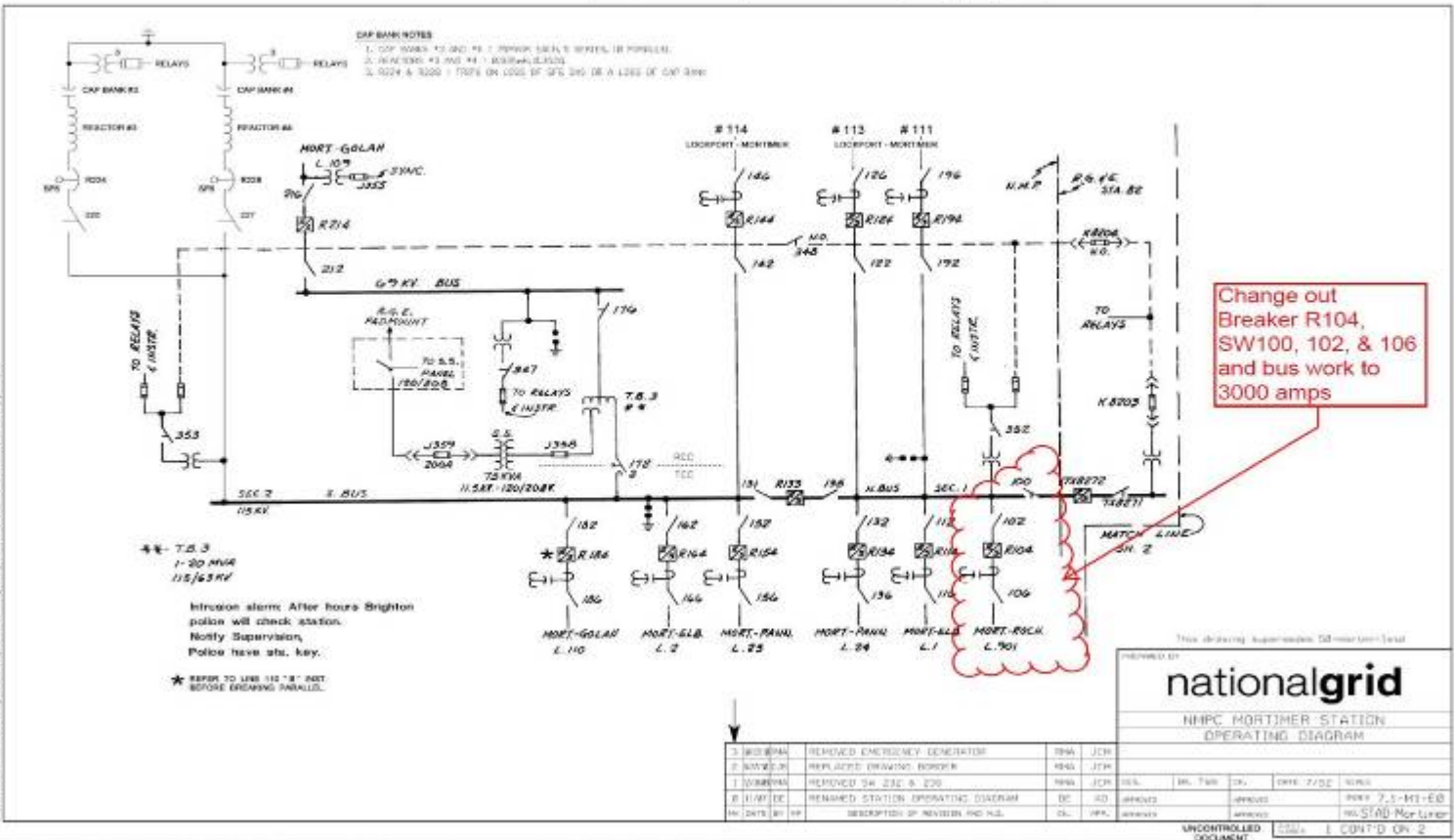

PRINTED COPIES ARE NOT DOCUMENT CONTROLLED.
 FOR THE LATEST AUTHORIZED VERSION PLEASE REFER TO THE APPROPRIATE DEPARTMENT WEBSITE OR DOCUMENTUM.

FILE PR 02 00 01 B TECHNICAL SCOPE DOCUMENT FOR SUBSTATIONS	ORIGINATING DEPARTMENT: SUBSTATION ENGINEERING AND DESIGN	SPONSOR: JOHN E. GAVIN
APP FILE: MORTIMER – PROTECTION AND STATION UPGRADES FOR LINE 901 RE-CONDUCTORING		

nationalgrid	ENGINEERING DOCUMENT	Page 23 of 39
	Technical Scope Document for Substations Mortimer – Protection and Station upgrades for line 901 re-conductoring	Version 1.0 - 12/17/14

16.3 **Attachment #3: Preliminary Protection Single Lines sheet 1**

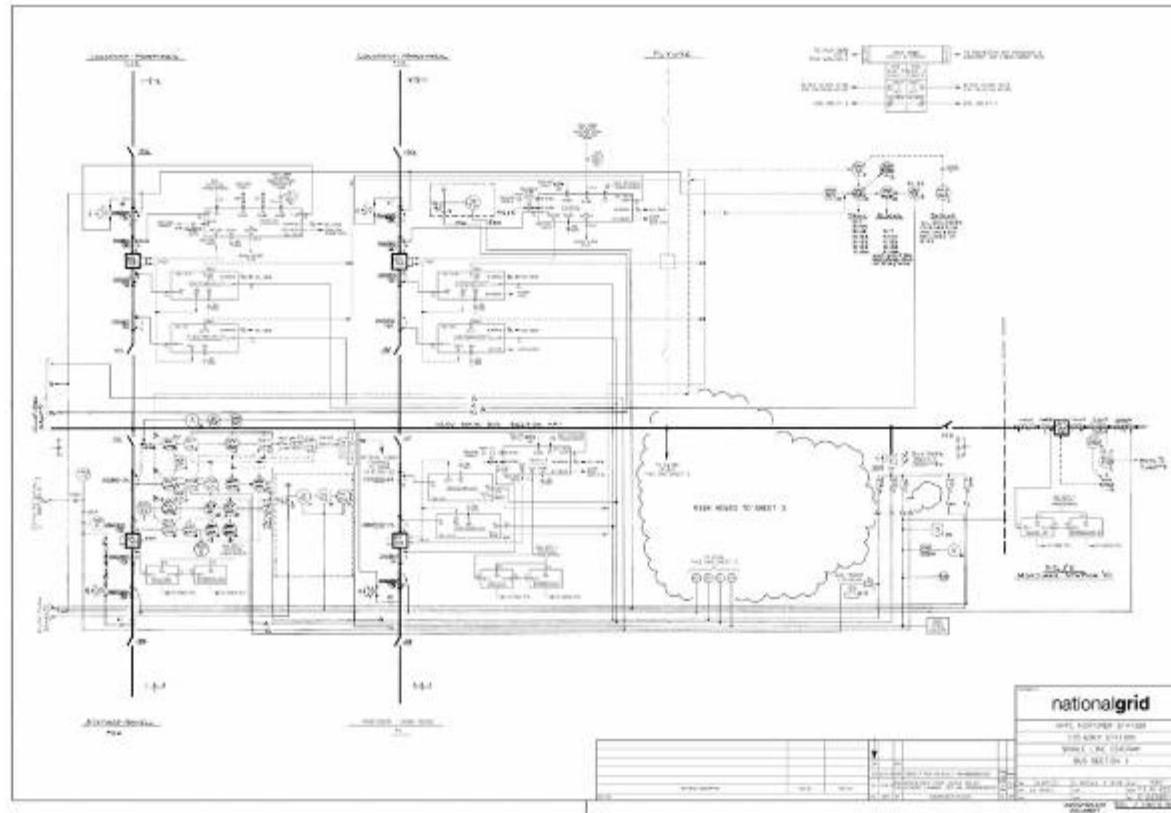

PRINTED COPIES ARE NOT DOCUMENT CONTROLLED. FOR THE LATEST AUTHORIZED VERSION PLEASE REFER TO THE APPROPRIATE DEPARTMENT WEBSITE OR DOCUMENTUM.		
FILE PR.02.00.018 TECHNICAL SCOPE DOCUMENT FOR SUBSTATIONS	ORGANIZATION DEPARTMENT: SUBSTATION ENGINEERING AND DESIGN	SPONSOR: JOHN E. GAVIN
APP FILE: MORTIMER – PROTECTION AND STATION UPGRADES FOR LINE 901 RE-CONDUCTORING		

nationalgrid	ENGINEERING DOCUMENT	Page 24 of 39
	Technical Scope Document for Substations Mortimer – Protection and Station upgrades for line 901 re-conductoring	Version 1.0 - 12/17/14

16.4 **Attachment #4: Preliminary Protection Single Lines sheet 2**

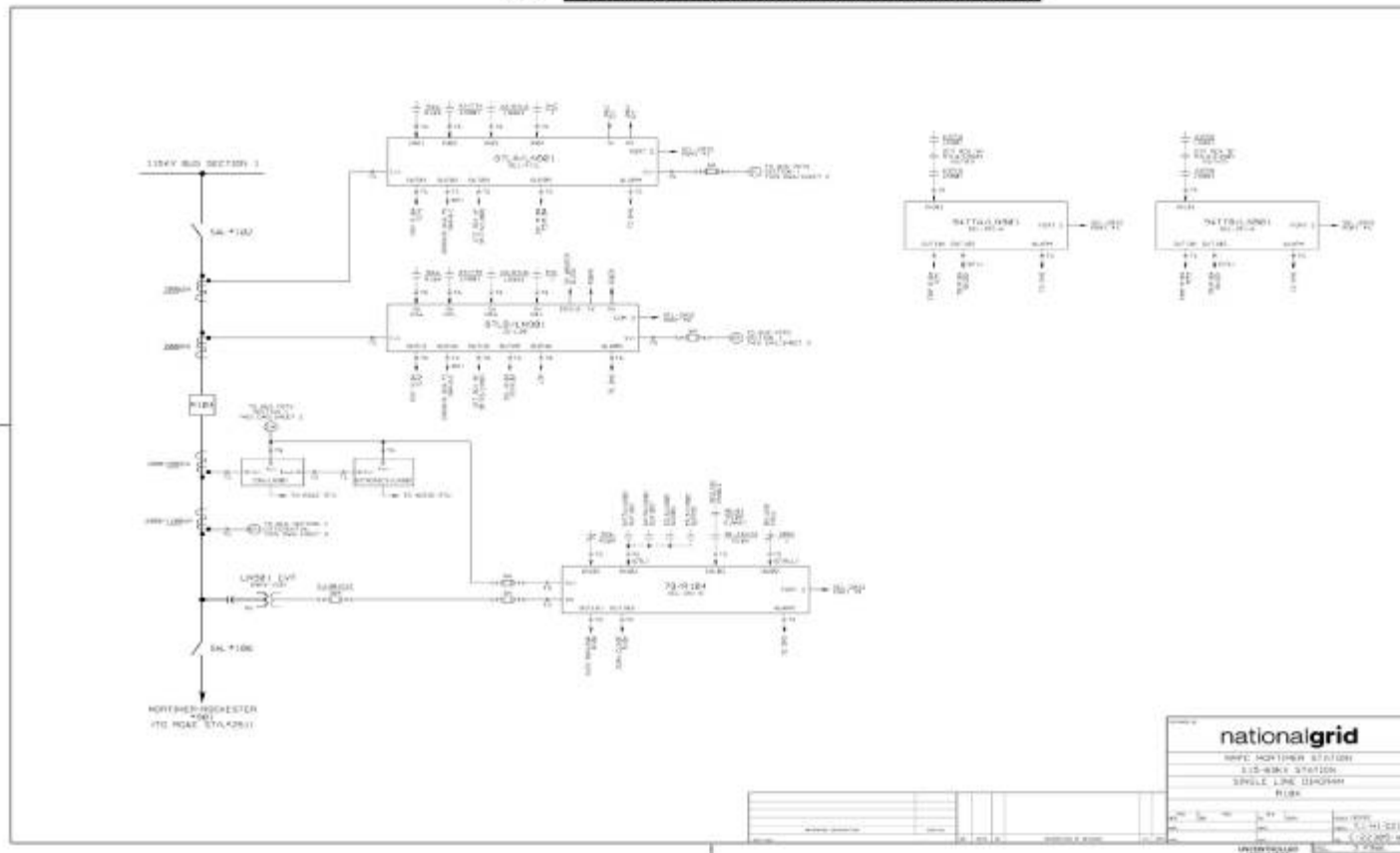

PRINTED COPIES ARE NOT DOCUMENT CONTROLLED. FOR THE LATEST AUTHORIZED VERSION PLEASE REFER TO THE APPROPRIATE DEPARTMENT WEBSITE OR DOCUMENTUM.		
FILE PR.02.00.018 TECHNICAL SCOPE DOCUMENT FOR SUBSTATIONS APP FILE: MORTIMER – PROTECTION AND STATION UPGRADES FOR LINE 901 RE-CONDUCTORING	ORIGINATING DEPARTMENT: SUBSTATION ENGINEERING AND DESIGN	SPONSOR: JOHN E. GAVIN

nationalgrid	ENGINEERING DOCUMENT	Page 25 of 39
	Technical Scope Document for Substations Mortimer – Protection and Station upgrades for line 901 re-conductoring	Version 1.0 - 12/17/14

16.5 **Attachment #5: Photographs**



PRINTED COPIES ARE NOT DOCUMENT CONTROLLED. FOR THE LATEST AUTHORIZED VERSION PLEASE REFER TO THE APPROPRIATE DEPARTMENT WEBSITE OR DOCUMENTUM.		
FILE: PR.02.00.018 TECHNICAL SCOPE DOCUMENT FOR SUBSTATIONS APP FILE: MORTIMER – PROTECTION AND STATION UPGRADES FOR LINE 901 RE-CONDUCTORING	ORIGINATING DEPARTMENT: SUBSTATION ENGINEERING AND DESIGN	SPONSOR: JOHN E. GAVIN

nationalgrid	ENGINEERING DOCUMENT	Page 26 of 39
	Technical Scope Document for Substations Mortimer – Protection and Station upgrades for line 901 re-conductoring	Version 1.0 - 12/17/14



Pic1 Breaker



Pic 2 disconnect switches 102 and 106

PRINTED COPIES ARE NOT DOCUMENT CONTROLLED. FOR THE LATEST AUTHORIZED VERSION PLEASE REFER TO THE APPROPRIATE DEPARTMENT WEBSITE OR DOCUMENTUM.		
FILE: PR.02.00.018 TECHNICAL SCOPE DOCUMENT FOR SUBSTATIONS APP FILE: MORTIMER – PROTECTION AND STATION UPGRADES FOR LINE 901 RE-CONDUCTORING	ORIGINATING DEPARTMENT: SUBSTATION ENGINEERING AND DESIGN	SPONSOR: JOHN E. GAVIN

nationalgrid	ENGINEERING DOCUMENT	Page 27 of 39
	Technical Scope Document for Substations	
	Mortimer – Protection and Station upgrades for line 901 re-conductoring	Version 1.0 - 12/17/14

16.6 **Attachment #6: Preliminary Protection Relay List**

<u>Item</u>	<u>ANSI/IEEE Device Designation</u>	<u>Quantity</u>	<u>Description Comments</u>
Mortimer Line 901 PROTECTION			
1	87LA/LN901	1	Schweitzer: SEL-411L Line Differential Relay Part No: 0411L1X6X5C6C0XH5E676XX Key Code: 8302 5U Horizontal Rack Mount 125/250 VDC Power Supply 250 VDC Control Voltage Additional I/O Board 850nm multi mode IEEE C37.94 Fiber Interface
2	87LB/LN901	1	G.E. L90 Line Differential Relay Part No: N00-HKH-F8L-H6U-L6U-NXX-SXX-UXX-W7K Horizontal Rack Mount 125/250 VDC Power Supply 1300nm single mode, LASER, 2 Channel Fiber Interface NOTE: This Relay MUST be ordered with the same Software Number as RG&E's relay or they will not work together!
3	94TTA/LN901 94TTB/LN901 79/R104	3	Schweitzer: SEL-351-6 Overcurrent Relay Part No: 035163C4E562X1 Key Code: 6141 3U Horizontal Rack Mount 125/250 VDC Power Supply 250 VDC Control Voltage Additional I/O Board
4	43TTA/LN901 43TTB/LN901	2	G.E. ON-OFF Switch, Type SBM Part No: 16SBMF2A08S1A3V1 6-Stage, 2 Position Fixed Oval Handle Nameplate Engraving: OFF – ON Escutcheon to read "TRANSFER TRIP"
5	43/87LA/LN901 43/87LB/LN901	2	G.E. ON-OFF Switch, Type SBM Part No: 16SBMF2A08S1A3V1 6-Stage, 2 Position Fixed Oval Handle Nameplate Engraving: OFF – ON Escutcheon to read "LINE DIFF"

PRINTED COPIES ARE NOT DOCUMENT CONTROLLED. FOR THE LATEST AUTHORIZED VERSION PLEASE REFER TO THE APPROPRIATE DEPARTMENT WEBSITE OR DOCUMENTUM.		
FILE: PR.02.00.018 TECHNICAL SCOPE DOCUMENT FOR SUBSTATIONS APP FILE: MORTIMER – PROTECTION AND STATION UPGRADES FOR LINE 901 RE-CONDUCTORING	ORIGINATING DEPARTMENT: SUBSTATION ENGINEERING AND DESIGN	SPONSOR: JOHN E. GAVIN

nationalgrid	ENGINEERING DOCUMENT	Page 28 of 39
	Technical Scope Document for Substations	
	Mortimer – Protection and Station upgrades for line 901 re-conductoring	Version 1.0 - 12/17/14

Note: The above relay model numbers are subject to change to reflect current National Grid Standards in Step 2B: Final Engineering and Design. The proposed model numbers must be reviewed by National Grid prior to placing an order.

PRINTED COPIES ARE NOT DOCUMENT CONTROLLED. FOR THE LATEST AUTHORIZED VERSION PLEASE REFER TO THE APPROPRIATE DEPARTMENT WEBSITE OR DOCUMENTUM.		
FILE: PR.02.00.018 TECHNICAL SCOPE DOCUMENT FOR SUBSTATIONS APP FILE: MORTIMER – PROTECTION AND STATION UPGRADES FOR LINE 901 RE-CONDUCTORING	ORIGINATING DEPARTMENT: SUBSTATION ENGINEERING AND DESIGN	SPONSOR: JOHN E. GAVIN

nationalgrid	ENGINEERING DOCUMENT	Page 29 of 39
	Technical Scope Document for Substations	
	Mortimer – Protection and Station upgrades for line 901 re-conductoring	Version 1.0 - 12/17/14

16.7 **Attachment #7-1: Preliminary C&I Equipment List**

<u>Item</u>	<u>ANSI/IEEE Device Designation</u>	<u>Quantity</u>	<u>Description Comments</u>
1	Control Handles: RE-01/R104	1	Electroswitch Control Switch Relay, Series 24, Dual Trip Coil Model #: 88PD57LB Rating: 125V _{DC} Decks: 5 Indication: Green/Red/Red LED's Escutcheon: Breaker Control – Trip/Close
2	Reclose On/Off Switch: RE-43A/M/R104	1	Series 24 Latching Switch Relay W/ Annunciator Namplate Model #: 92PA03MQ Rating: 125V _{DC} Decks: 3 Escutcheon: Reclosing Switch - Manual/Auto
3	Communications Processor	1	Schweitzer Communication Processor, Model: SEL2032 Part Number: 203203X344G0XX Mounting: Horizontal Rack Mount Memory: Standard Database and Settings Storage with Archive Storage Memory Special Hardware Options: None Power Supply: 38-200 Vdc, 85-140 Vac I/O Board; Control Input Voltage: 4 Outputs, 16 Inputs; 125 Vdc* Protocol Card #1: Ethernet Card with DNP3 Protocol Connection Option for Protocol Card #1: Two 10/100BASE-T* Protocol Card #2: No Card
4	Communications Cables SEL-2032 to Relays Coaxial Cable for IRIG-B	T B D	Misc. Serial Cables Models to be determined during final design
5	RS-485 Communication Cable	T B D	Belden 9842
6	RS232 / RS485 Transceiver SEL-2886	2	Schweitzer Serial Interface Converter: SEL-2886 RS232 to RS485 conversion Port Powered

PRINTED COPIES ARE NOT DOCUMENT CONTROLLED. FOR THE LATEST AUTHORIZED VERSION PLEASE REFER TO THE APPROPRIATE DEPARTMENT WEBSITE OR DOCUMENTUM.		
FILE: PR.02.00.018 TECHNICAL SCOPE DOCUMENT FOR SUBSTATIONS APP FILE: MORTIMER – PROTECTION AND STATION UPGRADES FOR LINE 901 RE-CONDUCTORING	ORIGINATING DEPARTMENT: SUBSTATION ENGINEERING AND DESIGN	SPONSOR: JOHN E. GAVIN

nationalgrid	ENGINEERING DOCUMENT	Page 30 of 39
	Technical Scope Document for Substations Mortimer – Protection and Station upgrades for line 901 re-conductoring	Version 1.0 - 12/17/14

16.7 **Attachment #7-1: Preliminary C&I Equipment List**

<u>Item</u>	<u>ANSI/IEEE Device Designation</u>	<u>Quantity</u>	<u>Description Comments</u>
7	HMI	1	ASE SAM (SAM-900-125) Includes 17" touch screen monitor with 19" rack-mount bracket, single board Pentium IV computer with 19" rack- mount bracket, 4 serial and 2 network ports, Windows O/S, SAM alarm annunciation software, SPT data acquisition software (Support for DNP3 and Modbus, protocols: serial and network versions) Pullout Keyboard (SAM-KB) 19" Rack Mount Keyboard Touchpad and Tray
8	Telebyte Communication Signal Converters	2	Telebyte Communication Signal Converters (Model 365M), (wired for 4 ea.) Aux Power Input 12VDC w/LED Display.

Note: Please refer to ST.05.03.048 – Test Switches for metering and control handle test switch standard specifications.

PRINTED COPIES ARE NOT DOCUMENT CONTROLLED. FOR THE LATEST AUTHORIZED VERSION PLEASE REFER TO THE APPROPRIATE DEPARTMENT WEBSITE OR DOCUMENTUM.		
FILE: PR.02.00.018 TECHNICAL SCOPE DOCUMENT FOR SUBSTATIONS APP FILE: MORTIMER – PROTECTION AND STATION UPGRADES FOR LINE 901 RE-CONDUCTORING	ORIGINATING DEPARTMENT: SUBSTATION ENGINEERING AND DESIGN	SPONSOR: JOHN E. GAVIN

nationalgrid	ENGINEERING DOCUMENT	Page 31 of 39
	Technical Scope Document for Substations	
	Mortimer – Protection and Station upgrades for line 901 re-conductoring	Version 1.0 - 12/17/14

16.8 **Attachment #7-2: C&I Point Assignment (RTU1)**

Mortimer RTU1 Status Points					
IED Point No.	EMS Point No.	EMS Description	2020 Port	Input Source	Device
16	15	BKR R104			
17	16	R104 RECLOSE OFF		DI-XT3	RTU
18	17	SPARE017			
19	18	NBUS BKRAIR			
20	19	SBUS BKRAIR			

Mortimer RTU1 SBO Points					
IED Point No.	EMS Point No.	EMS Description	2020 Port	Output Source	Device
1	0	BKR R214		XT1	RTU
2	1	R214 RECLOSE OFF			
3	2	R144 RECLOSE OFF			
4	3	R233 RECLOSE OFF			
5	4	BKR R233		XT2	RTU
6	5	BKR R235			
7	6	BKR R154			
8	7	R235 RECLOSE OFF			
9	8	BKR R133		XT3	RTU
10	9	SPARE009			
11	10	BKR R134			
12	11	SPARE011			
13	12	SPARE012		XT4	RTU
14	13	BKR R104			
15	14	R104 RECLOSE OFF			
16	15	SPARE015			

PRINTED COPIES ARE NOT DOCUMENT CONTROLLED.		
FOR THE LATEST AUTHORIZED VERSION PLEASE REFER TO THE APPROPRIATE DEPARTMENT WEBSITE OR DOCUMENTUM.		
FILE: PR.02.00.018 TECHNICAL SCOPE DOCUMENT FOR SUBSTATIONS APP FILE: MORTIMER – PROTECTION AND STATION UPGRADES FOR LINE 901 RE-CONDUCTORING	ORIGINATING DEPARTMENT: SUBSTATION ENGINEERING AND DESIGN	SPONSOR: JOHN E. GAVIN

nationalgrid	ENGINEERING DOCUMENT	Page 32 of 39
	Technical Scope Document for Substations	
	Mortimer – Protection and Station upgrades for line 901 re-conductoring	Version 1.0 - 12/17/14

16.9 **Attachment #7-3: C&I Point Assignment (RTU2)**

IED Point No	EMS Point No	Mortimer RTU2 Status Points Description	2020		
			Port	Input Source	Device
	0	RTU Cutoff		Mortimer Sage RTU	Baseboard
	1	69S R/L			
	2	Fuse monitor			
	3	2020 Relay Fail			
	4	Ln 1 relay fail			
	5	Mortimer IMUX 2000 Failure			
		Mortimer (Rochester Pump) LN111 Block			
	6	Reclose Failure (MTS Card)			
		Mortimer (Rochester Pump) LN113 Block			
	7	Reclose Failure (MTS Card)			
		Mortimer (Rochester Pump) LN114 Block			
	8	Reclose Failure (MTS Card)			
	9	R194 Reclose OFF (RE-43A/M)			
	10	R124 Reclose OFF (RE-43A/M)			
	11	R144 Reclose OFF (RE-43A/M)			
	12	2032-2 Trouble			
	13	JMUX Trouble			
	14	spare			
	15	spare		▼	▼

PRINTED COPIES ARE NOT DOCUMENT CONTROLLED.		
FOR THE LATEST AUTHORIZED VERSION PLEASE REFER TO THE APPROPRIATE DEPARTMENT WEBSITE OR DOCUMENTUM.		
FILE: PR.02.00.018 TECHNICAL SCOPE DOCUMENT FOR SUBSTATIONS APP FILE: MORTIMER – PROTECTION AND STATION UPGRADES FOR LINE 901 RE-CONDUCTORING	ORIGINATING DEPARTMENT: SUBSTATION ENGINEERING AND DESIGN	SPONSOR: JOHN E. GAVIN

nationalgrid	ENGINEERING DOCUMENT	Page 33 of 39
	Technical Scope Document for Substations	
	Mortimer – Protection and Station upgrades for line 901 re-conductoring	Version 1.0 - 12/17/14

**MORTIMER RTU2 STATUS POINTS
CONTINUED**

IED Point No	EMS Point No	Description	2020		
			Port	Input Source	Device
27	157	Rochester Pump 87LB/LN114 Relay Trouble (BPRO)		Airport M1/C RTU	ST-XT-01
28	158	Rochester Pump SEL-2032 Trouble			
29	159	Rochester Pump Arbiter Clock Fault			
30	160	Rochester Pump Arbiter Clock Loss of Sat. Lock		▼	▼
48	161	R194 Reclosing Blocked (OUT103)	2020-1 p6	SEL-351A	79/R194
	162	2032-2 Comm Sts		SEL-2032-2	SEL-2032-2
0	163	LN901 LINE DIFFERENTIAL 'A' RELAY TROUBLE (87LA/LN901)			IN1
1	164	LN901 LINE DIFFERENTIAL 'B' RELAY TROUBLE (87LB/LN901)			IN2
2	165	LN901 'A' RELAY TROUBLE (94TTA/LN901)			IN3
3	166	LN901 'B' RELAY TROUBLE (94TTB/LN901)			IN4
4	167	R104 RECLOSING RELAY TROUBLE (79/R104)			IN5
5	168	LN901 'B' LOSS OF POTENTIAL (LOP)			IN6
6	169	43/87LA/LN901 Differential OFF			IN7
7	170	43/87LB/LN901 Differential OFF			IN8
8	171	43TTA/LN901 OFF			IN9
9	172	43TTB/LN901 OFF			IN10
10	173	R104 Maintenance Test Switch Position			IN11
11	174	R104 Breaker Trouble			IN12
12	175	R104 Low SF6 Gas Alarm			IN13
13	176	R104 Low SF6 Gas Lockout		▼	IN14
14	177	LN901 LINE DIFFERENTIAL 'A' RELAY COMM STATUS	2032-2 p1	SEL-411L	87LA/LN901
15	178	LN901 LINE DIFFERENTIAL 'A' RELAY COMMUNICATIONS CHANNEL TROUBLE			
16	179	LN901 'A' LOSS OF POTENTIAL (LOP)	▼	▼	▼
17	180	R104 RECLOSING RELAY COMM STATUS	2020-2 p5	SEL-351-6	79/R104
18	181	R104 RECLOSING BLOCKED (OUT103)	▼	▼	▼

PRINTED COPIES ARE NOT DOCUMENT CONTROLLED. FOR THE LATEST AUTHORIZED VERSION PLEASE REFER TO THE APPROPRIATE DEPARTMENT WEBSITE OR DOCUMENTUM.		
FILE:PR.02.00.018 TECHNICAL SCOPE DOCUMENT FOR SUBSTATIONS APP FILE: MORTIMER – PROTECTION AND STATION UPGRADES FOR LINE 901 RE-CONDUCTORING	ORIGINATING DEPARTMENT: SUBSTATION ENGINEERING AND DESIGN	SPONSOR: JOHN E. GAVIN

16.10 Attachment #7-4 : C&I Layout Diagrams

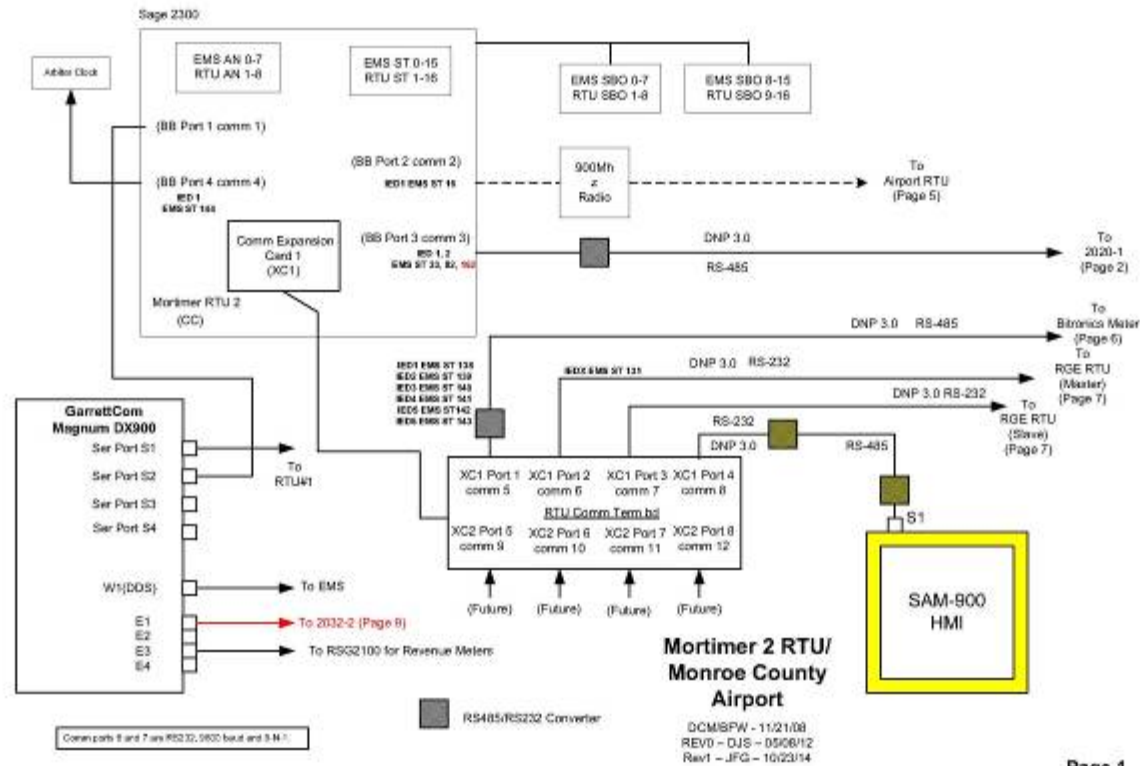

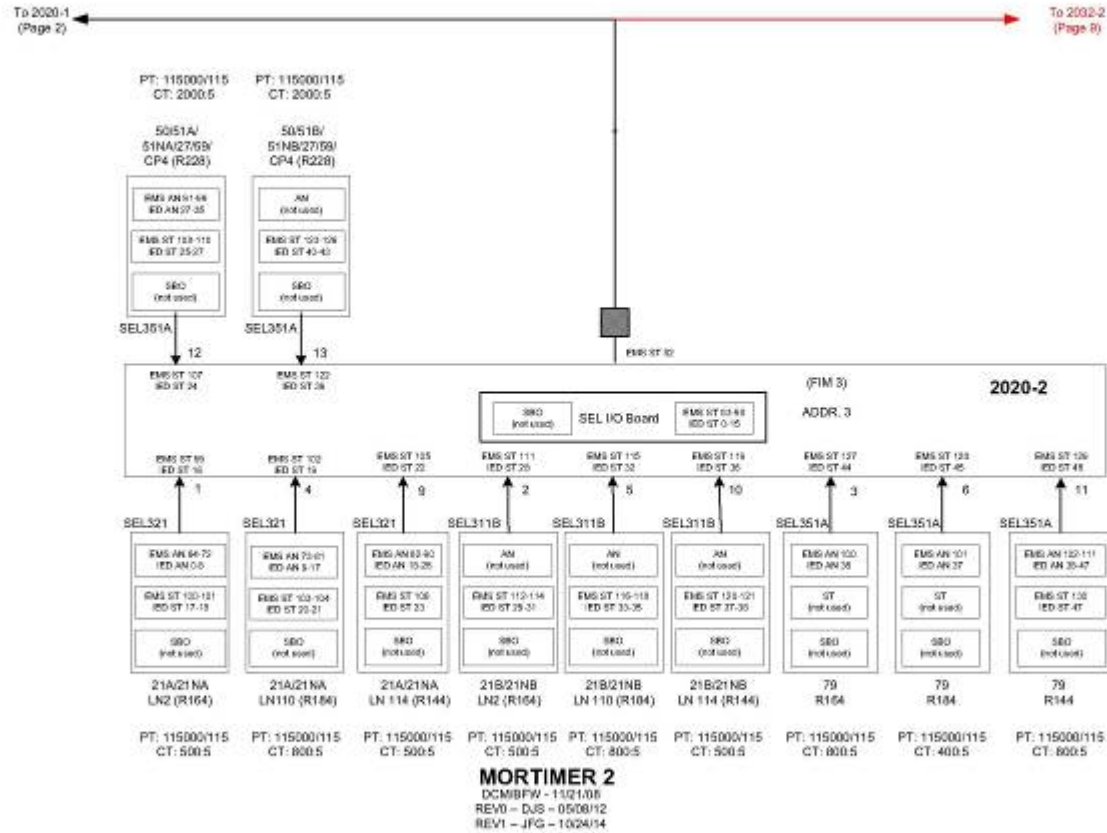

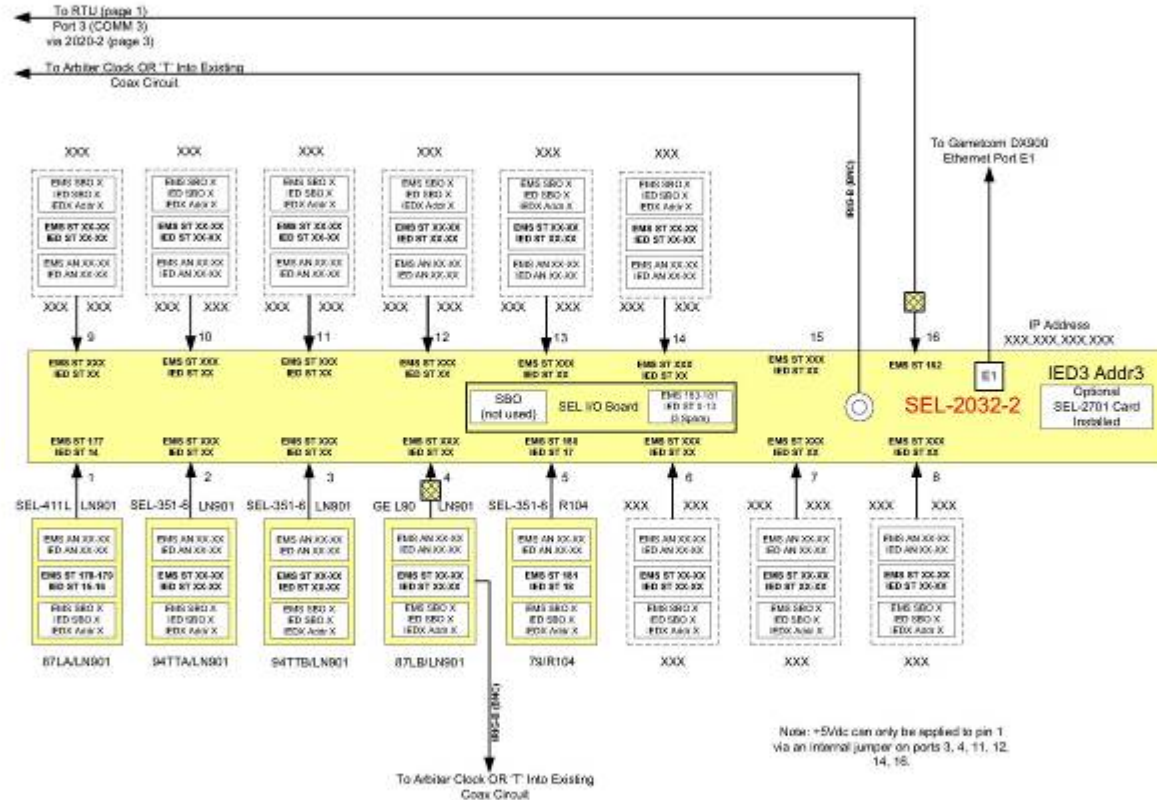

SEL-2088 RS232/RS485 Transceiver

nationalgrid	ENGINEERING DOCUMENT	Page 37 of 39
	Technical Scope Document for Substations	
	Mortimer – Protection and Station upgrades for line 901 re-conductoring	Version 1.0 - 12/17/14

16.11 **Attachment #8: Preliminary Telecom Equipment List**

<u>Item</u>	<u>ANSI/IEEE Device Designation</u>	<u>Quantity</u>	<u>Description Comments</u>
	JMUX configuration (to Be provided by RG&E)	1 1 4 4 1 1 2 1 1 1 2 1 2 2 2 1 1 1 1 1 1 1 1 1	Common Equipment shelf (B86430-01) JMUX Channel Shelf (3RU) (B86430-04) Power Converters 130V (B8643 1-03) Power Unit Paddle Boards (86431-90) Service Unit (B86434-02) Service Unit IP Service Unit Paddle Board (86434-92) OC-48 JMUX Unit 1310nm IR-I, SMF, LC (886419-01 1AA) Cable Assy Xover CAT6, RJ-45, Shielded, 7" (135-86419-01) 28VT JMUX to JIF cable (Left side) (035-86430-65) 28VT JMUX to JIF cable (Right side) (035-86430-66) CDAX Units (886486-01) CDAX Paddle Board (86486-91) DATA-NX64F Units (64-768K) (886464-02) DATA-NX64F Unit Fiber PB (C37.94 MMF) (86464-98) 4W-VP E&M Units (B86444-05) 4W-VP Split Combine Paddle Board (86444-91) VT/DSO Ribbon Cable Kit (86430-52) Computer Test Cable Kit (86430-53) 2.488Mb/s TRANSCEIVER, 131 Onm, IR-I, 13dB, SMF, LC 1RU Spacer Panel, with removable Front (PB000086) VistaNET Network Interface (VNI) RTU License
	Fiber Optic Materials (to Be provided by RG&E)	TBD 1 1 12 12 2 1	72 strand fiber optic cable, SMF-28e+, full dielectric Coming Bulk Head Housing (CCH-04U) Coming Splice Housing (CSH-03U-F) Coming Splice Trays (M67-078) Coming Bulkhead and pigtails (CCH-CPI2-A9-PO3RH) Fiber optic patch panels Circular AFL splice Can

PRINTED COPIES ARE NOT DOCUMENT CONTROLLED. FOR THE LATEST AUTHORIZED VERSION PLEASE REFER TO THE APPROPRIATE DEPARTMENT WEBSITE OR DOCUMENTUM.		
FILE:PR.02.00.018 TECHNICAL SCOPE DOCUMENT FOR SUBSTATIONS APP FILE: MORTIMER – PROTECTION AND STATION UPGRADES FOR LINE 901 RE-CONDUCTORING	ORIGINATING DEPARTMENT: SUBSTATION ENGINEERING AND DESIGN	SPONSOR: JOHN E. GAVIN

nationalgrid	ENGINEERING DOCUMENT	Page 38 of 39
	Technical Scope Document for Substations	
	Mortimer – Protection and Station upgrades for line 901 re-conductoring	Version 1.0 - 12/17/14

16.12 **Attachment #9: Preliminary Final Engineering and Design Schedule**

Engineering & Design Milestone Schedule

No	Description	Scheduled Dates/Durations ¹
1.	Relay, C&I & Telecom Design Briefs Issued (NE only)	N/A
2.	If EPC / MSA, develop EPC / MSA bid Technical document	N/A
3.	Develop planning grade estimate (Level 3 projects only)	11/14
4.	Planning Sanction and DOA approval	12/14
5.	Notification from PM to start Final Engineering & Design	1/15
6.	Issue PO to EPC / MSA consultant (if applicable)	1/15
7.	Design Kickoff Meeting (PR.02.00.013)	2/15
8.	Major equipment / material procurement completed	7/15
9.	Primary/Civil/Structural design finished	09/15
10.	AC/DC Elementaries design finished	09/15
11.	Secondary wiring design finished	09/15
12.	Primary/Civil/Structural constructability review	10/15
13.	AC/DC Elementaries constructability review	10/15
14.	Secondary wiring constructability review	10/15
15.	Primary/Civil/Structural issued for construction (IFC)	11/15
16.	AC/DC Elementaries and secondary wiring IFC	11/15
17.	Engineering & Design Complete (EDC)	12/15
18.	If outsourced construction, complete construction bid specification	12/15
19.	Input to PM for Construction Field Issue Document	12/15
20.	Develop project grade estimate (Level 3 projects only)	N/A
21.	Minor equipment / material procurement completed	12/15

NOTES:

1. For resourcing, it is preferred that we indicate the month & year instead of durations. The schedule development is based on task 5 above.
2. There may be only one or multiple constructability reviews depending on project specifics and regional needs. Customize to meet project needs. NY generally has one constructability review, if this is so put same date in for all.
3. There may be only one or multiple issue for construction (IFC) depending on project specifics and regional needs. Customize to meet project needs. NY generally issues all drawings at once, if this is so put same date in for all. EDC indicates all drawings issued for construction.

PRINTED COPIES ARE NOT DOCUMENT CONTROLLED. FOR THE LATEST AUTHORIZED VERSION PLEASE REFER TO THE APPROPRIATE DEPARTMENT WEBSITE OR DOCUMENTUM.		
FILE: PR.02.00.018 TECHNICAL SCOPE DOCUMENT FOR SUBSTATIONS APP FILE: MORTIMER – PROTECTION AND STATION UPGRADES FOR LINE 901 RE-CONDUCTORING	ORIGINATING DEPARTMENT: SUBSTATION ENGINEERING AND DESIGN	SPONSOR: JOHN E. GAVIN

nationalgrid	ENGINEERING DOCUMENT	Page 39 of 39
	Technical Scope Document for Substations	
	Mortimer – Protection and Station upgrades for line 901 re-conductoring	Version 1.0 - 12/17/14

17.0 REVISION HISTORY OF PROJECT DOCUMENT

<u>Version</u>	<u>Date</u>	<u>Description of Revision</u>
1.0	11/12/14	Initial revision of document. Based on site visit, discussions with field personnel and review of drawings.

PRINTED COPIES ARE NOT DOCUMENT CONTROLLED. FOR THE LATEST AUTHORIZED VERSION PLEASE REFER TO THE APPROPRIATE DEPARTMENT WEBSITE OR DOCUMENTUM.		
FILE: PR.02.00.018 TECHNICAL SCOPE DOCUMENT FOR SUBSTATIONS APP FILE: MORTIMER – PROTECTION AND STATION UPGRADES FOR LINE 901 RE-CONDUCTORING	ORIGINATING DEPARTMENT: SUBSTATION ENGINEERING AND DESIGN	SPONSOR: JOHN E. GAVIN

Exhibit B: Projected Milestone Schedule

PROJECTED MILESTONE SCHEDULE

Task	Milestone	Date	Responsible Party
1.	Preliminary Engineering	<u>Complete as of the Amendment Effective Date. Technical Scope Document issued.</u> 2 Months after Effective Date	Customer/Company
2.	Final Design	<u>107 Months after Amendment Effective Date</u>	Customer/Company
3.	Material & Equipment Procurement	<u>107 Months after Amendment Effective Date</u>	Company
4.	Construction	<u>130 Months after Amendment Effective Date</u>	Company
5	Close Out	<u>162 Months after Amendment Effective Date</u>	Customer / Company

The dates above represent the Parties' preliminary schedule, which is subject to adjustment, alteration, and extension. Neither Party shall be liable for failure to meet the above Preliminary Milestone Schedule, any milestone, any in-service date, or any other projected or preliminary schedule in connection with this Agreement, the Work or the Project. National Grid does not and cannot guarantee or covenant that any outage necessary in connection with the Work will occur when presently scheduled or on any other particular date or dates and shall have no liability arising from any change in the date or dates of such outages.

Exhibit C: Insurance Requirements

- Workers Compensation and Employers Liability Insurance as required by the State of **New York**. If required, coverage shall include the U.S. Longshore and Harbor Workers' Compensation Act and the Jones Act.
- Public Liability (Including Contractual Liability), covering all activities and operations to be performed by it under this Agreement, with the following minimum limits:
 - (A) Bodily Injury - \$1,000,000/\$1,000,000
Property Damage - \$1,000,000/\$1,000,000
OR
 - (B) Combined Single Limit - \$1,000,000
OR
 - (C) Bodily Injury and Property Damage per Occurrence - \$1,000,000
General Aggregate & Product Aggregate - \$2,000,000 each
- Umbrella or Excess Liability, coverage with a minimum limit of \$ 4,000,000.

1. Upon request, either Party shall promptly provide the requesting Party with either evidence of insurance or certificates of insurance evidencing the insurance coverage above. Customer shall provide such certificates or evidence of insurance to Company at the following address:

To: National Grid c/o NIAGARA MOHAWK POWER CORPORATION
Attention: Risk Management, A-4
300 Erie Boulevard West
Syracuse, NY 13202

Company shall provide such certificates or evidence of insurance to Customer at the following address:

To: RG&E
Attention: David Fingado
1300 Scottsville Road
Rochester, NY 14624

2. Should any of the above-described policies be cancelled before the expiration date thereof, notice will be delivered in accordance with the policy provisions.
3. If a party fails to secure or maintain any insurance coverage, or any insurance coverage is canceled before the completion of all services provided under this Agreement, and such party fails immediately to procure such insurance as specified herein, then the non-defaulting party has the right but not the obligation to procure such insurance and, at its option, either bill the cost thereof to the defaulting party or deduct the cost thereof from any sum due the defaulting party under this Agreement.

4. To the extent requested, both Parties shall furnish to each other copies of any accidents report(s) sent to the Party's insurance carriers covering accidents or incidents occurring in connection with or as a result of the performance of the Work for the Project under this Agreement.
5. Each Party shall comply with any governmental and/or site-specific insurance requirements even if not stated herein.
6. By the date that such coverage is required, each Party represents to the other that it will have full policy limits available and shall notify each other in writing when coverages required herein have been reduced as a result of claim payments, expenses, or both.
7. Customer shall name the Company as an additional insured for all coverages except Workers' Compensation and Employers Liability Insurance in order to provide the Company with protection from liability arising out of activities of Customer relating to the Project and associated Work.

Exhibit D: Estimated Cost Breakdown

Project Description	Project Engineer	Cost Component	Total Cost
<u>Modifications to Mortimer line 901 phase II replace R104 along with disconnects, upgrade bus to 3000 amps</u> Mortimer Station Modifications to support RG&E Station 251 and line 901 reconductoring	Tom McMahon	Hours	43000 1300
		Straight Time Rate	\$40.00
		Labor Dollars	\$ 172,000 52,000
		Labor OH Rate	0.9409
Project Risk		Labor Overhead Dollars	\$ 161,835 48,927
Low		Materials - Inventory	\$ 552,398 3,000
		Stores Handling Rate	0.12
		Stores Handling Dollars	\$ 65,928 360
Comments/Assumptions		Materials - Vendor	\$ 130,000 100,000
<u>Per pending Contract Approval by RG&E</u> New A and B protection package with relays and panels, new communication panels with IMUX and fiber distribution equipment, New 115kV dead-end structure.		Contractors	\$ 110,000 50,000
		Transportation rate	0.3407
		Transportation dollars	\$ 58,600 17,716
		CAD Transmission rate	0.1100
		Capital Overhead Dollars	\$ 31,820 11,220
		Tax Rate	0.08
		Tax total	\$ 19,200 12,000
		Total Estimated Cost	\$ 1,300,000 295,223

For the avoidance of doubt: this Exhibit provides an estimated cost breakdown of the Work Cost Estimate; the Work Cost Estimate and this Exhibit are estimates only and shall not limit Customer's obligation to pay Company for all Company Reimbursable Costs actually incurred by Company or its Affiliates.