

SERVICE AGREEMENT NO. 2634

TRANSMISSION PROJECT

INTERCONNECTION AGREEMENT

AMONG THE

NEW YORK INDEPENDENT SYSTEM OPERATOR, INC.

AND

NEW YORK STATE ELECTRIC & GAS CORPORATION

AND

NEXTERA ENERGY TRANSMISSION NEW YORK, INC.

Dated as of July 14, 2021

(Empire State Line Project)

TABLE OF CONTENTS

	Page Number
ARTICLE 1. DEFINITIONS.....	1
ARTICLE 2. EFFECTIVE DATE, TERM AND TERMINATION	8
2.1 Effective Date.....	8
2.2 Term of Agreement.....	8
2.3 Termination.....	8
2.4 Termination Costs.....	9
2.5 Disconnection.....	10
2.6 Survival.....	10
ARTICLE 3. REGULATORY FILINGS	11
ARTICLE 4. SCOPE OF SERVICE	11
4.1 Interconnection of Transmission Facilities	11
4.2 No Transmission Delivery Service.....	11
4.3 No Other Services.....	11
ARTICLE 5. NETWORK UPGRADE FACILITIES ENGINEERING, PROCUREMENT, AND CONSTRUCTION	11
5.1 Network Upgrade Facilities.....	11
5.2 General Conditions Applicable to Network Upgrade Facilities Constructed by Transmission Developer.....	12
5.3 Equipment Procurement.....	13
5.4 Construction Commencement.....	13
5.5 Work Progress.....	14
5.6 Information Exchange.....	14
5.7 Network Upgrade Facilities	14
5.8 Access Rights.....	15
5.9 Lands of Other Property Owners.....	15
5.10 Permits.....	15
5.11 Suspension.....	15
5.12 Taxes.....	16
5.13 Tax Status; Non-Jurisdictional Entities.....	18
5.14 Modification.....	19
ARTICLE 6. TESTING AND INSPECTION	20
6.1 Pre-In Service Date Testing and Modifications.....	20
6.2 Post-In-Service Date Testing and Modifications.....	20
6.3 Right to Observe Testing.....	20
6.4 Right to Inspect.....	20
ARTICLE 7. METERING.....	21
7.1 General.....	21
7.2 Check Meters.....	21
7.3 Standards.....	21
7.4 Testing of Metering Equipment.....	21
7.5 Metering Data.....	22
ARTICLE 8. COMMUNICATIONS	22
8.1 Transmission Developer Obligations.....	22

8.2	Remote Terminal Unit.....	22
8.3	No Annexation.	22
ARTICLE 9. OPERATIONS.....		23
9.1	General.	23
9.2	NYISO and Connecting Transmission Owner Obligations.	23
9.3	Transmission Developer Obligations.	23
9.4	Reserved.....	23
9.5	Outages and Interruptions.	23
9.6	Switching and Tagging Rules.	26
9.7	Disturbance Analysis Data Exchange.	26
ARTICLE 10. MAINTENANCE		27
10.1	Connecting Transmission Owner Obligations.	27
10.2	Transmission Developer Obligations.....	27
10.3	Coordination.....	27
10.4	Secondary Systems.	27
10.5	Operating and Maintenance Expenses.	27
ARTICLE 11. PERFORMANCE OBLIGATION		28
11.1	Transmission Project.....	28
11.2	Network Upgrade Facilities.	28
11.3	Reserved.....	28
11.4	Provision of Security.....	28
11.5	Forfeiture of Security.	28
11.6	Network Upgrade Facility Costs.....	29
11.7	Line Outage Costs.....	29
ARTICLE 12. INVOICE		30
12.1	General.	30
12.2	Final Invoice and Refund of Remaining Security.....	30
12.3	Payment.....	30
12.4	Disputes.....	30
ARTICLE 13. EMERGENCIES.....		31
13.1	Obligations.	31
13.2	Notice.	31
13.3	Immediate Action.....	31
13.4	NYISO, Transmission Developer, and Connecting Transmission Owner Authority.	31
13.5	Limited Liability.	32
ARTICLE 14. REGULATORY REQUIREMENTS AND GOVERNING LAW		32
14.1	Regulatory Requirements.....	32
14.2	Governing Law.....	32
ARTICLE 15. NOTICES.....		32
15.1	General.	32
15.2	Billings and Payments.....	33
15.3	Alternative Forms of Notice.	33
15.4	Operations and Maintenance Notice.	33
ARTICLE 16. FORCE MAJEURE		33
ARTICLE 17. DEFAULT		33

17.1	General	33
17.2	Right to Terminate	34
ARTICLE 18. INDEMNITY, CONSEQUENTIAL DAMAGES AND INSURANCE		34
18.1	Indemnity	34
18.2	No Consequential Damages	35
18.3	Insurance	35
ARTICLE 19. ASSIGNMENT		38
ARTICLE 20. SEVERABILITY		39
ARTICLE 21. COMPARABILITY		39
ARTICLE 22. CONFIDENTIALITY		39
22.1	Confidentiality	39
22.2	Term	39
22.3	Confidential Information	40
22.4	Scope	40
22.5	Release of Confidential Information	40
22.6	Rights	40
22.7	No Warranties	41
22.8	Standard of Care	41
22.9	Order of Disclosure	41
22.10	Termination of Agreement	41
22.11	Remedies	41
22.12	Disclosure to FERC, its Staff, or a State	42
22.13	Required Notices Upon Requests or Demands for Confidential Information	42
ARTICLE 23. TRANSMISSION DEVELOPER AND CONNECTING TRANSMISSION OWNER NOTICES OF ENVIRONMENTAL RELEASES		42
ARTICLE 24. INFORMATION REQUIREMENT		43
24.1	Information Acquisition	43
24.2	Information Submission Concerning the Network Upgrade Facilities	43
24.3	Updated Information Submission Concerning the Transmission Project	43
24.4	Information Supplementation	44
ARTICLE 25. INFORMATION ACCESS AND AUDIT RIGHTS		44
25.1	Information Access	44
25.2	Reporting of Non-Force Majeure Events	44
25.3	Audit Rights	45
25.4	Audit Rights Periods	45
25.5	Audit Results	45
ARTICLE 26. SUBCONTRACTORS		46
26.1	General	46
26.2	Responsibility of Principal	46
26.3	No Limitation by Insurance	46
ARTICLE 27. DISPUTES		46
27.1	Submission	46
27.2	External Arbitration Procedures	46
27.3	Arbitration Decisions	47
27.4	Costs	47
27.5	Termination	47

ARTICLE 28. REPRESENTATIONS, WARRANTIES AND COVENANTS	47
28.1 General.	47
ARTICLE 29. MISCELLANEOUS	48
29.1 Binding Effect.	48
29.2 Conflicts.	48
29.3 Rules of Interpretation.....	48
29.4 Compliance.	49
29.5 Joint and Several Obligations.	49
29.6 Entire Agreement.	49
29.7 No Third Party Beneficiaries.	49
29.8 Waiver.	50
29.9 Headings.....	50
29.10 Multiple Counterparts.	50
29.11 Amendment.	50
29.12 Modification by the Parties.	50
29.13 Reservation of Rights.	50
29.14 No Partnership.....	51
29.15 Other Transmission Rights.....	51

Appendices

TRANSMISSION PROJECT INTERCONNECTION AGREEMENT

THIS TRANSMISSION PROJECT INTERCONNECTION AGREEMENT (“Agreement”) is made and entered into this 14th day of July, 2021, by and among NextEra Energy Transmission New York, Inc., a corporation organized and existing under the laws of the State of New York (“Transmission Developer” with a Transmission Project), the New York Independent System Operator, Inc., a not-for-profit corporation organized and existing under the laws of the State of New York (“NYISO”), and New York State Electric & Gas Corporation a corporation organized and existing under the laws of the State of New York (“Connecting Transmission Owner”). Transmission Developer, the NYISO, or Connecting Transmission Owner each may be referred to as a “Party” or collectively referred to as the “Parties.”

RECITALS

WHEREAS, NYISO operates the New York State Transmission System and Connecting Transmission Owner owns certain facilities included in the New York State Transmission System;

WHEREAS, Transmission Developer intends to construct, own, and operate a Transmission Project described in Appendix C to this Agreement that will interconnect to the New York State Transmission System;

WHEREAS, portions of the Transmission Project will interconnect to the New York State Transmission System at facilities owned and operated by the Connecting Transmission Owner;

WHEREAS, the Transmission Project was evaluated in the NYISO’s Transmission Interconnection Procedures located in Attachment P of the NYISO OATT;

WHEREAS, Transmission Interconnection Studies determined that certain Network Upgrade Facilities were required on the Connecting Transmission Owner’s system for the Transmission Project to connect reliably to the system in a manner that meets the NYISO Transmission Interconnection Standard; and

WHEREAS, Transmission Developer, NYISO, and Connecting Transmission Owner have agreed to enter into this Agreement for the purpose of interconnecting the Transmission Project with the Connecting Transmission Owner’s facilities included in the New York State Transmission System;

NOW, THEREFORE, in consideration of and subject to the mutual covenants contained herein, it is agreed:

ARTICLE 1. DEFINITIONS

Whenever used in this Agreement with initial capitalization, the following terms shall have the meanings specified in this Article 1. Terms used in this Agreement with initial capitalization that are not defined in this Article 1 shall have the meanings specified in Section 1 of the ISO OATT,

Section 22.1 of Attachment P of the ISO OATT, Section 25.1.2 of Attachment S of the ISO OATT, the body of the Transmission Interconnection Procedures, or the body of this Agreement.

Affected System shall mean an electric system other than the transmission system owned, controlled or operated by the Connecting Transmission Owner that may be affected by the proposed interconnection.

Affected System Operator shall mean the entity that operates an Affected System.

Affected Transmission Owner shall mean the New York public utility or authority (or its designated agent) other than the Connecting Transmission Owner that (i) owns facilities used for the transmission of Energy in interstate commerce and provides Transmission Service under the Tariff, and (ii) owns, leases or otherwise possesses an interest in a portion of the New York State Transmission System where System Deliverability Upgrades, System Upgrade Facilities, or Network Upgrade Facilities are or will be installed pursuant to Attachment P, Attachment X, Attachment Z, or Attachment S to the ISO OATT.

Affiliate shall mean, with respect to a person or entity, any individual, corporation, partnership, firm, joint venture, association, joint-stock company, trust or unincorporated organization, directly or indirectly controlling, controlled by, or under common control with, such person or entity. The term “control” shall mean the possession, directly or indirectly, of the power to direct the management or policies of a person or an entity. A voting interest of ten percent or more shall create a rebuttable presumption of control.

Applicable Laws and Regulations shall mean all duly promulgated applicable federal, state and local laws, regulations, rules, ordinances, codes, decrees, judgments, directives, or judicial or administrative orders, permits and other duly authorized actions of any Governmental Authority, including but not limited to Environmental Law.

Applicable Reliability Councils shall mean the NERC, the NPCC and the NYSRC.

Applicable Reliability Standards shall mean the requirements and guidelines of the Applicable Reliability Councils, and the Transmission District to which the Transmission Developer’s Transmission Project is directly interconnected, as those requirements and guidelines are amended and modified and in effect from time to time; provided that no Party shall waive its right to challenge the applicability or validity of any requirement or guideline as applied to it in the context of this Agreement.

Base Case shall mean the base case power flow, short circuit, and stability data bases used for the Transmission Interconnection Studies by the NYISO, Connecting Transmission Owner, or the Transmission Developer, as described in Section 22.6.1 of the Transmission Interconnection Procedures.

Breach shall mean the failure of a Party to perform or observe any material term or condition of this Agreement.

Breaching Party shall mean a Party that is in Breach of this Agreement.

Business Day shall mean Monday through Friday, excluding federal holidays.

Calendar Day shall mean any day including Saturday, Sunday or a federal holiday.

Confidential Information shall mean any information that is defined as confidential by Article 22 of this Agreement.

Connecting Transmission Owner shall mean the New York public utility or authority (or its designated agent) that (i) owns facilities used for the transmission of Energy in interstate commerce and provides Transmission Service under the Tariff, (ii) owns, leases or otherwise possesses an interest in the portion of the New York State Transmission System at the Point(s) of Interconnection, and (iii) is a Party to this Agreement. For purposes of this Agreement, the Connecting Transmission Owner is defined in the introductory paragraph.

Control Area shall mean an electric power system or combination of electric power systems to which a common automatic generation control scheme is applied in order to: (1) match, at all times, the power output of the Generators within the electric power system(s) and capacity and energy purchased from entities outside the electric power system(s), with the Load within the electric power system(s); (2) maintain scheduled interchange with other Control Areas, within the limits of Good Utility Practice; (3) maintain the frequency of the electric power system(s) within reasonable limits in accordance with Good Utility Practice; and (4) provide sufficient generating capacity to maintain Operating Reserves in accordance with Good Utility Practice. A Control Area must be certified by the NPCC.

Default shall mean the failure of a Party in Breach of this Agreement to cure such Breach in accordance with Article 17 of this Agreement.

Development Agreement shall mean the agreement executed between the NYISO and the Transmission Developer concerning the development of the Transmission Project, dated June 29, 2019, as it may be amended from time to time.

Effective Date shall mean the date on which this Agreement becomes effective upon execution by the Parties, subject to acceptance by the Commission, or if filed unexecuted, upon the date specified by the Commission.

Emergency shall mean any abnormal condition or situation which the Connecting Transmission Owner, Transmission Developer, or NYISO, in their sole discretion, deems imminently likely to endanger life or property, or adversely affect or impair the New York State Transmission System, Connecting Transmission Owner's electrical system, Transmission Project, or the electrical or transmission systems of others to which they are directly or indirectly connected, which requires immediate automatic or manual action to correct. Such an abnormal system condition or situation includes, without limitation, overloading or potential overloading (exceeding thermal limits of pre- and post-contingency), excessive voltage drop, exceeding voltage limits as defined by the NYISO, Transmission Developer, or Connecting Transmission Owner, load shedding, voltage reduction, operating reserve deficiencies, frequency deviations, over-generation or other non-normal conditions. Economic hardship of a Party will not constitute an "Emergency."

Emergency State shall mean the condition or state that the New York State Power System is in when an abnormal condition occurs that requires automatic or immediate manual action to prevent or limit loss of the New York State Transmission System or Generators that could adversely affect the reliability of the New York State Power System.

Environmental Law shall mean Applicable Laws and Regulations relating to pollution or protection of the environment or natural resources.

Facilities Study shall mean the study conducted pursuant to Section 22.9 of Attachment P of the NYISO OATT to determine a list of facilities required to reliably interconnect the Transmission Project (including Network Upgrade Facilities) as identified in the System Impact Study, the cost of those facilities, and the time required to interconnect the Transmission Project with the New York State Transmission System.

Facilities Study Agreement shall mean the agreement described in Section 22.9.1 of Attachment P of the NYISO OATT for conducting the Facilities Study.

Federal Power Act shall mean the Federal Power Act, as amended, 16 U.S.C. §§ 791a *et seq.* (“FPA”).

FERC shall mean the Federal Energy Regulatory Commission (“Commission”) or its successor.

Force Majeure shall mean any act of God, labor disturbance, act of the public enemy, war, insurrection, riot, fire, storm or flood, explosion, breakage or accident to machinery or equipment, any order, regulation or restriction imposed by governmental, military or lawfully established civilian authorities, or any other cause beyond a Party’s control. A Force Majeure event does not include acts of negligence or intentional wrongdoing by the Party claiming Force Majeure.

Good Utility Practice shall mean any of the practices, methods and acts engaged in or approved by a significant portion of the electric industry during the relevant time period, or any of the practices, methods and acts which, in the exercise of reasonable judgment in light of the facts known at the time the decision was made, could have been expected to accomplish the desired result at a reasonable cost consistent with good business practices, reliability, safety and expedition. Good Utility Practice is not intended to be limited to the optimum practice, method, or act to the exclusion of all others, but rather to delineate acceptable practices, methods, or acts generally accepted in the region.

Governmental Authority shall mean any federal, state, local or other governmental regulatory or administrative agency, court, commission, department, board, or other governmental subdivision, legislature, rulemaking board, tribunal, or other governmental authority having jurisdiction over any of the Parties, their respective facilities, or the respective services they provide, and exercising or entitled to exercise any administrative, executive, police, or taxing authority or power; provided, however, that such term does not include Transmission Developer, NYISO, Affected Transmission Owner, Connecting Transmission Owner, or any Affiliate thereof.

Hazardous Substances shall mean any chemicals, materials or substances defined as or included in the definition of “hazardous substances,” “hazardous wastes,” “hazardous materials,” “hazardous constituents,” “restricted hazardous materials,” “extremely hazardous substances,” “toxic substances,” “radioactive substances,” “contaminants,” “pollutants,” “toxic pollutants” or words of similar meaning and regulatory effect under any applicable Environmental Law, or any other chemical, material or substance, exposure to which is prohibited, limited or regulated by any applicable Environmental Law.

Initial Synchronization Date(s) shall mean the date(s) upon which the Transmission Project and Network Upgrade Facilities, as applicable, are initially synchronized with the New York State Transmission System and upon which Trial Operation begins, which date(s) shall be set forth in the milestones table in Appendix B. The Transmission Developer must provide notice of the Initial Synchronization Date(s) to the other Parties in the form of Appendix E-1 to this Agreement.

In-Service Date(s) shall mean the date(s) upon which the Transmission Project and Network Upgrade Facilities, as applicable, are energized consistent with the provisions of this Agreement and available to provide Transmission Service under the NYISO’s Tariffs, which date(s) shall be set forth in the milestones table in Appendix B. The Transmission Developer must provide notice of the In-Service Date(s) to the other Parties in the form of Appendix E-2 to this Agreement.

IRS shall mean the Internal Revenue Service.

Metering Equipment shall mean all metering equipment installed or to be installed at the Transmission Project pursuant to this Agreement, including but not limited to instrument transformers, MWh-meters, data acquisition equipment, transducers, remote terminal unit, communications equipment, phone lines, and fiber optics.

Metering Points shall mean the location(s) identified by the NYISO for any Metering Equipment associated with the Transmission Project that are required for the Transmission Project to provide zonal or subzonal metering data.

NERC shall mean the North American Electric Reliability Council or its successor organization.

Network Upgrade Facilities shall mean the least costly configuration of commercially available components of electrical equipment that can be used, consistent with Good Utility Practice and Applicable Reliability Requirements, to make the modifications or additions to the New York State Transmission System that are required for the proposed Transmission Project to connect reliably to the system in a manner that meets the NYISO Transmission Interconnection Standard. For purposes of this Agreement, the Network Upgrade Facilities are described in Appendix A of this Agreement.

New York State Transmission System shall mean the entire New York State electric transmission system, which includes (i) the Transmission Facilities Under ISO Operational Control; (ii) the Transmission Facilities Requiring ISO Notification; and (iii) all remaining transmission facilities within the New York Control Area.

Notice of Dispute shall mean a written notice of a dispute or claim that arises out of or in connection with this Agreement or its performance.

NPCC shall mean the Northeast Power Coordinating Council or its successor organization.

NUF Estimated Total Costs shall be the costs for the engineering, procurement, and construction of the Network Upgrade Facilities, which costs were identified in the Facilities Study and are specified in Appendix A.

NYISO Transmission Interconnection Standard shall mean the reliability standard that must be met by any Transmission Project proposing to connect to the New York State Transmission System. The standard is designed to ensure reliable access by the proposed project to the New York State Transmission System.

NYSRC shall mean the New York State Reliability Council or its successor organization.

Operating Agreement shall mean the Operating Agreement that the Transmission Developer is required to enter into with the NYISO concerning the operation of its transmission facilities in accordance with the requirements in Section 31.1.7.3 of Attachment Y of the OATT, as such agreement may be amended from time to time.

Party or Parties shall mean NYISO, Connecting Transmission Owner, or Transmission Developer or any combination of the above.

Point(s) of Change of Ownership shall mean the point(s), as set forth in Appendix C to this Agreement, where the Transmission Developer's Transmission Project connect to the Connecting Transmission Owner's system.

Point(s) of Interconnection shall mean the point(s), as set forth in Appendix C to this Agreement, where the Transmission Developer's Transmission Project connect to the New York State Transmission System.

Reasonable Efforts shall mean, with respect to an action required to be attempted or taken by a Party under this Agreement, efforts that are timely and consistent with Good Utility Practice and are otherwise substantially equivalent to those a Party would use to protect its own interests.

Security shall mean a bond, irrevocable letter of credit, parent company guarantee or other form of security from an entity with an investment grade rating, executed for the benefit of the Connecting Transmission Owner, meeting the commercially reasonable requirements of the Connecting Transmission Owner with which it is required to be posted pursuant to Article 11.4, and consistent with the Uniform Commercial Code of the jurisdiction identified in Article 14.2.1 of this Agreement.

Services Tariff shall mean the NYISO Market Administration and Control Area Tariff, as filed with the Commission, and as amended or supplemented from time to time, or any successor tariff thereto.

System Impact Study shall mean the study conducted pursuant to Section 22.8 of Attachment P of the NYISO OATT that evaluates the impact of the proposed Transmission Project on the safety and reliability of the New York State Transmission System and, if applicable, and Affected System, to determine what Network Upgrade Facilities are needed for the proposed Transmission Project to connect reliably to the New York State Transmission System in a manner that meets the NYISO Transmission Interconnection Standard.

System Impact Study Agreement shall mean the agreement described in Section 22.8.1 of Attachment P of the NYISO OATT for conducting the System Impact Study.

System Protection Facilities shall mean the equipment, including necessary protection signal communications equipment, required to (1) protect the New York State Transmission System from faults or other electrical disturbances occurring at the Transmission Project and (2) protect the Transmission Project from faults or other electrical system disturbances occurring on the New York State Transmission System or on other delivery systems or other generating systems to which the New York State Transmission System is directly connected.

Tariff shall mean the NYISO Open Access Transmission Tariff (“OATT”), as filed with the Commission, and as amended or supplemented from time to time, or any successor tariff.

Transmission Developer shall mean an entity that proposes to interconnect its Transmission Project to the New York State Transmission System in compliance with the NYISO Transmission Interconnection Standard. For purposes of this Agreement, the Transmission Developer is defined in the introductory paragraph.

Transmission Interconnection Application shall mean the Transmission Developer’s request, in the form of Appendix 1 to the Transmission Interconnection Procedures, to interconnect a Transmission Project to the New York State Transmission System.

Transmission Interconnection Procedures (“TIP”) shall mean the interconnection procedures applicable to a Transmission Interconnection Application pertaining to a Transmission Project that are included in Attachment P of the NYISO OATT.

Transmission Interconnection Study shall mean any of the following studies: the Optional Feasibility Study, the System Impact Study, and the Facilities Study described in the Transmission Interconnection Procedures.

Transmission Project shall mean the Transmission Developer’s proposed transmission facility or facilities that collectively satisfy the definition of Transmission Project in Section 22.3.1 of Attachment P of the NYISO OATT. For purposes of this Agreement, the Transmission Project is described in Appendix C of this Agreement.

Transmission Project Interconnection Agreement shall mean this interconnection agreement applicable to the interconnection of the Transmission Project to the New York State Transmission System.

Trial Operation shall mean the period(s) during which Transmission Developer is engaged in on-site test operations and commissioning of the Transmission Project or Network Upgrade Facilities prior to the In-Service Date.

ARTICLE 2. EFFECTIVE DATE, TERM AND TERMINATION

2.1 Effective Date.

This Agreement shall become effective upon execution by the Parties, subject to acceptance by FERC, or if filed unexecuted, upon the date specified by FERC. The NYISO and Connecting Transmission Owner shall promptly file this Agreement with FERC upon execution in accordance with Article 3.

2.2 Term of Agreement.

Subject to the provisions of Article 2.3, this Agreement shall remain in effect for a period of twenty five (25) years from the Effective Date and shall be automatically renewed for each successive one-year period thereafter.

2.3 Termination.

2.3.1 Written Notice.

2.3.1.1 Written Notice of Termination

This Agreement may be terminated: (i) by any Party after giving the other Parties ninety (90) Calendar Days advance written notice following the termination of the Development Agreement prior to the completion of its term, subject to the suspension requirements in Article 2.3.1.2 below; or (ii) by the mutual agreement in writing of all Parties.

2.3.1.2 Suspension Period for Project Transfer

2.3.1.2.1 If the Development Agreement is terminated prior to the completion of its term and the NYISO exercises its right under the Development Agreement and the Tariff to request that a developer other than the Transmission Developer complete the Transmission Project, this Agreement shall be suspended. The suspension period will last until either: (i) the NYISO issues a written determination that the Transmission Project cannot be transferred to another developer and will not proceed, or (ii) the Transmission Developer completes the assignment of this Agreement to a new developer selected by the NYISO as set forth in Article 2.3.1.2.3. During the suspension period, the running of any advanced notice of termination time period pursuant to Article 2.3.1.1 will be paused. The Agreement shall not be terminated during the suspension period without the written agreement of all Parties.

2.3.1.2.2 During the suspension period, the Transmission Developer and Connecting Transmission Owner shall suspend all work associated with the construction and installation of the Network Upgrade Facilities required for only that Transmission Developer under this Agreement with the condition that the New York State Transmission System shall be left in a

safe and reliable condition in accordance with Good Utility Practice and the safety and reliability criteria of Connecting Transmission Owner and NYISO. In such event, Transmission Developer shall be responsible for all reasonable and necessary costs and/or obligations in accordance with this Agreement, including those which Connecting Transmission Owner (i) has incurred pursuant to this Agreement prior to the suspension and (ii) incurs in suspending such work, including any costs incurred to perform such work as may be necessary to ensure the safety of persons and property and the integrity of the New York State Transmission System during such suspension and, if applicable, any costs incurred in connection with the cancellation or suspension of material, equipment and labor contracts which Connecting Transmission Owner cannot reasonably avoid; *provided, however*, that prior to canceling or suspending any such material, equipment or labor contract, Connecting Transmission Owner shall obtain Transmission Developer's authorization to do so, which authorization shall not unreasonably be withheld, conditioned or delayed.

2.3.1.2.3 If, pursuant to its Tariff, the NYISO selects a new developer to complete the Transmission Project, Transmission Developer shall coordinate with the new developer concerning the assignment of this Agreement to the new developer pursuant to the assignment requirements in Article 19 of this Agreement. All liabilities under this Agreement existing prior to such transfer shall remain with the Transmission Developer, unless otherwise agreed upon by the Transmission Developer and the new developer as part of their good faith negotiations regarding the transfer.

2.3.2 Default.

Any Party may terminate this Agreement in accordance with Article 17.

2.3.3 Compliance.

Notwithstanding Articles 2.3.1 and 2.3.2, no termination of this Agreement shall become effective until the Parties have complied with all Applicable Laws and Regulations applicable to such termination, including the filing with FERC of a notice of termination of this Agreement, which notice has been accepted for filing by FERC.

2.4 Termination Costs.

If a Party elects to terminate this Agreement pursuant to Article 2.3.1 above, the Transmission Developer shall be responsible for all costs that are the responsibility of the Transmission Developer under this Agreement that are incurred by the Transmission Developer or the other Parties through the date, as applicable, of the other Parties' receipt of a Party's notice of termination or of the Parties' mutual agreement to terminate the agreement. Such costs include any cancellation costs relating to orders or contracts. In the event of termination by the Transmission Developer, all Parties shall use commercially Reasonable Efforts to mitigate the costs, damages and charges arising as a consequence of termination. Upon termination of this Agreement, unless otherwise ordered or approved by FERC:

2.4.1 With respect to any portion of the Network Upgrade Facilities that have not yet been constructed or installed, but that is being relied upon by other projects in the manner

described in Article 11.5 of this Agreement, Transmission Developer shall forfeit any remaining Security in accordance with the requirements in Article 11.5.

2.4.2 With respect to any portion of the Network Upgrade Facilities that has not yet been constructed or installed and is not being relied upon by other projects in the manner described in Article 11.5 of this Agreement, the Connecting Transmission Owner shall to the extent possible and with Transmission Developer's authorization cancel any pending orders of, or return, any materials or equipment for, or contracts for construction of, such facilities; provided that in the event Transmission Developer elects not to authorize such cancellation, Transmission Developer shall assume all payment obligations with respect to such materials, equipment, and contracts, and the Connecting Transmission Owner shall deliver such material and equipment, and, if necessary, assign such contracts, to Transmission Developer as soon as practicable, at Transmission Developer's expense. To the extent that Transmission Developer has already paid Connecting Transmission Owner for any or all such costs of materials or equipment not taken by Transmission Developer, Connecting Transmission Owner shall promptly refund such amounts to Transmission Developer, less any costs, including penalties incurred by the Connecting Transmission Owner to cancel any pending orders of or return such materials, equipment, or contracts.

2.4.3 Connecting Transmission Owner may, at its option, retain any portion of such materials, equipment, or facilities that Transmission Developer chooses not to accept delivery of, in which case Connecting Transmission Owner shall be responsible for all costs associated with procuring such materials, equipment, or facilities.

2.4.4 With respect to any portion of the Network Upgrade Facilities, and any other facilities already installed or constructed pursuant to the terms of this Agreement, Transmission Developer shall be responsible for all costs associated with the removal, relocation or other disposition or retirement of such materials, equipment, or facilities.

2.5 Disconnection.

Upon termination of this Agreement, Transmission Developer and Connecting Transmission Owner will take all appropriate steps to disconnect the Transmission Developer's Transmission Project from the New York State Transmission System and to perform such work as may be necessary to ensure that the New York State Transmission System shall be left in a safe and reliable condition in accordance with Good Utility Practice and the safety and reliability criteria of Connecting Transmission Owner and NYISO. All costs required to effectuate such disconnection shall be borne by the Transmission Developer, unless such termination resulted from the Connecting Transmission Owner's Default of this Agreement.

2.6 Survival.

This Agreement shall continue in effect after termination to the extent necessary to provide for final billings and payments and for costs incurred hereunder; including billings and payments pursuant to this Agreement and Transmission Developer's satisfaction of the Security requirements in Article 11.5; to permit the determination and enforcement of liability and indemnification obligations arising from acts or events that occurred while this Agreement was

in effect; and to permit Transmission Developer and Connecting Transmission Owner each to have access to the lands of the other pursuant to this Agreement or other applicable agreements, to disconnect, remove or salvage its own facilities and equipment.

ARTICLE 3. REGULATORY FILINGS

NYISO and Connecting Transmission Owner shall file this Agreement (and any amendment hereto) with the appropriate Governmental Authority, if required. Any information related to studies for interconnection asserted by Transmission Developer to contain Confidential Information shall be treated in accordance with Article 22 of this Agreement and Attachment F to the ISO OATT. If the Transmission Developer has executed this Agreement, or any amendment thereto, the Transmission Developer shall reasonably cooperate with NYISO and Connecting Transmission Owner with respect to such filing and to provide any information reasonably requested by NYISO and Connecting Transmission Owner needed to comply with Applicable Laws and Regulations.

ARTICLE 4. SCOPE OF SERVICE

4.1 Interconnection of Transmission Facilities

The Transmission Developer's Transmission Project and the Connecting Transmission Owner's transmission system shall interconnect at the Points of Interconnection set forth in Appendix C of this Agreement in accordance with the terms and conditions of this Agreement.

4.2 No Transmission Delivery Service.

The execution of this Agreement does not constitute a request for, nor agreement to provide, any Transmission Service under the ISO OATT, and does not convey any right to deliver electricity to any specific customer or Point of Delivery.

4.3 No Other Services.

The execution of this Agreement does not constitute a request for, nor agreement to provide Energy, any Ancillary Services or Installed Capacity under the NYISO Market Administration and Control Area Services Tariff ("Services Tariff").

ARTICLE 5. NETWORK UPGRADE FACILITIES ENGINEERING, PROCUREMENT, AND CONSTRUCTION

5.1 Network Upgrade Facilities.

Unless otherwise mutually agreed to by Transmission Developer and Connecting Transmission Owner, Transmission Developer shall select the In-Service Date and Initial Synchronization Date of the Network Upgrade Facilities, and such dates shall be set forth in Appendix B hereto. Transmission Developer shall design, procure, construct, and install the Network Upgrade Facilities as described in Appendix A hereto. Transmission Developer shall use Reasonable Efforts to complete the Network Upgrade Facilities by the dates set forth in Appendix B hereto. The Connecting Transmission Owner shall not be required to undertake any

action which is inconsistent with its standard safety practices, its material and equipment specifications, its design criteria and construction procedures, its labor agreements, and Applicable Laws and Regulations. In the event the Transmission Developer reasonably expects that it will not be able to complete the Network Upgrade Facilities by the specified dates, Transmission Developer shall promptly provide written notice to the Connecting Transmission Owner and NYISO, and shall undertake Reasonable Efforts to meet the earliest dates thereafter.

5.2 General Conditions Applicable to Network Upgrade Facilities Constructed by Transmission Developer.

As Transmission Developer is responsible for the design, procurement and construction of the Network Upgrade Facilities as set forth in Appendix A, the following conditions apply:

5.2.1 Transmission Developer shall engineer, procure equipment, and construct the Network Upgrade Facilities (or portions thereof) using Good Utility Practice and using standards and specifications provided by the Connecting Transmission Owner;

5.2.2 Transmission Developer's engineering, procurement and construction of the Network Upgrade Facilities shall comply with all requirements of law to which Connecting Transmission Owner would otherwise have been subject in the engineering, procurement or construction of the Network Upgrade Facilities;

5.2.3 Connecting Transmission Owner shall review and approve the engineering design, equipment acceptance tests, and the construction of the Network Upgrade Facilities;

5.2.4 Prior to commencement of construction, Transmission Developer shall provide to Connecting Transmission Owner and NYISO a schedule for construction of the Network Upgrade Facilities, and shall promptly respond to requests for information from Connecting Transmission Owner or NYISO;

5.2.5 At any time during construction, Connecting Transmission Owner shall have the right to gain unrestricted access to the Network Upgrade Facilities and to conduct inspections of the same;

5.2.6 At any time during construction, should any phase of the engineering, equipment procurement, or construction of the Network Upgrade Facilities not meet the standards and specifications provided by Connecting Transmission Owner, the Transmission Developer shall be obligated to remedy deficiencies in that portion of the Network Upgrade Facilities to Connecting Transmission Owner's satisfaction;

5.2.7 Transmission Developer shall indemnify Connecting Transmission Owner and NYISO for claims arising from the Transmission Developer's construction of Network Upgrade Facilities under procedures applicable to Article 18.1 Indemnity;

5.2.8 Transmission Developer shall transfer control of Network Upgrade Facilities to the Connecting Transmission Owner as specified in Appendix C;

5.2.9 Transmission Developer shall transfer ownership of the Network Upgrade Facilities to Connecting Transmission Owner as specified in Appendix C;

5.2.10 Connecting Transmission Owner shall approve and accept for operation and maintenance the Network Upgrade Facilities as specified in Appendix C, to the extent engineered, procured, and constructed in accordance with this Article 5.2;

5.2.11 Transmission Developer shall deliver to NYISO and Connecting Transmission Owner “as built” drawings, information, and any other documents that are reasonably required by NYISO or Connecting Transmission Owner to assure that the Network Upgrade Facilities are built to the standards and specifications required by Connecting Transmission Owner; and

5.2.12 The Transmission Developer shall be responsible for the costs that Connecting Transmission Owner incurs in executing the responsibilities enumerated to Connecting Transmission Owner under Article 5.2. The Connecting Transmission Owner shall invoice Transmission Developer for such costs pursuant to Article 12.

5.3 Equipment Procurement.

The Transmission Developer shall commence design of the Network Upgrade Facilities and procure necessary equipment as soon as practicable after all of the following conditions are satisfied, unless the Transmission Developer and Connecting Transmission Owner otherwise agree in writing:

5.3.1 NYISO and Connecting Transmission Owner have completed the Facilities Study pursuant to the Facilities Study Agreement; and

5.3.2 The NYISO has completed the required cost allocation analyses, and Transmission Developer has provided Security to the Connecting Transmission Owner in accordance with Article 11.4 by the date specified in Appendix B hereto.

5.4 Construction Commencement.

The Transmission Developer shall commence construction of the Network Upgrade Facilities as soon as practicable after the following additional conditions are satisfied:

5.4.1 Approval of the appropriate Governmental Authority has been obtained for any facilities requiring regulatory approval;

5.4.2 Necessary real property rights and rights-of-way have been obtained, to the extent required for the construction of a discrete aspect of the Network Upgrade Facilities; and

5.4.3 The Transmission Developer has provided Security to the Connecting Transmission Owner in accordance with Article 11.4 by the dates specified in Appendix B hereto.

5.5 Work Progress.

The Transmission Developer will keep the NYISO and Connecting Transmission Owner advised periodically as to the progress of the design, procurement and construction efforts of the Transmission Project and Network Upgrade Facilities. The NYISO and Connecting Transmission Owner may, at any time, request a progress report from the Transmission Developer.

5.6 Information Exchange.

As soon as reasonably practicable after the Effective Date, the Transmission Developer and Connecting Transmission Owner shall exchange information, and provide NYISO the same information, regarding the design and compatibility of the Transmission Project and Network Upgrade Facilities and the compatibility of the Transmission Project and Network Upgrade Facilities with the New York State Transmission System, and shall work diligently and in good faith to make any necessary design changes.

5.7 Network Upgrade Facilities

Transmission Developer shall submit initial and final specifications for the Network Upgrade Facilities to Connecting Transmission Owner and NYISO for review and comments pursuant to the dates set forth in Appendix B. Connecting Transmission Owner and NYISO shall review such specifications to ensure that the Network Upgrade Facilities are compatible with the technical specifications, operational control, and safety requirements of the Connecting Transmission Owner and NYISO and comment on such specifications pursuant to the dates set forth in Appendix B. All specifications provided hereunder shall be deemed to be Confidential Information.

The review of Transmission Developer's final specifications by Connecting Transmission Owner and NYISO shall not be construed as confirming, endorsing, or providing a warranty as to the design, fitness, safety, durability or reliability of the Transmission Project or Network Upgrade Facilities. Transmission Developer shall make such changes to the Network Upgrade Facilities as may reasonably be required by Connecting Transmission Owner or NYISO, in accordance with Good Utility Practice, to ensure that the Network Upgrade Facilities are compatible with the technical specifications, operational control, and safety requirements of the Connecting Transmission Owner and NYISO.

The Transmission Developer shall design and construct the Network Upgrade Facilities in accordance with Good Utility Practice and the Connecting Transmission Owner's standards and specifications. Transmission Developer shall deliver to the Connecting Transmission Owner and NYISO pursuant to the dates set forth in Appendix B "as-built" drawings, information and documents for the Network Upgrade Facilities.

The Connecting Transmission Owner shall transfer operational control of the Network Upgrade Facilities to the NYISO upon completion of such facilities.

5.8 Access Rights.

Upon reasonable notice and supervision by the Granting Party, and subject to any required or necessary regulatory approvals, the Connecting Transmission Owner and Transmission Developer (“Granting Party”) shall each furnish to the other Parties (“Access Party”) at no cost any rights of use, licenses, rights of way and easements with respect to lands owned or controlled by the Granting Party, its agents (if allowed under the applicable agency agreement), or any Affiliate, that are necessary to enable the Access Party to obtain ingress and egress at the Point(s) of Interconnection to construct, operate, maintain, repair, test (or witness testing), inspect, replace or remove facilities and equipment to: (i) interconnect the Transmission Project and Network Upgrade Facilities with the New York State Transmission System; (ii) operate and maintain the Transmission Project, Network Upgrade Facilities, and the New York State Transmission System; and (iii) disconnect or remove the Access Party’s facilities and equipment upon termination of this Agreement. In exercising such licenses, rights of way and easements, the Access Party shall not unreasonably disrupt or interfere with normal operation of the Granting Party’s business and shall adhere to the safety rules and procedures established in advance, as may be changed from time to time, by the Granting Party and provided to the Access Party. The Access Party shall indemnify the Granting Party against all claims of injury or damage from third parties resulting from the exercise of the access rights provided for herein.

5.9 Lands of Other Property Owners.

If any part of the Network Upgrade Facilities is to be installed on property owned by persons other than Transmission Developer or Connecting Transmission Owner, the Connecting Transmission Owner agrees, to the extent permitted by applicable law, at Transmission Developer’s expense to use efforts, similar in nature and extent to those that it typically undertakes for its own or affiliated generation, including use of its eminent domain authority, and to the extent consistent with state law, to procure from such persons any rights of use, licenses, rights of way and easements that are necessary to construct, operate, maintain, test, inspect, replace or remove the Network Upgrade Facilities upon such property.

5.10 Permits.

NYISO, Connecting Transmission Owner and Transmission Developer shall cooperate with each other in good faith in obtaining all permits, licenses and authorizations that are necessary to accomplish the interconnection in compliance with Applicable Laws and Regulations. With respect to this paragraph, Connecting Transmission Owner shall provide permitting assistance to the Transmission Developer comparable to that provided to the Connecting Transmission Owner’s own, or an Affiliate’s, generation or transmission facilities, if any.

5.11 Suspension.

Transmission Developer reserves the right, upon written notice to Connecting Transmission Owner and NYISO, to suspend at any time all work by Transmission Developer and Connecting Transmission Owner associated with the construction and installation of the Network Upgrade Facilities required for only that Transmission Developer under this Agreement

with the condition that the New York State Transmission System shall be left in a safe and reliable condition in accordance with Good Utility Practice and the safety and reliability criteria of Connecting Transmission Owner and NYISO. If the suspension will impact the Transmission Developer's ability to meet any Advisory Milestones or Critical Path Milestones in the Development Agreement, Transmission Developer shall notify the NYISO in accordance with the requirements in Article 3.3 of the Development Agreement. NYISO reserves the right, upon written notice to Transmission Developer and Connecting Transmission Owner, to require the suspension of all work by Transmission Developer and Connecting Transmission Owner associated with the engineering, procurement, and/or construction services under this Agreement if the NYISO terminates the Development Agreement pursuant to Article 8 of the Development Agreement.

In the event of suspension under this Article 5.11, Transmission Developer shall be responsible for all reasonable and necessary costs and/or obligations in accordance with the ISO OATT and the Facilities Study report including those which Connecting Transmission Owner (i) has incurred pursuant to this Agreement prior to the suspension and (ii) incurs in suspending such work, including any costs incurred to perform such work as may be necessary to ensure the safety of persons and property and the integrity of the New York State Transmission System during such suspension and, if applicable, any costs incurred in connection with the cancellation or suspension of material, equipment and labor contracts which Connecting Transmission Owner cannot reasonably avoid; provided, however, that prior to canceling or suspending any such material, equipment or labor contract, Connecting Transmission Owner shall obtain Transmission Developer's authorization to do so.

Connecting Transmission Owner shall invoice Transmission Developer for such costs pursuant to Article 12 and shall use due diligence to minimize its costs. In the event Transmission Developer suspends work by the Transmission Developer and Connecting Transmission Owner required under this Agreement pursuant to this Article 5.11, and has not informed the Parties that it is recommencing its work and requested Connecting Transmission Owner to recommence its work required under this Agreement on or before the expiration of three (3) years following commencement of such suspension, this Agreement shall be deemed terminated. The three-year period shall begin on the date of the written notice required under this Article 5.11 or the date specified in the written notice of suspension.

5.12 Taxes.

5.12.1 Transmission Developer Payments Taxable.

The Transmission Developer and Connecting Transmission Owner intend that all payments or property transfers made by Transmission Developer to Connecting Transmission Owner for the installation of the Network Upgrade Facilities shall be taxable as contributions in aid of construction.

5.12.2 Tax Gross-Up Amount.

Transmission Developer's liability for the cost consequences of any current tax liability under this Article 5.12 shall be calculated on a fully grossed-up basis. Except as may otherwise

be agreed to by the parties, this means that Transmission Developer will pay Connecting Transmission Owner, in addition to the amount paid for the Network Upgrade Facilities, an amount equal to (1) the current taxes imposed on Connecting Transmission Owner (“Current Taxes”) on the excess of (a) the gross income realized by Connecting Transmission Owner as a result of payments or property transfers made by Transmission Developer to Connecting Transmission Owner under this Agreement (without regard to any payments under this Article 5.12) (the “Gross Income Amount”) over (b) the present value of future tax deductions for depreciation that will be available as a result of such payments or property transfers (the “Present Value Depreciation Amount”), plus (2) an additional amount sufficient to permit the Connecting Transmission Owner to receive and retain, after the payment of all Current Taxes, an amount equal to the net amount described in clause (1).

For this purpose, (i) Current Taxes shall be computed based on Connecting Transmission Owner’s composite federal and state tax rates at the time the payments or property transfers are received and Connecting Transmission Owner will be treated as being subject to tax at the highest marginal rates in effect at that time (the “Current Tax Rate”), and (ii) the Present Value Depreciation Amount shall be computed by discounting Connecting Transmission Owner’s anticipated tax depreciation deductions as a result of such payments or property transfers by Connecting Transmission Owner’s current weighted average cost of capital. Thus, the formula for calculating Transmission Developer’s liability to Connecting Transmission Owner pursuant to this Article 5.12.2 can be expressed as follows: $(\text{Current Tax Rate} \times (\text{Gross Income Amount} - \text{Present Value Depreciation Amount})) / (1 - \text{Current Tax Rate})$. Transmission Developer’s estimated tax liability in the event taxes are imposed shall be stated in Appendix A, Network Upgrade Facilities.

5.12.3 Refund.

In the event (a) any legislative change or administrative announcement, notice, ruling or other determination makes it reasonably clear to Connecting Transmission Owner in good faith that any amount paid or the value of any property transferred by Transmission Developer to Connecting Transmission Owner under the terms of this Agreement is not taxable to Connecting Transmission Owner, (b) any abatement, appeal, protest, or other contest results in a determination that any payments or transfers made by Transmission Developer to Connecting Transmission Owner are not subject to federal income tax, or (c) if Connecting Transmission Owner receives a refund from any taxing authority for any overpayment of tax attributable to any payment or property transfer made by Transmission Developer to Connecting Transmission Owner pursuant to this Agreement, Connecting Transmission Owner shall promptly refund to Transmission Developer the following:

- (i) Any payment made by Transmission Developer under this Article 5.12 for taxes that is attributable to the amount determined to be taxable, together with interest thereon,
- (ii) Interest on any amounts paid by Transmission Developer to Connecting Transmission Owner for such taxes which Connecting Transmission Owner did not submit to the taxing authority, calculated in accordance with the methodology set forth in FERC’s regulations

at 18 C.F.R. §35.19a(a)(2)(iii) from the date payment was made by Transmission Developer to the date Connecting Transmission Owner refunds such payment to Transmission Developer, and

(iii) With respect to any such taxes paid by Connecting Transmission Owner, any refund or credit Connecting Transmission Owner receives or to which it may be entitled from any Governmental Authority, interest (or that portion thereof attributable to the payment described in clause (i), above) owed to the Connecting Transmission Owner for such overpayment of taxes (including any reduction in interest otherwise payable by Connecting Transmission Owner to any Governmental Authority resulting from an offset or credit); provided, however, that Connecting Transmission Owner will remit such amount promptly to Transmission Developer only after and to the extent that Connecting Transmission Owner has received a tax refund, credit or offset from any Governmental Authority for any applicable overpayment of income tax related to the Network Upgrade Facilities.

The intent of this provision is to leave both the Transmission Developer and Connecting Transmission Owner, to the extent practicable, in the event that no taxes are due with respect to any payment for Network Upgrade Facilities hereunder, in the same position they would have been in had no such tax payments been made.

5.12.4 Taxes Other Than Income Taxes.

Upon the timely request by Transmission Developer, and at Transmission Developer's sole expense, Connecting Transmission Owner shall appeal, protest, seek abatement of, or otherwise contest any tax (other than federal or state income tax) asserted or assessed against Connecting Transmission Owner for which Transmission Developer may be required to reimburse Connecting Transmission Owner under the terms of this Agreement. Transmission Developer shall pay to Connecting Transmission Owner on a periodic basis, as invoiced by Connecting Transmission Owner, Connecting Transmission Owner's documented reasonable costs of prosecuting such appeal, protest, abatement, or other contest. Transmission Developer and Connecting Transmission Owner shall cooperate in good faith with respect to any such contest. Unless the payment of such taxes is a prerequisite to an appeal or abatement or cannot be deferred, no amount shall be payable by Transmission Developer to Connecting Transmission Owner for such taxes until they are assessed by a final, non-appealable order by any court or agency of competent jurisdiction. In the event that a tax payment is withheld and ultimately due and payable after appeal, Transmission Developer will be responsible for all taxes, interest and penalties, other than penalties attributable to any delay caused by Connecting Transmission Owner.

5.13 Tax Status; Non-Jurisdictional Entities.

5.13.1 Tax Status.

Each Party shall cooperate with the other Parties to maintain the other Parties' tax status. Nothing in this Agreement is intended to adversely affect the tax status of any Party including the status of NYISO, or the status of any Connecting Transmission Owner with respect to the issuance of bonds including, but not limited to, Local Furnishing Bonds.

5.14 Modification.

5.14.1 General.

If, prior to the In-Service Date of the Transmission Project or Network Upgrade Facilities, either the Transmission Developer or Connecting Transmission Owner proposes to modify the Transmission Project or Network Upgrade Facilities, they must inform the other Parties of the proposed modification and must satisfy the requirements for such modifications in (i) Section 22.5.4 of Attachment P to the NYISO OATT, and (ii) the Development Agreement. The Transmission Developer shall be responsible for the cost of any such additional modifications, including the cost of studying the materiality and impact of the modification.

Following the In-Service Date of the Transmission Project or Network Upgrade Facilities, either the Transmission Developer or Connecting Transmission Owner may undertake modifications to its facilities covered by this Agreement. If either the Transmission Developer or Connecting Transmission Owner plans to undertake a modification that reasonably may be expected to affect the other Party's facilities, that Party shall provide to the other Party, and to NYISO, sufficient information regarding such modification so that the other Party and NYISO may evaluate the potential impact of such modification prior to commencement of the work. Such information shall be deemed to be Confidential Information hereunder and shall include information concerning the timing of such modifications and whether such modifications are expected to interrupt the transmission of electricity at the Point(s) of Interconnection. The Party desiring to perform such work shall provide the relevant drawings, plans, and specifications to the other Party and NYISO at least ninety (90) Calendar Days in advance of the commencement of construction regarding such work or such shorter period upon which the Parties may agree, which agreement shall not unreasonably be withheld, conditioned or delayed.

5.14.2 Standards.

Any additions, modifications, or replacements made to a Party's facilities shall be designed, constructed and operated in accordance with this Agreement, NYISO requirements and Good Utility Practice.

5.14.3 Modification Costs.

Transmission Developer or Connecting Transmission Owner, as applicable, shall not be assigned the costs of any additions, modifications, or replacements that the other Party makes to the New York State Transmission System to facilitate the interconnection of a third party to the New York State Transmission System, or to provide Transmission Service to a third party under the ISO OATT, except in accordance with the cost allocation procedures in Attachment S of the ISO OATT.

ARTICLE 6. TESTING AND INSPECTION

6.1 Pre-In Service Date Testing and Modifications.

Prior to the In-Service Date of the Transmission Project or Network Upgrade Facilities, as applicable, the Connecting Transmission Owner shall test the Network Upgrade Facilities and Transmission Developer shall test the Transmission Project to ensure their safe and reliable operation. Similar testing may be required after initial operation. Transmission Developer and Connecting Transmission Owner shall each make any modifications to its facilities that are found to be necessary as a result of such testing. Transmission Developer shall bear the cost of all such testing and modifications. Transmission Developer and Connecting Transmission Owner shall coordinate with NYISO prior to performing the testing of the Transmission Project and Network Upgrade Facilities and prior to the facilities entering into service.

6.2 Post-In-Service Date Testing and Modifications.

Transmission Developer and Connecting Transmission Owner shall each at its own expense perform routine inspection and testing of its facilities and equipment in accordance with Good Utility Practice and Applicable Reliability Standards as may be necessary to ensure the continued interconnection of the Transmission Project with the New York State Transmission System in a safe and reliable manner. Transmission Developer and Connecting Transmission Owner shall each have the right, upon advance written notice, to require reasonable additional testing of the other Party's facilities, at the requesting Party's expense, as may be in accordance with Good Utility Practice.

6.3 Right to Observe Testing.

Transmission Developer and Connecting Transmission Owner shall each notify the other Party, and the NYISO, in advance of its performance of tests of the Transmission Project and Network Upgrade Facilities. The other Party, and the NYISO, shall each have the right, at its own expense, to observe such testing.

6.4 Right to Inspect.

Transmission Developer and Connecting Transmission Owner shall each have the right, but shall have no obligation to: (i) observe the other Party's tests and/or inspection of any of its System Protection Facilities and other protective equipment; (ii) review the settings of the other Party's System Protection Facilities and other protective equipment; and (iii) review the other Party's maintenance records relative to the System Protection Facilities and other protective equipment. NYISO shall have these same rights of inspection as to the facilities and equipment of Transmission Developer and Connecting Transmission Owner. A Party may exercise these rights from time to time as it deems necessary upon reasonable notice to the other Party. The exercise or non-exercise by a Party of any such rights shall not be construed as an endorsement or confirmation of any element or condition of the System Protection Facilities or other protective equipment or the operation thereof, or as a warranty as to the fitness, safety, desirability, or reliability of same. Any information that a Party obtains through the exercise of any of its rights under this Article 6.4 shall be treated in accordance with Article 22 of this Agreement and Attachment F to the ISO OATT.

ARTICLE 7. METERING

7.1 General.

Transmission Developer shall procure and install Metering Equipment at any Metering Points identified by the NYISO prior to any operation of the Transmission Project. Transmission Developer shall own, operate, test, maintain, and, if directed by the NYISO, relocate such Metering Equipment in accordance with ISO Procedures, as such requirements are amended from time to time. Transmission Developer shall provide the NYISO and Connecting Transmission Owner, as applicable, with metering data in accordance with the metering requirements set forth in this Agreement, the Operating Agreement (including Section 2.05, *Local Control Center, Metering and Telemetry*), the NYISO Tariffs, and ISO Procedures, as such requirements are amended from time to time. Transmission Developer shall bear all reasonable documented costs associated with the purchase, installation, operation, testing and maintenance of the Metering Equipment.

7.2 Check Meters.

Connecting Transmission Owner, at its option and expense, may install and operate, on its premises and on its side of the Points of Interconnection, one or more check meters to check Transmission Developer's meters. Such check meters shall be for check purposes only and shall not be used for the measurement of power flows for purposes of this Agreement, except as provided in Article 7.4 below. The installation, operation and maintenance thereof shall be performed entirely by Connecting Transmission Owner in accordance with Good Utility Practice.

7.3 Standards.

Transmission Developer shall install, calibrate, and test revenue quality Metering Equipment including potential transformers and current transformers in accordance with ISO Procedures, as such requirements are amended from time to time.

7.4 Testing of Metering Equipment.

Transmission Developer shall inspect and test all of its Metering Equipment upon installation and at least once every two (2) years thereafter. If required by ISO Procedures, Transmission Developer shall, at its own expense, inspect or test Metering Equipment more frequently than every two (2) years. Transmission Developer shall give reasonable notice of the time when any inspection or test shall take place, and NYISO may have representatives present at the test or inspection. If at any time Metering Equipment is found to be inaccurate or defective, it shall be adjusted, repaired or replaced at Transmission Developer's expense in order to provide accurate metering. Transmission Developer and NYISO shall address the loss of meter data or meter data anomalies in accordance with ISO Procedures. The NYISO shall reserve the right to review all associated metering equipment installation on the Transmission Developer's or Connecting Transmission Owner's property at any time.

7.5 Metering Data.

At Transmission Developer's expense, the metered data shall be telemetered to one or more locations designated by NYISO. Such telemetered data shall be used, under normal operating conditions, as the official measurement of the amount of energy at the Metering Points.

ARTICLE 8. COMMUNICATIONS

8.1 Transmission Developer Obligations.

Transmission Developer shall maintain satisfactory operating communications, including providing analog and digital real-time telemetry, with Connecting Transmission Owner and NYISO in accordance with the requirements in this Agreement, the Operating Agreement (including Section 2.05, *Local Control Center, Metering and Telemetry*), NYISO Tariffs, and ISO Procedures, as such requirements are amended from time to time. Transmission Developer shall provide standard voice line, dedicated voice line and facsimile communications at its control center for the Transmission Project through use of either the public telephone system, or a voice communications system that does not rely on the public telephone system. Transmission Developer shall also provide the dedicated data circuit(s) necessary to provide Transmission Developer data to Connecting Transmission Owner and NYISO as set forth in Appendix D hereto. The data circuit(s) shall extend from the Transmission Project to the location(s) specified by Connecting Transmission Owner and NYISO. Any required maintenance of such communications equipment shall be performed by Transmission Developer. Operational communications shall be activated and maintained under, but not be limited to, the following events: system paralleling or separation, scheduled and unscheduled shutdowns, equipment clearances, and hourly and daily load data.

8.2 Remote Terminal Unit.

Prior to the Initial Synchronization Date of the Transmission Project, a Remote Terminal Unit, or equivalent data collection and transfer equipment acceptable to the Parties, shall be installed by Transmission Developer, or by Connecting Transmission Owner at Transmission Developer's expense, to gather accumulated and instantaneous data to be telemetered to the location(s) designated by Connecting Transmission Owner and NYISO through use of a dedicated point-to-point data circuit(s) as indicated in Article 8.1. The communication protocol for the data circuit(s) shall be specified by Connecting Transmission Owner and NYISO. Instantaneous bi-directional analog real power and reactive power flow information must be telemetered directly to the location(s) specified by Connecting Transmission Owner and NYISO.

Each Party will promptly advise the appropriate other Party if it detects or otherwise learns of any metering, telemetry or communications equipment errors or malfunctions that require the attention and/or correction by that other Party. The Party owning such equipment shall correct such error or malfunction as soon as reasonably feasible.

8.3 No Annexation.

Any and all equipment placed on the premises of a Party shall be and remain the property of the Party providing such equipment regardless of the mode and manner of annexation or

attachment to real property, unless otherwise mutually agreed by the Party providing such equipment and the Party receiving such equipment.

ARTICLE 9. OPERATIONS

9.1 General.

Each Party shall comply with Applicable Laws and Regulations and Applicable Reliability Standards. Each Party shall provide to the other Parties all information that may reasonably be required by the other Parties to comply with Applicable Laws and Regulations and Applicable Reliability Standards. Connecting Transmission Owner or Transmission Developer, as applicable, shall provide the NYISO with notifications of all of its power system equipment additions or modifications in accordance with ISO Procedures, including the NYISO's Reliability Analysis Data Manual (Manual 24).

9.2 NYISO and Connecting Transmission Owner Obligations.

Connecting Transmission Owner and NYISO shall cause the New York State Transmission System to be operated, maintained and controlled in a safe and reliable manner in accordance with this Agreement and the NYISO Tariffs. Connecting Transmission Owner and NYISO may provide operating instructions to Transmission Developer consistent with this Agreement, NYISO procedures and Connecting Transmission Owner's operating protocols and procedures as they may change from time to time. Connecting Transmission Owner and NYISO will consider changes to their respective operating protocols and procedures proposed by Transmission Developer.

9.3 Transmission Developer Obligations.

Transmission Developer shall at its own expense operate, maintain and control the Transmission Project and the Network Upgrade Facilities specified in Appendix C in a safe and reliable manner and in accordance with this Agreement, the NYISO Tariffs, ISO Procedures, and the Operating Agreement. Transmission Developer shall operate the Transmission Project and the Network Upgrade Facilities specified in Appendix C in accordance with NYISO and Connecting Transmission Owner requirements, as such requirements are set forth or referenced in Appendix C hereto. Appendix C will be modified to reflect changes to the requirements as they may change from time to time. Any Party may request that the appropriate other Party or Parties provide copies of the requirements set forth or referenced in Appendix C hereto.

9.4 Reserved.

9.5 Outages and Interruptions.

9.5.1 Outages.

9.5.1.1 Outage Authority and Coordination.

Transmission Developer and Connecting Transmission Owner may each, in accordance with NYISO procedures and Good Utility Practice and in coordination with the other Party,

remove from service any of its respective Transmission Project facilities or Network Upgrade Facilities that may impact the other Party's facilities as necessary to perform maintenance or testing or to install or replace equipment. Absent an Emergency or Emergency State, the Party scheduling a removal of such facility(ies) from service will use Reasonable Efforts to schedule such removal on a date and time mutually acceptable to both the Transmission Developer and the Connecting Transmission Owner. In all circumstances either Party planning to remove such facility(ies) from service shall use Reasonable Efforts to minimize the effect on the other Party of such removal.

9.5.1.2 Outage Schedules.

The Transmission Developer or Connecting Transmission Owner, as applicable and pursuant to ISO Procedures, shall post scheduled outages of its respective transmission facilities on the NYISO OASIS.

9.5.1.3 Outage Restoration.

If an outage on the Transmission Project or Network Upgrade Facilities adversely affects the other Party's operations or facilities, the Party that owns the facility that is out of service shall use Reasonable Efforts to promptly restore such facility(ies) to a normal operating condition consistent with the nature of the outage. The Party that owns the facility that is out of service shall provide the other Party and NYISO, to the extent such information is known, information on the nature of the Emergency or Emergency State, an estimated time of restoration, and any corrective actions required. Initial verbal notice shall be followed up as soon as practicable with written notice explaining the nature of the outage.

9.5.2 Interruption of Service. If required by Good Utility Practice or Applicable Reliability Standards to do so, the NYISO, Connecting Transmission Owner, or Transmission Developer may require the Connecting Transmission Owner or Transmission Developer to interrupt the transmission of electricity if such transmission of electricity could adversely affect the ability of NYISO and, as applicable, Connecting Transmission Owner or Transmission Developer to perform such activities as are necessary to safely and reliably operate and maintain the New York State Transmission System. The following provisions shall apply to any interruption permitted under this Article 9.5.2:

9.5.2.1 The interruption or reduction shall continue only for so long as reasonably necessary under Good Utility Practice;

9.5.2.2 When the interruption or reduction must be made under circumstances which do not allow for advance notice, NYISO, Connecting Transmission Owner, or Transmission Developer shall notify, as applicable, Transmission Developer or Connecting Transmission Owner by telephone as soon as practicable of the reasons for the curtailment or interruption, and, if known, its expected duration. Telephone notification shall be followed by written notification as soon as practicable;

9.5.2.3 Except during the existence of an Emergency or Emergency State, when the interruption can be scheduled without advance notice, NYISO, Connecting Transmission

Owner, or Transmission Developer shall notify, as applicable, Transmission Developer or Connecting Transmission Owner in advance regarding the timing of such scheduling and of the expected duration. The Parties shall coordinate with each other using Good Utility Practice to schedule the interruption during periods of least impact to Transmission Developer, the Connecting Transmission Owner and the New York State Transmission System;

9.5.2.4 The Parties shall cooperate and coordinate with each other to the extent necessary in order to restore the Transmission Project, Network Upgrade Facilities, and the New York State Transmission System to their normal operating state, consistent with system conditions and Good Utility Practice.

9.5.3 System Protection and Other Control Requirements.

9.5.3.1 System Protection Facilities. Transmission Developer shall, at its expense, install, operate and maintain System Protection Facilities as a part of the Transmission Project. Connecting Transmission Owner shall install at Transmission Developer's expense any System Protection Facilities that may be required on the New York State Transmission System as a result of the interconnection of the Transmission Project.

9.5.3.2 The protection facilities of both the Transmission Developer and Connecting Transmission Owner shall be designed and coordinated with other systems in accordance with Good Utility Practice and Applicable Reliability Standards.

9.5.3.3 The Transmission Developer and Connecting Transmission Owner shall each be responsible for protection of its respective facilities consistent with Good Utility Practice and Applicable Reliability Standards.

9.5.3.4 The protective relay design of the Transmission Developer and Connecting Transmission Owner shall each incorporate the necessary test switches to perform the tests required in Article 6 of this Agreement. The required test switches will be placed such that they allow operation of lockout relays while preventing breaker failure schemes from operating and causing unnecessary breaker operations and/or the tripping of the Transmission Developer's Transmission Project.

9.5.3.5 The Transmission Developer and Connecting Transmission Owner will each test, operate and maintain System Protection Facilities in accordance with Good Utility Practice, NERC and NPCC criteria.

9.5.3.6 Prior to the In-Service Dates of the Transmission Project and Network Upgrade Facilities, as applicable, the Transmission Developer and Connecting Transmission Owner shall each perform, or their agents shall perform, a complete calibration test and functional trip test of the System Protection Facilities. At intervals suggested by Good Utility Practice and following any apparent malfunction of the System Protection Facilities, the Transmission Developer and Connecting Transmission Owner shall each perform both calibration and functional trip tests of its System Protection Facilities. These tests do not require the tripping of any in-service generation unit. These tests do, however, require that all protective relays and lockout contacts be activated.

9.5.4 Requirements for Protection.

In compliance with NPCC requirements and Good Utility Practice, Transmission Developer shall provide, install, own, and maintain relays, circuit breakers and all other devices necessary to remove any fault contribution of the Transmission Project to any short circuit occurring on the New York State Transmission System not otherwise isolated by Connecting Transmission Owner's equipment, such that the removal of the fault contribution shall be coordinated with the protective requirements of the New York State Transmission System. Such protective equipment shall include, without limitation, a disconnecting device or switch with load-interrupting capability located between the Transmission Project and the New York State Transmission System at a site selected upon mutual agreement (not to be unreasonably withheld, conditioned or delayed) of the Transmission Developer and Connecting Transmission Owner. Transmission Developer shall be responsible for protection of the Transmission Project and Transmission Developer's other equipment from such conditions as negative sequence currents, over- or under-frequency, sudden load rejection, over- or under-voltage, and generator loss-of-field. Transmission Developer shall be solely responsible to disconnect the Transmission Project and Transmission Developer's other equipment if conditions on the New York State Transmission System could adversely affect the Transmission Project.

9.5.5 Power Quality.

Neither the facilities of Transmission Developer nor the facilities of Connecting Transmission Owner shall cause excessive voltage flicker nor introduce excessive distortion to the sinusoidal voltage or current waves as defined by ANSI Standard C84.1-1989, in accordance with IEEE Standard 519, or any applicable superseding electric industry standard. In the event of a conflict between ANSI Standard C84.1-1989, or any applicable superseding electric industry standard, ANSI Standard C84.1-1989, or the applicable superseding electric industry standard, shall control.

9.6 Switching and Tagging Rules.

The Transmission Developer and Connecting Transmission Owner shall each provide the other Party a copy of its switching and tagging rules that are applicable to the other Party's activities. Such switching and tagging rules shall be developed on a nondiscriminatory basis. The Parties shall comply with applicable switching and tagging rules, as amended from time to time, in obtaining clearances for work or for switching operations on equipment.

9.7 Disturbance Analysis Data Exchange.

The Parties will cooperate with one another and the NYISO in the analysis of disturbances to either the Transmission Project or the New York State Transmission System by gathering and providing access to any information relating to any disturbance, including information from disturbance recording equipment, protective relay targets, breaker operations and sequence of events records, and any disturbance information required by Good Utility Practice.

ARTICLE 10. MAINTENANCE

10.1 Connecting Transmission Owner Obligations.

Connecting Transmission Owner shall maintain its transmission facilities, including the Network Upgrade Facilities it owns as specified in Appendix C, in a safe and reliable manner and in accordance with this Agreement.

10.2 Transmission Developer Obligations.

Transmission Developer shall maintain its Transmission Project and the Network Upgrade Facilities it owns as specified in Appendix C in a safe and reliable manner and in accordance with this Agreement.

10.3 Coordination.

The Transmission Developer and Connecting Transmission Owner shall confer regularly to coordinate the planning, scheduling and performance of preventive and corrective maintenance on the Transmission Project and Network Upgrade Facilities. The Transmission Developer and Connecting Transmission Owner shall keep NYISO fully informed of the preventive and corrective maintenance that is planned, and shall schedule all such maintenance, in accordance with NYISO procedures.

10.4 Secondary Systems.

The Transmission Developer and Connecting Transmission Owner shall each cooperate with the other in the inspection, maintenance, and testing of control or power circuits that operate below 600 volts, AC or DC, including, but not limited to, any hardware, control or protective devices, cables, conductors, electric raceways, secondary equipment panels, transducers, batteries, chargers, and voltage and current transformers that directly affect the operation of Transmission Developer or Connecting Transmission Owner's facilities and equipment which may reasonably be expected to impact the other Party. The Transmission Developer and Connecting Transmission Owner shall each provide advance notice to the other Party, and to NYISO, before undertaking any work on such circuits, especially on electrical circuits involving circuit breaker trip and close contacts, current transformers, or potential transformers.

10.5 Operating and Maintenance Expenses.

Subject to the provisions herein addressing the use of facilities by others, and except for operations and maintenance expenses associated with modifications made for providing interconnection or transmission service to a third party and such third party pays for such expenses, Transmission Developer shall be responsible for all reasonable expenses including overheads, associated with owning, operating, maintaining, repairing, and replacing the Transmission Project and the Network Upgrade Facilities it owns as specified in Appendix C. The Connecting Transmission Owner shall be responsible for all reasonable expenses including overheads, associated with owning, operating, maintaining, repairing, and replacing the Network Upgrade Facilities it owns as specified in Appendix C.

ARTICLE 11. PERFORMANCE OBLIGATION

11.1 Transmission Project.

Transmission Developer shall design, procure, construct, install, own and/or control the Transmission Project described in Appendix C hereto, at its sole expense.

11.2 Network Upgrade Facilities.

Transmission Developer shall design, procure, construct, and install the Network Upgrade Facilities as specified in Appendix A hereto. Connecting Transmission Owner or Transmission Developer, as applicable, shall own, operate, maintain, and control the Network Upgrade Facilities as specified in Appendix C.

11.3 Reserved.

11.4 Provision of Security.

Within thirty (30) Calendar Days of the Effective Date of this Agreement, Transmission Developer shall provide Connecting Transmission Owner with Security for the Network Upgrade Facilities in the amount set forth in Appendix A of this Agreement. If the Transmission Developer: (i) does not pay an invoice issued by the Connecting Transmission Owner pursuant to Article 12.1 within the timeframe set forth in Article 12.3 or (ii) does not pay any disputed amount into an independent escrow account pursuant to Article 12.4, the Connecting Transmission Owner may draw upon Transmission Developer's Security to recover such payment. The Security shall be reduced on a dollar-for-dollar basis for payments made to Connecting Transmission Owner for the purpose of constructing, procuring, and installing the Network Upgrade Facilities.

In addition:

11.4.1 The guarantee must be made by an entity that meets the commercially reasonable creditworthiness requirements of Connecting Transmission Owner, and contains terms and conditions that guarantee payment of the Security amount set forth in Appendix A of this Agreement.

11.4.2 The letter of credit must be issued by a financial institution reasonably acceptable to Connecting Transmission Owner and must specify a reasonable expiration date.

11.4.3 The surety bond must be issued by an insurer reasonably acceptable to Connecting Transmission Owner and must specify a reasonable expiration date.

11.5 Forfeiture of Security.

The Security that the Transmission Developer provides the Connecting Transmission Owner in accordance with Article 11.4 of this Agreement shall be irrevocable and shall be subject to forfeiture in the event that the Transmission Developer subsequently terminates or abandons development of the Transmission Project. Any Security provided by the Transmission

Developer to the Connecting Transmission Owner shall be subject to forfeiture to the extent necessary to defray the cost of: (1) Network Upgrade Facilities required for other Transmission Developers whose Transmission Project interconnection studies included the Transmission Developer's Transmission Project and Network Upgrade Facilities in their base cases; and (2) System Upgrade Facilities and System Deliverability Upgrade Facilities required for projects for which the Transmission Project and Network Upgrade Facilities were included in their Annual Transmission Reliability Assessment and/or Class Year Deliverability Study, as applicable. If Transmission Developer's Security is subject to forfeiture to defray the costs of an affected upgrade pursuant to this Article 11.5 and the Security is not in a form that can be readily drawn on by the Connecting Transmission Owner to defray the costs of the affected upgrade, Transmission Developer shall negotiate in good faith with the Connecting Transmission Owner to replace the Security with cash or an alternative form of Security that can be readily drawn on by Connecting Transmission Owner up to the amount required to satisfy Transmission Developer's Security obligations under this Agreement, including defraying the costs of the affected upgrade. Connecting Transmission Owner shall only be responsible for using Transmission Developer's Security to defray the costs of an affected upgrade to the extent Transmission Developer has provided cash or Security in a form that the Connecting Transmission Owner can readily draw on to defray such costs.

11.6 Network Upgrade Facility Costs

11.6.1 If the actual cost of Network Upgrade Facilities is less than the NUF Estimated Total Costs amount, Transmission Developer is responsible only for the actual cost figure.

11.6.2 If the actual cost of Network Upgrade Facilities is greater than the NUF Estimated Total Costs amount because other projects have been expanded, accelerated, otherwise modified or terminated, Transmission Developer is responsible only for the agreed-to and secured amount for the Network Upgrade Facilities. The additional cost is covered by the developers of the modified projects, or by the drawing on the cash that has been paid and the Security that has been posted for terminated projects, depending on the factors that caused the additional cost. Such forfeitable Security from other developers will be drawn on only as needed for this purpose, and only to the extent that the terminated project associated with that Security has caused additional cost and that the developer of the terminated project has provided cash or Security in a form that the Connecting Transmission Owner can readily draw on.

11.6.3 If the actual cost of the Network Upgrade Facilities is greater than the NUF Estimated Total Costs amount for reasons other than those set forth in Article 11.6.2, Transmission Developer will pay the additional costs to Connecting Transmission Owner to the extent such costs are prudently incurred. Disputes between Transmission Developer and Connecting Transmission Owner concerning costs in excess of the agreed-to and secured amount will be resolved by the parties in accordance with the terms and conditions of Article 27.

11.7 Line Outage Costs.

Notwithstanding anything in the ISO OATT to the contrary, the Connecting Transmission Owner may propose to recover line outage costs associated with the installation of Network Upgrade Facilities on a case-by-case basis.

ARTICLE 12. INVOICE

12.1 General.

The Transmission Developer and Connecting Transmission Owner shall each submit to the other Party, on a monthly basis, invoices of amounts due for the preceding month. Each invoice shall state the month to which the invoice applies and fully describe the services and equipment provided. The Transmission Developer and Connecting Transmission Owner may discharge mutual debts and payment obligations due and owing to each other on the same date through netting, in which case all amounts one Party owes to the other Party under this Agreement, including interest payments or credits, shall be netted so that only the net amount remaining due shall be paid by the owing Party.

12.2 Final Invoice and Refund of Remaining Security.

Within six months after completion of the construction of Network Upgrade Facilities, Connecting Transmission Owner shall provide an invoice of the final cost of the construction of the Network Upgrade Facilities and shall set forth such costs in sufficient detail to enable Transmission Developer to compare the actual costs with the estimates and to ascertain deviations, if any, from the cost estimates. Connecting Transmission Owner shall refund to Transmission Developer any amount by which the actual payment by Transmission Developer for estimated costs exceeds the actual costs of construction within thirty (30) Calendar Days of the issuance of such final construction invoice. Following the later of the completion of the construction of the Network Upgrade Facilities and Transmission Developer's payment of any final invoice issued under this Article 12.2, Connecting Transmission Owner shall refund to the Transmission Developer any remaining portions of its Security, except as set forth in Article 11.5. Connecting Transmission Owner shall provide Transmission Developer with the refunded amount within thirty (30) Calendar Days of the Parties' satisfaction of the requirements in this Article 12.2.

12.3 Payment.

Invoices shall be rendered to the paying Party at the address specified in Appendix F hereto. The Party receiving the invoice shall pay the invoice within thirty (30) Calendar Days of receipt. All payments shall be made in immediately available funds payable to the other Party, or by wire transfer to a bank named and account designated by the invoicing Party. Payment of invoices will not constitute a waiver of any rights or claims the paying Party may have under this Agreement.

12.4 Disputes.

In the event of a billing dispute between Connecting Transmission Owner and Transmission Developer, Connecting Transmission Owner shall continue to perform under this Agreement as long as Transmission Developer: (i) continues to make all payments not in dispute; and (ii) pays to Connecting Transmission Owner or into an independent escrow account the portion of the invoice in dispute, pending resolution of such dispute. If Transmission Developer fails to meet these two requirements for continuation of service, then Connecting Transmission Owner may provide notice to Transmission Developer of a Default pursuant to Article 17.

Within thirty (30) Calendar Days after the resolution of the dispute, the Party that owes money to the other Party shall pay the amount due with interest calculated in accord with the methodology set forth in FERC's Regulations at 18 C.F.R. § 35.19a(a)(2)(iii).

ARTICLE 13. EMERGENCIES

13.1 Obligations.

Each Party shall comply with the Emergency State procedures of NYISO, the applicable Reliability Councils, Applicable Laws and Regulations, and any emergency procedures agreed to by the NYISO Operating Committee. Transmission Developer and Connecting Transmission Owner agree to coordinate with NYISO to develop procedures that will address the operations of the Transmission Project during Emergency conditions.

13.2 Notice.

Each Party shall notify the other Parties promptly when it becomes aware of an Emergency or Emergency State that affects, or may reasonably be expected to affect, the Transmission Project or the New York State Transmission System. To the extent information is known, the notification shall describe the Emergency or Emergency State, the extent of the damage or deficiency, the expected effect on the operation of Transmission Developer's or Connecting Transmission Owner's facilities and operations, its anticipated duration and the corrective action taken and/or to be taken. The initial notice shall be followed as soon as practicable with written notice.

13.3 Immediate Action.

Unless, in Transmission Developer's reasonable judgment, immediate action is required, Transmission Developer shall obtain the consent of Connecting Transmission Owner, such consent to not be unreasonably withheld, prior to performing any manual switching operations at the Transmission Project in response to an Emergency or Emergency State either declared by NYISO, Connecting Transmission Owner or otherwise regarding New York State Transmission System.

13.4 NYISO, Transmission Developer, and Connecting Transmission Owner Authority.

Consistent with ISO Procedures, Good Utility Practice, and this Agreement, any Party may take whatever actions with regard to the New York State Transmission System it deems necessary during an Emergency or Emergency State in order to (i) preserve public health and safety, (ii) preserve the reliability of the New York State Transmission System, (iii) limit or prevent damage, and (iv) expedite restoration of service. Transmission Developer and Connecting Transmission Owner shall use Reasonable Efforts to assist the other in such actions.

13.5 Limited Liability.

No Party shall be liable to another Party for any action it takes in responding to an Emergency or Emergency State so long as such action is made in good faith and is consistent with Good Utility Practice and the NYISO Tariffs.

ARTICLE 14. REGULATORY REQUIREMENTS AND GOVERNING LAW

14.1 Regulatory Requirements.

Each Party's obligations under this Agreement shall be subject to its receipt of any required approval or certificate from one or more Governmental Authorities in the form and substance satisfactory to the applying Party, or the Party making any required filings with, or providing notice to, such Governmental Authorities, and the expiration of any time period associated therewith. Each Party shall in good faith seek and use its Reasonable Efforts to obtain such other approvals. Nothing in this Agreement shall require Transmission Developer to take any action that could result in its inability to obtain, or its loss of, status or exemption under the Federal Power Act or the Public Utility Holding Company Act of 2005 or the Public Utility Regulatory Policies Act of 1978, as amended.

14.2 Governing Law.

14.2.1 The validity, interpretation and performance of this Agreement and each of its provisions shall be governed by the laws of the state of New York, without regard to its conflicts of law principles.

14.2.2 This Agreement is subject to all Applicable Laws and Regulations.

14.2.3 Each Party expressly reserves the right to seek changes in, appeal, or otherwise contest any laws, orders, rules, or regulations of a Governmental Authority.

ARTICLE 15. NOTICES

15.1 General.

Unless otherwise provided in this Agreement, any notice, demand or request required or permitted to be given by a Party to the other Parties and any instrument required or permitted to be tendered or delivered by a Party in writing to the other Parties shall be effective when delivered and may be so given, tendered or delivered, by recognized national courier, or by depositing the same with the United States Postal Service with postage prepaid, for delivery by certified or registered mail, addressed to the Party, or personally delivered to the Party, at the address set out in Appendix F hereto.

A Party may change the notice information in this Agreement by giving five (5) Business Days written notice prior to the effective date of the change.

15.2 Billings and Payments.

Billings and payments shall be sent to the addresses set out in Appendix F hereto.

15.3 Alternative Forms of Notice.

Any notice or request required or permitted to be given by a Party to the other Parties and not required by this Agreement to be given in writing may be so given by telephone, facsimile or email to the telephone numbers and email addresses set out in Appendix F hereto.

15.4 Operations and Maintenance Notice.

Transmission Developer and Connecting Transmission Owner shall each notify the other Party, and NYISO, in writing of the identity of the person(s) that it designates as the point(s) of contact with respect to the implementation of Articles 9 and 10 of this Agreement.

ARTICLE 16. FORCE MAJEURE

16.1 Economic hardship is not considered a Force Majeure event.

16.2 A Party shall not be responsible or liable, or deemed, in Default with respect to any obligation hereunder, other than the obligation to pay money when due, to the extent the Party is prevented from fulfilling such obligation by Force Majeure. A Party unable to fulfill any obligation hereunder (other than an obligation to pay money when due) by reason of Force Majeure shall give notice and the full particulars of such Force Majeure to the other Parties in writing or by telephone as soon as reasonably possible after the occurrence of the cause relied upon. Telephone notices given pursuant to this Article shall be confirmed in writing as soon as reasonably possible and shall specifically state full particulars of the Force Majeure, the time and date when the Force Majeure occurred and when the Force Majeure is reasonably expected to cease. The Party affected shall exercise due diligence to remove such disability with reasonable dispatch, but shall not be required to accede or agree to any provision not satisfactory to it in order to settle and terminate a strike or other labor disturbance.

ARTICLE 17. DEFAULT

17.1 General.

No Breach shall exist where such failure to discharge an obligation (other than the payment of money) is the result of Force Majeure as defined in this Agreement or the result of an act or omission of the other Parties. Upon a Breach, the non-Breaching Parties shall give written notice of such to the Breaching Party. The Breaching Party shall have thirty (30) Calendar Days from receipt of the Breach notice within which to cure such Breach; provided however, if such Breach is not capable of cure within thirty (30) Calendar Days, the Breaching Party shall commence such cure within thirty (30) Calendar Days after notice and continuously and diligently complete such cure within ninety (90) Calendar Days from receipt of the Breach notice; and, if cured within such time, the Breach specified in such notice shall cease to exist.

17.2 Right to Terminate.

If a Breach is not cured as provided in this Article 17, or if a Breach is not capable of being cured within the period provided for herein, the non-Breaching Parties acting together shall thereafter have the right to declare a Default and terminate this Agreement by written notice at any time until cure occurs, and be relieved of any further obligation hereunder and, whether or not those Parties terminate this Agreement, to recover from the defaulting Party all amounts due hereunder, plus all other damages and remedies to which they are entitled at law or in equity. The provisions of this Article will survive termination of this Agreement.

ARTICLE 18. INDEMNITY, CONSEQUENTIAL DAMAGES AND INSURANCE

18.1 Indemnity.

Each Party (the “Indemnifying Party”) shall at all times indemnify, defend, and save harmless, as applicable, the other Parties (each an “Indemnified Party”) from, any and all damages, losses, claims, including claims and actions relating to injury to or death of any person or damage to property, the alleged violation of any Environmental Law, or the release or threatened release of any Hazardous Substance, demand, suits, recoveries, costs and expenses, court costs, attorney fees, and all other obligations by or to third parties (any and all of these a “Loss”), arising out of or resulting from (i) the Indemnified Party’s performance of its obligations under this Agreement on behalf of the Indemnifying Party, except in cases where the Indemnifying Party can demonstrate that the Loss of the Indemnified Party was caused by the gross negligence or intentional wrongdoing of the Indemnified Party or (ii) the violation by the Indemnifying Party of any Environmental Law or the release by the Indemnifying Party of any Hazardous Substance.

18.1.1 Indemnified Party.

If a Party is entitled to indemnification under this Article 18 as a result of a claim by a third party, and the Indemnifying Party fails, after notice and reasonable opportunity to proceed under Article 18.1.3, to assume the defense of such claim, such Indemnified Party may at the expense of the Indemnifying Party contest, settle or consent to the entry of any judgment with respect to, or pay in full, such claim.

18.1.2 Indemnifying Party.

If an Indemnifying Party is obligated to indemnify and hold any Indemnified Party harmless under this Article 18, the amount owing to the Indemnified Party shall be the amount of such Indemnified Party’s actual Loss, net of any insurance or other recovery.

18.1.3 Indemnity Procedures.

Promptly after receipt by an Indemnified Party of any claim or notice of the commencement of any action or administrative or legal proceeding or investigation as to which the indemnity provided for in Article 18.1 may apply, the Indemnified Party shall notify the Indemnifying Party of such fact. Any failure of or delay in such notification shall not affect a

Party's indemnification obligation unless such failure or delay is materially prejudicial to the Indemnifying Party.

Except as stated below, the Indemnifying Party shall have the right to assume the defense thereof with counsel designated by such Indemnifying Party and reasonably satisfactory to the Indemnified Party. If the defendants in any such action include one or more Indemnified Parties and the Indemnifying Party and if the Indemnified Party reasonably concludes that there may be legal defenses available to it and/or other Indemnified Parties which are different from or additional to those available to the Indemnifying Party, the Indemnified Party shall have the right to select separate counsel to assert such legal defenses and to otherwise participate in the defense of such action on its own behalf. In such instances, the Indemnifying Party shall only be required to pay the fees and expenses of one additional attorney to represent an Indemnified Party or Indemnified Parties having such differing or additional legal defenses.

The Indemnified Party shall be entitled, at its expense, to participate in any such action, suit or proceeding, the defense of which has been assumed by the Indemnifying Party. Notwithstanding the foregoing, the Indemnifying Party (i) shall not be entitled to assume and control the defense of any such action, suit or proceedings if and to the extent that, in the opinion of the Indemnified Party and its counsel, such action, suit or proceeding involves the potential imposition of criminal liability on the Indemnified Party, or there exists a conflict or adversity of interest between the Indemnified Party and the Indemnifying Party, in such event the Indemnifying Party shall pay the reasonable expenses of the Indemnified Party, and (ii) shall not settle or consent to the entry of any judgment in any action, suit or proceeding without the consent of the Indemnified Party, which shall not be unreasonably withheld, conditioned or delayed.

18.2 No Consequential Damages.

Other than the indemnity obligations set forth in Article 18.1, in no event shall any Party be liable under any provision of this Agreement for any losses, damages, costs or expenses for any special, indirect, incidental, consequential, or punitive damages, including but not limited to loss of profit or revenue, loss of the use of equipment, cost of capital, cost of temporary equipment or services, whether based in whole or in part in contract, in tort, including negligence, strict liability, or any other theory of liability; provided, however, that damages for which a Party may be liable to another Party under separate agreement will not be considered to be special, indirect, incidental, or consequential damages hereunder.

18.3 Insurance.

Transmission Developer and Connecting Transmission Owner shall each, at its own expense, procure and maintain in force throughout the period of this Agreement and until released by the other Parties, the following minimum insurance coverages, with insurers authorized to do business in the state of New York and rated "A- (minus) VII" or better by A.M. Best & Co. (or if not rated by A.M. Best & Co., a rating entity acceptable to the NYISO):

18.3.1 Workers' Compensation and Employers' Liability Insurance providing statutory benefits in accordance with the laws and regulations of New York State under NCCI Coverage

Form No. WC 00 00 00, as amended or supplemented from time to time, or an equivalent form acceptable to the NYISO; *provided, however*, if the Transmission Project will be located in part outside of New York State, Developer shall maintain such Employers' Liability Insurance coverage with a minimum limit of One Million Dollars (\$1,000,000).

18.3.2 Commercial General Liability Insurance — under ISO Coverage Form No. CG 00 01 (04/13), as amended or supplemented from time to time, or an equivalent form acceptable to the NYISO — with minimum limits of Two Million Dollars (\$2,000,000) per occurrence/Four Million Dollars (\$4,000,000) aggregate combined single limit for personal injury, bodily injury, including death and property damage.

18.3.3 Commercial Business Automobile Liability Insurance — under ISO Coverage Form No. CA 00 01 10 13, as amended or supplemented from time to time, or an equivalent form acceptable to the NYISO — for coverage of owned and non-owned and hired vehicles, trailers or semi-trailers designed for travel on public roads, with a minimum, combined single limit of One Million Dollars (\$1,000,000) per occurrence for bodily injury, including death, and property damage.

18.3.4 Umbrella/Excess Liability Insurance over and above the Employers' Liability, Commercial General Liability, and Commercial Business Automobile Liability Insurance coverage, with a minimum combined single limit of Twenty-Five Million Dollars (\$25,000,000) per occurrence/Twenty-Five Million Dollars (\$25,000,000) aggregate.

18.3.5 Builder's Risk Insurance in a reasonably prudent amount consistent with Good Utility Practice.

18.3.6 The Commercial General Liability Insurance, Commercial Business Automobile Liability Insurance and Umbrella/Excess Liability Insurance policies of Transmission Developer and Connecting Transmission Owner shall each name the other Party and its respective directors, officers, agents, servants and employees (“Other Party Group”) as additional insureds. For Commercial General Liability Insurance, Transmission Developer and Connecting Transmission Owner each shall name the Other Party Group as additional insureds under the following ISO form numbers, as amended or supplemented from time to time, or an equivalent form acceptable to the NYISO: (i) ISO Coverage Form No. CG 20 37 04 13 (“Additional Insured — Owners, Lessees or Contractors — Completed Operations”) and (ii) (A) ISO Coverage Form No. CG 20 10 04 13 (“Additional Insured — Owner, Lessees or Contractors — Scheduled Person or Organization”), or (B) ISO Coverage Form No. CG 20 26 04 13 (“Additional Insured — Designated Person or Organization”). For Commercial Business Automobile Liability Insurance, Transmission Developer and Connecting Transmission Owner shall each name the Other Party Group as additional insureds under ISO Coverage Form No. CA 20 48 10 13 (“Designated Insured for Covered Autos Liability Coverage”), as amended or supplemented from time to time, or an equivalent form acceptable to the NYISO.

18.3.7 All policies shall contain provisions whereby the insurers waive all rights of subrogation in accordance with the provisions of this Agreement against the Other Party Group

and provide thirty (30) Calendar days advance written notice to the Other Party Group prior to non-renewal, cancellation or any material change in coverage or condition.

18.3.8 The Commercial General Liability Insurance, Commercial Business Automobile Liability Insurance and Umbrella/Excess Liability Insurance policies shall contain provisions that specify that the policies are primary and shall apply to such extent without consideration for other policies separately carried and shall state that each insured is provided coverage as though a separate policy had been issued to each, except the insurer's liability shall not be increased beyond the amount for which the insurer would have been liable had only one insured been covered. Each of Transmission Developer and Connecting Transmission Owner shall be responsible for its respective deductibles or retentions.

18.3.9 The Commercial General Liability Insurance, Commercial Business Automobile Liability Insurance and Umbrella/Excess Liability Insurance policies, if written on a Claims First Made Basis in a form acceptable to the NYISO, shall be maintained in full force and effect for two (2) years after termination of this Agreement, which coverage may be in the form of an extended reporting period (ERP) or a separate policy, if agreed by Transmission Developer and Connecting Transmission Owner.

18.3.10 The requirements contained herein as to the types and limits of all insurance to be maintained by the Transmission Developer and Connecting Transmission Owner are not intended to and shall not in any manner, limit or qualify the liabilities and obligations assumed by those Parties under this Agreement.

18.3.11 Each of Transmission Developer and Connecting Transmission Owner shall provide certification of all insurance required in this Agreement, executed by each insurer or by an authorized representative of each insurer: (A) within ten (10) days following: (i) execution of this Agreement, or (ii) the NYISO's date of filing this Agreement if it is filed unexecuted with FERC, and (B) as soon as practicable after the end of each fiscal year or at the renewal of the insurance policy and in any event within thirty (30) days thereafter.

18.3.12 Notwithstanding the foregoing, Transmission Developer and Connecting Transmission Owner may each self-insure to meet the minimum insurance requirements of Articles 18.3.1 through 18.3.9 to the extent it maintains a self-insurance program; provided that, such Party's senior debt is rated at investment grade, or better, by Standard & Poor's and that its self-insurance program meets the minimum insurance requirements of Articles 18.3.1 through 18.3.9. For any period of time that such Party's senior debt is unrated by Standard & Poor's or is rated at less than investment grade by Standard & Poor's, the Party shall comply with the insurance requirements applicable to it under Articles 18.3.1 through 18.3.9. In the event that a Party is permitted to self-insure pursuant to this Article 18.3.12, it shall notify the other Party that it meets the requirements to self-insure and that its self-insurance program meets the minimum insurance requirements in a manner consistent with that specified in Articles 18.3.1 through 18.3.9 and provide evidence of such coverages.

18.3.13 Transmission Developer and Connecting Transmission Owner agree to report to each other in writing as soon as practical all accidents or occurrences resulting in injuries to any person, including death, and any property damage arising out of this Agreement.

18.3.14 Notwithstanding the minimum insurance coverage types and amounts described in this Article 18.3, each of Transmission Developer and Connecting Transmission Owner: (i) shall also maintain any additional insurance coverage types and amounts required under Applicable Laws and Regulations, including New York State law, and under Good Utility Practice for the work performed by such Party and its subcontractors under this Agreement, and (ii) shall satisfy the requirements set forth in Articles 18.3.6 through 18.3.13 with regard to the additional insurance coverages, including naming the Other Party Group as additional insureds under these policies.

ARTICLE 19. ASSIGNMENT

This Agreement may be assigned by a Party only with the written consent of the other Parties; provided that a Party may assign this Agreement without the consent of the other Parties to any Affiliate of the assigning Party with an equal or greater credit rating and with the legal authority and operational ability to satisfy the obligations of the assigning Party under this Agreement; provided further that a Party may assign this Agreement without the consent of the other Parties in connection with the sale, merger, restructuring, or transfer of a substantial

portion or all of its assets, so long as the assignee in such a transaction directly assumes in writing all rights, duties and obligations arising under this Agreement; and provided further that the Transmission Developer shall have the right to assign this Agreement, without the consent of the NYISO or Connecting Transmission Owner, for collateral security purposes to aid in providing financing for the Transmission Project, provided that the Transmission Developer will promptly notify the NYISO and Connecting Transmission Owner of any such assignment. Any financing arrangement entered into by the Transmission Developer pursuant to this Article will provide that prior to or upon the exercise of the secured party's, trustee's or mortgagee's assignment rights pursuant to said arrangement, the secured creditor, the trustee or mortgagee will notify the NYISO and Connecting Transmission Owner of the date and particulars of any such exercise of assignment right(s) and will provide the NYISO and Connecting Transmission Owner with proof that it meets the requirements of Articles 11.4 and 18.3. Any attempted assignment that violates this Article is void and ineffective. Any assignment under this Agreement shall not relieve a Party of its obligations, nor shall a Party's obligations be enlarged, in whole or in part, by reason thereof. Where required, consent to assignment will not be unreasonably withheld, conditioned or delayed.

ARTICLE 20. SEVERABILITY

If any provision in this Agreement is finally determined to be invalid, void or unenforceable by any court or other Governmental Authority having jurisdiction, such determination shall not invalidate, void or make unenforceable any other provision, agreement or covenant of this Agreement.

ARTICLE 21. COMPARABILITY

The Parties will comply with all applicable comparability and code of conduct laws, rules and regulations, as amended from time to time.

ARTICLE 22. CONFIDENTIALITY

22.1 Confidentiality.

Certain information exchanged by the Parties during the term of this Agreement shall constitute confidential information ("Confidential Information") and shall be subject to this Article 22.

If requested by a Party receiving information, the Party supplying the information shall provide in writing, the basis for asserting that the information referred to in this Article warrants confidential treatment, and the requesting Party may disclose such writing to the appropriate Governmental Authority. Each Party shall be responsible for the costs associated with affording confidential treatment to its information.

22.2 Term.

During the term of this Agreement, and for a period of three (3) years after the expiration or termination of this Agreement, except as otherwise provided in this Article 22, each Party shall hold in confidence and shall not disclose to any person Confidential Information.

22.3 Confidential Information.

The following shall constitute Confidential Information: (1) any non-public information that is treated as confidential by the disclosing Party and which the disclosing Party identifies as Confidential Information in writing at the time, or promptly after the time, of disclosure; or (2) information designated as Confidential Information by the NYISO Code of Conduct contained in Attachment F to the ISO OATT.

22.4 Scope.

Confidential Information shall not include information that the receiving Party can demonstrate: (1) is generally available to the public other than as a result of a disclosure by the receiving Party; (2) was in the lawful possession of the receiving Party on a non-confidential basis before receiving it from the disclosing Party; (3) was supplied to the receiving Party without restriction by a third party, who, to the knowledge of the receiving Party after due inquiry, was under no obligation to the disclosing Party to keep such information confidential; (4) was independently developed by the receiving Party without reference to Confidential Information of the disclosing Party; (5) is, or becomes, publicly known, through no wrongful act or omission of the receiving Party or Breach of this Agreement; or (6) is required, in accordance with Article 22.9 of this Agreement, Order of Disclosure, to be disclosed by any Governmental Authority or is otherwise required to be disclosed by law or subpoena, or is necessary in any legal proceeding establishing rights and obligations under this Agreement. Information designated as Confidential Information will no longer be deemed confidential if the Party that designated the information as confidential notifies the other Party that it no longer is confidential.

22.5 Release of Confidential Information.

No Party shall release or disclose Confidential Information to any other person, except to its Affiliates (limited by FERC Standards of Conduct requirements), subcontractors, employees, consultants, or to parties who may be considering providing financing to or equity participation with Transmission Developer, or to potential purchasers or assignees of a Party, on a need-to-know basis in connection with this Agreement, unless such person has first been advised of the confidentiality provisions of this Article 22 and has agreed to comply with such provisions. Notwithstanding the foregoing, a Party providing Confidential Information to any person shall remain primarily responsible for any release of Confidential Information in contravention of this Article 22.

22.6 Rights.

Each Party retains all rights, title, and interest in the Confidential Information that each Party discloses to the other Party. The disclosure by each Party to the other Parties of Confidential Information shall not be deemed a waiver by any Party or any other person or entity of the right to protect the Confidential Information from public disclosure.

22.7 No Warranties.

By providing Confidential Information, no Party makes any warranties or representations as to its accuracy or completeness. In addition, by supplying Confidential Information, no Party obligates itself to provide any particular information or Confidential Information to the other Parties nor to enter into any further agreements or proceed with any other relationship or joint venture.

22.8 Standard of Care.

Each Party shall use at least the same standard of care to protect Confidential Information it receives as it uses to protect its own Confidential Information from unauthorized disclosure, publication or dissemination. Each Party may use Confidential Information solely to fulfill its obligations to the other Parties under this Agreement or its regulatory requirements, including the ISO OATT and NYISO Services Tariff. The NYISO shall, in all cases, treat the information it receives in accordance with the requirements of Attachment F to the ISO OATT.

22.9 Order of Disclosure.

If a court or a Government Authority or entity with the right, power, and apparent authority to do so requests or requires any Party, by subpoena, oral deposition, interrogatories, requests for production of documents, administrative order, or otherwise, to disclose Confidential Information, that Party shall provide the other Parties with prompt notice of such request(s) or requirement(s) so that the other Parties may seek an appropriate protective order or waive compliance with the terms of this Agreement. Notwithstanding the absence of a protective order or waiver, the Party may disclose such Confidential Information which, in the opinion of its counsel, the Party is legally compelled to disclose. Each Party will use Reasonable Efforts to obtain reliable assurance that confidential treatment will be accorded any Confidential Information so furnished.

22.10 Termination of Agreement.

Upon termination of this Agreement for any reason, each Party shall, within ten (10) Calendar Days of receipt of a written request from the other Parties, use Reasonable Efforts to destroy, erase, or delete (with such destruction, erasure, and deletion certified in writing to the other Parties) or return to the other Parties, without retaining copies thereof, any and all written or electronic Confidential Information received from the other Parties pursuant to this Agreement.

22.11 Remedies.

The Parties agree that monetary damages would be inadequate to compensate a Party for another Party's Breach of its obligations under this Article 22. Each Party accordingly agrees that the other Parties shall be entitled to equitable relief, by way of injunction or otherwise, if the first Party Breaches or threatens to Breach its obligations under this Article 22, which equitable relief shall be granted without bond or proof of damages, and the receiving Party shall not plead in defense that there would be an adequate remedy at law. Such remedy shall not be deemed an exclusive remedy for the Breach of this Article 22, but shall be in addition to all other remedies

available at law or in equity. The Parties further acknowledge and agree that the covenants contained herein are necessary for the protection of legitimate business interests and are reasonable in scope. No Party, however, shall be liable for indirect, incidental, or consequential or punitive damages of any nature or kind resulting from or arising in connection with this Article 22.

22.12 Disclosure to FERC, its Staff, or a State.

Notwithstanding anything in this Article 22 to the contrary, and pursuant to 18 C.F.R. section 1b.20, if FERC or its staff, during the course of an investigation or otherwise, requests information from one of the Parties that is otherwise required to be maintained in confidence pursuant to this Agreement or the ISO OATT, the Party shall provide the requested information to FERC or its staff, within the time provided for in the request for information. In providing the information to FERC or its staff, the Party must, consistent with 18 C.F.R. section 388.112, request that the information be treated as confidential and non-public by FERC and its staff and that the information be withheld from public disclosure. Parties are prohibited from notifying the other Parties to this Agreement prior to the release of the Confidential Information to the Commission or its staff. The Party shall notify the other Parties to the Agreement when it is notified by FERC or its staff that a request to release Confidential Information has been received by FERC, at which time the Parties may respond before such information would be made public, pursuant to 18 C.F.R. section 388.112. Requests from a state regulatory body conducting a confidential investigation shall be treated in a similar manner if consistent with the applicable state rules and regulations. A Party shall not be liable for any losses, consequential or otherwise, resulting from that Party divulging Confidential Information pursuant to a FERC or state regulatory body request under this paragraph.

22.13 Required Notices Upon Requests or Demands for Confidential Information

Except as otherwise expressly provided herein, no Party shall disclose Confidential Information to any person not employed or retained by the Party possessing the Confidential Information, except to the extent disclosure is (i) required by law; (ii) reasonably deemed by the disclosing Party to be required to be disclosed in connection with a dispute between or among the Parties, or the defense of litigation or dispute; (iii) otherwise permitted by consent of the other Party, such consent not to be unreasonably withheld; or (iv) necessary to fulfill its obligations under this Agreement, the ISO OATT or the NYISO Services Tariff. Prior to any disclosures of a Party's Confidential Information under this subparagraph, or if any third party or Governmental Authority makes any request or demand for any of the information described in this subparagraph, the disclosing Party agrees to promptly notify the other Party in writing and agrees to assert confidentiality and cooperate with the other Party in seeking to protect the Confidential Information from public disclosure by confidentiality agreement, protective order or other reasonable measures.

ARTICLE 23. TRANSMISSION DEVELOPER AND CONNECTING TRANSMISSION OWNER NOTICES OF ENVIRONMENTAL RELEASES

Transmission Developer and Connecting Transmission Owner shall each notify the other Party, first orally and then in writing, of the release of any Hazardous Substances, any asbestos

or lead abatement activities, or any type of remediation activities related to the Transmission Project or Network Upgrade Facilities, each of which may reasonably be expected to affect the other Party. The notifying Party shall: (i) provide the notice as soon as practicable, provided such Party makes a good faith effort to provide the notice no later than twenty-four hours after such Party becomes aware of the occurrence; and (ii) promptly furnish to the other Party copies of any publicly available reports filed with any Governmental Authorities addressing such events.

ARTICLE 24. INFORMATION REQUIREMENT

24.1 Information Acquisition.

Connecting Transmission Owner and Transmission Developer shall each submit specific information regarding the electrical characteristics of their respective facilities to the other, and to NYISO, as described below and in accordance with Applicable Reliability Standards.

24.2 Information Submission Concerning the Network Upgrade Facilities.

The initial information submission by Connecting Transmission Owner shall occur no later than one hundred eighty (180) Calendar Days prior to Trial Operation of the Network Upgrade Facilities and shall include New York State Transmission System information necessary to allow the Transmission Developer to select equipment and meet any system protection and stability requirements, unless otherwise mutually agreed to by the Transmission Developer and Connecting Transmission Owner. On a quarterly basis Transmission Developer shall provide the other Parties a status report on the construction and installation of the Network Upgrade Facilities, including, but not limited to, the following information: (1) progress to date; (2) a description of the activities since the last report; (3) a description of the action items for the next period; and (4) the delivery status of equipment ordered.

24.3 Updated Information Submission Concerning the Transmission Project.

The updated information submission by the Transmission Developer, including manufacturer information, shall occur no later than one hundred eighty (180) Calendar Days prior to the Trial Operation of the Transmission Project. Transmission Developer shall submit a completed copy of the Transmission Project data requirements contained in Appendix 1 to the Transmission Interconnection Procedures. It shall also include any additional information provided to Connecting Transmission Owner for the Facilities Study. Information in this submission shall be the most current Transmission Project design or expected performance data. Information submitted for stability models shall be compatible with NYISO standard models. If there is no compatible model, the Transmission Developer will work with a consultant mutually agreed to by the Parties to develop and supply a standard model and associated information.

If the Transmission Developer's data is different from what was originally provided to Connecting Transmission Owner and NYISO pursuant to a Transmission Interconnection Study agreement among Connecting Transmission Owner, NYISO and Transmission Developer and this difference may be reasonably expected to affect the other Parties' facilities or the New York State Transmission System, but does not require the submission of a new Transmission

Interconnection Application, then NYISO will conduct appropriate studies to determine the impact on the New York State Transmission System based on the actual data submitted pursuant to this Article 24.3. Such studies will provide an estimate of any additional modifications to the New York State Transmission System or Network Upgrade Facilities based on the actual data and a good faith estimate of the costs thereof. The Transmission Developer shall not begin Trial Operation for the Transmission Project until such studies are completed. The Transmission Developer shall be responsible for the cost of any modifications required by the actual data, including the cost of any required studies.

24.4 Information Supplementation.

Prior to the In-Service Date, the Transmission Developer and Connecting Transmission Owner shall supplement their information submissions described above in this Article 24 with any and all “as-built” Transmission Project and Network Upgrade Facilities information or “as-tested” performance information that differs from the initial submissions or, alternatively, written confirmation that no such differences exist. The Transmission Developer shall conduct tests on the Transmission Project as required by Good Utility Practice.

Subsequent to the In-Service Date, the Transmission Developer shall provide Connecting Transmission Owner and NYISO any information changes concerning the Transmission Project and the Network Upgrade Facilities it owns as specified in Appendix C due to equipment replacement, repair, or adjustment. Connecting Transmission Owner shall provide the Transmission Developer and NYISO any information changes concerning the Network Upgrade Facilities that it owns as specified in Appendix C due to equipment replacement, repair or adjustment in the directly connected substation or any adjacent Connecting Transmission Owner substation that may affect the Transmission Project’s equipment ratings, protection or operating requirements. The Transmission Developer and Connecting Transmission Owner shall provide such information no later than thirty (30) Calendar Days after the date of the equipment replacement, repair or adjustment.

ARTICLE 25. INFORMATION ACCESS AND AUDIT RIGHTS

25.1 Information Access.

Each Party (“Disclosing Party”) shall make available to another Party (“Requesting Party”) information that is in the possession of the Disclosing Party and is necessary in order for the Requesting Party to: (i) verify the costs incurred by the Disclosing Party for which the Requesting Party is responsible under this Agreement; and (ii) carry out its obligations and responsibilities under this Agreement. The Parties shall not use such information for purposes other than those set forth in this Article 25.1 of this Agreement and to enforce their rights under this Agreement.

25.2 Reporting of Non-Force Majeure Events.

Each Party (the “Notifying Party”) shall notify the other Parties when the Notifying Party becomes aware of its inability to comply with the provisions of this Agreement for a reason other than a Force Majeure event. The Parties agree to cooperate with each other and provide

necessary information regarding such inability to comply, including the date, duration, reason for the inability to comply, and corrective actions taken or planned to be taken with respect to such inability to comply. Notwithstanding the foregoing, notification, cooperation or information provided under this Article shall not entitle the Party receiving such notification to allege a cause for anticipatory breach of this Agreement.

25.3 Audit Rights.

Subject to the requirements of confidentiality under Article 22 of this Agreement, each Party shall have the right, during normal business hours, and upon prior reasonable notice to another Party, to audit at its own expense the other Party's accounts and records pertaining to the other Party's performance or satisfaction of its obligations under this Agreement. Such audit rights shall include audits of the other Party's costs, calculation of invoiced amounts, and each Party's actions in an Emergency or Emergency State. Any audit authorized by this Article shall be performed at the offices where such accounts and records are maintained and shall be limited to those portions of such accounts and records that relate to the Party's performance and satisfaction of obligations under this Agreement. Each Party shall keep such accounts and records for a period equivalent to the audit rights periods described in Article 25.4 of this Agreement.

25.4 Audit Rights Periods.

25.4.1 Audit Rights Period for Construction-Related Accounts and Records.

Accounts and records related to the design, engineering, procurement, and construction of the Network Upgrade Facilities shall be subject to audit for a period of twenty-four months following Connecting Transmission Owner's issuance of a final invoice in accordance with Article 12.2 of this Agreement.

25.4.2 Audit Rights Period for All Other Accounts and Records.

Accounts and records related to a Party's performance or satisfaction of its obligations under this Agreement other than those described in Article 25.4.1 of this Agreement shall be subject to audit as follows: (i) for an audit relating to cost obligations, the applicable audit rights period shall be twenty-four months after the auditing Party's receipt of an invoice giving rise to such cost obligations; and (ii) for an audit relating to all other obligations, the applicable audit rights period shall be twenty-four months after the event for which the audit is sought.

25.5 Audit Results.

If an audit by a Party determines that an overpayment or an underpayment has occurred, a notice of such overpayment or underpayment shall be given to the other Party together with those records from the audit which support such determination.

ARTICLE 26. SUBCONTRACTORS

26.1 General.

Nothing in this Agreement shall prevent a Party from utilizing the services of any subcontractor as it deems appropriate to perform its obligations under this Agreement; provided, however, that each Party shall require its subcontractors to comply with all applicable terms and conditions of this Agreement in providing such services and each Party shall remain primarily liable to the other Parties for the performance of such subcontractor.

26.2 Responsibility of Principal.

The creation of any subcontract relationship shall not relieve the hiring Party of any of its obligations under this Agreement. The hiring Party shall be fully responsible to the other Parties for the acts or omissions of any subcontractor the hiring Party hires as if no subcontract had been made; provided, however, that in no event shall the NYISO or Connecting Transmission Owner be liable for the actions or inactions of the Transmission Developer or its subcontractors with respect to obligations of the Transmission Developer under Article 5 of this Agreement. Any applicable obligation imposed by this Agreement upon the hiring Party shall be equally binding upon, and shall be construed as having application to, any subcontractor of such Party.

26.3 No Limitation by Insurance.

The obligations under this Article 26 will not be limited in any way by any limitation of subcontractor's insurance.

ARTICLE 27. DISPUTES

27.1 Submission.

In the event any Party has a dispute, or asserts a claim, that arises out of or in connection with this Agreement or its performance (a "Dispute"), such Party shall provide the other Parties with written notice of the Dispute ("Notice of Dispute"). Such Dispute shall be referred to a designated senior representative of each Party for resolution on an informal basis as promptly as practicable after receipt of the Notice of Dispute by the other Parties. In the event the designated representatives are unable to resolve the Dispute through unassisted or assisted negotiations within thirty (30) Calendar Days of the other Parties' receipt of the Notice of Dispute, such Dispute may, upon mutual agreement of the Parties, be submitted to arbitration and resolved in accordance with the arbitration procedures set forth below. In the event the Parties do not agree to submit such Dispute to arbitration, each Party may exercise whatever rights and remedies it may have in equity or at law consistent with the terms of this Agreement.

27.2 External Arbitration Procedures.

Any arbitration initiated under this Agreement shall be conducted before a single neutral arbitrator appointed by the Parties. If the Parties fail to agree upon a single arbitrator within ten (10) Calendar Days of the submission of the Dispute to arbitration, each Party shall choose one arbitrator who shall sit on a three-member arbitration panel. In each case, the arbitrator(s) shall

be knowledgeable in electric utility matters, including electric transmission and bulk power issues, and shall not have any current or past substantial business or financial relationships with any party to the arbitration (except prior arbitration). The arbitrator(s) shall provide each of the Parties an opportunity to be heard and, except as otherwise provided herein, shall conduct the arbitration in accordance with the Commercial Arbitration Rules of the American Arbitration Association (“Arbitration Rules”) and any applicable FERC regulations or RTO rules; provided, however, in the event of a conflict between the Arbitration Rules and the terms of this Article 27, the terms of this Article 27 shall prevail.

27.3 Arbitration Decisions.

Unless otherwise agreed by the Parties, the arbitrator(s) shall render a decision within ninety (90) Calendar Days of appointment and shall notify the Parties in writing of such decision and the reasons therefor. The arbitrator(s) shall be authorized only to interpret and apply the provisions of this Agreement and shall have no power to modify or change any provision of this Agreement in any manner. The decision of the arbitrator(s) shall be final and binding upon the Parties, and judgment on the award may be entered in any court having jurisdiction. The decision of the arbitrator(s) may be appealed solely on the grounds that the conduct of the arbitrator(s), or the decision itself, violated the standards set forth in the Federal Arbitration Act or the Administrative Dispute Resolution Act. The final decision of the arbitrator must also be filed with FERC if it affects jurisdictional rates, terms and conditions of service, or Network Upgrade Facilities.

27.4 Costs.

Each Party shall be responsible for its own costs incurred during the arbitration process and for the following costs, if applicable: (1) the cost of the arbitrator chosen by the Party to sit on the three member panel; or (2) one-third the cost of the single arbitrator jointly chosen by the Parties.

27.5 Termination.

Notwithstanding the provisions of this Article 27, any Party may terminate this Agreement in accordance with its provisions or pursuant to an action at law or equity. The issue of whether such a termination is proper shall not be considered a Dispute hereunder.

ARTICLE 28. REPRESENTATIONS, WARRANTIES AND COVENANTS

28.1 General.

Each Party makes the following representations, warranties and covenants:

28.1.1 Good Standing.

Such Party is duly organized, validly existing and in good standing under the laws of the state in which it is organized, formed, or incorporated, as applicable; that it is qualified to do business in the state or states in which the Transmission Project and Network Upgrade Facilities owned by such Party, as applicable, are located; and that it has the corporate power and authority

to own its properties, to carry on its business as now being conducted and to enter into this Agreement and carry out the transactions contemplated hereby and perform and carry out all covenants and obligations on its part to be performed under and pursuant to this Agreement.

28.1.2 Authority.

Such Party has the right, power and authority to enter into this Agreement, to become a Party hereto and to perform its obligations hereunder. This Agreement is a legal, valid and binding obligation of such Party, enforceable against such Party in accordance with its terms, except as the enforceability thereof may be limited by applicable bankruptcy, insolvency, reorganization or other similar laws affecting creditors' rights generally and by general equitable principles (regardless of whether enforceability is sought in a proceeding in equity or at law).

28.1.3 No Conflict.

The execution, delivery and performance of this Agreement does not violate or conflict with the organizational or formation documents, or bylaws or operating agreement, of such Party, or any judgment, license, permit, order, material agreement or instrument applicable to or binding upon such Party or any of its assets.

28.1.4 Consent and Approval.

Such Party has sought or obtained, or, in accordance with this Agreement will seek or obtain, each consent, approval, authorization, order, or acceptance by any Governmental Authority in connection with the execution, delivery and performance of this Agreement, and it will provide to any Governmental Authority notice of any actions under this Agreement that are required by Applicable Laws and Regulations.

ARTICLE 29. MISCELLANEOUS

29.1 Binding Effect.

This Agreement and the rights and obligations hereof, shall be binding upon and shall inure to the benefit of the successors and permitted assigns of the Parties hereto.

29.2 Conflicts.

If there is a discrepancy or conflict between or among the terms and conditions of this cover agreement and the Appendices hereto, the terms and conditions of this cover agreement shall be given precedence over the Appendices, except as otherwise expressly agreed to in writing by the Parties.

29.3 Rules of Interpretation.

This Agreement, unless a clear contrary intention appears, shall be construed and interpreted as follows: (1) the singular number includes the plural number and vice versa; (2) reference to any person includes such person's successors and assigns but, in the case of a Party,

only if such successors and assigns are permitted by this Agreement, and reference to a person in a particular capacity excludes such person in any other capacity or individually; (3) reference to any agreement (including this Agreement), document, instrument or tariff means such agreement, document, instrument, or tariff as amended or modified and in effect from time to time in accordance with the terms thereof and, if applicable, the terms hereof; (4) reference to any Applicable Laws and Regulations means such Applicable Laws and Regulations as amended, modified, codified, or reenacted, in whole or in part, and in effect from time to time, including, if applicable, rules and regulations promulgated thereunder; (5) unless expressly stated otherwise, reference to any Article, Section or Appendix means such Article of this Agreement or such Appendix to this Agreement, or such Section to the Transmission Interconnection Procedures or such Appendix to the Transmission Interconnection Procedures, as the case may be; (6) “hereunder”, “hereof”, “herein”, “hereto” and words of similar import shall be deemed references to this Agreement as a whole and not to any particular Article or other provision hereof or thereof; (7) “including” (and with correlative meaning “include”) means including without limiting the generality of any description preceding such term; and (8) relative to the determination of any period of time, “from” means “from and including”, “to” means “to but excluding” and “through” means “through and including”.

29.4 Compliance.

Each Party shall perform its obligations under this Agreement in accordance with Applicable Laws and Regulations, Applicable Reliability Standards, the ISO OATT and Good Utility Practice. To the extent a Party is required or prevented or limited in taking any action by such regulations and standards, such Party shall not be deemed to be in Breach of this Agreement for its compliance therewith. When any Party becomes aware of such a situation, it shall notify the other Parties promptly so that the Parties can discuss the amendment to this Agreement that is appropriate under the circumstances.

29.5 Joint and Several Obligations.

Except as otherwise stated herein, the obligations of NYISO, Transmission Developer and Connecting Transmission Owner are several, and are neither joint nor joint and several.

29.6 Entire Agreement.

This Agreement, including all Appendices and Schedules attached hereto, constitutes the entire agreement between the Parties with reference to the subject matter hereof, and supersedes all prior and contemporaneous understandings or agreements, oral or written, between the Parties with respect to the subject matter of this Agreement. There are no other agreements, representations, warranties, or covenants which constitute any part of the consideration for, or any condition to, either Party’s compliance with its obligations under this Agreement.

29.7 No Third Party Beneficiaries.

This Agreement is not intended to and does not create rights, remedies, or benefits of any character whatsoever in favor of any persons, corporations, associations, or entities other than the Parties, and the obligations herein assumed are solely for the use and benefit of the Parties, their successors in interest and permitted their assigns.

29.8 Waiver.

The failure of a Party to this Agreement to insist, on any occasion, upon strict performance of any provision of this Agreement will not be considered a waiver of any obligation, right, or duty of, or imposed upon, such Party. Any waiver at any time by either Party of its rights with respect to this Agreement shall not be deemed a continuing waiver or a waiver with respect to any other failure to comply with any other obligation, right, duty of this Agreement. Termination or Default of this Agreement for any reason by the Transmission Developer shall not constitute a waiver of the Transmission Developer's legal rights to obtain Capacity Resource Interconnection Service and Energy Resource Interconnection Service from the NYISO and Connecting Transmission Owner in accordance with the provisions of the ISO OATT. Any waiver of this Agreement shall, if requested, be provided in writing.

29.9 Headings.

The descriptive headings of the various Articles of this Agreement have been inserted for convenience of reference only and are of no significance in the interpretation or construction of this Agreement.

29.10 Multiple Counterparts.

This Agreement may be executed in two or more counterparts, each of which is deemed an original but all constitute one and the same instrument.

29.11 Amendment.

The Parties may by mutual agreement amend this Agreement, by a written instrument duly executed by all three of the Parties.

29.12 Modification by the Parties.

The Parties may by mutual agreement amend the Appendices to this Agreement, by a written instrument duly executed by all three of the Parties. Such an amendment shall become effective and a part of this Agreement upon satisfaction of all Applicable Laws and Regulations.

29.13 Reservation of Rights.

NYISO and Connecting Transmission Owner shall have the right to make unilateral filings with FERC to modify this Agreement with respect to any rates, terms and conditions, charges, classifications of service, rule or regulation under section 205 or any other applicable provision of the Federal Power Act and FERC's rules and regulations thereunder, and Transmission Developer shall have the right to make a unilateral filing with FERC to modify this Agreement pursuant to section 206 or any other applicable provision of the Federal Power Act and FERC's rules and regulations thereunder; provided that each Party shall have the right to protest any such filing by another Party and to participate fully in any proceeding before FERC in which such modifications may be considered. Nothing in this Agreement shall limit the rights of the Parties or of FERC under sections 205 or 206 of the Federal Power Act and FERC's rules

and regulations thereunder, except to the extent that the Parties otherwise mutually agree as provided herein.

29.14 No Partnership.

This Agreement shall not be interpreted or construed to create an association, joint venture, agency relationship, or partnership among the Parties or to impose any partnership obligation or partnership liability upon any Party. No Party shall have any right, power or authority to enter into any agreement or undertaking for, or act on behalf of, or to act as or be an agent or representative of, or to otherwise bind, any other Party.

29.15 Other Transmission Rights.

Notwithstanding any other provision of this Agreement, nothing herein shall be construed as relinquishing or foreclosing any rights, including but not limited to firm transmission rights, capacity rights, or transmission congestion rights that the Transmission Developer shall be entitled to, now or in the future under any other agreement or tariff as a result of, or otherwise associated with, the transmission capacity, if any, created by the Transmission Project and Network Upgrade Facilities.

IN WITNESS WHEREOF, the Parties have executed this Agreement in duplicate originals, each of which shall constitute and be an original effective Agreement between the Parties.

New York Independent System Operator, Inc.

By: _____

Name: _____

Title: _____

Date: _____

New York State Electric & Gas Corporation

By: _____

By: _____

Name: _____

Name: _____

Title: _____

Title: _____

Date: _____

Date: _____

NextEra Energy Transmission New York, Inc.

By: _____

Name: _____

Title: _____

Date: _____

APPENDICES

Appendix A

Network Upgrade Facilities

Appendix B

Milestones

Appendix C

Interconnection Details

Appendix D

Security Arrangements Details

Appendix E-1

Initial Synchronization Date

Appendix E-2

In-Service Date

Appendix F

Addresses for Delivery of Notices and Billings

APPENDIX A

NETWORK UPGRADE FACILITIES

1. Network Upgrade Facilities (“NUFs”)

A. Network Upgrade Facilities for Connecting Transmission Owner’s Transmission System

The Transmission Project will interconnect to the New York State Transmission System at existing transmission facilities owned and operated by the Connecting Transmission Owner as depicted in Figure A-1. The Facilities Study identified NUFs required to reliably interconnect the Transmission Project to the Connecting Transmission Owner’s system. These NUFs are described below.

i. Upgrading the Erie St. 115 kV Substation Terminal to Depew

The Transmission Developer will upgrade the Erie St. line terminal for line #921, so that the line rating of 125/152/181 MVA (Normal/LTE/STE) is not limited. This work will include the following major electrical and physical equipment:

- Replace existing oil breaker 92142 with a new 145 kV, 3000 A, 63 kA, 650 kV basic insulation level (“BIL”) sulfur hexafluoride (“SF6”) breaker; equipped with 2 sets of 2000:5 multi ratio (“MR”), C800 current transformers (“CTs”) on each bushing, and 1 set of 1200/5A single ratio (“SR”), 0.15B1.8, RF 1.5 metering CTs;
- Replace existing breaker foundation with new 115 kV breaker foundation;
- Install one (1) new 121 kV coupling capacitor voltage transformer (“CCVT”), which replaces the existing bushing potential device (“BPD”) located on existing breaker;
- Install CCVT structure and foundation;
- Install CCVT junction box;
- Install grounding materials;
- Install conduit; control cabling; and
- Install bus work.

This work will include the following major protection and control equipment:

- Replace existing breaker failure electromechanical relay package with one (1) SEL-451 bay control relay;
- Replace existing system A electromechanical relay package with one (1) SEL-411L system A line protection relay;
- Replace existing system B electromechanical relay package with one (1) GE-L90 system B line protection and system B breaker failure relay;
- Install nine (9) ABB FT-19R test switches;
- Install three (3) 19” rack mount adapter plates;
- Install a GPS clock for time synchronization; and
- Install a new communication processor for new microprocessor relays.

- There will be no modifications to the existing communication system (leased telephone line) and the RFL GARD 8000 equipment for Line 921.

ii. Upgrading the Stolle Road to Roll Road 115 kV Terminal Equipment

The Transmission Developer will upgrade the Stolle Road line terminal for line #928, so that the line rating of 176/196/225 MVA (Normal/LTE/STE) is not limited. This work will include the following major protection and control equipment:

- Replace existing breaker failure electromechanical relay package with one (1) SEL-451 bay control relay;
- Replace existing system A electromechanical relay package with one (1) SEL411L system A line protection relay;
- Replace existing system B electromechanical relay package with one (1) GEL90 system B line protection and system B breaker failure relay;
- Install nine (9) ABB FT-19R test switches; and
- Install three (3) 19" rack mount adapter plates.

iii. Upgrading Line Protection Systems at Somerset/Kintigh Substation

The Transmission Developer will upgrade the NS1-38 line protection system of the NS1-38 terminal at the 345 kV Somerset/Kintigh Substation. This work will include the following major protection and control equipment at the NS1-38 terminal:

- Three (3) new relay panels to house the following:
 - One (1) SEL411L system A line protection relay;
 - One (1) RFL GARD 8000;
 - One (1) GE-L90 system B line protection relay;
 - Two (2) SEL-451 bay control relays for circuit breakers 38/B312 and B1/3812;
 - Ten (10) FT-19R test switch assemblies;
 - JMUX T1 multiplexer chassis; and
 - Removal of existing line relay equipment associated with Line 38 and the existing breaker failure relaying associated with circuit breakers 38/B312 and B1/3812.

The Transmission Developer will upgrade the SH1-39 line protection system of the SH1-39 terminal at the 345 kV Somerset/Kintigh Substation. This work will include the following major protection and control equipment at the SH1-39 terminal:

- Replace the existing SEL421 system A line protection relay with a SEL411L.

iv. Upgrading Line Protection Systems at Stolle Road 345kV

The Transmission Developer will upgrade the existing Stolle Road-NGRID Five Mile (Line 29) line protection systems at the 345 kV Stolle Road Substation. This work will include the following major protection and control equipment at the Stolle to East Stolle line terminal:

- Replace existing system A line relay (SEL-421) with one (1) SEL-411L system A line protection relay utilizing a line differential protection scheme;
- Replace existing system B line relay (Siemens SIPROTEC) with one (1) GE-L90 system 2 line protection relay utilizing a line differential protection scheme;
- Twelve (12) FT-1 test switches;
- Remove existing line trap and line tuner;
- Remove existing System A RFL 9785 and RFL 9780 powerline carrier system devices;
- Remove existing System B RFL GARD 8000 device and disconnect the existing System B relay communications (JMUX over leased line);
- Install two (2) distinct fiber optic cables for the new line differential protection between Stolle Rd and East Stolle Rd;
- Optical ground wire (“OPGW”) will be used for system A and all-dielectric self-supporting (“ADSS”) routed underground will be used for system B; and
- Install two (2) fiber patch panels to terminate the two distinct fiber cables required for the new System A and System B relaying.

v. Connecting Two Connecting Transmission Owner 345kV Lines #38 and #39 into New Transmission Project 345 kV Dysinger Substation

The Transmission Developer will re-route lines #38 and #39 just south of its existing structure #5 on new steel three pole angle dead-end structures toward the west to new steel single pole angle dead-end structure or three pole angle dead-end and then span south into the Transmission Developer’s new Dysinger Substation. The eastern line (#39) will cross over the Connecting Transmission Owner’s existing 230 kV line #65. The Connecting Transmission Owner’s existing structures and conductors from New York Power Authority (“NYPA”) tap to structure #4 will be removed.

This work will include the following major electrical and physical equipment:

- Install one (1) new single circuit, single steel pole dead-end structure (Str D-S1-1);
- Install one (1) new single circuit, three steel pole dead-end structure (D-S2-1);
- Install two (2) new single circuit, three steel pole dead-end structures (D-S2-2, D-S1-2) based on Connecting Transmission Owner’s standards;
- String approximately 3,500 circuit feet of (2 bundle/phase) 1192.5 kcmil 45/7 stranded aluminum-conductor steel-reinforced (“ACSR”) “Bunting” conductor;
- String approximately 5,000 total feet of two 7/16” extra high strength (“EHS”) overhead groundwire;
- Remove eight (8) existing structures (4 three pole structures and 4 wood h-frames) and associated material from Dysinger Junction to the proposed tap;
- Remove existing conductor and ground wires for a total circuit length of approximately 1.2 miles between Dysinger Junction and the proposed tap;
- Remove the jumpers to Connecting Transmission Owner’s lines #NS1-38 and #SH1-39 from the Connecting Transmission Owner’s line to the NS1-38 and SH1-39 lines at the existing Dysinger Junction, which structures at this location are three (3) monopoles and

will remain in the existing right-of-way to minimize the use of full tension aerial splices for the existing Connecting Transmission Owner's transmission lines (see Figure A-2 for more details);

- Develop new transmission jumpers (2 bundle/phase) 795kcmil 26/7 stranded ACSR "Drake" conductor; for the existing three (3) pole structures to complete the circuit between the proposed Dysinger Switchyard and Rochester Gas and Electric Corporation's Station 255;

vi. Connecting the Connecting Transmission Owner-owned Stolle Rd. to Five Mile 345 kV Line #29 into East Stolle Rd. Substation

Transmission Developer will remove the existing lattice tower #F-1. Transmission Developer will install six (6) new steel single pole dead-end structures (ES-S1, ES-S2, ES-H1, ES-H2, ES-S3, ES-H3) designed to Connecting Transmission Owner's standards. The Connecting Transmission Owner's existing 345 kV line #29 (to Five Mile) will be rerouted on to the new steel dead-end structures into the Transmission Developer's new East Stolle Switchyard. A new Connecting Transmission Owner 345 kV tie line between Transmission Developer's East Stolle Substation and Connecting Transmission Owner's existing Stolle Substation will come out of Connecting Transmission Owner's existing 345 kV bay on the new steel deadend structures.

This work will include the following major electrical and physical equipment:

- Install two (2) new single circuit structures, consisting of six (6) steel pole dead-end structures with caisson foundations;
- String approximately 2,500 circuit feet of (2 bundle/phase) 1033.5kcmil 45/7 stranded ACSR "Ortolan" conductor;
- String approximately 3,600 total feet of overhead ground wire;
- String approximately 1,500 total feet of Connecting Transmission Owner approved optical ground wire;
- Remove existing F-1 lattice structure and foundations; and
- Remove existing conductor and ground wire from a 261 foot span on line #29.

B. Network Upgrade Facilities for NYPA's Transmission System

Portions of the Transmission Project will also interconnect to the New York State Transmission System at existing transmission facilities owned and operated by the New York Power Authority ("NYPA"), which is also a Connecting Transmission Owner for the Transmission Project. The Facilities Study identified certain Network Upgrade Facilities required to reliably interconnect the Transmission Project to NYPA's system. These include:

- Looping two existing NYPA-owned 345 kV lines in and out of the Transmission Developer's new Dysinger Substation (lines NS-1, NR2, NH-2 and SH1-39); and
- Upgrading line protection systems at NYPA's Niagara 345 kV Substation.

The Transmission Developer, NYPA, and the NYISO have entered into a separate Transmission Project Interconnection Agreement concerning the interconnection of the Transmission Project to NYPA's facilities and the related Network Upgrade Facilities.

C. Affected System Upgrade Facilities

The Transmission Interconnection Studies for the Transmission Project identified Rochester Gas and Electric Corporation ("RG&E") and Niagara Mohawk Power Corporation d/b/a National Grid ("National Grid") as Affected System Operators, which systems are impacted by the Transmission Project. The Facilities Studies conducted for the Transmission Project identified certain Network Upgrade Facilities required for these Affected Systems.

The Facilities Studies identified the following work on RG&E's transmission facilities:

- Add a new 100 Mvar shunt reactor at its Rochester Station 80 345 kV Substation; and
- Upgrade line protection systems at its Station 255 Substation.

This work will be performed in accordance with the terms of an engineering, procurement, and construction agreement by and among the NYISO, Transmission Developer, and RG&E.

The Facilities Studies identified the following work on National Grid's transmission facilities:

- Modifications to its Five Mile Station, including updates to its protection, controls & integration, and telecommunications equipment; and
- Integrate the Transmission Developer's New Dysinger Station into National Grid's SONET ring used for line protection.

This work will be performed in accordance with the terms of an engineering, procurement, and construction agreement by and among the NYISO, Transmission Developer, and National Grid.

2. Connecting Transmission Owner's and Transmission Developer's Responsibilities Concerning Network Upgrade Facilities

Transmission Developer will be responsible for engineering, designing, procuring, constructing, installing, updating relay settings, commissioning, and testing of all Network Upgrade Facilities identified in Section A of this Appendix A. Connecting Transmission Owner will work with Transmission Developer to ensure that Connecting Transmission Owner's requirements are applied to those Network Upgrade Facilities, unless otherwise agreed to by Transmission Developer and Connecting Transmission Owner.

The Transmission Developer will design, procure, engineer and construct the new and modified NUFs in accordance with Connecting Transmission Owner's Bulletin No. 86-01, Requirements for the Interconnection of Generation, Transmission and End-User Facilities (Revised October 3, 2011) ("Bulletin 86-01") and the Connecting Transmission Owner's Bulk Power POI Guide, to the extent they are not inconsistent with the terms of this Agreement, the

NYISO OATT, or the Operating Agreement. The Connection Transmission Owner will provide project management, owners engineer (“OE”) and full construction oversight (“FCM”).

Consistent with Section 5.2.1 of this Agreement, all project engineering and design work shall be per the Connecting Transmission Owner’s Engineering, Design & Construction Standards. Consistent with Section 5.2.3 of this Agreement, all of the Transmission Developer’s engineering and design documentation shall be approved by the Connecting Transmission Owner. The work for the NUFs shall be per the Connecting Transmission Owner’s standards and under the supervision of a Connecting Transmission Owner’s FCM, unless the NUFs are to be owned by the Transmission Developer, in which case, the Transmission Developer’s standards will apply. A list of engineering contractors and substation construction contractors currently approved by the Connecting Transmission Owner is available. However, the Transmission Developer may propose an alternate engineering contractor and/or substation construction contractor for review and acceptance by the Connecting Transmission Owner.

In addition, Transmission Developer shall:

- Provide control plan, maintenance plan, or emergency callout plan for their stations;
- Coordinate relay testing between the Connecting Transmission Owners that connect to the Transmission Developer’s stations; and
- Coordinate and plan who will report on all 115 kV and above line faults associated with the Transmission Project and how that will be coordinated between the Transmission Owners and Transmission Developer.

Protection Considerations:

- The protection used for the two lines from Kintigh to Dysinger should be identical. This will require identical SEL and GE relays to be used for the A and B systems at each end of each line as well as same for all associated communications equipment for high speed line protection and direct transfer trip.
- The protection used for the line from Stolle to East Stolle will require A and B line differentials with diverse fiber cables. This will require identical SEL and GE relays to be used for the A and B line diff systems at each end of the line as well as same for any additional associated communications equipment for direct transformer trip needed.
- The protection used for the line from Dysinger to East Stolle should meet similar standards to that for other comparable lines.

3. NUF Estimated Total Costs

Description	Estimated Cost
Transmission Interconnections at Dysinger	\$4,444,000
Transmission Interconnections at Stolle Rd.	\$1,774,000
Upgrade Line Protection Systems at Somerset/Kintigh	\$938,000
Upgrade Line Protection Systems at Stolle Road	\$641,000
Upgrade Erie St. 115 kV Terminal	\$1,067,000
Upgrade Stolle Rd. 115 kV Terminal	\$541,000
Total	\$9,405,000

4. Security

The total amount of Security is \$3,000,000. Within 30 calendar days of the execution of this Agreement, Transmission Developer shall provide security to the Connecting Transmission Owner in the form of a parental guarantee in the amount of \$2,700,000 pursuant to Article 11.4 of this Agreement for the Connecting Transmission Owner's Network Upgrade Facilities. The Transmission Developer has already paid \$300,000 towards the total Security amount under the Utility Service Agreement between the Connecting Transmission Owner and Transmission Developer. Thus, the remaining value of the security is in the amount of \$2,700,000 and shall be secured in the form of a parental guarantee. The Security shall be reduced on a dollar-for-dollar basis for payments made to Connecting Transmission Owner via the Utility Service Agreement.

Figure A-1

[CONTAINS CEII – THIS FIGURE REMOVED FROM PUBLIC VERSION]

Figure A-2

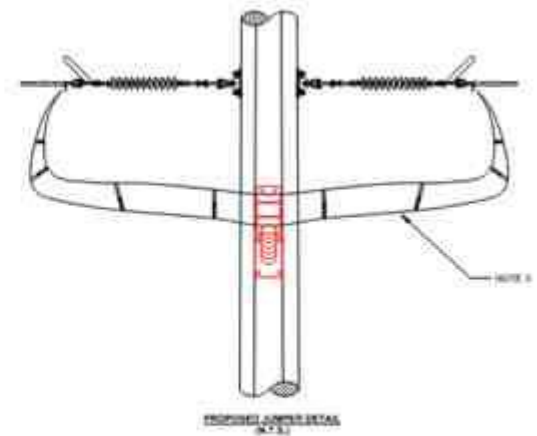
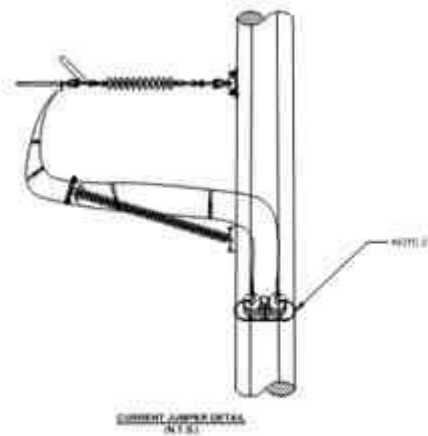
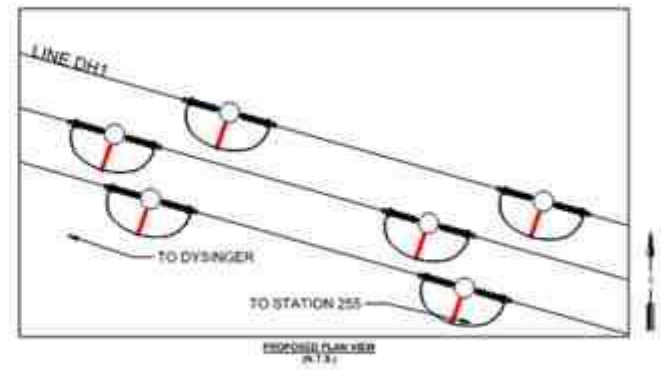
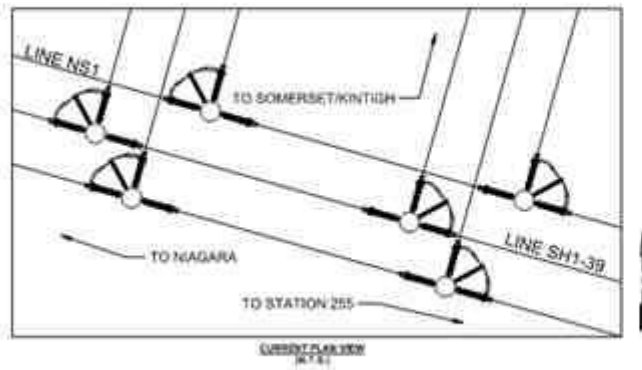

NOTES:

1. CURRENT SHOWS SCAMISSET TAP IN CURRENT CONFIGURATION
2. REMOVE ALL CONDUCTORS TO EXISTING NYSEG STRUCTURES, INSULATORS AND ASSOCIATED HARDWARE
3. INSTALL JUMPER CONDUCTORS, POST AND ASSOCIATED HARDWARE

PRELIMINARY
NOT FOR CONSTRUCTION

APPENDIX B
MILESTONES

Task Name	Finish Date	Responsible Party
Execute Interconnect Agreement		
Upgrading the Erie St. 115 kV Substation Terminal to Depew		
Preliminary Engineering (30% Design, Review, and Approval)	Complete	
Semi-detailed engineering (70% design, review, and approval)	Complete	Connecting Transmission Owner Review
Ratings and Modelling (RAM) draft submittal	Complete	Transmission Developer
Ratings/Modelling (RAM) Final Submittal	June 2021	Transmission Developer
Detailed engineering (90% design, review, and approval)	July 2021	Connecting Transmission Owner Review
Engineering (100% design, review, and approval)	July 2021	Connecting Transmission Owner Review
Transmission Developer procurement	July 2021	Transmission Developer
Relay and SCADA configuration and settings (System Protection and Control 3 – 7) review, and approval	July 2021	Developed by Connecting Transmission Owner
Transmission Developer construction RFP & contract execution	July 2021	Connecting Transmission Owner Review
Connecting Transmission Owner file Article VII amendments	July 2021	Connecting Transmission Owner
Begin construction	September 2021	Transmission Developer
Complete construction	December 2021	
Primary equipment testing and commissioning	December 2021	Transmission Developer
Protection and control testing & commissioning	December 2021	Connecting Transmission Owner
Connecting Transmission Owner As Built drawings review	January 2022	Connecting Transmission Owner
Initial Synchronization Date	February 2022	Transmission Developer
In-Service Date	February 2022	Connecting Transmission Owner
Upgrading the Stolle Road to Roll Road 115 kV Terminal Equipment		

Task Name	Finish Date	Responsible Party
Preliminary engineering (30% design, review, and approval)	Complete	Connecting Transmission Owner Review
Semi-detailed engineering (70% design, review, and approval)	Complete	Connecting Transmission Owner Review
Ratings and Modelling (RAM) draft submittal	Complete	Transmission Developer
Ratings and Modeling (RAM) Final submittal	June 2021	Transmission Developer
Detailed engineering (90% design, review, and approval)	June 2021	Connecting Transmission Owner Review
Engineering (100% design, review, and approval)	July 2021	Connecting Transmission Owner Review
Transmission Developer procurement	July 2021	Transmission Developer
Relay and SCADA configuration and settings (System Protection and Control 3 – 7) review, and approval	July 2021	Developed by Connecting Transmission Owner
Transmission Developer construction RFP & contract execution	July 2021	Connecting Transmission Owner Review
Connecting Transmission Owner file Article VII amendments with DPS	September 2021	Connecting Transmission Owner
Begin construction	September 2021	Transmission Developer
Complete construction	October 2021	Transmission Developer
Connecting Transmission Owner As Built drawings review	January 2022	Connecting Transmission Owner
Protection and control testing & commissioning	February 2022	Connecting Transmission Owner
Initial Synchronization Date	February 2022	Transmission Developer
In-Service Date	February 2022	Connecting Transmission Owner
Upgrading Line Protection Systems at Somerset/Kintigh Substation		
Preliminary engineering (30% design, review, and approval)	Complete	Connecting Transmission Owner Review
Semi-detailed engineering (70% design, review, and approval)	Complete	Connecting Transmission Owner Review
Ratings and Modelling (RAM) draft submittal	Complete	Transmission Developer
Ratings and Modelling (RAM) final submittal	August 2021	Transmission Developer

Task Name	Finish Date	Responsible Party
Detailed engineering (90% design, review, and approval)	August 2021	Connecting Transmission Owner Review
Engineering (100% design, review, and approval)	September 2021	Connecting Transmission Owner Review
Relay and SCADA configuration and settings (System Protection and Control 3 – 7) review, and approval	July 2021	Connecting Transmission Owner
Transmission Developer procurement	July 2021	Transmission Developer
Transmission Developer construction RFP & contract execution	September 2021	Connecting Transmission Owner Review
Connecting Transmission Owner file Article VII amendments with DPS	September 2021	Connecting Transmission Owner
Complete construction (3 new relay panels)	December 2021	Transmission Developer
Connecting Transmission Owner As Built drawings review	January 2022	Connecting Transmission Owner
Protection and control testing & commissioning	February 2022	Connecting Transmission Owner
Initial Synchronization Date	February 2022	Transmission Developer
In-Service Date	February 2022	Connecting Transmission Owner
Upgrading Line Protection Systems at Stolle Road		
Preliminary engineering (30% design, review, and approval)	Complete	Connecting Transmission Owner Review
Semi-detailed engineering (70% design, review, and approval)	Complete	Connecting Transmission Owner Review
Ratings and Modelling (RAM) draft submittal	Complete	Transmission Developer
Detailed engineering (90% design, review, and approval)	June 2021	Connecting Transmission Owner Review
Ratings and Modelling (RAM) final submittal	June 2021	Transmission Developer
Engineering (100% design, review, and approval)	August 2021	Connecting Transmission Owner Review
Transmission Developer procurement	July 2021	Transmission Developer
Relay and SCADA configuration and settings (System Protection and Control 3 – 7) review, and approval	July 2021	Connecting Transmission Owner
Transmission Developer construction RFP & contract execution	July 2021	Connecting Transmission Owner Review

Task Name	Finish Date	Responsible Party
Connecting Transmission Owner file A7 amendments with DPS	August 2021	Connecting Transmission Owner
Complete construction	April 2022	Transmission Developer
Protection and control testing & commissioning	April 2022	Connecting Transmission Owner
Connecting Transmission Owner As Built drawings review	April 2022	Connecting Transmission Owner
Initial Synchronization Date	April 2022	Transmission Developer
In-Service Date	April 2022	Connecting Transmission Owner
Connecting Two Connecting Transmission Owner 345kV Lines #38 and #39 into New Transmission Project 345 kV Dysinger Substation		
Preliminary engineering (30% design, review, and approval)	Complete	Connecting Transmission Owner Review
Semi-detailed engineering (70% design, review, and approval)	Complete	Connecting Transmission Owner Review
Ratings and Modelling (RAM) draft submittal	Complete	Transmission Developer
Transmission Developer Procurement	Complete	Transmission Developer
Transmission Developer construction RFP & contract execution	August 2021	Connecting Transmission Owner Review
Detailed engineering (90% design, review, and approval)	August 2021	Connecting Transmission Owner Review
Connecting Transmission Owner file Article VII amendments with DPS	July 2021	Connecting Transmission Owner
Ratings and Modelling (RAM) final submittal	August 2021	Transmission Developer
Engineering (100% design, review, and approval)	October 2021	Connecting Transmission Owner Review
Connecting Transmission Owner As Built drawings review	May 2022	Connecting Transmission Owner
Testing & commissioning	March 2022	Transmission Developer
Initial Synchronization Date	March 2022	Transmission Developer
In-Service Date	March 2022	Connecting Transmission Owner

Task Name	Finish Date	Responsible Party
Connecting the Connecting Transmission Owner-owned Stolle Rd. to Five Mile 345 kV Line #29 into East Stolle Rd. Substation		
Preliminary engineering (30% design, review, and approval)	Complete	Connecting Transmission Owner Review
Semi-detailed engineering (70% design, review, and approval)	Complete	Connecting Transmission Owner Review
Ratings and Modelling (RAM) draft submittal	Complete	Transmission Developer
Detailed engineering (90% design, review, and approval)	June 2021	Connecting Transmission Owner Review
Connecting Transmission Owner file Article VII amendments with DPS	July 2021	Connecting Transmission Owner
Ratings and Modelling (RAM) final submittal	July 2021	Transmission Developer
Engineering (100% design, review, and approval)	July 2021	Connecting Transmission Owner Review
Transmission Developer construction RFP & contract execution	August 2021	Connecting Transmission Owner Review
Complete Construction (3 new relay panels)	April 2022	Transmission Developer
Connecting Transmission Owner As Built drawings review	March 2022	Connecting Transmission Owner
Testing & commissioning	March 2022	Transmission Developer and Connecting Transmission Owner
Initial Synchronization Date	April 2022	Transmission Developer
In-Service Date	April 2022	Connecting Transmission Owner
Turn Over Facilities (all)	April 2022	Transmission Developer
Transmission Project: testing and commissioning	April 2022	Transmission Developer and Connecting Transmission Owner
Transmission Project: Initial Synchronization Date	April 2022	Transmission Developer
Transmission Project: In-Service Date	April 2022	Transmission Developer
Required In Service Date	June 2022	

APPENDIX C

INTERCONNECTION DETAILS

1. Description of the Transmission Project

The Transmission Project was submitted by the Transmission Developer and evaluated in the NYISO's Public Policy Transmission Planning Process to address the Western New York Public Policy Transmission Need identified by the New York Public Service Commission. The NYISO Board of Directors selected the Transmission Project as the more efficient and cost-effective transmission solution to the Western New York Public Policy Transmission Need on October 17, 2017. The Transmission Developer will develop the Transmission Project in accordance with the terms of the Development Agreement.

The Transmission Project will be located in the West Region (Zone A) of New York State and includes the following new facilities that will be constructed, owned, and operated by the Transmission Developer:

- The proposed Q#545A's Dysinger 345 kV switchyard with a breaker-and-a-half configuration, located in Niagara County;
- The proposed Q#545A's East Stolle Rd. 345 kV switchyard with a ring-bus configuration, located in Erie County;
- A new overhead ("OH") 20.5 mile long 345 kV transmission line between Dysinger and East Stolle Rd. substations, which line: (i) will be a double bundle of 795MCM 26/7 ACSR conductor and rated 1357/1410/1410 MVA, and will be constructed utilizing the existing transmission right-of-way owned by Connecting Transmission Owner;
- In addition to proposed OH construction, the line will consist of approximately 2,000 lf underground construction at New York State Thruway Authority ("NYSTA") crossing. This conductor shall be rated at 3000 Amps (maximum) and consists of 5000 kcmil XLPE cable.
- A new OH 345 kV transmission line of approximately 1,000 feet between new East Stolle Rd. and Stolle Rd. substations;
- A 700 MVA phase angle regulator ("PAR") and bypass switch at the new Dysinger 345 kV switchyard to control the flow of the new proposed line; and
- A 30 MVAR shunt reactor on the proposed 345 kV line at the East Stolle Rd. 345 kV substation.

2. Description of the Points of Interconnection and Points of Change of Ownership

The Point of Interconnection ("POI") and Point of Change in Ownership ("POC") are identified in the table below. The physical POI/POC shall be where the transmission line insulators attach to the structure and where the jumper pad attaches to the Transmission Owners hardware. The POI/POC are also shown in Figure C-1 below. The POI and POC are the same location since the Transmission Project will not require any Connecting Transmission Owner Attachment Facilities. The POI/POC locations are:

Transmission Line	Line # Designation	Structure Number where POI/POC Is Located	Structure Description where POI/POC Is Located	Description of Change in Ownership
Dysinger to Kintigh	38	D-S2-2	First structure in Connecting Transmission Owner's ROW	Connecting Transmission Owner ownership begins from the insulator of the structure and continues to Kintigh
Dysinger to Kintigh	39	D-S1-2	First structure in Connecting Transmission Owner's ROW	Connecting Transmission Owner ownership begins from the insulator of the structure and continues to Kintigh
E. Stolle to Five Mile	29	ES-H-1	First structure outside of East Stolle switchyard	Transmission Developer ownership will begin at the insulators, and go into the East Stolle Switchyard.
E. Stolle to Stolle	28	ES-S-1	First structure outside of East Stolle switchyard	Transmission Developer ownership will begin at the insulators, and go into the East Stolle Switchyard.

FIGURE C-1

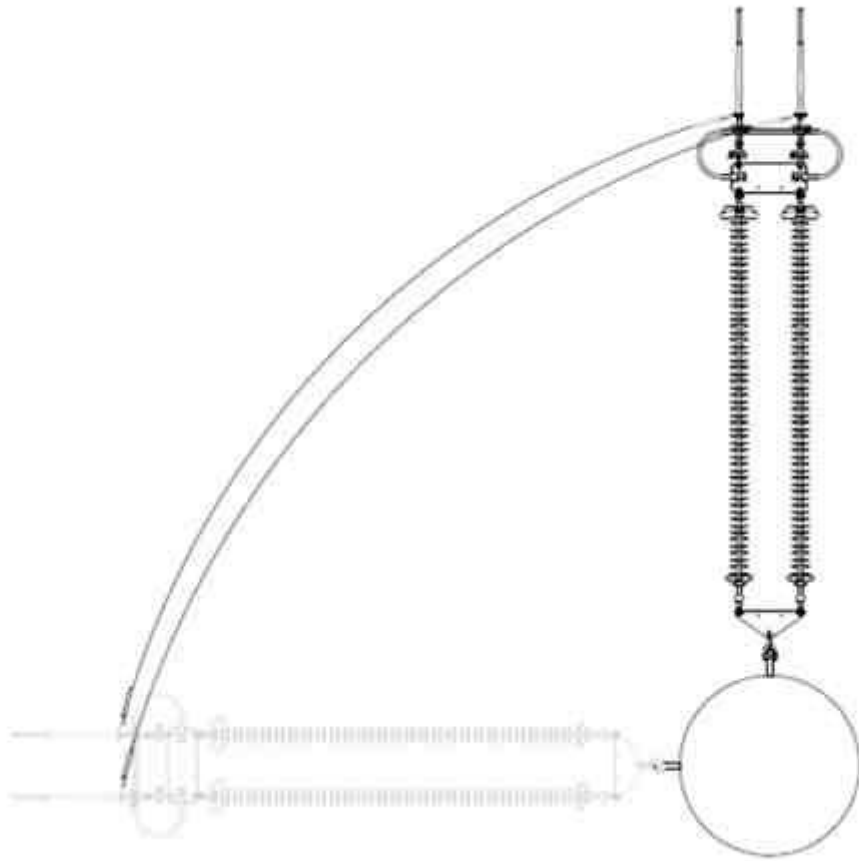

Transmission Developer: BLACK
Connecting Transmission Owner: GREY

3. Ownership/Control/Maintenance Responsibilities of Network Upgrade Facilities

Network Upgrade Facility	Appendix A item	Ownership	Control	Operation & Maintenance
<i>Upgrading the Erie St. 115 kV Substation Terminal to Depew</i>	1.A.i	Connecting Transmission Owner	Connecting Transmission Owner	Connecting Transmission Owner
<i>Upgrading the Stolle Road to Roll Road 115 kV Terminal Equipment</i>	1.A.ii	Connecting Transmission Owner	Connecting Transmission Owner	Connecting Transmission Owner
<i>Upgrading Line Protection Systems at Somerset/Kintigh Substation</i>	1.A.iii	Connecting Transmission Owner	Connecting Transmission Owner	Connecting Transmission Owner
<i>Upgrading Line Protection Systems at Stolle Road</i>	1.A.iv	Connecting Transmission Owner	Connecting Transmission Owner	Connecting Transmission Owner

Network Upgrade Facility	Appendix A item	Ownership	Control	Operation & Maintenance
<i>Connecting Two Connecting Transmission Owner 345kV Lines #38 and #39 into New Transmission Project 345 kV Dysinger Substation</i>	1.A.v	Transmission Developer	Transmission Developer/Connecting Transmission Owner	Transmission Developer
<i>Connecting the Connecting Transmission Owner-owned Stolle Rd. to Five Mile 345 kV Line #29 into East Stolle Rd. Substation</i>	1.A.vi	Connecting Transmission Owner	Transmission Developer/Connecting Transmission Owner	Connecting Transmission Owner

4. Transmission Developer Operating Requirements

(a) Transmission Developer must comply with all applicable NYISO tariffs and procedures, as amended from time to time.

(b) Transmission Developer and Connecting Transmission Owner must comply with each other’s operating instructions and requirements, as amended from time to time, to the extent not inconsistent with the terms of this Agreement or the NYISO OATT.

APPENDIX D

SECURITY ARRANGEMENTS DETAILS

Infrastructure security of New York State Transmission System equipment and operations and control hardware and software is essential to ensure day-to-day New York State Transmission System reliability and operational security. The Commission will expect the NYISO, all Transmission Owners, all Transmission Developers and all other Market Participants to comply with the recommendations offered by the President's Critical Infrastructure Protection Board and, eventually, best practice recommendations from the electric reliability authority. All public utilities will be expected to meet basic standards for system infrastructure and operational security, including physical, operational, and cyber-security practices.

APPENDIX E-1

INITIAL SYNCHRONIZATION DATE

[Date]

New York Independent System Operator, Inc.
Attn: Vice President, Operations
10 Krey Boulevard
Rensselaer, NY 12144

New York State Electric & Gas Corporation
Attn: Manager-Programs/Projects
Electric Transmission Services
PO Box 5224
Binghamton, NY 13902-5224

Re: _____ [Transmission Project/Network Upgrade Facilities]

Dear _____:

On [Date] [Transmission Developer] initially synchronized the [describe Transmission Project/Network Upgrade Facilities]. This letter confirms [Transmission Developer]'s Initial Synchronization Date was [specify].

Thank you.

[Signature]

[Transmission Developer Representative]

APPENDIX E-2

IN-SERVICE DATE

[Date]

New York Independent System Operator, Inc.
Attn: Vice President, Operations
10 Krey Boulevard
Rensselaer, NY 12144

New York State Electric & Gas Corporation
Attn: Manager-Programs/Projects
Electric Transmission Services
PO Box 5224
Binghamton, NY 13902-5224

Re: _____ [Transmission Project/Network Upgrade Facilities]

Dear _____:

On [Date] [Transmission Developer] has completed Trial Operation of [describe Transmission Project/Network Upgrade Facilities]. This letter confirms that [describe Transmission Project/Network Upgrade Facilities] [has/have] commenced service, effective as of [Date plus one day].

Thank you.

[Signature]

[Transmission Developer Representative]

APPENDIX F

ADDRESSES FOR DELIVERY OF NOTICES AND BILLINGS

Notices:

NYISO:

Before In-Service Date of Transmission Project:

New York Independent System Operator, Inc.
Attn: Vice President, System and Resource Planning
10 Krey Boulevard
Rensselaer, NY 12144
Phone: (518) 356-6000
Fax: (518) 356-6118

After In-Service Date of Transmission Project:

New York Independent System Operator, Inc.
Attn: Vice President, Operations
10 Krey Boulevard
Rensselaer, NY 12144
Phone: (518) 356-6000
Fax: (518) 356-6118

Connecting Transmission Owner:

New York State Electric & Gas Corporation
Attn: Manager-Programs/Projects
Electric Transmission Services
PO Box 5224
Binghamton, NY 13902-5224
Phone: (585) 484-6306
J_mahoney@nyseg.com
NYISOInterconnectionAdmin@Avangrid.com

Transmission Developer:

NextEra Energy Transmission New York, Inc.
Attn: Director of NY Development
700 Universe Boulevard
UST-C5666
Juno Beach, FL 34408

Billings and Payments:

Connecting Transmission Owner:

New York State Electric & Gas Corporation
Attn: Mgr. Billing & Risk Management
PO Box 5224
Binghamton, NY 13902-5224
Phone: (585) 484-6883
Fax: (607) 762-8885

Transmission Developer:

NextEra Energy Transmission New York, Inc.
Attn: Director of NY Development
700 Universe Boulevard
UST-C5666
Juno Beach, FL 34408

Alternative Forms of Delivery of Notices (telephone, facsimile or email):

NYISO:

Before In-Service Date of Transmission Project:

New York Independent System Operator, Inc.
Attn: Vice President, System and Resource Planning
10 Krey Boulevard
Rensselaer, NY 12144
Phone: (518) 356-6000
Fax: (518) 356-6118
E-mail: interconnectionsupport@nyiso.com

After In-Service Date of Transmission Project:

New York Independent System Operator, Inc.
Attn: Vice President, Operations
10 Krey Boulevard
Rensselaer, NY 12144
Phone: (518) 356-6000
Fax: (518) 356-6118
E-mail: interconnectionsupport@nyiso.com

Connecting Transmission Owner:

New York State Electric & Gas Corporation

Attn: Manager-Programs/Projects
Electric Transmission Services
PO Box 5224
Binghamton, NY 13902-5224
Phone: (585) 484-6306
J_mahoney@nyseg.com
NYISOInterconnectionAdmin@Avangrid.com

Transmission Developer:

NextEra Energy Transmission New York, Inc.
Attn: Director of NY Development
700 Universe Boulevard
UST-C5666
Juno Beach, FL 34408
Phone: (561) 694-4831
Johnbinh.vu@nexteraenergy.com
info@empirestateline.com