

SERVICE AGREEMENT NO. 1168

**SECOND AMENDED AND RESTATED SMALL GENERATOR
INTERCONNECTION AGREEMENT**

by and among

NEW YORK INDEPENDENT SYSTEM OPERATOR, INC.,

NIAGARA MOHAWK POWER CORPORATION D/B/A NATIONAL GRID,

and

ALBANY ENERGY LLC

(ALBANY LANDFILL PROJECT)

Dated as of October 19, 2012

TABLE OF CONTENTS

	Page No.
Article 1. Scope and Limitations of Agreement	3
1.1 Applicability	3
1.2 Purpose.....	3
1.3 Scope of Interconnection Service	3
1.4 Limitations	3
1.5 Responsibilities of the Parties.....	3
1.6 Parallel Operation Obligations.....	4
1.7 Metering.....	5
1.8 Reactive Power	5
1.9 Capitalized Terms	5
Article 2. Inspection, Testing, Authorization, and Right of Access	6
2.1 Equipment Testing and Inspection.....	6
2.2 Authorization Required Prior to Parallel Operation	6
2.3 Right of Access	7
Article 3. Effective Date, Term, Termination, and Disconnection	8
3.1 Effective Date	8
3.2 Term of Agreement.....	8
3.3 Termination.....	8
3.4 Temporary Disconnection.....	9
Article 4. Cost Responsibility for Interconnection Facilities and Distribution Upgrades	11
4.1 Interconnection Facilities.....	11
4.2 Distribution Upgrades.....	11
Article 5. Cost Responsibility for System Upgrade Facilities and System Deliverability Upgrades	12
5.1 Applicability	12

5.2	System Upgrades	12
5.3	Special Provisions for Affected Systems	12
Article 6.	Billing, Payment, Milestones, and Financial Security	13
6.1	Billing and Payment Procedures and Financial Accounting.....	13
6.2	Milestones	13
6.3	Financial Security Arrangements.....	14
Article 7	Assignment, Liability, Indemnity, Force Majeure, Consequential Damages, and Default	15
7.1	Assignment	15
7.2	Limitation of Liability	15
7.3	Indemnity	15
7.4	Consequential Damages.....	16
7.5	Force Majeure	17
7.6	Breach and Default	17
Article 8	Insurance.....	19
Article 9.	Confidentiality	20
Article 10.	Disputes	22
Article 11.	Taxes.....	23
Article 12.	Miscellaneous	24
12.1	Governing Law, Regulatory Authority, and Rules	24
12.2	Amendment.....	24
12.3	No Third-Party Beneficiaries.....	24
12.4	Waiver.....	24
12.5	Entire Agreement.....	24
12.6	Multiple Counterparts	25
12.7	No Partnership	25

12.8	Severability	25
12.9	Security Arrangements	25
12.10	Environmental Releases.....	25
12.11	Subcontractors	26
12.12	Reservation of Rights.....	26
Article 13.	Notices	27
13.1	General.....	27
13.2	Billing and Payment.....	28
13.3	Alternative Forms of Notice	28
13.4	Designated Operating Representative.....	29
13.5	Changes to the Notice Information	30
Article 14.	Signatures.....	31
Attachment 1	Glossary of Terms.....	1-1
Attachment 2	Detailed Scope of Work, Including Description and Costs of the Small Generating Facility, Interconnection Facilities, and Metering Equipment	2-1
Attachment 3	One-line Diagram Depicting the Small Generating Facility, Interconnection Facilities, Metering Equipment, and Upgrades.....	3-1
Attachment 4	Milestones.....	4-1
Attachment 5	Additional Operating Requirements for the New York State Transmission System, the Distribution System and Affected Systems Needed to Support the Interconnection Customer’s Needs	5-1
Attachment 6	Connecting Transmission Owner’s Description of its Upgrades and Best Estimate of Upgrade Costs.....	6-1
Attachment 7	Insurance Coverage.....	7-1

**SECOND AMENDED AND RESTATED SMALL GENERATOR INTERCONNECTION
AGREEMENT**

This Second Amended and Restated Interconnection Agreement (“Agreement”) is made and entered into this 19th day of October, 2012, by and among the New York Independent System Operator, Inc., a not-for-profit corporation organized and existing under the laws of the State of New York (“NYISO”) and Niagara Mohawk Power Corporation, d/b/a National Grid, a corporation existing under the laws of the State of New York (“Connecting Transmission Owner”), and Albany Energy LLC, a limited liability company organized and existing under the laws of the State of Delaware (“Interconnection Customer”) each hereinafter sometimes referred to individually as “Party” or referred to collectively as the “Parties.”

NYISO Information

Before commercial operation of the Large Generating Facility:

New York Independent System Operator, Inc.
Attention: Vice President, System and Resource Planning
10 Krey Boulevard
Rensselaer, NY 12144
Phone: (518) 356-6000
Fax: (518) 356-6118

After commercial operation of the Large Generating Facility

New York Independent System Operator, Inc.
Attention: Vice President, Operations
3890 Carman Road
Schenectady, NY 12303
Phone: (518) 356-6000
Fax: (518) 356-6118

Connecting Transmission Owner Information

Niagara Mohawk Power Corporation d/b/a National Grid
Attention: Director, Transmission Commercial Services
40 Sylvan Road

Waltham, MA 02451-1120

Phone: (781) 907-2422

Fax: (315) 428-5114

Interconnection Customer Information

Albany Energy LLC

Attention: General Manager

5087 Junction Road

Lockport, NY 14094-9601

Phone: (716) 439-1004

Fax: (716) 439-1000

Interconnection Customer Application No: _____ N/A _____

In consideration of the mutual covenants set forth herein, the Parties agree as follows:

ARTICLE 1
SCOPE AND LIMITATIONS OF AGREEMENT

1.1 Applicability

This Amended and Restated Small Generator Interconnection Agreement (“Agreement” or SGIA”) shall be used for all Interconnection Requests submitted under the Small Generator Interconnection Procedures (SGIP) except for those submitted under the 10 kW Inverter Process contained in SGIP Attachment 5.

1.2 Purpose

This Agreement governs the terms and conditions under which the Interconnection Customer's Small Generating Facility will interconnect with, and operate in parallel with, the New York State Transmission System or the Distribution System.

1.3 Scope of Interconnection Service

- 1.3.1 NYISO will provide Energy Resource Interconnection Service and Capacity Resource Interconnection Service to Interconnection Customer at the Point of Interconnection, with Capacity Resource Interconnection Service subject to the provisions set forth in Attachment 5.
- 1.3.2 This Agreement does not constitute an agreement to purchase or deliver the Interconnection Customer's power. The purchase or delivery of power and other services that the Interconnection Customer may require will be covered under separate agreements, if any, or applicable provisions of NYISO's or Connecting Transmission Owner's tariffs. The Interconnection Customer will be responsible for separately making all necessary arrangements (including scheduling) for delivery of electricity in accordance with the applicable provisions of the NYISO OATT and Connecting Transmission Owner's tariff. The execution of this Agreement does not constitute a request for, nor agreement to, provide energy, any Ancillary Services or Installed Capacity under the NYISO Services Tariff or any Connecting Transmission Owner's tariff. If Interconnection Customer wishes to supply or purchase energy, Installed Capacity or Ancillary Services, then Interconnection Customer will make application to do so in accordance with the NYISO Services Tariff or Connecting Transmission Owner's tariff.

1.4 Limitations

Nothing in this Agreement is intended to affect any other agreement by and among the NYISO, Connecting Transmission Owner and the Interconnection Customer, except as otherwise expressly provided herein.

1.5 Responsibilities of the Parties

- 1.5.1 The Parties shall perform all obligations of this Agreement in accordance with all Applicable Laws and Regulations, Operating Requirements, and Good Utility Practice.
- 1.5.2 The Interconnection Customer shall construct, interconnect, operate and maintain its Small Generating Facility and construct, operate, and maintain its Interconnection Facilities in accordance with the applicable manufacturer's recommended maintenance schedule, and in accordance with this Agreement, and with Good Utility Practice.
- 1.5.3 The Connecting Transmission Owner shall construct, operate, and maintain its Interconnection Facilities and Upgrades covered by this Agreement in accordance with this Agreement, and with Good Utility Practice.
- 1.5.4 The Interconnection Customer agrees to construct its facilities or systems in accordance with applicable specifications that meet or exceed those provided by the National Electrical Safety Code, the American National Standards Institute, IEEE, Underwriter's Laboratory, and Operating Requirements in effect at the time of construction and other applicable national and state codes and standards. The Interconnection Customer agrees to design, install, maintain, and operate its Small Generating Facility so as to reasonably minimize the likelihood of a disturbance adversely affecting or impairing the system or equipment of the Connecting Transmission Owner or Affected Systems.
- 1.5.5 The Connecting Transmission Owner and Interconnection Customer shall operate, maintain, repair, and inspect, and shall be fully responsible for the facilities that it now or subsequently may own unless otherwise specified in the Attachments to this Agreement. Each of those Parties shall be responsible for the safe installation, maintenance, repair and condition of their respective lines and appurtenances on their respective sides of the point of change of ownership. The Connecting Transmission Owner and the Interconnection Customer, as appropriate, shall provide Interconnection Facilities that adequately protect the Connecting Transmission Owner's electric system, personnel, and other persons from damage and injury. The allocation of responsibility for the design, installation, operation, maintenance and ownership of Interconnection Facilities shall be delineated in the Attachments to this Agreement.
- 1.5.6 The NYISO shall coordinate with all Affected Systems to support the interconnection. The Connecting Transmission Owner shall cooperate with the NYISO in these efforts.

1.6 Parallel Operation Obligations

Once the Small Generating Facility has been authorized to commence parallel operation, the Interconnection Customer shall abide by all rules and procedures pertaining to the parallel operation of the Small Generating Facility in the applicable control area, including, but not limited to; (1) the rules and procedures concerning the operation of generation set forth in the NYISO tariffs or ISO Procedures or the Connecting Transmission Owner's tariff; (2) any requirements consistent with Good Utility Practice or that are necessary to ensure the safe and reliable operation of the Transmission System or Distribution System; and (3) the Operating Requirements set forth in Attachment 5 of this Agreement.

1.7 Metering

The Interconnection Customer shall be responsible for the Connecting Transmission Owner's reasonable and necessary cost for the purchase, installation, operation, maintenance, testing, repair, and replacement of metering and data acquisition equipment specified in Attachments 2 and 3 of this Agreement. The Interconnection Customer's metering (and data acquisition, as required) equipment shall conform to applicable industry rules and Operating Requirements.

1.8 Reactive Power

- 1.8.1 The Interconnection Customer shall design its Small Generating Facility to maintain a composite power delivery at continuous rated power output at the Point of Interconnection at a power factor within the range established by the Connecting Transmission Owner on a comparable basis, until NYISO has established different requirements that apply to all similarly situated generators in the New York Control Area on a comparable basis.
- 1.8.2 The NYISO is required to pay the Interconnection Customer for reactive power, or voltage support service, that the Interconnection Customer provides from the Small Generating Facility in accordance with Rate Schedule 2 of the NYISO Services Tariff.

1.9 Capitalized Terms

Capitalized terms used herein shall have the meanings specified in the Glossary of Terms in Attachment 1 or the body of this Agreement. Capitalized terms used herein that are not so defined shall have the meanings specified in Section 32.1.0 or Attachment S or Attachment X of the NYISO OATT.

ARTICLE 2

INSPECTION, TESTING, AUTHORIZATION, AND RIGHT OF ACCESS

2.1 Equipment Testing and Inspection

- 2.1.1 The Interconnection Customer shall test and inspect its Small Generating Facility and Interconnection Facilities prior to interconnection. The Interconnection Customer shall notify the NYISO and the Connecting Transmission Owner of such activities no fewer than five Business Days (or as may be agreed to by the Parties) prior to such testing and inspection. Testing and inspection shall occur on a Business Day. The Connecting Transmission Owner may, at its own expense, send qualified personnel to the Small Generating Facility site to inspect the interconnection and observe the testing. The Interconnection Customer shall provide the NYISO and Connecting Transmission Owner a written test report when such testing and inspection is completed. The Small Generating Facility may not commence parallel operations if the NYISO, in consultation with the Connecting Transmission Owner, finds that the Small Generating Facility has not been installed as agreed upon or may not be operated in a safe and reliable manner.
- 2.1.2 The NYISO and Connecting Transmission Owner shall each provide the Interconnection Customer written acknowledgment that it has received the Interconnection Customer's written test report. Such written acknowledgment shall not be deemed to be or construed as any representation, assurance, guarantee, or warranty by the NYISO or Connecting Transmission Owner of the safety, durability, suitability, or reliability of the Small Generating Facility or any associated control, protective, and safety devices owned or controlled by the Interconnection Customer or the quality of power produced by the Small Generating Facility.

2.2 Authorization Required Prior to Parallel Operation

- 2.2.1 The NYISO, in consultation with the Connecting Transmission Owner, shall use Reasonable Efforts to list applicable parallel Operating Requirements in Attachment 5 of this Agreement. Additionally, the NYISO, in consultation with the Connecting Transmission Owner, shall notify the Interconnection Customer of any changes to these requirements as soon as they are known. The NYISO and Connecting Transmission Owner shall make Reasonable Efforts to cooperate with the Interconnection Customer in meeting requirements necessary for the Interconnection Customer to commence parallel operations by the in-service date.
- 2.2.2 The Interconnection Customer shall not operate its Small Generating Facility in parallel with the New York State Transmission System or the Distribution System without prior written authorization of the NYISO. The NYISO, in consultation with the Connecting Transmission Owner, will provide such authorization once the NYISO receives notification that the Interconnection Customer has complied with all applicable parallel Operating Requirements. Such authorization shall not be unreasonably withheld, conditioned, or delayed.

2.3 Right of Access

- 2.3.1 Upon reasonable notice, the NYISO and/or Connecting Transmission Owner may send a qualified person to the premises of the Interconnection Customer at or immediately before the time the Small Generating Facility first produces energy to inspect the interconnection, and observe the commissioning of the Small Generating Facility (including any required testing), startup, and operation for a period of up to three Business Days after initial start-up of the unit. In addition, the Interconnection Customer

shall notify the NYISO and Connecting Transmission Owner at least five Business Days prior to conducting any on-site verification testing of the Small Generating Facility.

- 2.3.2 Following the initial inspection process described above, at reasonable hours, and upon reasonable notice, or at any time without notice in the event of an emergency or hazardous condition, the NYISO and Connecting Transmission Owner each shall have access to the Interconnection Customer's premises for any reasonable purpose in connection with the performance of the obligations imposed on them by this Agreement or if necessary to meet their legal obligation to provide service to their customers.
- 2.3.3 Each Party shall be responsible for its own costs associated with following this article.

ARTICLE 3

EFFECTIVE DATE, TERM, TERMINATION, AND DISCONNECTION

3.1 Effective Date

This Agreement shall become effective upon execution by the Parties subject to acceptance by FERC (if applicable), or if filed unexecuted, upon the date specified by the FERC. The NYISO and Connecting Transmission Owner shall promptly file, or cause to be filed, this Agreement with FERC upon execution, if required. If the Agreement is disputed and the Interconnection Customer requests that it be filed with FERC in an unexecuted form, the NYISO shall file, or cause to be filed, this Agreement and the NYISO shall identify the disputed language.

3.2 Term of Agreement

This Agreement shall become effective on the Effective Date and shall remain in effect for a period of ten years from the Effective Date or such other longer period as the Interconnection Customer may request and shall be automatically renewed for each successive one-year period thereafter, unless terminated earlier in accordance with article 3.3 of this Agreement.

3.3 Termination

No termination shall become effective until the Parties have complied with all Applicable Laws and Regulations applicable to such termination, including the filing with FERC of a notice of termination of this Agreement (if required), which notice has been accepted for filing by FERC.

- 3.3.1 The Interconnection Customer may terminate this Agreement at any time by giving the NYISO and Connecting Transmission Owner 20 Business Days written notice.
- 3.3.2 Any Party may terminate this Agreement after Default pursuant to article 7.6.
- 3.3.3 Upon termination of this Agreement, the Small Generating Facility will be disconnected from the New York State Transmission System or the Distribution System, as applicable. All costs required to effectuate such disconnection shall be borne by the terminating Party, unless such termination resulted from the non-terminating Party's Default of this SGIA or such non-terminating Party otherwise is responsible for these costs under this SGIA.
- 3.3.4 The termination of this Agreement shall not relieve any Party of its liabilities and obligations, owed or continuing at the time of the termination. The Interconnection Customer shall pay all amounts in excess of any deposit or other security without interest within 30 calendar days after receipt of the invoice for such amounts. If the deposit or other security exceeds the invoice, the Connecting Transmission Owner shall refund such excess within 30 calendar days of the invoice without interest. If the Interconnection Customer disputes an amount to be paid the Interconnection Customer shall pay the disputed amount to the Connecting Transmission Owner or into an interest bearing escrow account, pending resolution of the dispute in accordance with Article 10 of this Agreement. To the extent the dispute is resolved in the Interconnection Customer's favor, that portion of the disputed amount will be returned to the Interconnection Customer with interest at rates applicable to refunds under the Commission's regulations. To the extent the dispute is resolved in the Connecting Transmission Owner's favor, that

portion of any escrowed funds and interest will be released to the Connecting Transmission Owner.

- 3.3.5 The limitations of liability, indemnification and confidentiality provisions of this Agreement shall survive termination or expiration of this Agreement.

3.4 Temporary Disconnection

Temporary disconnection shall continue only for so long as reasonably necessary under Good Utility Practice.

3.4.1 Emergency Conditions

“Emergency Condition” shall mean a condition or situation: (1) that in the judgment of the Party making the claim is imminently likely to endanger life or property; or (2) that, in the case of the NYISO or Connecting Transmission Owner, is imminently likely (as determined in a non-discriminatory manner) to cause a material adverse effect on the security of, or damage to the New York State Transmission System or Distribution System, the Connecting Transmission Owner’s Interconnection Facilities or the electric systems of others to which the New York State Transmission System or Distribution System is directly connected; or (3) that, in the case of the Interconnection Customer, is imminently likely (as determined in a non-discriminatory manner) to cause a material adverse effect on the security of, or damage to, the Small Generating Facility or the Interconnection Customer’s Interconnection Facilities. Under Emergency Conditions, the NYISO or Connecting Transmission Owner may immediately suspend interconnection service and temporarily disconnect the Small Generating Facility. The NYISO or Connecting Transmission Owner shall notify the Interconnection Customer promptly when it becomes aware of an Emergency Condition that may reasonably be expected to affect the Interconnection Customer’s operation of the Small Generating Facility. The Interconnection Customer shall notify the NYISO and Connecting Transmission Owner promptly when it becomes aware of an Emergency Condition that may reasonably be expected to affect the New York State Transmission System or Distribution System or any Affected Systems. To the extent information is known, the notification shall describe the Emergency Condition, the extent of the damage or deficiency, the expected effect on the operation of each Party’s facilities and operations, its anticipated duration, and the necessary corrective action.

3.4.2 Routine Maintenance, Construction, and Repair

The NYISO or Connecting Transmission Owner may interrupt interconnection service or curtail the output of the Small Generating Facility and temporarily disconnect the Small Generating Facility from the New York State Transmission System or Distribution System when necessary for routine maintenance, construction, and repairs on the New York State Transmission System or Distribution System. NYISO or the Connecting Transmission Owner shall provide the Interconnection Customer with five Business Days notice prior to such interruption. The NYISO and Connecting Transmission Owner shall use Reasonable Efforts to coordinate such reduction or temporary disconnection with the Interconnection Customer.

3.4.3 Forced Outages

During any forced outage, the NYISO or Connecting Transmission Owner may suspend interconnection service to the Interconnection Customer to effect immediate repairs on the New York

State Transmission System or the Distribution System. The NYISO shall use Reasonable Efforts to provide the Interconnection Customer with prior notice. If prior notice is not given, the NYISO shall, upon request, provide the Interconnection Customer written documentation after the fact explaining the circumstances of the disconnection.

3.4.4 Adverse Operating Effects

The NYISO or Connecting Transmission Owner shall notify the Interconnection Customer as soon as practicable if, based on Good Utility Practice, operation of the Small Generating Facility may cause disruption or deterioration of service to other customers served from the same electric system, or if operating the Small Generating Facility could cause damage to the New York State Transmission System, the Distribution System or Affected Systems, or if disconnection is otherwise required under Applicable Reliability Standards or the NYISO OATT. Supporting documentation used to reach the decision to disconnect shall be provided to the Interconnection Customer upon request. If, after notice, the Interconnection Customer fails to remedy the adverse operating effect within a reasonable time, the NYISO or Connecting Transmission Owner may disconnect the Small Generating Facility. The NYISO or Connecting Transmission Owner shall provide the Interconnection Customer with five Business Day notice of such disconnection, unless the provisions of article 3.4.1 apply.

3.4.5 Modification of the Small Generating Facility

The Interconnection Customer must receive written authorization from the NYISO and Connecting Transmission Owner before making any change to the Small Generating Facility that may have a material impact on the safety or reliability of the New York State Transmission System or the Distribution System. Such authorization shall not be unreasonably withheld. Modifications shall be done in accordance with Good Utility Practice. If the Interconnection Customer makes such modification without the prior written authorization of the NYISO and Connecting Transmission Owner, the Connecting Transmission Owner shall have the right to temporarily disconnect the Small Generating Facility. If disconnected, the Small Generating Facility will not be reconnected until the unauthorized modifications are authorized or removed.

3.4.6 Reconnection

The Parties shall cooperate with each other to restore the Small Generating Facility, Interconnection Facilities, and the New York State Transmission System and Distribution System to their normal operating state as soon as reasonably practicable following a temporary disconnection.

ARTICLE 4

**COST RESPONSIBILITY FOR INTERCONNECTION FACILITIES
AND DISTRIBUTION UPGRADES**

4.1 Interconnection Facilities

- 4.1.1 The Interconnection Customer shall pay for the cost of the Interconnection Facilities itemized in Attachment 2 of this Agreement. The NYISO, in consultation with the Connecting Transmission Owner, shall provide a best estimate cost, including overheads, for the purchase and construction of its Interconnection Facilities and provide a detailed itemization of such costs. Costs associated with Interconnection Facilities may be shared with other entities that may benefit from such facilities by agreement of the Interconnection Customer, such other entities, the NYISO, and the Connecting Transmission Owner.
- 4.1.2 The Interconnection Customer shall be responsible for its share of all reasonable expenses, including overheads, associated with (1) owning, operating, maintaining, repairing, and replacing its own Interconnection Facilities, and (2) operating, maintaining, repairing, and replacing the Connecting Transmission Owner's Interconnection Facilities, as set forth in Attachment 2 to this Agreement.

4.2 Distribution Upgrades

The Connecting Transmission Owner shall design, procure, construct, install, and own the Distribution Upgrades described in Attachment 6 of this Agreement. If the Connecting Transmission Owner and the Interconnection Customer agree, the Interconnection Customer may construct Distribution Upgrades that are located on land owned by the Interconnection Customer. The actual cost of the Distribution Upgrades, including overheads, shall be directly assigned to the Interconnection Customer. The Interconnection Customer shall be responsible for its share of all reasonable expenses, including overheads, associated with owning, operating, maintaining, repairing, and replacing the Distribution Upgrades, as set forth in Attachment 6 to this Agreement.

ARTICLE 5

**COST RESPONSIBILITY FOR SYSTEM UPGRADE FACILITIES AND SYSTEM
DELIVERABILITY UPGRADES**

5.1 Applicability

No portion of this article 5 shall apply unless the interconnection of the Small Generating Facility requires System Upgrade Facilities or System Deliverability Upgrades.

5.2 System Upgrades

The Connecting Transmission Owner shall procure, construct, install, and own the System Upgrade Facilities and System Deliverability Upgrades described in Attachment 6 of this Agreement. To the extent that design work is necessary in addition to that already accomplished in the Class Year facilities study for the Interconnection Customer, the Connecting Transmission Owner shall perform or cause to be performed such work. If all the Parties agree, the Interconnection Customer may construct System Upgrade Facilities and System Deliverability Upgrades that are located on land owned by the Interconnection Customer.

- 5.2.1 As described in Section 32.3.5.3 of the SGIP in Attachment Z of the NYISO OATT, the responsibility of the Interconnection Customer for the cost of the System Upgrade Facilities and System Deliverability Upgrades described in Attachment 6 of this Agreement shall be determined in accordance with Attachment S of the NYISO OATT, as required by Section 32.3.5.3.2 of Attachment Z. The Interconnection Customer shall be responsible for all System Upgrade Facility costs as required by Section 32.3.5.3.2 of Attachment Z or its share of any System Upgrade Facilities and System Deliverability Upgrades costs resulting from the final Attachment S process, as applicable, and Attachment 6 to this Agreement shall be revised accordingly.
- 5.2.2 Pending the outcome of the Attachment S cost allocation process, if applicable, the Interconnection Customer may elect to proceed with the interconnection of its Small Generating Facility in accordance with Section 32.3.5.3 of the SGIP.

5.3 Special Provisions for Affected Systems

For the repayment of amounts advanced to Affected System Operator for System Upgrade Facilities or System Deliverability Upgrades, the Interconnection Customer and Affected System Operator shall enter into an agreement that provides for such repayment, but only if responsibility for the cost of such System Upgrade Facilities is not to be allocated in accordance with Attachment S of the NYISO OATT. The agreement shall specify the terms governing payments to be made by the Interconnection Customer to Affected System operator as well as the repayment by Affected System Operator.

ARTICLE 6

BILLING, PAYMENT, MILESTONES, AND FINANCIAL SECURITY

6.1 Billing and Payment Procedures and Final Accounting

- 6.1.1 The Connecting Transmission Owner shall bill the Interconnection Customer for the design, engineering, construction, and procurement costs of Interconnection Facilities and Upgrades contemplated by this Agreement on a monthly basis, or as otherwise agreed by those Parties. The Interconnection Customer shall pay all invoice amounts within 30 calendar days after receipt of the invoice.
- 6.1.2 Within three months of completing the construction and installation of the Connecting Transmission Owner's Interconnection Facilities and/or Upgrades described in the Attachments to this Agreement, the Connecting Transmission Owner shall provide the Interconnection Customer with a final accounting report of any difference between (1) the Interconnection Customer's cost responsibility for the actual cost of such facilities or Upgrades, and (2) the Interconnection Customer's previous aggregate payments to the Connecting Transmission Owner for such facilities or Upgrades. If the Interconnection Customer's cost responsibility exceeds its previous aggregate payments, the Connecting Transmission Owner shall invoice the Interconnection Customer for the amount due and the Interconnection Customer shall make payment to the Connecting Transmission Owner within 30 calendar days. If the Interconnection Customer's previous aggregate payments exceed its cost responsibility under this Agreement, the Connecting Transmission Owner shall refund to the Interconnection Customer an amount equal to the difference within 30 calendar days of the final accounting report.
- 6.1.3 If the Interconnection Customer disputes an amount to be paid, the Interconnection Customer shall pay the disputed amount to the Connecting Transmission Owner or into an interest bearing escrow account, pending resolution of the dispute in accordance with Article 10 of this Agreement. To the extent the dispute is resolved in the Interconnection Customer's favor, that portion of the disputed amount will be credited or returned to the Interconnection Customer with interest at rates applicable to refunds under the Commission's regulations. To the extent the dispute is resolved in the Connecting Transmission Owner's favor, that portion of any escrowed funds and interest will be released to the Connecting Transmission Owner.

6.2 Milestones

Subject to the provisions of the SGIP, the Parties shall agree on milestones for which each Party is responsible and list them in Attachment 4 of this Agreement. A Party's obligations under this provision may be extended by agreement. If a Party anticipates that it will be unable to meet a milestone for any reason other than a Force Majeure event, it shall immediately notify the other Parties of the reason(s) for not meeting the milestone and (1) propose the earliest reasonable alternate date by which it can attain this and future milestones, and (2) requesting appropriate amendments to Attachment 4. The Party affected by the failure to meet a milestone shall not unreasonably withhold agreement to such an amendment unless it will suffer significant uncompensated economic or operational harm from the delay, (1) attainment of the same milestone has previously been delayed, or (2) it has reason to believe that the delay in meeting the milestone is intentional or unwarranted notwithstanding the circumstances explained by the Party proposing the amendment.

6.3 Financial Security Arrangements

At least 20 Business Days prior to the commencement of the design, procurement, installation, or construction of a discrete portion of the Connecting Transmission Owner's Interconnection Facilities and Upgrades, the Interconnection Customer shall provide the Connecting Transmission Owner, at the Interconnection Customer's option, a guarantee, a surety bond, letter of credit or other form of security that is reasonably acceptable to the Connecting Transmission Owner and is consistent with the Uniform Commercial Code of the jurisdiction where the Point of Interconnection is located. Such security for payment shall be in an amount sufficient to cover the costs for constructing, designing, procuring, and installing the applicable portion of the Connecting Transmission Owner's Interconnection Facilities and Upgrades and shall be reduced on a dollar-for-dollar basis for payments made to the Connecting Transmission Owner under this Agreement during its term. The Connecting Transmission Owner may draw on any such security to the extent that the Interconnection Customer fails to make any payments due under this Agreement. In addition:

- 6.3.1 The guarantee must be made by an entity that meets the creditworthiness requirements of the Connecting Transmission Owner, and contain terms and conditions that guarantee payment of any amount that may be due from the Interconnection Customer, up to an agreed-to maximum amount.
- 6.3.2 The letter of credit or surety bond must be issued by a financial institution or insurer reasonably acceptable to the Connecting Transmission Owner and must specify a reasonable expiration date.
- 6.3.3 Notwithstanding the above, Security posted for System Upgrade Facilities for a Small Generating Facility required to enter the Class Year process, or cash or Security provided for System Deliverability Upgrades, shall meet the requirements for Security contained in Attachment S to the NYISO OATT.

ARTICLE 7

**ASSIGNMENT, LIABILITY, INDEMNITY, FORCE MAJEURE,
CONSEQUENTIAL DAMAGES, AND DEFAULT**

7.1 Assignment

This Agreement, and each and every term and condition hereof, shall be binding upon and inure to the benefit of the Parties hereto and their respective successors and assigns. This Agreement may be assigned by any Party upon 15 Business Days prior written notice and opportunity to object by the other Parties; provided that:

- 7.1.1 A Party may assign this Agreement without the consent of the other Parties to any affiliate of the assigning Party with an equal or greater credit rating and with the legal authority and operational ability to satisfy the obligations of the assigning Party under this Agreement, provided that the Interconnection Customer promptly notifies the NYISO and the Connecting Transmission Owner of any such assignment. A Party may assign this Agreement without the consent of the other Parties in connection with the sale, merger, restructuring, or transfer of a substantial portion of all of its assets, including the Interconnection Facilities it owns, so long as the assignee in such a transaction directly assumes all rights, duties and obligation arising under this Agreement.
- 7.1.2 The Interconnection Customer shall have the right to assign this Agreement, without the consent of the NYISO or Connecting Transmission Owner, for collateral security purposes to aid in providing financing for the Small Generating Facility.
- 7.1.3 Any attempted assignment that violates this article is void and ineffective. Assignment shall not relieve a Party of its obligations, nor shall a Party's obligations be enlarged, in whole or in part, by reason thereof. An assignee is responsible for meeting the same financial, credit, and insurance obligations as the Interconnection Customer. Where required, consent to assignment will not be unreasonably withheld, conditioned or delayed.

7.2 Limitation of Liability

Each Party's liability to the other Parties for any loss, cost, claim, injury, liability, or expense, including reasonable attorney's fees, relating to or arising from any act or omission in its performance of this Agreement, shall be limited to the amount of direct damage actually incurred. In no event shall any Party be liable to the other Parties for any indirect, special, consequential, or punitive damages.

7.3 Indemnity

- 7.3.1 This provision protects each Party from liability incurred to third parties as a result of carrying out the provisions of this Agreement. Liability under this provision is exempt from the general limitations on liability found in article 7.2.
- 7.3.2 Each Party (the “Indemnifying Party”) shall at all times indemnify, defend, and hold harmless the other Parties (each an “ Indemnified Party”) from, any and all damages, losses, claims, including claims and actions relating to injury to or death of any person or damage to property, the alleged violation of any Environmental Law, or the release or threatened release of any Hazardous Substance, demand, suits, recoveries, costs and expenses, court costs, attorney fees, and all other obligations by or to third parties (any and all of these a “Loss”), arising out of or resulting from (i) the Indemnified Party’s performance under this Agreement on behalf of the Indemnifying Party, except in cases where the Indemnifying Party can demonstrate that the Loss of the Indemnified Party was caused by the gross negligence or intentional wrongdoing by the Indemnified Party or (ii) the violation by the Indemnifying Party of any Environmental Law or the release by the Indemnifying Party of a Hazardous Substance.
- 7.3.3 If a Party is entitled to indemnification under this article as a result of a claim by a third party, and the Indemnifying Party fails, after notice and reasonable opportunity to proceed under this article, to assume the defense of such claim, such Indemnified Party may at the expense of the Indemnifying Party contest, settle or consent to the entry of any judgment with respect to, or pay in full, such claim.
- 7.3.4 If an Indemnifying Party is obligated to indemnify and hold any Indemnified Party harmless under this article, the amount owing to the Indemnified Party shall be the amount of such Indemnified Party’s actual loss, net of any insurance or other recovery.
- 7.3.5 Promptly after receipt by an Indemnified Party of any claim or notice of the commencement of any action or administrative or legal proceeding or investigation as to which the indemnity provided for in this article may apply, the Indemnified Party shall notify the Indemnifying Party of such fact. Any failure of or delay in such notification shall not affect a Party’s indemnification obligation unless such failure or delay is materially prejudicial to the Indemnifying Party.

7.4 Consequential Damages

Other than as expressly provided for in this Agreement, no Party shall be liable under any provision of this Agreement for any losses, damages, costs or expenses for any special, indirect, incidental, consequential, or punitive damages, including but not limited to loss of profit or revenue, loss of the use of equipment, cost of capital, cost of temporary equipment or services, whether based in whole or in part in contract, in tort, including negligence, strict liability, or any other theory of liability; provided, however, that damages for which a Party may be liable to another Party under another agreement will not be considered to be special, indirect, incidental, or consequential damages hereunder.

7.5 Force Majeure

- 7.5.1 As used in this article, a Force Majeure Event shall mean “any act of God, labor disturbance, act of the public enemy, war, insurrection, riot, fire, storm or flood, explosion, breakage or accident to machinery or equipment, any order, regulation or restriction imposed by governmental, military or lawfully established civilian authorities, or any other cause beyond a Party’s control. A Force Majeure Event does not include an act of negligence or intentional wrongdoing.” For the purposes of this article, this definition of Force Majeure shall supersede the definitions of Force Majeure set out in Section 32.10.1 of the NYISO OATT.
- 7.5.2 If an event of Force Majeure prevents a Party from fulfilling any obligations under this Agreement, the Party affected by the Force Majeure event (Affected Party) shall promptly notify the other Parties, either in writing or via the telephone, of the existence of the Force Majeure event. The notification must specify in reasonable detail the circumstances of the Force Majeure event, its expected duration, and the steps that the Affected Party is taking to mitigate the effects of the event on its performance. The Affected Party shall keep the other Parties informed on a continuing basis of developments relating to the Force Majeure event until the event ends. The Affected Party will be entitled to suspend or modify its performance of obligations under this Agreement (other than the obligation to make payments) only to the extent that the effect of the Force Majeure event cannot be mitigated by the use of Reasonable Efforts. The Affected Party will use Reasonable Efforts to resume its performance as soon as possible.

7.6 Breach and Default

- 7.6.1 No Breach of this Agreement shall exist where such failure to discharge an obligation (other than the payment of money) is the result of a Force Majeure event or the result of an act or omission of the other Parties. Upon a Breach, the non-breaching Party shall give written notice of such Breach to the Breaching Party. Except as provided in article 7.6.2, the Breaching Party shall have 60 calendar days from receipt of the Breach notice within which to cure such Breach; provided however, if such Breach is not capable of cure within 60 calendar days, the Breaching Party shall commence such cure within 20 calendar days after notice and continuously and diligently complete such cure within six months from receipt of the Breach notice; and, if cured within such time, the Breach specified in such notice shall cease to exist.
- 7.6.2 If a Breach is not cured as provided in this article, or if a Breach is not capable of being cured within the period provided for herein, a Default shall exist and the non-defaulting Parties acting together shall thereafter have the right to terminate this Agreement, in accordance with article 3.3 hereof, by written notice to the Defaulting Party at any time until cure occurs, and be relieved of any further obligation hereunder and, whether or not those Parties terminate this Agreement, to recover from the Defaulting Party all amounts due hereunder, plus all other damages and remedies to which they are entitled at law or in equity. The provisions of this article shall survive termination of this Agreement.
- 7.6.3 In cases where the Interconnection Customer has elected to proceed under Section 32.3.5.3 of the SGIP, if the Interconnection Request is withdrawn or deemed withdrawn pursuant to the SGIP during the term of this Agreement, this Agreement shall terminate.

ARTICLE 8

INSURANCE

- 8.1 The Interconnection Customer shall, at its own expense, maintain in force general liability insurance without any exclusion for liabilities related to the interconnection undertaken pursuant to this Agreement. The amount of such insurance shall be sufficient to insure against all reasonably foreseeable direct liabilities given the size and nature of the generating equipment being interconnected, the interconnection itself, and the characteristics of the system to which the interconnection is made. Such insurance coverage is specified in Attachment 7 to this Agreement. The Interconnection Customer shall obtain additional insurance only if necessary as a function of owning and operating a generating facility. Such insurance shall be obtained from an insurance provider authorized to do business in New York State where the interconnection is located. Certification that such insurance is in effect shall be provided upon request of the Connecting Transmission Owner, except that the Interconnection Customer shall show proof of insurance to the Connecting Transmission Owner no later than ten Business Days prior to the anticipated commercial operation date. An Interconnection Customer of sufficient creditworthiness may propose to self-insure for such liabilities, and such a proposal shall not be unreasonably rejected.
- 8.2 The NYISO and Connecting Transmission Owner agree to maintain general liability insurance or self-insurance consistent with the existing commercial practice. Such insurance or self-insurance shall not exclude the liabilities undertaken pursuant to this Agreement.
- 8.3 The Parties further agree to notify one another whenever an accident or incident occurs resulting in any injuries or damages that are included within the scope of coverage of such insurance, whether or not such coverage is sought.

ARTICLE 9

CONFIDENTIALITY

- 9.1 Confidential Information shall mean any confidential and/or proprietary information provided by one Party to the other Party that is clearly marked or otherwise designated "Confidential." For purposes of this Agreement all design, operating specifications, and metering data provided by the Interconnection Customer shall be deemed Confidential Information regardless of whether it is clearly marked or otherwise designated as such. Confidential Information shall include, without limitation, information designated as such by the NYISO Code of Conduct contained in Attachment F to the NYISO OATT.
- 9.2 Confidential Information does not include information previously in the public domain, required to be publicly submitted or divulged by Governmental Authorities (after notice to the other Party and after exhausting any opportunity to oppose such publication or release), or necessary to be divulged in an action to enforce this Agreement. Each Party receiving Confidential Information shall hold such information in confidence and shall not disclose it to any third party nor to the public without the prior written authorization from the Party providing that information, except to fulfill obligations under this Agreement, or to fulfill legal or regulatory requirements.
- 9.2.1 Each Party shall employ at least the same standard of care to protect Confidential Information obtained from the other Parties as it employs to protect its own Confidential Information.
- 9.2.2 Each Party is entitled to equitable relief, by injunction or otherwise, to enforce its rights under this provision to prevent the release of Confidential Information without bond or proof of damages, and may seek other remedies available at law or in equity for breach of this provision.
- 9.3 Notwithstanding anything in this article to the contrary, and pursuant to 18 CFR § 1b.20, if FERC, during the course of an investigation or otherwise, requests information from one of the Parties that is otherwise required to be maintained in confidence pursuant to this Agreement, the Party shall provide the requested information to FERC, within the time provided for in the request for information. In providing the information to FERC, the Party may, consistent with 18 CFR § 388.112, request that the information be treated as confidential and non-public by FERC and that the information be withheld from public disclosure. Each Party is prohibited from notifying the other Parties to this Agreement prior to the release of the Confidential Information to FERC. The Party shall notify the other Parties to this Agreement when it is notified by FERC that a request to release Confidential Information has been received by FERC, at which time either of the Parties may respond before such information would be made public, pursuant to 18 CFR § 388.112. Requests from a state regulatory body conducting a confidential investigation shall be treated in a similar manner if consistent with the applicable state rules and regulations.
- 9.4 Consistent with the provisions of this article 9, the Parties to this Agreement will cooperate in good faith to provide each other, Affected Systems, Affected System Operators, and state and federal regulators the information necessary to carry out the terms of the SGIP and this Agreement.

ARTICLE 10
DISPUTES

- 10.1 The NYISO, Connecting Transmission Owner and Interconnection Customer agree to attempt to resolve all disputes arising out of the interconnection process according to the provisions of this article.
- 10.2 In the event of a dispute, the Parties will first attempt to promptly resolve it on an informal basis. The NYISO will be available to the Interconnection Customer and Connecting Transmission Owner to help resolve any dispute that arises with respect to performance under this Agreement. If the Parties cannot promptly resolve the dispute on an informal basis, then any Party shall provide the other Parties with a written Notice of Dispute. Such Notice shall describe in detail the nature of the dispute.
- 10.3 If the dispute has not been resolved within two Business Days after receipt of the Notice, any Party may contact FERC's Dispute Resolution Service (DRS) for assistance in resolving the dispute.
- 10.4 The DRS will assist the Parties in either resolving their dispute or in selecting an appropriate dispute resolution venue (e.g., mediation, settlement judge, early neutral evaluation, or technical expert) to assist the Parties in resolving their dispute. The result of this dispute resolution process will be binding only if the Parties agree in advance. DRS can be reached at 1-877-337-2237 or via the internet at <http://www.ferc.gov/legal/adr.asp>.
- 10.5 Each Party agrees to conduct all negotiations in good faith and will be responsible for one-third of any costs paid to neutral third-parties.
- 10.6 If any Party elects to seek assistance from the DRS, or if the attempted dispute resolution fails, then any Party may exercise whatever rights and remedies it may have in equity or law consistent with the terms of this Agreement.

ARTICLE 11
TAXES

- 11.1 The Parties agree to follow all applicable tax laws and regulations, consistent with FERC policy and Internal Revenue Service requirements.
- 11.2 Each Party shall cooperate with the other Parties to maintain the other Parties' tax status. Nothing in this Agreement is intended to adversely affect the tax status of any Party including the status of NYISO, or the status of any Connecting Transmission Owner with respect to the issuance of bonds including, but not limited to, Local Furnishing Bonds. Notwithstanding any other provisions of this Agreement, LIPA, NYPA and Consolidated Edison Company of New York, Inc. shall not be required to comply with any provisions of this Agreement that would result in the loss of tax-exempt status of any of their Tax-Exempt Bonds or impair their ability to issue future tax-exempt obligations. For purposes of this provision, Tax-Exempt Bonds shall include the obligations of the Long Island Power Authority, NYPA and Consolidated Edison Company of New York, Inc., the interest on which is not included in gross income under the Internal Revenue Code.
- 11.3 LIPA and NYPA do not waive their exemptions, pursuant to Section 201(f) of the FPA, from Commission jurisdiction with respect to the Commission's exercise of the FPA's general ratemaking authority.
- 11.4 Any payments due to the Connecting Transmission Owner under this Agreement shall be adjusted to include any tax liability incurred by the Connecting Transmission Owner with respect to the interconnection request which is the subject of this Agreement. Such adjustments shall be made in accordance with the provisions of Article 5.17 of the LGIA in Attachment X of the NYISO OATT. Except where otherwise noted, all costs, deposits, financial obligations and the like specified in this Agreement shall be assumed not to reflect the impact of applicable taxes.

ARTICLE 12
MISCELLANEOUS

12.1 Governing Law, Regulatory Authority, and Rules

The validity, interpretation and enforcement of this Agreement and each of its provisions shall be governed by the laws of the state of New York, without regard to its conflicts of law principles. This Agreement is subject to all Applicable Laws and Regulations. Each Party expressly reserves the right to seek changes in, appeal, or otherwise contest any laws, orders, or regulations of a Governmental Authority.

12.2 Amendment

The Parties may amend this Agreement by a written instrument duly executed by the Parties, or under article 12.12 of this Agreement.

12.3 No Third-Party Beneficiaries

This Agreement is not intended to and does not create rights, remedies, or benefits of any character whatsoever in favor of any persons, corporations, associations, or entities other than the Parties, and the obligations herein assumed are solely for the use and benefit of the Parties, their successors in interest and where permitted, their assigns. Notwithstanding the foregoing, any subcontractor of the Connecting Transmission Owner or NYISO assisting either of those Parties with the Interconnection Request covered by this Agreement shall be entitled to the benefits of indemnification provided for under Article 7.3 of this Agreement and the limitation of liability provided for in Article 7.2 of this Agreement.

12.4 Waiver

- 12.4.1 The failure of a Party to this Agreement to insist, on any occasion, upon strict performance of any provision of this Agreement will not be considered a waiver of any obligation, right, or duty of, or imposed upon, such Party.
- 12.4.2 Any waiver at any time by a Party of its rights with respect to this Agreement shall not be deemed a continuing waiver or a waiver with respect to any other failure to comply with any other obligation, right, duty of this Agreement. Termination or default of this Agreement for any reason by Interconnection Customer shall not constitute a waiver of the Interconnection Customer's legal rights to obtain an interconnection from the NYISO. Any waiver of this Agreement shall, if requested, be provided in writing.

12.5 Entire Agreement

This Agreement, including all Attachments, constitutes the entire agreement between the Parties with reference to the subject matter hereof, and supersedes all prior and contemporaneous understandings or agreements, oral or written, between the Parties with respect to the subject matter of this Agreement. There are no other agreements, representations, warranties, or covenants which constitute any part of the consideration for, or any condition to, any Party's compliance with its obligations under this Agreement.

12.6 Multiple Counterparts

This Agreement may be executed in two or more counterparts, each of which is deemed an original but all constitute one and the same instrument.

12.7 No Partnership

This Agreement shall not be interpreted or construed to create an association, joint venture, agency relationship, or partnership between the Parties or to impose any partnership obligation or partnership liability upon any Party. No Party shall have any right, power or authority to enter into any agreement or undertaking for, or act on behalf of, or to act as or be an agent or representative of, or to otherwise bind, another Party.

12.8 Severability

If any provision or portion of this Agreement shall for any reason be held or adjudged to be invalid or illegal or unenforceable by any court of competent jurisdiction or other Governmental Authority, (1) such portion or provision shall be deemed separate and independent, (2) the Parties shall negotiate in good faith to restore insofar as practicable the benefits to each Party that were affected by such ruling, and (3) the remainder of this Agreement shall remain in full force and effect.

12.9 Security Arrangements

Infrastructure security of electric system equipment and operations and control hardware and software is essential to ensure day-to-day reliability and operational security. FERC expects the NYISO, the Connecting Transmission Owner, Market Participants, and Interconnection Customers interconnected to electric systems to comply with the recommendations offered by the President's Critical Infrastructure Protection Board and, eventually, best practice recommendations from the electric reliability authority. All public utilities are expected to meet basic standards for system infrastructure and operational security, including physical, operational, and cyber-security practices.

12.10 Environmental Releases

Each Party shall notify the other Parties, first orally and then in writing, of the release of any hazardous substances, any asbestos or lead abatement activities, or any type of remediation activities related to the Small Generating Facility or the Interconnection Facilities, each of which may reasonably be expected to affect the other Parties. The notifying Party shall (1) provide the notice as soon as practicable, provided such Party makes a good faith effort to provide the notice no later than 24 hours after such Party becomes aware of the occurrence, and (2) promptly furnish to the other Parties copies of any publicly available reports filed with any governmental authorities addressing such events.

12.11 Subcontractors

Nothing in this Agreement shall prevent a Party from utilizing the services of any subcontractor as it deems appropriate to perform its obligations under this Agreement; provided, however, that each Party shall require its subcontractors to comply with all applicable terms and conditions of this Agreement in providing such services and each Party shall remain primarily liable to the other Parties for the performance of such subcontractor.

- 12.11.1 The creation of any subcontract relationship shall not relieve the hiring Party of any of its obligations under this Agreement. The hiring Party shall be fully responsible to the other Parties to the extent provided for in Sections 32.7.2 and 32.7.3 above for the acts or omissions of any subcontractor the hiring Party hires as if no subcontract had been made; provided, however, that in no event shall the NYISO or Connecting Transmission Owner be liable for the actions or inactions of the Interconnection Customer or its subcontractors with respect to obligations of the Interconnection Customer under this Agreement. Any applicable obligation imposed by this Agreement upon the hiring Party shall be equally binding upon, and shall be construed as having application to, any subcontractor of such Party.
- 12.11.2 The obligations under this article will not be limited in any way by any limitation of subcontractor's insurance.

12.12 Reservation of Rights

Nothing in this Agreement shall alter the right of the NYISO or Connecting Transmission Owner to make unilateral filings with FERC to modify this Agreement with respect to any rates, terms and conditions, charges, classifications of service, rule or regulation under Section 205 or any other applicable provision of the Federal Power Act and FERC's rules and regulations thereunder which rights are expressly reserved herein, and the existing rights of the Interconnection Customer to make a unilateral filing with FERC to modify this Agreement under any applicable provision of the Federal Power Act and FERC's rules and regulations are also expressly reserved herein; provided that each Party shall have the right to protest any such filing by another Party and to participate fully in any proceeding before FERC in which such modifications may be considered. Nothing in this Agreement shall limit the rights of the Parties or of FERC under Sections 205 or 206 of the Federal Power Act and FERC's rules and regulations, except to the extent that the Parties otherwise agree as provided herein.

ARTICLE 13
NOTICES

13.1 General

Unless otherwise provided in this Agreement, any written notice, demand, or request required or authorized in connection with this Agreement (“Notice”) shall be deemed properly given if delivered in person, delivered by recognized national carrier service, or sent by first class mail, postage prepaid, to the person specified below:

If to the Interconnection Customer:

Albany Energy LLC
Attention: General Manager
5087 Junction Road
Lockport, NY 14094-9601
Phone: (716) 439-1004
Fax: (716) 439-1000

If to the Connecting Transmission Owner:

Niagara Mohawk Power Corporation d/b/a National Grid
Attention : Director, Transmission Commercial Services
40 Sylvan Road
Waltham, MA 02451-1120
Phone: 781-907-2422
Fax: 315-428-5114

If to the NYISO:

Before commercial operation of the Large Generating Facility:

New York Independent System Operator, Inc.
Attention: Vice President, System and Resource Planning
10 Krey Boulevard
Rensselaer, NY 12144
Phone: (518) 356-6000
Fax: (518) 356-6118

After commercial operation of the Large Generating Facility

New York Independent System Operator, Inc.

Attention: Vice President, Operations

3890 Carman Road

Schenectady, NY 12303

Phone: (518) 356-6000

Fax: (518) 356-6118

13.2 Billing and Payment

Billings and payments shall be sent to the addresses set out below:

Interconnection Customer:

Albany Energy LLC

Attention: Fortistar Accounts Payable

One North Lexington Ave.

White Plains, NY

Phone: (914) 421-4900

Fax: (914) 421-0052

Connecting Transmission Owner:

Niagara Mohawk Power Corporation d/b/a National Grid

Attention : Director, Transmission Commercial Services

40 Sylvan Road

Waltham, MA 02451-1120

Phone: 781-907-2422

Fax: 315-428-5114

13.3 Alternative Forms of Notice

Any notice or request required or permitted to be given by either Party to the other and not required by this Agreement to be given in writing may be so given by telephone, facsimile or e-mail to the telephone numbers and e-mail addresses set out below:

If to the Interconnection Customer:

Albany Energy LLC
Attention: General Manager
5087 Junction Road
Lockport, NY 14094-9601
Phone: (716) 439-1004
Fax: (716) 439-1000

If to the Connecting Transmission Owner:

Niagara Mohawk Power Corporation d/b/a National Grid
Attention : Director, Transmission Commercial Services
40 Sylvan Road
Waltham, MA 02451-1120
Phone: 781-907-2422
Fax: 315-428-5114

If to the NYISO:

Before commercial operation of the Large Generating Facility:

New York Independent System Operator, Inc.
Attention: Vice President, System and Resource Planning
10 Krey Boulevard
Rensselaer, NY 12144
Phone: (518) 356-6000
Fax: (518) 356-6118

After commercial operation of the Large Generating Facility

New York Independent System Operator, Inc.
Attn: Vice President, Operations

3890 Carman Road

Schenectady, NY 12303

Phone: (518) 356-6000

Fax: (518) 356-6118

13.4 Designated Operating Representative

The Parties may also designate operating representatives to conduct the communications which may be necessary or convenient for the administration of this Agreement. This person will also serve as the point of contact with respect to operations and maintenance of the Party's facilities.

Interconnection Customer's Operating Representative:

Albany Energy LLC

Attention: General Manager

5087 Junction Road

Lockport, NY 14094-9601

Phone: (716) 439-1004

Fax: (716) 439-1000

Albany Energy LLC

Attention: Operator

525 Rapp Rd.

Albany, NY 12205-4958

Phone: (518) 862-0004

Fax: (518) 862-0014

Transmission Provider's Operating Representative:

Niagara Mohawk Power Corporation d/b/a National Grid

Attention : Director, Transmission Commercial Services

40 Sylvan Road

Waltham, MA 02451-1120

Phone: 781-907-2422

Fax: 315-428-5114

NYISO's Operating Representative:

Before commercial operation of the Large Generating Facility:

New York Independent System Operator, Inc.
Attention: Vice President, System and Resource Planning
10 Krey Boulevard
Rensselaer, NY 12144
Phone: (518) 356-6000
Fax: (518) 356-6118

After commercial operation of the Large Generating Facility

New York Independent System Operator, Inc.

Attn: Vice President, Operations

3890 Carman Road

Schenectady, NY 12303

Phone: (518) 356-6000
Fax: (518) 356-6118

13.5 Changes to the Notice Information

Either Party may change this information by giving five Business Days written notice prior to the effective date of the change.

ARTICLE 14
SIGNATURES

IN WITNESS WHEREOF, the Parties have caused this Agreement to be executed by their respective duly authorized representatives.

For the New York Independent System Operator, Inc.

/s/ Henry Chao

Henry Chao

Title: Vice President, System and Resource Planning
New York Independent System Operator, Inc.

Date: 10/19/2012

For the Connecting Transmission Owner

/s/ William I. Malee

William I. Malee

Title: Director, Transmission Commercial
Niagara Mohawk Power Corporation d/b/a National Grid

Date: 10/5/2012

For the Interconnection Customer

/s/ David R. Wentworth

David R. Wentworth

Title: Senior Vice President, Albany Energy LLC

Date: 10/16/2012

Glossary of Terms

Affected System – An electric system other than the transmission system owned, controlled or operated by the Connecting Transmission Owner that may be affected by the proposed interconnection.

Affected System Operator – Affected System Operator shall mean the operator of any Affected System.

Affected Transmission Owner -- The New York public utility or authority (or its designated agent) other than the Connecting Transmission Owner that (i) owns facilities used for the transmission of Energy in interstate commerce and provides Transmission Service under the Tariff, and (ii) owns, leases or otherwise possesses an interest in a portion of the New York State Transmission System where System Deliverability Upgrades or System Upgrade Facilities are installed pursuant to Attachment Z and Attachment S to the NYISO OATT.

Applicable Laws and Regulations – All duly promulgated applicable federal, state and local laws, regulations, rules, ordinances, codes, decrees, judgments, directives, or judicial or administrative orders, permits and other duly authorized actions of any Governmental Authority, including but not limited to Environmental Law.

Applicable Reliability Standards – The criteria, requirements and guidelines of the North American Electric Reliability Council, the Northeast Power Coordinating Council, the New York State Reliability Council and related and successor organizations, or the Transmission District to which the Interconnection Customer's Small Generating Facility is directly interconnected, as those criteria, requirements and guidelines are amended and modified and in effect from time to time; provided that no Party shall waive its right to challenge the applicability of or validity of any criterion, requirement or guideline as applied to it in the context of Attachment Z to the NYISO OATT and this Agreement. For the purposes of this Agreement, this definition of Applicable Reliability Standards shall supersede the definition of Applicable Reliability Standards set out in Attachment X to the NYISO OATT.

Base Case -- The base case power flow, short circuit, and stability data bases used for the Interconnection Studies by NYISO, Connecting Transmission Owner or Interconnection Customer; described in Section 32.2.3 of the Large Facility Interconnection Procedures.

Breach - The failure of a Party to perform or observe any material term or condition of this Agreement.

Business Day – Monday through Friday, excluding federal holidays.

Capacity Resource Interconnection Service -- The service provided by NYISO to interconnect the Interconnection Customer's Small Generating Facility to the New York State Transmission System or Distribution System in accordance with the NYISO Deliverability Interconnection Standard, to enable the New York State Transmission System to deliver electric capacity from the Small Generating Facility, pursuant to the terms of the NYISO OATT.

Connecting Transmission Owner – The New York public utility or authority (or its designated agent) that (i) owns facilities used for the transmission of Energy in interstate commerce and provides Transmission Service under the Tariff, (ii) owns, leases or otherwise possesses an interest in the portion

of the New York State Transmission System or Distribution System at the Point of Interconnection, and (iii) is a Party to the Standard Small Generator Interconnection Agreement.

Deliverability Interconnection Standard – The standard that must be met by any Small Generating Facility larger than 2MW proposing to interconnect to the New York State Transmission System or Distribution System and to become a qualified Installed Capacity Supplier, and must be met by any merchant transmission project proposing to interconnect to the New York State Transmission System and receive Unforced Capacity Delivery Rights. To meet the NYISO Deliverability Interconnection Standard, the Interconnection Customer must, in accordance with the rules in Attachment S to the NYISO OATT, fund or commit to fund the System Deliverability Upgrades identified for its project in the Class Year Deliverability Study.

Default – The failure of a Party in Breach of this Agreement to cure such Breach under the Small Generator Interconnection Agreement.

Distribution System – The Transmission Provider’s facilities and equipment used to distribute electricity that are not under the operational control of the NYISO, and are subject to the SGIP under FERC Order No. 2006. For the purpose of this Agreement, the term Distribution System shall not include LIPA’s distribution facilities.

Distribution Upgrades – The additions, modifications, and upgrades to the Connecting Transmission Owner’s Distribution System at or beyond the Point of Interconnection to facilitate interconnection of the Small Generating Facility and render the transmission service necessary to effect the Interconnection Customer’s wholesale sale of electricity in interstate commerce. Distribution Upgrades do not include Interconnection Facilities or System Upgrade Facilities or System Deliverability Upgrades.

Energy Resource Interconnection Service – The service provided by NYISO to interconnect the Interconnection Customer’s Small Generating Facility to the New York State Transmission System or Distribution System in accordance with the NYISO Minimum Interconnection Standard, to enable the New York State Transmission System to receive Energy and Ancillary Services from the Small Generating Facility, pursuant to the terms of the NYISO OATT.

Force Majeure – Any act of God, labor disturbance, act of the public enemy, war, insurrection, riot, fire, storm or flood, explosion, breakage or accident to machinery or equipment, any order, regulation or restriction imposed by governmental, military or lawfully established civilian authorities, or any other cause beyond a Party’s control. A Force Majeure event does not include an act of negligence or intentional wrongdoing. For the purposes of this Agreement, this definition of Force Majeure shall supersede the definitions of Force Majeure set out in Section 2.11 of the NYISO Open Access Transmission Tariff.

Good Utility Practice – Any of the practices, methods and acts engaged in or approved by a significant portion of the electric industry during the relevant time period, or any of the practices, methods and acts which, in the exercise of reasonable judgment in light of the facts known at the time the decision was made, could have been expected to accomplish the desired result at a reasonable cost consistent with good business practices, reliability, safety and expedition. Good Utility Practice is not intended to be limited to

the optimum practice, method, or act to the exclusion of all others, but rather to be acceptable practices, methods, or acts generally accepted in the region.

Governmental Authority – Any federal, state, local or other governmental regulatory or administrative agency, court, commission, department, board, or other governmental subdivision, legislature, rulemaking board, tribunal, or other governmental authority having jurisdiction over the Parties, their respective facilities, or the respective services they provide, and exercising or entitled to exercise any administrative, executive, police, or taxing authority or power; provided, however, that such term does not include the Interconnection Customer, NYISO, Affected Transmission Owner, Connecting Transmission Owner or any Affiliate thereof.

Interconnection Customer – Any entity, including the Transmission Owner or any of the affiliates or subsidiaries, that proposes to interconnect its Small Generating Facility with the New York State Transmission System or the Distribution System.

Interconnection Facilities – The Transmission Provider’s Interconnection Facilities and the Interconnection Customer’s Interconnection Facilities. Collectively, Interconnection Facilities include all facilities and equipment between the Small Generating Facility and the Point of Interconnection, including any modification, additions or upgrades that are necessary to physically and electrically interconnect the Small Generating Facility to the New York State Transmission System or the Distribution System. Interconnection Facilities are sole use facilities and shall not include Distribution Upgrades or System Upgrade Facilities.

Interconnection Request – The Interconnection Customer’s request, in accordance with the Tariff, to interconnect a new Small Generating Facility, or to increase the capacity of, or make a material modification to the operating characteristics of, an existing Small Generating Facility that is interconnected with the New York State Transmission System or the Distribution System. For the purposes of this Agreement, this definition of Interconnection Request shall supersede the definition of Interconnection Request set out in Attachment X to the NYISO OATT.

Interconnection Study – Any study required to be performed under Sections 32.2 or 32.3 of the SGIP.

Material Modification – A modification that has a material impact on the cost or timing of any Interconnection Request with a later queue priority date.

Minimum Interconnection Standard – The reliability standard that must be met by any Small Generating Facility proposing to connect to the New York State Transmission System or Distribution System. The Standard is designed to ensure reliable access by the proposed project to the New York State Transmission System. The Standard does not impose any deliverability test or deliverability requirement on the proposed interconnection.

New York State Transmission System – **New York State Transmission System** shall mean the entire New York State electric transmission system, which includes (i) the Transmission Facilities under ISO Operational Control; (ii) the Transmission Facilities Requiring ISO Notification; and (iii) all remaining transmission facilities within the New York Control Area.

Operating Requirements – Any operating and technical requirements that may be applicable due to Regional Transmission Organization, Independent System Operator, control area, or the Connecting Transmission Owner’s requirements, including those set forth in the Small Generator Interconnection Agreement. Operating Requirements shall include Applicable Reliability Standards.

Party or Parties – The NYISO, Connecting Transmission Owner, Interconnection Customer or any combination of the above.

Point of Interconnection – The point where the Interconnection Facilities connect with the New York State Transmission System or the Distribution System.

Reasonable Efforts – With respect to an action required to be attempted or taken by a Party under this Agreement, efforts that are timely and consistent with Good Utility Practice and are otherwise substantially equivalent to those a Party would use to protect its own interests.

Small Generating Facility – The Interconnection Customer’s device no larger than 20 MW for the production of electricity identified in the Interconnection Request, but shall not include the Interconnection Customer’s Interconnection Facilities.

System Deliverability Upgrades – The least costly configuration of commercially available components of electrical equipment that can be used, consistent with Good Utility Practice and Applicable Reliability Requirements, to make the modifications or additions to the existing New York State Transmission System that are required for the proposed project to connect reliably to the system in a manner that meets the NYISO Deliverability Interconnection Standard for Capacity Resource Interconnection Service.

System Upgrade Facilities – The least costly configuration of commercially available components of electrical equipment that can be used, consistent with good utility practice and Applicable Reliability Requirements to make the modifications to the existing transmission system that are required to maintain system reliability due to: (i) changes in the system, including such changes as load growth and changes in load pattern, to be addressed in the form of generic generation or transmission projects; and (ii) proposed interconnections. In the additions to the existing New York State Transmission System that are required for the proposed project to connect reliably to the system in a manner that meets the NYISO Minimum Interconnection Standard.

Tariff – The NYISO’s Open Access Transmission Tariff, as filed with the FERC, and as amended or supplemented from time to time, or any successor tariff.

Upgrades – The required additions and modifications to the Connecting Transmission Owner’s portion of the New York State Transmission System or the Distribution System at or beyond the Point of Interconnection. Upgrades may be System Upgrade Facilities or System Deliverability Upgrades Distribution Upgrades. Upgrades do not include Interconnection Facilities.

Detailed Scope of Work, Including Description and Costs of the Small Generating Facility, Interconnection Facilities, and Metering Equipment

Equipment, including the Small Generating Facility, Interconnection Facilities, and metering equipment shall be itemized and identified as being owned by the Interconnection Customer, or the Connecting Transmission Owner. The NYISO, in consultation with the Connecting Transmission Owner, will provide a best estimate itemized cost, including overheads, of its Interconnection Facilities and metering equipment, and a best estimate itemized cost of the annual operation and maintenance expenses associated with its Interconnection Facilities and metering equipment.

I. Project Description

A. Description of Existing Facility

The Interconnection Customer has constructed a 2.8 MW landfill gas generation facility located at 525 Rapp Road, Albany New York (“Existing Facility”). The Existing Facility interconnects to the Connecting Transmission Owner’s 34.5 kV Karner-Patroon Line #5 (“Karner-Patroon Line #5”) via a single breaker tap arrangement.

The Existing Facility consists of:

- Two (2) Caterpillar Model 3516 Engine Generator Sets, 0.925 MW, 1.15 MVA, each with a power factor range of 0.80 lagging to 0.90 leading, giving a total reactive capability for both units of +1.39 MVAR to -0.896 MVAR at the generator terminals;
- One (1) Caterpillar Model 3516 Engine Generator Set, 0.95 MW, 1.18 MVA, with a power factor range of 0.80 lagging to 0.90 leading, giving a gross a reactive capability for the unit of +.713 MVAR to -.460 MVAR at the generator terminals;
- One (1) three-phase 4160 V (Delta) - 480 /277 V (Wye), 300 kVA transformer, 60 kV BIL, 6.5% impedance;
- One (1) ancillary circuit load breaker: 4.16 kV, 1200 A, 40 kAIC, 60 kV BIL;
- Three (3) generator circuit breakers: 4.16 kV, 1200 A, 40 kAIC, 60 kV BIL;
- One (1) 4.16 kV bus that will accommodate connection and protection controls; and
- Utility interconnection protection equipment and relaying controls.

The Point of Change of Ownership (“PCO”) for the Existing Facility is on the existing riser pole (Pole 209-2) at the 34.5 kV insulators on the line side of the Interconnection Customer’s Switch 588.

The Point of Interconnection (“POI”) for the Existing Facility is the tap point (Connecting Transmission Owner’s Pole 17 ½) on the Connecting Transmission Owner’s 34.5 kV Karner-Patroon Line #5 (“Line #5), via the existing 1 mile 34.5 kV Generator Lead Line.

B. Description of New Facility

The Interconnection Customer is expanding the Existing Facility to increase its maximum output capability by 6.4 MW, for a total nameplate capacity of 9.2 MW (“New Facility”). The New Facility will consist of the following equipment:

Four (4) Caterpillar Model 3520 Engine Generator Sets, 1.6 MW, 2 MVA, with a power factor range of 0.80 lagging to 0.90 leading, giving a total reactive capability for all four units of +4.8 MVAR to -3.10 MVAR at the generator terminals;

- One (1) three-phase 4160 (Delta)-480 /277 V (Wye), 500 kVA transformer, 60 kV BIL, 6.5% impedance;
- One (1) main circuit breaker 4.16 kV, 1200 A, 40 kAIC, 60 kV BIL;
- One (1) (ancillary circuit load breaker) 4.16 kV, 1200 A, 40 kAIC, 60 kV BIL;
- Four (4) generator circuit breakers 4.16 kV, 1200 A, 40 kAIC, 60 kV BIL;
- Two (2) 4.16 kV buses that will accommodate connection and protection controls;
- Utility interconnection protection equipment and relaying controls; and
- Two (2) (main feeder switches) 7.2 kV, 1200 A load break switches, 61 kAIC, 60 kV BIL.

The interconnection of the new facilities will be completed in four (4) phases. The Interconnection Customer will initially install and energize two of the four new generators (3.2 MW); the remaining 3.2 MW will be installed and energized by the end of 2015. Specifically each of the four phases will encompass the following:

- Phase 1: Interconnection of two (2) of the four (4) 1.6 MW units;
- Phase 2: Generator Lead Line relocation modifications (see Section II.B below);
- Phase 3: Interconnection of the third 1.6 MW unit; and
- Phase 4: Interconnection of the fourth 1.6 MW unit.

The equipment required for the interconnection of the New Facility will be installed as detailed below. Additionally, the modifications to the Interconnection Facilities resulting from the relocation of the Generator Lead Line are also described below.

The new facility will remain interconnected to the electric system at the existing POI.

II. Interconnection Facilities

A. Interconnection Customer Interconnection Facilities (ICIFs)

As depicted in Attachment 3, Figure 1, the ICIFs will be located on property owned or leased by the Interconnection Customer, and, will consist of two (2) 4.16 kV feeder circuits (1 for the existing plant (“Plant 1”)(generators 1-3) and 1 for the new plant (“Plant 2”)(generators 4-7) that will bring the power from both facilities to new 4.16 kV switchgear, from which the power will be stepped up through a new Plant Step Up (“PSU”) Transformer Station, and interconnect to the electric system via the 34.5 kV switchgear.

The ICIFs shall be designed constructed, operated, and maintained in accordance with the Connecting Transmission Owner’s Electric Service Bulletin 750 Series (“ESB 750s”) and Good Utility Practice.

1. Existing

The ICIFs for the Existing Facility are as follows:

- One (1) three-phase 34.5 kV (wye-grounded) – 4160 V (Delta), 2.5 MVA transformer, 7.5% impedance;
- Three (3) 38 kV, current transformers (“CTs”) (for 38 kV side of the transformer);
- One (1) 38 kV, 34.5kV nominal circuit breaker: 1200 A, 150 kV BIL, 40 kAIC;
- Six (6) 38 kV, distribution class surge arresters;
- 2200 ft. of underground, 3 phase, 34.5 kV line (1/0 MV105 Cu) and associated conduit from the 34.5kV switchgear to the PCO (“Generator Feeder Line”);
- Three (3) single phase pole mounted SMD-IA 200E fuses;
- One (1) 3 pole gang operated load break switch, 34.5 kV, 1200 A, located on the Pole 209-2 (Switch 588);
- One (1) 56k data circuit;
- One (1) cell phone circuit for metering; and
- Positron equipment.

2. New

The ICIFs for the New Facility are as follows:

- The existing 2 MVA transformer shall be replaced with a 34.5 (delta) -4.16 (wye) kV, resistance grounded (3ph, 2.4kV, 24 Ohm, 100A, 10 sec), 10/12MVA transformer with an X/R ratio of 15 and an impedance of 6.5% @ 10MVA;
- Three (3) single phase 38 kV distribution class surge arresters; and
- Three (3) single phase 6 kV distribution class surge arresters.

Per Section II.B below, the Connecting Transmission Owner's Generator Lead Line is being relocated to accommodate the expansion of the landfill. Due to the line relocation, the configuration of the Interconnection Customer's Interconnection Facilities at the PCO will be modified. (See Attachment 3, Figure 2). Specifically, 30 ft of the Generator Feeder Line (between Pole 209-1 and 209-2) will be removed, a new Pole 209 will be set and the following will be relocated to the new Pole 209: three (3) pole gang-operated load break switch (Switch 588), three (3) 38 kV surge arresters, and three (3) single phase pole mounted SMD-IA 200E fuses. In addition, the Generator Feeder Line will terminate on the load side of the insulators at the new Pole 209, as further described in Section II.B below.

B. Connecting Transmission Owner Interconnection Facilities (CTO IFs)

1. Existing

The CTO IFs for the Existing Facility are as follows:

- Line tap at pole 17 ½;
- Approximately 1 mile of overhead 34.5 kV, 336.4 AL, 19 strand cable ("Generator Lead Line");
- One (1) 3 pole gang operated load break switch, 34.5 kV, 1200 A (switch 566) at Pole 209-1;
- Three (3) single phase 29 kV MCOV surge arrestors;
- Three (3) metering potential transformers (PTs) 20125/115;
- Three (3) metering current transformers (CTs) 25:5;
- One (1) revenue meter; and
- One (1) Remote Transmitting Unit (RTU).

2. New

The three (3) existing metering CTs are undersized and shall be replaced with new metering 75:5 CTs.

The Connecting Transmission Owner shall supply and the Interconnection Customer shall install the revenue CTs and complete the primary wiring. The Connecting Transmission Owner shall complete all secondary wiring, testing and commissioning of the CTs.

The Generator Lead Line is being relocated to accommodate the expansion of the landfill (Phase 2). As a result of the line relocation, the configuration of the Generator Lead Line will change as depicted in Attachment 3, Figure 2.

Specifically, the existing Switch 566 and surge arrestors will be removed along with existing poles 209-1 and 209-2, and the following new CTO IFs shall be installed:

- Pole 200, wood pole structure, to be located approximately ½ span from pole 17 ½; and
- 34.5 kV gang operated, load break switch, 600 kV, 200 BIL, to be located on the new Pole 200 (Switch 566).

C. **Estimate of Connecting Transmission Owner Interconnection Facilities**

1. Phase 1

ALBANY LFGTE EXPANSION INTERCONNECTION FACILITIES (PHASE 1)	
Description:	Estimated Costs:
<p>Interconnection Customer Interconnection Facilities (ICIFs):</p> <p>Engineering review and acceptance of ICIFs, including, but not limited to: ICIF drawings and equipment specs, ground grid system, system protection and coordination study, and relay settings.</p>	\$69,000
<p>CTO IFs:</p> <p>Engineering, design, construction, testing and energization of revenue metering equipment.</p>	\$38,000
TOTAL	\$107,000

2. Phase 2

Albany LFGTE Facility: Phase 2 Line Relocation	
Description:	Estimated Costs:
CTO IFs: Engineering, design, construction & testing for relocation of Generator Lead Line	\$54,900
TOTAL	\$54,900

D. O&M Expenses for Interconnection Facilities

In accordance with Article 10.5 of this Agreement, Developer shall be responsible for all reasonable expenses (“O&M Expenses”) associated with the operation, maintenance, repair and replacement of Connecting Transmission Owner’s Attachment Facilities, as such facilities are detailed in Appendix A.

Developer shall have the option to pay such O&M Expenses either under the procedure described in Option 1 or in Option 2 below.

Option 1: Fixed On-Going Charge Payment

Connecting Transmission Owner will invoice and Developer shall pay an annual payment to the Connecting Transmission Owner equal to the product of the Gross Plant Investment associated with the Connecting Transmission Owner Attachment Facility and the Annual Transmission Ongoing Charge Factor, for the term of this Agreement.

All payments due to be made by Developer shall be made within thirty (30) days after receiving an invoice from Connecting Transmission Owner.

The Project’s Gross Connecting Transmission Owner’s Attachment Facilities Plant Investment cost shall be established in writing by Connecting Transmission Owner no later than 90 days following commercial operation.

The Annual On-Going Charge Factor shall be calculated annually each July based on the Connecting Transmission Owner’s most recently filed FERC Form 1 data and will equal the sum of the Revenue Requirement Components as identified on O&M Attachment 1 divided by the Total Gross Plant of the Connecting Transmission Owner. Total Gross Plant shall equal the sum of Item Nos. A (1)(a)(b) and (c) in O&M Attachment 1.

Option 2: Annual Actual O&M Expenses

Developer shall pay for all actual O&M Expenses incurred by Connecting Transmission Owner, which expenses shall be billed by Connecting Transmission Owner quarterly as accumulated during the calendar quarter for which they were incurred.

All payments due to be made by Developer shall be made within thirty (30) days after receiving an invoice from Connecting Transmission Owner, which invoice shall be issued after the end of each calendar quarter for the most recent quarter.

Selection by Developer

Developer shall select which option for paying O&M Expenses by providing written notice to the Connecting Transmission Owner within thirty (30) days after receiving from the Connecting Transmission Owner the Gross Connecting Transmission Owner's Attachment Facilities Plant Investment cost and the most recent Annual Transmission Ongoing Charge Factor. If Developer fails to provide timely notice to Connecting Transmission Owner of the option selected, Developer will be deemed to have selected Option 2: Annual Actual O&M Expenses.

FIGURE 1: PHASE 1

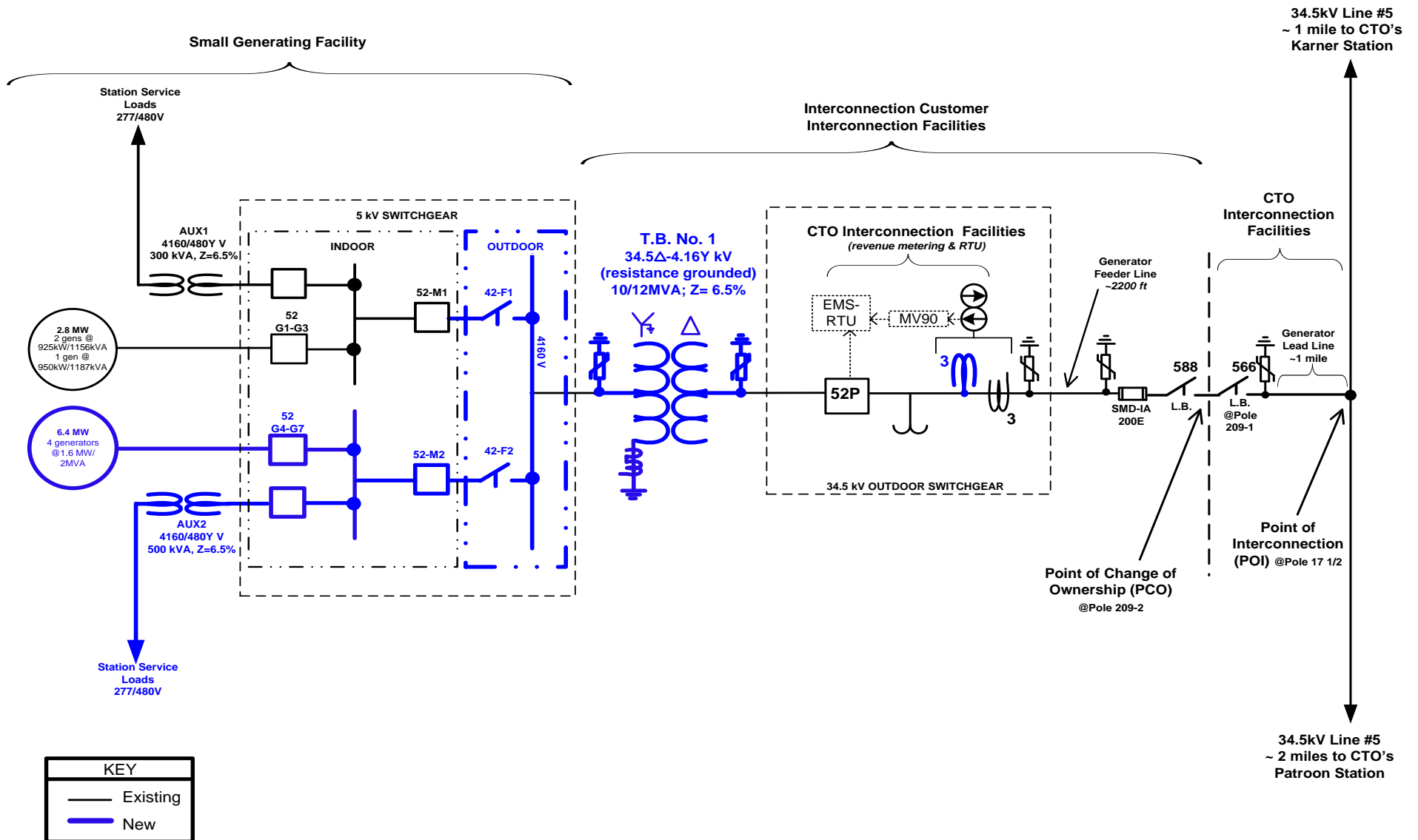
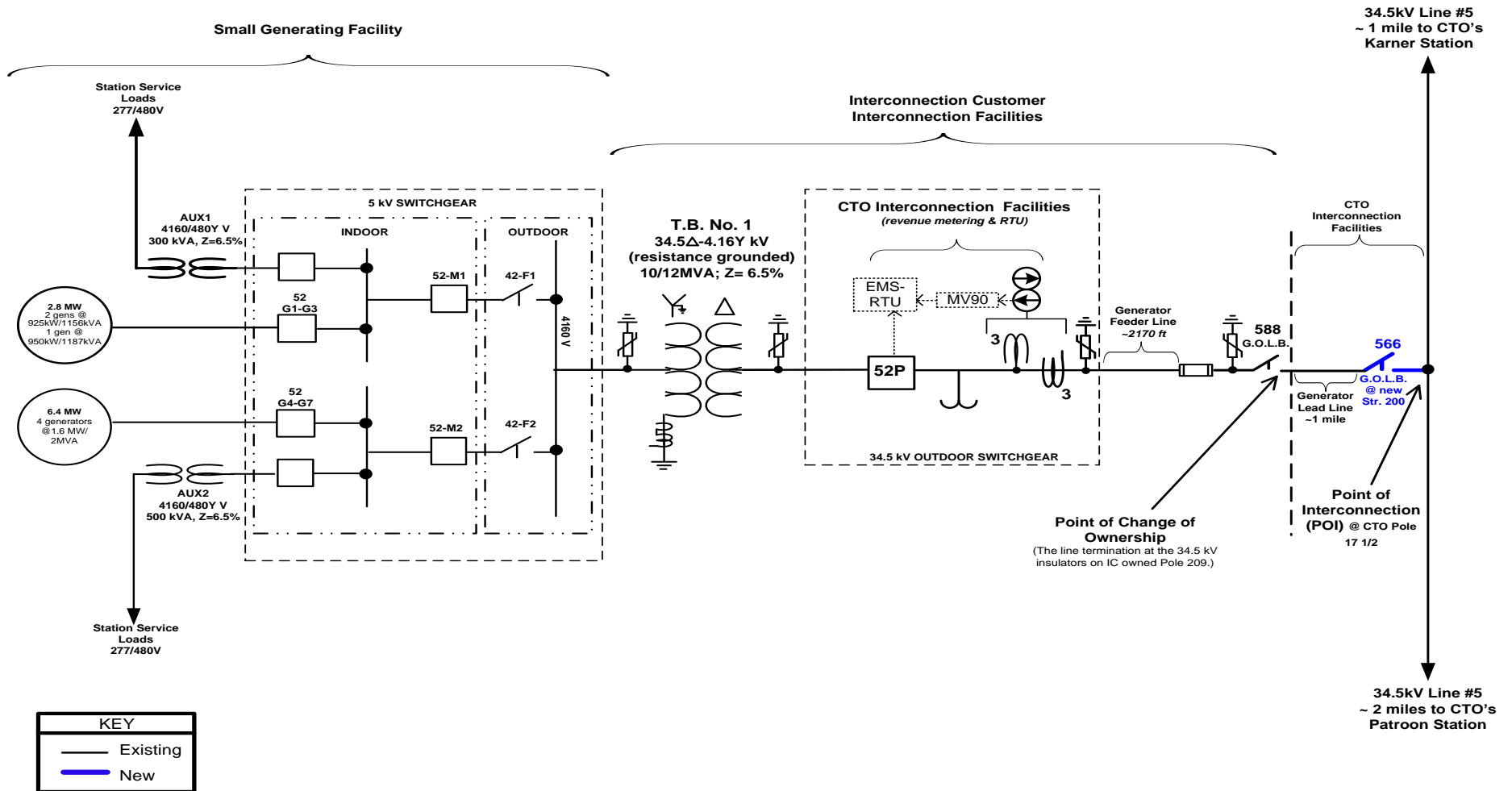

FIGURE 2: PHASE 2

Albany Landfill LFGTE Facility
Phase 2: Generator Lead Line Relocation



Milestones

Task	Milestone	Date	Responsible
1	Execute Cost Reimbursement Agreement	Completed	Interconnection Customer/ Connecting Transmission Owner
2	Issue written authorization to proceed with engineering, design and procurement	Completed	Interconnection Customer
3	Provide security pursuant to Section 11.5 of the Interconnection Agreement	Completed	Interconnection Customer
4	Start Engineering & Procurement (Phase 1)	Completed	Interconnection Customer/ Connecting Transmission Owner
5	Issue Preliminary Design pkg for ICIFs (Phase 1)	Completed	Interconnection Customer
6	Complete Engineering & Procurement (Phase 1)	Completed	Interconnection Customer/ Connecting Transmission Owner
7	Start Construction of generation facilities and ICIFs	Completed	Interconnection Customer
8	Start Construction of CTO IFs and SUFs (Phase 1)	Completed	Connecting Transmission Owner
9	Complete Construction of generation facilities and ICIFs	Completed	Interconnection Customer
10	Complete Construction of CTO IFs and SUFs (Phase 1)	Completed	Connecting Transmission Owner
11	Field verification (Phase 1)	Completed	Connecting Transmission Owner
12	Testing and Commissioning (Phase 1)	Completed	Interconnection Customer/ Connecting Transmission Owner
13	Execute Interconnection Agreement	Completed	ALL
14	Initial Synchronization	Completed	Interconnection Customer/ Connecting Transmission Owner
15	Commercial Operation	Completed	Interconnection Customer
16	Phase 2 Construction Start	Completed	Interconnection Customer/

Task	Milestone	Date	Responsible
			Connecting Transmission Owner
17	Phase 2 Construction Complete	Completed	Interconnection Customer/ Connecting Transmission Owner
18	As Builts and Project Closeout	12/2012	Interconnection Customer/ Connecting Transmission Owner

Agreed to by:

For the NYISO /s/ Henry Chao Date 10/19/12

For the Connecting Transmission Owner /s/ William I. Malee Date 10/15/12

For the Interconnection Customer /s/ David R. Wentworth Date 10/16/12

**Additional Operating Requirements for the New York State Transmission System, the
Distribution System and Affected Systems Needed to Support the Interconnection
Customer's Needs**

The NYISO, in consultation with the Connecting Transmission Owner, shall also provide requirements that must be met by the Interconnection Customer prior to initiating parallel operation with the New York State Transmission System or the Distribution System.

The Interconnection Customer must comply with all applicable NYISO tariffs and procedures, as amended from time to time.

The Interconnection Customer must also comply with the Connecting Transmission Owner's operating instructions and requirements as referenced in Sections 1.5 and 1.6 of this SGIA, which requirements shall include equipment outages and control arrangements, tagging agreements and procedures, maintenance arrangements and responsibilities, company contacts and phone numbers and supervisory equipment.

The Interconnection Customer must comply with relevant provisions of the Connecting Transmission Owner's Electric System Bulletins 756, 750-2010, and 755-2003, including appendices, as amended from time to time, to the extent not inconsistent with the terms of this Agreement or the NYISO OATT.

With respect to Capacity Resource Interconnection Service ("CRIS"), the Small Generating Facility has a CRIS value as of the Effective Date of 2.5 MW. The Interconnection Customer did not elect to have the additional capacity created by the uprate evaluated for deliverability in the Class Year Facilities Study process. Therefore, the Small Generating Facility's CRIS value will be limited to 2.5 MW unless and/or until the Small Generating Facility's CRIS value is modified pursuant to applicable provisions of the NYISO's OATT, including Section 32.4.10.1 of Attachment Z.

Connecting Transmission Owner's Description of its Upgrades and Best Estimate of Upgrade Costs

The NYISO, in consultation with the Connecting Transmission Owner, shall describe Upgrades and provide an itemized best estimate of the cost, including overheads, of the Upgrades and annual operation and maintenance expenses associated with such Upgrades. The Connecting Transmission Owner shall functionalize Upgrade costs and annual expenses as either transmission or distribution related.

The cost estimate for System Upgrade Facilities and System Deliverability Upgrades shall be taken from the NYISO OATT Attachment S cost allocation process or applicable Interconnection Study, as required by Section 32.3.5.3.2 of Attachment Z. The cost estimate for Distribution Upgrades shall include the costs of Distribution Upgrades that are reasonably allocable to the Interconnection Customer at the time the estimate is made, and the costs of any Distribution Upgrades not yet constructed that were assumed in the Interconnection Studies for the Interconnection Customer but are, at the time of the estimate, an obligation of an entity other than the Interconnection Customer.

The cost estimates for Distribution Upgrades and System Upgrade Facilities and System Deliverability Upgrades are estimates. The Interconnection Customer is ultimately responsible for the actual cost of the Distribution Upgrades and System Upgrade Facilities and System Deliverability Upgrades needed for its Small Generating Facility, as that is determined under Attachments S and X and Z of the NYISO OATT.

A. DISTRIBUTION UPGRADES

No Distribution Upgrades are required for the Small Generating Facility expansion.

B. SYSTEM UPGRADE FACILITIES

The increase of generation added to the National Grid sub-transmission line will require relay settings modifications at the remote ends of the 34.5 kV Karner-Patroon Line #5 to which the interconnection is made. The changes, for both the Karner and Patroon Substations shall include, but not be limited to, development, implementation, and testing of new settings for the existing relays.

C. ESTIMATE OF SYSTEM UPGRADE FACILITIES

ALBANY LFGTE EXPANSION SYSTEM UPGRADE FACILITIES	
Description:	Estimated Costs:
SUFs:	
Engineering, design, construction, testing and energization.	
Remote Stations:	
Station #1 Karner Relay settings modifications.	\$4,000
Station #2 Patroon Relay settings modifications	\$4,000
SUF Subtotal	\$8,000

Insurance Coverage

Interconnection Customer shall, at its own expense, maintain in force throughout the period of this Agreement, the following minimum insurance coverage, with insurers authorized to do business in the State of New York:

Commercial General Liability Insurance including, but not limited to, bodily injury, property damage, products/completed operations, contractual and personal injury liability with a combined single limit of \$1 million per occurrence, \$2 million annual aggregate.