

## Attachment B

**INTERCONNECTION AGREEMENT**

**BETWEEN**

**NIAGARA MOHAWK POWER CORPORATION D/B/A NATIONAL GRID**

**AND**

**GR Catalyst Two LLC**

## TABLE OF CONTENTS

<b>Article 1.</b>	<b>Scope and Limitations of Agreement .....</b>	<b>2</b>
1.1.	Applicability .....	2
1.2.	Purpose.....	2
1.3.	Scope of Interconnection Service .....	2
1.4.	Limitations.....	2
1.5.	Responsibilities of the Parties.....	3
1.6.	Parallel Operation Obligations.....	4
1.7.	Metering.....	4
1.8.	Reactive Power <del>and Primary Frequency Response</del> .....	5
1.9.	Capitalized Terms.....	8
<b>Article 2.</b>	<b>Inspection, Testing, Authorization, and Right of Access.....</b>	<b>9</b>
2.1.	Equipment Testing and Inspection.....	9
2.2.	Authorization Required Prior to Parallel Operation .....	9
2.3.	Right of Access.....	10
<b>Article 3.</b>	<b>Effective Date, Term, Termination, and Disconnection .....</b>	<b>11</b>
3.1.	Effective Date .....	11
3.2.	Term of Agreement.....	11
3.3.	Termination.....	11
3.4.	Temporary Disconnection.....	12
<b>Article 4.</b>	<b>Cost Responsibility for Interconnection Facilities and Distribution Upgrades .....</b>	<b>15</b>
4.1.	Interconnection Facilities.....	15
4.2.	Distribution Upgrades.....	15
<b>Article 5.</b>	<b>Cost Responsibility for System Upgrade Facilities and System Deliverability Upgrades .....</b>	<b>16</b>
5.1.	Applicability .....	16
5.2.	System Upgrades .....	16
5.3.	Special Provisions for Affected Systems .....	16
<b>Article 6.</b>	<b>Billing, Payment, Milestones, and Financial Security .....</b>	<b>17</b>
6.1.	Billing and Payment Procedures and Final Accounting .....	17
6.2.	Milestones.....	17
6.3.	Financial Security Arrangements.....	18
<b>Article 7.</b>	<b>Assignment, Liability, Indemnity, Force Majeure, Consequential Damages, and Default .....</b>	<b>19</b>
7.1.	Assignment .....	19
7.2.	Limitation of Liability .....	19
7.3.	Indemnity.....	19
7.4.	Consequential Damages.....	20
7.5.	Force Majeure .....	20
7.6.	Breach and Default .....	21
<b>Article 8.</b>	<b>Insurance .....</b>	<b>23</b>
<b>Article 9.</b>	<b>Confidentiality.....</b>	<b>24</b>
<b>Article 10.</b>	<b>Disputes.....</b>	<b>26</b>

<b>Article 11.</b>	<b>Taxes .....</b>	<b>27</b>
<b>Article 12.</b>	<b>Miscellaneous .....</b>	<b>28</b>
12.1.	Governing Law, Regulatory Authority, and Rules .....	28
12.2.	Amendment.....	28
12.3.	No Third-Party Beneficiaries.....	28
12.4.	Waiver.....	28
12.5.	Entire Agreement.....	28
12.6.	Multiple Counterparts .....	29
12.7.	No Partnership .....	29
12.8.	Severability .....	29
12.9.	Security Arrangements .....	29
12.10.	Environmental Releases.....	29
12.11.	Subcontractors .....	29
12.12.	Reservation of Rights.....	30
<b>Article 13.</b>	<b>Notices.....</b>	<b>31</b>
13.1.	General.....	31
13.2.	Billing and Payment.....	31
13.3.	Alternative Forms of Notice .....	32
13.4.	Designated Operating Representative.....	32
13.5.	Changes to the Notice Information .....	33
<b>Article 14.</b>	<b>Signatures .....</b>	<b>34</b>
Attachment 1 – Glossary of Terms		
Attachment 2 – Detailed Scope of Work, Including Description and Costs of the Small Generating Facility, Interconnection Facilities, and Metering Equipment		
Attachment 3 – One-line Diagram Depicting the Small Generating Facility, Interconnection Facilities, Metering Equipment, and Upgrades		
Attachment 4 – Milestones		
Attachment 5 – Additional Operating Requirements for the New York State Transmission System, the Distribution System and Affected Systems Needed to Support the Interconnection Customer’s Needs		
Attachment 6 – Connecting Transmission Owner’s Description of its Upgrades and Best Estimate of Upgrade Costs		
Attachment 7 – Insurance Coverage		
Attachment 8 – ESB 751 Submittal Requirements		
Attachment 9 – Relay Settings and Adjustments		
Attachment 10 – Form of Letter to NYISO		
Attachment 11 – RTU Standards and Specifications		

This Interconnection Agreement (“Agreement”) is made and entered into this 26th day of November, 2019, by and between Niagara Mohawk Power Corporation d/b/a National Grid, a corporation existing under the laws of the State of New York (“Connecting Transmission Owner”), and GR Catalyst Two LLC, a limited liability company organized and existing under the laws of the State of New York (“Interconnection Customer”) each hereinafter sometimes referred to individually as “Party” or referred to together as the “Parties.”

Connecting Transmission Owner Information

Niagara Mohawk Power Corporation d/b/a National Grid  
Attention: Kathryn Cox-Arslan, Director, Transmission Commercial

Address: 40 Sylvan Road  
City: Waltham State: MA Zip: 02451  
Phone: (781) 907-2422  
Fax: (781) 907-5707

Interconnection Customer Information

GR Catalyst Two LLC  
Attention: General Counsel  
Address: 1401 Walnut Street, Suite 420  
City: Boulder State: Colorado Zip: 80302  
Phone: 303-615-3104  
Fax: 720-420-9956

Interconnection Customer Application No: N/A.

In consideration of the mutual covenants set forth herein, the Parties agree as follows:

## **Article 1. Scope and Limitations of Agreement**

### **1.1. Applicability**

This Small Generator Interconnection Agreement (“SGIA”) shall be used for all Interconnection Requests submitted under the Small Generator Interconnection Procedures (SGIP) except for those submitted under the 10 kW Inverter Process contained in SGIP Attachment 5.

### **1.2. Purpose**

This Agreement governs the terms and conditions under which the Interconnection Customer’s Small Generating Facility will interconnect with, and operate in parallel with, the New York State Transmission System or the Distribution System.

### **1.3. Scope of Interconnection Service**

- 1.3.1. The Parties understand that the New York Independent System Operator (“NYISO”) will provide Energy Resource Interconnection Service Interconnection Service to Interconnection Customer at the Point of Interconnection.
- 1.3.2. This Agreement does not constitute an agreement to purchase or deliver the Interconnection Customer’s power. The purchase or delivery of power and other services that the Interconnection Customer may require will be covered under separate agreements, if any, or applicable provisions of NYISO’s or Connecting Transmission Owner’s tariffs. The Interconnection Customer will be responsible for separately making all necessary arrangements (including scheduling) for delivery of electricity in accordance with the applicable provisions of the NYISO OATT and Connecting Transmission Owner’s tariff. The execution of this Agreement does not constitute a request for, nor agreement to, provide energy, any Ancillary Services or Installed Capacity under the NYISO Services Tariff or any Connecting Transmission Owner’s tariff. If Interconnection Customer wishes to supply or purchase energy, Installed Capacity or Ancillary Services, then Interconnection Customer will make application to do so in accordance with the NYISO Services Tariff or Connecting Transmission Owner’s tariff.

### **1.4. Limitations**

Nothing in this Agreement is intended to affect any other agreement between Connecting Transmission Owner and the Interconnection Customer, except as otherwise expressly provided herein.

## **1.5. Responsibilities of the Parties**

- 1.5.1. The Parties shall perform all obligations of this Agreement in accordance with all Applicable Laws and Regulations, Operating Requirements, and Good Utility Practice.
- 1.5.2. The Interconnection Customer shall construct, interconnect, operate and maintain its Small Generating Facility and construct, operate, and maintain its Interconnection Facilities in accordance with the applicable manufacturer's recommended maintenance schedule, and in accordance with this Agreement, and with Good Utility Practice.
- 1.5.3. The Connecting Transmission Owner shall construct, operate, and maintain its Interconnection Facilities and Upgrades covered by this Agreement in accordance with this Agreement, and with Good Utility Practice.
- 1.5.4. The Interconnection Customer agrees to construct its facilities or systems in accordance with applicable specifications that meet or exceed those provided by the National Electrical Safety Code, the American National Standards Institute, IEEE, Underwriter's Laboratory, and Operating Requirements in effect at the time of construction and other applicable national and state codes and standards. The Interconnection Customer agrees to design, install, maintain, and operate its Small Generating Facility so as to reasonably minimize the likelihood of a disturbance adversely affecting or impairing the system or equipment of the Connecting Transmission Owner or Affected Systems.
- 1.5.5. The Connecting Transmission Owner and Interconnection Customer shall operate, maintain, repair, and inspect, and shall be fully responsible for the facilities that it now or subsequently may own, unless otherwise specified in the Attachments to this Agreement. Each Party shall be responsible for the safe installation, maintenance, repair and condition of their respective lines and appurtenances on their respective sides of the point of change of ownership. The Connecting Transmission Owner and the Interconnection Customer, as appropriate, shall provide Interconnection Facilities that adequately protect the Connecting Transmission Owner's electric system, personnel, and other persons from damage and injury. The allocation of responsibility for the design, installation, operation, maintenance and ownership of Interconnection Facilities shall be delineated in the Attachments to this Agreement.
- 1.5.6. The Connecting Transmission Owner shall cooperate with the NYISO to coordinate with all Affected Systems to support the interconnection.
- 1.5.7. The Interconnection Customer shall ensure "frequency ride through" capability and "voltage ride through" capability of its Small Generating Facility. The Interconnection Customer shall enable these capabilities such that its Small Generating Facility shall not disconnect automatically or instantaneously from the system or equipment of the Connecting Transmission Owner and any Affected

Systems for a defined under-frequency or over-frequency condition, or an under-voltage or over-voltage condition, as tested pursuant to section 2.1 of this Agreement. The defined conditions shall be in accordance with Good Utility Practice and consistent with any standards and guidelines that are applied to other generating facilities in the Balancing Authority Area on a comparable basis. The Small Generating Facility's protective equipment settings shall comply with the Transmission Owner's automatic load-shed program. The Transmission Owner shall review the protective equipment settings to confirm compliance with the automatic load-shed program. The term "ride through" as used herein shall mean the ability of a Small Generating Facility to stay connected to and synchronized with the system or equipment of the Transmission Owner and any Affected Systems during system disturbances within a range of conditions, in accordance with Good Utility Practice and consistent with any standards and guidelines that are applied to other generating facilities in the Balancing Authority on a comparable basis. The term "frequency ride through" as used herein shall mean the ability of a Small Generating Facility to stay connected to and synchronized with the system or equipment of the Transmission Owner and any Affected Systems during system disturbances within a range of under-frequency and over-frequency conditions, in accordance with Good Utility Practice and consistent with any standards and guidelines that are applied to other generating facilities in the Balancing Authority Area on a comparable basis. The term "voltage ride through" as used herein shall mean the ability of a Small Generating Facility to stay connected to and synchronized with the system or equipment of the Transmission Owner and any Affected Systems during system disturbances within a range of under-voltage and over-voltage conditions, in accordance with Good Utility Practice and consistent with any standards and guidelines that are applied to other generating facilities in the Balancing Authority Area on a comparable basis.

#### **1.6. Parallel Operation Obligations**

Once the Small Generating Facility has been authorized to commence parallel operation, the Interconnection Customer shall abide by all rules and procedures pertaining to the parallel operation of the Small Generating Facility in the applicable control area, including, but not limited to: (1) the rules and procedures concerning the operation of generation set forth in the NYISO tariffs or ISO Procedures or the Connecting Transmission Owner's tariff; (2) any requirements consistent with Good Utility Practice or that are necessary to ensure the safe and reliable operation of the Transmission System or Distribution System; and (3) the Operating Requirements set forth in Attachment 5 of this Agreement.

#### **1.7. Metering**

The Interconnection Customer shall be responsible for the Connecting Transmission Owner's reasonable and necessary cost for the purchase, installation, operation, maintenance, testing, repair, and replacement of metering and data acquisition equipment specified in Attachments 2 and 3 of this Agreement. The Interconnection Customer's metering (and data



acquisition, as required) equipment shall conform to applicable industry rules and Operating Requirements.

## **1.8. Reactive Power and Primary Frequency Response**

### **1.8.1. Power Factor Design Criteria**

1.8.1.1. Synchronous Generation. The Interconnection Customer shall design its Small Generating Facility to maintain a composite power delivery at continuous rated power output at the Point of Interconnection at a power factor within the range of 0.95 leading to 0.95 lagging, unless the NYISO or the Transmission Owner in whose Transmission District the Small Generating Facility interconnects has established different requirements that apply to all similarly situated generators in the New York Control Area or Transmission District (as applicable) on a comparable basis, in accordance with Good Utility Practice.

1.8.1.2. Non-Synchronous Generation. The Interconnection Customer shall design its Small Generating Facility to maintain a composite power delivery at continuous rated power output at the high-side of the generator substation at a power factor within the range of 0.95 leading to 0.95 lagging, unless the NYISO or the Transmission Owner in whose Transmission District the Small Generating Facility interconnects has established a different power factor range that applies to all similarly situated non-synchronous generators in the control area or Transmission District (as applicable) on a comparable basis, in accordance with Good Utility Practice. This power factor range standard shall be dynamic and can be met using, for example, power electronics designed to supply this level of reactive capability (taking into account any limitations due to voltage level, real power output, etc.) or fixed and switched capacitors, or a combination of the two. This requirement shall only apply to newly interconnecting non-synchronous generators that have not yet executed a Facilities Study Agreement as of September 21, 2016.

1.8.2. The Parties understand that the Interconnection Customer shall be paid by the NYISO for reactive power, or voltage support service, that the Interconnection Customer provides from the Small Generating Facility in accordance with Rate Schedule 2 of the NYISO Services Tariff.

~~1.8.3. Primary Frequency Response. Interconnection Customer shall ensure the primary frequency response capability of its Small Generating Facility by installing, maintaining, and operating a functioning governor or equivalent controls. The term "functioning governor or equivalent controls" as used herein shall mean the required hardware and/or software that provides frequency responsive real power control with the ability to sense changes in system frequency and autonomously adjust the Small Generating Facility's real power output in accordance with the droop and deadband parameters and in the direction needed to correct frequency deviations. Interconnection Customer is required to install a governor or equivalent controls with the capability of operating: (1) with a maximum 5~~

~~percent droop and  $\pm 0.036$  Hz deadband; or (2) in accordance with the relevant droop, deadband, and timely and sustained response settings from an approved Applicable Reliability Standard providing for equivalent or more stringent parameters. The droop characteristic shall be: (1) based on the nameplate capacity of the Small Generating Facility, and shall be linear in the range of frequencies between 59 to 61 Hz that are outside of the deadband parameter; or (2) based on an approved Applicable Reliability Standard providing for an equivalent or more stringent parameter. The deadband parameter shall be: the range of frequencies above and below nominal (60 Hz) in which the governor or equivalent controls is not expected to adjust the Small Generating Facility's real power output in response to frequency deviations. The deadband shall be implemented: (1) without a step to the droop curve, that is, once the frequency deviation exceeds the deadband parameter, the expected change in the Small Generating Facility's real power output in response to frequency deviations shall start from zero and then increase (for under frequency deviations) or decrease (for over frequency deviations) linearly in proportion to the magnitude of the frequency deviation; or (2) in accordance with an approved Applicable Reliability Standard providing for an equivalent or more stringent parameter. Interconnection Customer shall notify NYISO that the primary frequency response capability of the Small Generating Facility has been tested and confirmed during commissioning. Once Interconnection Customer has synchronized the Small Generating Facility with the New York State Transmission System, Interconnection Customer shall operate the Small Generating Facility consistent with the provisions specified in Articles 1.8.3.1 and 1.8.3.2 of this Agreement. The primary frequency response requirements contained herein shall apply to both synchronous and non-synchronous Small Generating Facilities.~~

~~1.8.3.1. Governor or Equivalent Controls. Whenever the Small Generating Facility is operated in parallel with the New York State Transmission System, Interconnection Customer shall operate the Small Generating Facility with its governor or equivalent controls in service and responsive to frequency. Interconnection Customer shall: (1) in coordination with NYISO, set the deadband parameter to: (1) a maximum of  $\pm 0.036$  Hz and set the droop parameter to a maximum of 5 percent; or (2) implement the relevant droop and deadband settings from an approved Applicable Reliability Standard that provides for equivalent or more stringent parameters. Interconnection Customer shall be required to provide the status and settings of the governor and equivalent controls to NYISO and/or the Connecting Transmission Owner upon request. If Interconnection Customer needs to operate the Small Generating Facility with its governor or equivalent controls not in service, Interconnection Customer shall immediately notify NYISO and the Connecting Transmission Owner, and provide both with the following information: (1) the operating status of the governor or equivalent controls (i.e., whether it is currently out of service or when it will be taken out of service); (2) the reasons for removing the governor or equivalent controls from service; and (3) a reasonable estimate of when the governor or equivalent controls will be returned to service. Interconnection Customer shall~~

~~make Reasonable Efforts to return its governor or equivalent controls into service as soon as practicable. Interconnection Customer shall make Reasonable Efforts to keep outages of the Small Generating Facility's governor or equivalent controls to a minimum whenever the Small Generating Facility is operated in parallel with the New York State Transmission System.~~

~~1.8.3.2. Timely and Sustained Response. Interconnection Customer shall ensure that the Small Generating Facility's real power response to sustained frequency deviations outside of the deadband setting is automatically provided and shall begin immediately after frequency deviates outside of the deadband, and to the extent the Small Generating Facility has operating capability in the direction needed to correct the frequency deviation. Interconnection Customer shall not block or otherwise inhibit the ability of the governor or equivalent controls to respond and shall ensure that the response is not inhibited, except under certain operational constraints including, but not limited to, ambient temperature limitations, physical energy limitations, outages of mechanical equipment, or regulatory requirements. The Small Generating Facility shall sustain the real power response at least until system frequency returns to a value within the deadband setting of the governor or equivalent controls. An Applicable Reliability Standard with equivalent or more stringent requirements shall supersede the above requirements.~~

~~1.8.3.3. Exemptions. Small Generating Facilities that are regulated by the United States Nuclear Regulatory Commission shall be exempt from Articles 1.8.3, 1.8.3.1, and 1.8.3.2 of this Agreement. Small Generating Facilities that are behind the meter generation that is sized to load (i.e., the thermal load and the generation are near-balanced in real-time operation and the generation is primarily controlled to maintain the unique thermal, chemical, or mechanical output necessary for the operating requirements of its host facility) shall be required to install primary frequency response capability requirements in accordance with the droop and deadband capability requirements specified in Article 1.8.3, but shall be otherwise exempt from the operating requirements in Articles 1.8.3, 1.8.3.1, 1.8.3.2, and 1.8.3.4 of this Agreement.~~

~~1.8.3.4. Electric Storage Resources. Interconnection Customer interconnecting an electric storage resource shall establish an operating range in Attachment 5 of its SGIA that specifies a minimum state of charge and a maximum state of charge between which the electric storage resource will be required to provide primary frequency response consistent with the conditions set forth in Articles 1.8.3, 1.8.3.1, 1.8.3.2, and 1.8.3.3 of this Agreement. Attachment 5 shall specify whether the operating range is static or dynamic, and shall consider (1) the expected magnitude of frequency deviations in the interconnection; (2) the expected duration that system frequency will remain outside of the deadband parameter in the interconnection; (3) the expected incidence of frequency deviations outside of the deadband parameter in the interconnection; (4) the physical capabilities of the electric storage resource; (5) operational limitations of the electric storage resources due to manufacturer specification; and (6) any other~~

~~relevant factors agreed to by the NYISO, Connecting Transmission Owner, and Interconnection Customer. If the operating range is dynamic, then Attachment 5 must establish how frequently the operating range will be reevaluated and the factors that may be considered during its reevaluation.~~

~~Interconnection Customer's electric storage resource is required to provide timely and sustained primary frequency response consistent with Article 1.8.3.2 of this Agreement when it is online and dispatched to inject electricity to the New York State Transmission System and/or receive electricity from the New York State Transmission System. This excludes circumstances when the electric storage resource is not dispatched to inject electricity to the New York State Transmission System and/or dispatched to receive electricity from the New York State Transmission System. If Interconnection Customer's electric storage resource is charging at the time of a frequency deviation outside of its deadband parameter, it is to increase (for over frequency deviations) or decrease (for under frequency deviations) the rate at which it is charging in accordance with its droop parameter. Interconnection Customer's electric storage resource is not required to change from charging to discharging, or vice versa, unless the response necessitated by the droop and deadband settings requires it to do so and it is technically capable of making such a transition.~~

## **1.9. Capitalized Terms**

Capitalized terms used herein shall have the meanings specified in the Glossary of Terms in Attachment 1 or the body of this Agreement. Capitalized terms used herein that are not so defined shall have the meanings specified in Section 32.5 or Attachment S or Attachment X of the NYISO OATT.

## **Article 2. Inspection, Testing, Authorization, and Right of Access**

### **2.1. Equipment Testing and Inspection**

- 2.1.1. The Interconnection Customer shall test and inspect its Small Generating Facility and Interconnection Facilities prior to interconnection. The Interconnection Customer shall notify the NYISO and the Connecting Transmission Owner of such activities no fewer than five Business Days (or as may be agreed to by the Parties) prior to such testing and inspection. Testing and inspection shall occur on a Business Day. The Connecting Transmission Owner may, at its own expense, send qualified personnel to the Small Generating Facility site to inspect the interconnection and observe the testing. The Interconnection Customer shall provide the NYISO and Connecting Transmission Owner a written test report when such testing and inspection is completed. The Small Generating Facility may not commence parallel operations if the NYISO, in consultation with the Connecting Transmission Owner, finds that the Small Generating Facility has not been installed as agreed upon or may not be operated in a safe and reliable manner in accordance with NYISO tariffs or ISO Procedures or the Connecting Transmission Owner's tariff or procedures.
- 2.1.2. The Connecting Transmission Owner shall, and the NYISO may, provide the Interconnection Customer written acknowledgment that it has received the Interconnection Customer's written test report. Such written acknowledgment shall not be deemed to be or construed as any representation, assurance, guarantee, or warranty by the NYISO or Connecting Transmission Owner of the safety, durability, suitability, or reliability of the Small Generating Facility or any associated control, protective, and safety devices owned or controlled by the Interconnection Customer or the quality of power produced by the Small Generating Facility.

### **2.2. Authorization Required Prior to Parallel Operation**

- 2.2.1. The Connecting Transmission Owner, in consultation with the NYISO, shall use Reasonable Efforts to list applicable parallel Operating Requirements in Attachment 5 of this Agreement. Additionally, the Connecting Transmission Owner, in consultation with the NYISO, shall notify the Interconnection Customer of any changes to these requirements as soon as they are known. The Connecting Transmission Owner shall make Reasonable Efforts to cooperate with the Interconnection Customer in meeting requirements necessary for the Interconnection Customer to commence parallel operations by the in-service date.
- 2.2.2. The Interconnection Customer shall not operate its Small Generating Facility in parallel with the New York State Transmission System or the Distribution System without prior written authorization of the NYISO. The Parties understand that the NYISO, in consultation with the Connecting Transmission Owner, will provide such authorization once the NYISO receives notification that the Interconnection

Customer has complied with all applicable parallel Operating Requirements. Such authorization shall not be unreasonably withheld, conditioned, or delayed.

### **2.3. Right of Access**

- 2.3.1. Upon reasonable notice, the NYISO and/or Connecting Transmission Owner may send a qualified person to the premises of the Interconnection Customer at or immediately before the time the Small Generating Facility first produces energy to inspect the interconnection, and observe the commissioning of the Small Generating Facility (including any required testing), startup, and operation for a period of up to three Business Days after initial start-up of the unit. In addition, the Interconnection Customer shall notify the NYISO and Connecting Transmission Owner at least five Business Days prior to conducting any on-site verification testing of the Small Generating Facility.
- 2.3.2. Following the initial inspection process described above, at reasonable hours, and upon reasonable notice, or at any time without notice in the event of an emergency or hazardous condition, the NYISO and Connecting Transmission Owner each shall have access to the Interconnection Customer's premises for any reasonable purpose in connection with the performance of the obligations imposed on them by this Agreement or if necessary to meet their legal obligation to provide service to their customers.
- 2.3.3. Each Party shall be responsible for its own costs associated with following this article.

## **Article 3. Effective Date, Term, Termination, and Disconnection**

### **3.1. Effective Date**

This Agreement shall become effective upon execution by the Parties subject to acceptance by FERC (if applicable), or if filed unexecuted, upon the date specified by the FERC. The Connecting Transmission Owner shall promptly file, or cause to be filed, this Agreement with FERC upon execution, if required. If the Agreement is disputed and the Interconnection Customer requests that it be filed with FERC in an unexecuted form, the Connecting Transmission Owner shall file, or cause to be filed, this Agreement and the Connecting Transmission Owner shall identify the disputed language.

### **3.2. Term of Agreement**

This Agreement shall become effective on the Effective Date and shall remain in effect for a period of twenty (20) years from the Effective Date and shall be automatically renewed for each successive one-year period thereafter, unless terminated earlier in accordance with article [3.3](#) of this Agreement.

### **3.3. Termination**

No termination shall become effective until the Parties have complied with all Applicable Laws and Regulations applicable to such termination, including the filing with FERC of a notice of termination of this Agreement (if required), which notice has been accepted for filing by FERC.

- 3.3.1. The Interconnection Customer may terminate this Agreement at any time by giving Connecting Transmission Owner 20 Business Days written notice. The Connecting Transmission Owner may terminate this Agreement after the Small Generating Facility is Retired.
- 3.3.2. Either Party may terminate this Agreement after Default pursuant to article [7.6](#).
- 3.3.3. Upon termination of this Agreement, the Small Generating Facility will be disconnected from the New York State Transmission System or the Distribution System, as applicable. All costs required to effectuate such disconnection shall be borne by the terminating Party, unless such termination resulted from the non-terminating Party's Default of this SGIA or such non-terminating Party otherwise is responsible for these costs under this SGIA.
- 3.3.4. The termination of this Agreement shall not relieve either Party of its liabilities and obligations, owed or continuing at the time of the termination. The Interconnection Customer shall pay all amounts in excess of any deposit or other security without interest within 30 calendar days after receipt of the invoice for such amounts. If the deposit or other security exceeds the invoice, the Connecting Transmission Owner shall refund such excess within 30 calendar days of the invoice without interest. If the Interconnection Customer disputes an amount to be paid the Interconnection Customer shall pay the disputed amount to the

Connecting Transmission Owner or into an interest bearing escrow account, pending resolution of the dispute in accordance with Article 10 of this Agreement. To the extent the dispute is resolved in the Interconnection Customer's favor, that portion of the disputed amount will be returned to the Interconnection Customer with interest at rates applicable to refunds under the Commission's regulations. To the extent the dispute is resolved in the Connecting Transmission Owner's favor, that portion of any escrowed funds and interest will be released to the Connecting Transmission Owner.

- 3.3.5. The limitations of liability, indemnification and confidentiality provisions of this Agreement shall survive termination or expiration of this Agreement.

### **3.4. Temporary Disconnection**

Temporary disconnection shall continue only for so long as reasonably necessary under Good Utility Practice.

#### **3.4.1. Emergency Conditions**

“Emergency Condition” shall mean a condition or situation: (1) that in the judgment of the Party making the claim is imminently likely to endanger life or property; or (2) that, in the case of the NYISO or Connecting Transmission Owner, is imminently likely (as determined in a non-discriminatory manner) to cause a material adverse effect on the security of, or damage to the New York State Transmission System or Distribution System, the Connecting Transmission Owner's Interconnection Facilities or the electric systems of others to which the New York State Transmission System or Distribution System is directly connected; or (3) that, in the case of the Interconnection Customer, is imminently likely (as determined in a non-discriminatory manner) to cause a material adverse effect on the security of, or damage to, the Small Generating Facility or the Interconnection Customer's Interconnection Facilities. Under Emergency Conditions, the NYISO or Connecting Transmission Owner may immediately suspend interconnection service and temporarily disconnect the Small Generating Facility. The Connecting Transmission Owner shall notify the Interconnection Customer promptly when it becomes aware of an Emergency Condition that may reasonably be expected to affect the Interconnection Customer's operation of the Small Generating Facility. The Interconnection Customer shall notify the NYISO and Connecting Transmission Owner promptly when it becomes aware of an Emergency Condition that may reasonably be expected to affect the New York State Transmission System or Distribution System or any Affected Systems. To the extent information is known, the notification shall describe the Emergency Condition, the extent of the damage or deficiency, the expected effect on the operation of each Party's facilities and operations, its anticipated duration, and the necessary corrective action.

#### **3.4.2. Routine Maintenance, Construction, and Repair**

The NYISO or Connecting Transmission Owner may interrupt interconnection service or curtail the output of the Small Generating Facility and temporarily disconnect the Small Generating Facility from the New York State Transmission System or Distribution System when necessary for routine maintenance, construction, and repairs on the New York State



Transmission System or Distribution System. NYISO or the Connecting Transmission Owner shall provide the Interconnection Customer with five (5) Business Days' notice prior to such interruption. The Connecting Transmission Owner shall use Reasonable Efforts to coordinate such reduction or temporary disconnection with the Interconnection Customer. The Parties understand that any actions the NYISO is authorized to take under this article 3.4.2 are conditioned upon the NYISO's use of Reasonable Efforts to coordinate such reduction or temporary disconnection with the Interconnection Customer.

### **3.4.3. Forced Outages**

During any forced outage, the NYISO or Connecting Transmission Owner may suspend interconnection service to the Interconnection Customer to effect immediate repairs on the New York State Transmission System or the Distribution System. The Connecting Transmission Owner shall use Reasonable Efforts to provide the Interconnection Customer with prior notice. If prior notice is not given, the Connecting Transmission Owner shall, upon request, provide the Interconnection Customer written documentation after the fact explaining the circumstances of the disconnection. The Parties understand that any suspension or disconnection the NYISO is authorized to make under this article 3.4.3 are conditioned upon: (i) the NYISO's use of Reasonable Efforts to provide the Interconnection Customer with prior notice; and (ii) if prior notice is not given, the NYISO's provision to the Interconnection Customer, upon request, of written documentation after the fact explaining the circumstances of the disconnection.

### **3.4.4. Adverse Operating Effects**

The NYISO or Connecting Transmission Owner shall notify the Interconnection Customer as soon as practicable if, based on Good Utility Practice, operation of the Small Generating Facility may cause disruption or deterioration of service to other customers served from the same electric system, or if operating the Small Generating Facility could cause damage to the New York State Transmission System, the Distribution System or Affected Systems, or if disconnection is otherwise required under Applicable Reliability Standards or the NYISO OATT. Supporting documentation used to reach the decision to disconnect shall be provided to the Interconnection Customer upon request. If, after notice, the Interconnection Customer fails to remedy the adverse operating effect within a reasonable time, the NYISO or Connecting Transmission Owner may disconnect the Small Generating Facility. The NYISO or Connecting Transmission Owner shall provide the Interconnection Customer with five Business Day notice of such disconnection, unless the provisions of article [3.4.1](#) apply.

### **3.4.5. Modification of the Small Generating Facility**

The Interconnection Customer must receive written authorization from the NYISO and Connecting Transmission Owner before making any change to the Small Generating Facility that may have a material impact on the safety or reliability of the New York State Transmission System or the Distribution System. Such authorization shall not be unreasonably withheld. Modifications shall be done in accordance with Good Utility Practice. If the Interconnection Customer makes such modification without the prior written authorization of the NYISO and Connecting Transmission Owner, the Connecting Transmission Owner shall have the right to

temporarily disconnect the Small Generating Facility. If disconnected, the Small Generating Facility will not be reconnected until the unauthorized modifications are authorized or removed.

#### **3.4.6. Reconnection**

The Parties shall cooperate with each other to restore the Small Generating Facility, Interconnection Facilities, and the New York State Transmission System and Distribution System to their normal operating state as soon as reasonably practicable following a temporary disconnection.

## **Article 4. Cost Responsibility for Interconnection Facilities and Distribution Upgrades**

### **4.1. Interconnection Facilities**

The Interconnection Customer shall pay for the cost of the Interconnection Facilities itemized in Attachment 2 of this Agreement. The Connecting Transmission Owner shall provide a best estimate cost, including overheads, for the purchase and construction of its Interconnection Facilities and provide a detailed itemization of such costs. Costs associated with Interconnection Facilities may be shared with other entities that may benefit from such facilities by agreement of the Interconnection Customer, such other entities, and the Connecting Transmission Owner.

The Interconnection Customer shall be responsible for its share of all reasonable expenses, including overheads, associated with (1) owning, operating, maintaining, repairing, and replacing its own Interconnection Facilities, and (2) operating, maintaining, repairing, and replacing the Connecting Transmission Owner's Interconnection Facilities, as set forth in Attachment 2 to this Agreement

### **4.2. Distribution Upgrades**

The Connecting Transmission Owner shall design, procure, construct, install, and own the Distribution Upgrades described in Attachment 6 of this Agreement. If the Connecting Transmission Owner and the Interconnection Customer agree, the Interconnection Customer may construct Distribution Upgrades that are located on land owned by the Interconnection Customer. The actual cost of the Distribution Upgrades, including overheads, shall be directly assigned to the Interconnection Customer. The Interconnection Customer shall be responsible for its share of all reasonable expenses, including overheads, associated with owning, operating, maintaining, repairing, and replacing the Distribution Upgrades, as set forth in Attachment 6 to this Agreement.

## **Article 5. Cost Responsibility for System Upgrade Facilities and System Deliverability Upgrades**

### **5.1. Applicability**

No portion of this article 5 shall apply unless the interconnection of the Small Generating Facility requires System Upgrade Facilities or System Deliverability Upgrades.

### **5.2. System Upgrades**

The Connecting Transmission Owner shall procure, construct, install, and own the System Upgrade Facilities and System Deliverability Upgrades described in Attachment 6 of this Agreement. To the extent that design work is necessary in addition to that already accomplished in the Class Year facilities study for the Interconnection Customer, the Connecting Transmission Owner shall perform or cause to be performed such work. If the Parties agree, the Interconnection Customer may construct System Upgrade Facilities and System Deliverability Upgrades that are located on land owned by the Interconnection Customer.

- 5.2.1. As described in Section 32.3.5.3 of the SGIP in Attachment Z of the NYISO OATT, the responsibility of the Interconnection Customer for the cost of the System Upgrade Facilities and System Deliverability Upgrades described in Attachment 6 of this Agreement shall be determined in accordance with Attachment S of the NYISO OATT, as required by Section 32.3.5.3.2 of Attachment Z. The Interconnection Customer shall be responsible for all System Upgrade Facility costs as required by Section 32.3.5.3.2 of Attachment Z or its share of any System Upgrade Facilities and System Deliverability Upgrades costs resulting from the final Attachment S process, as applicable, and Attachment 6 to this Agreement shall be revised accordingly.
- 5.2.2. Pending the outcome of the Attachment S cost allocation process, if applicable, the Interconnection Customer may elect to proceed with the interconnection of its Small Generating Facility in accordance with Section 32.3.5.3 of the SGIP.

### **5.3. Special Provisions for Affected Systems**

For the repayment of amounts advanced to Affected System Operator for System Upgrade Facilities or System Deliverability Upgrades, the Interconnection Customer and Affected System Operator shall enter into an agreement that provides for such repayment, but only if responsibility for the cost of such System Upgrade Facilities is not to be allocated in accordance with Attachment S of the NYISO OATT. The agreement shall specify the terms governing payments to be made by the Interconnection Customer to Affected System Operator as well as the repayment by Affected System Operator.

## **Article 6. Billing, Payment, Milestones, and Financial Security**

### **6.1. Billing and Payment Procedures and Final Accounting**

- 6.1.1. The Connecting Transmission Owner shall bill the Interconnection Customer for the design, engineering, construction, and procurement costs of Interconnection Facilities and Upgrades contemplated by this Agreement on a monthly basis, or as otherwise agreed by the Parties. The Interconnection Customer shall pay all invoice amounts within 30 calendar days after receipt of the invoice.
- 6.1.2. Within three months of completing the construction and installation of the Connecting Transmission Owner's Interconnection Facilities and/or Upgrades described in the Attachments to this Agreement, the Connecting Transmission Owner shall provide the Interconnection Customer with a final accounting report of any difference between (1) the Interconnection Customer's cost responsibility for the actual cost of such facilities or Upgrades, and (2) the Interconnection Customer's previous aggregate payments to the Connecting Transmission Owner for such facilities or Upgrades. If the Interconnection Customer's cost responsibility exceeds its previous aggregate payments, the Connecting Transmission Owner shall invoice the Interconnection Customer for the amount due and the Interconnection Customer shall make payment to the Connecting Transmission Owner within 30 calendar days. If the Interconnection Customer's previous aggregate payments exceed its cost responsibility under this Agreement, the Connecting Transmission Owner shall refund to the Interconnection Customer an amount equal to the difference within 30 calendar days of the final accounting report.
- 6.1.3. If the Interconnection Customer disputes an amount to be paid, the Interconnection Customer shall pay the disputed amount to the Connecting Transmission Owner or into an interest bearing escrow account, pending resolution of the dispute in accordance with Article [10](#) of this Agreement. To the extent the dispute is resolved in the Interconnection Customer's favor, that portion of the disputed amount will be credited or returned to the Interconnection Customer with interest at rates applicable to refunds under the Commission's regulations. To the extent the dispute is resolved in the Connecting Transmission Owner's favor, that portion of any escrowed funds and interest will be released to the Connecting Transmission Owner.

### **6.2. Milestones**

Subject to the provisions of the SGIP, the Parties shall agree on milestones for which each Party is responsible and list them in Attachment 4 of this Agreement. A Party's obligations under this provision may be extended by agreement. If a Party anticipates that it will be unable to meet a milestone for any reason other than a Force Majeure event, it shall immediately notify the other Party of the reason(s) for not meeting the milestone and (1) propose the earliest reasonable alternate date by which it can attain this and future milestones, and (2) requesting appropriate amendments to Attachment 4. The Party affected by the failure to meet a milestone

shall not unreasonably withhold agreement to such an amendment unless: (1) it will suffer significant uncompensated economic or operational harm from the delay, (2) attainment of the same milestone has previously been delayed, or (3) it has reason to believe that the delay in meeting the milestone is intentional or unwarranted notwithstanding the circumstances explained by the Party proposing the amendment.

### **6.3. Financial Security Arrangements**

At least 20 Business Days prior to the commencement of the design, procurement, installation, or construction of a discrete portion of the Connecting Transmission Owner's Interconnection Facilities and Upgrades, the Interconnection Customer shall provide the Connecting Transmission Owner, at the Interconnection Customer's option, a guarantee, a surety bond, letter of credit or other form of security that is reasonably acceptable to the Connecting Transmission Owner and is consistent with the Uniform Commercial Code of the jurisdiction where the Point of Interconnection is located. Such security for payment shall be in an amount sufficient to cover the costs for constructing, designing, procuring, and installing the applicable portion of the Connecting Transmission Owner's Interconnection Facilities and Upgrades and shall be reduced on a dollar-for-dollar basis for payments made to the Connecting Transmission Owner under this Agreement during its term. The Connecting Transmission Owner may draw on any such security to the extent that the Interconnection Customer fails to make any payments due under this Agreement. In addition:

- 6.3.1. The guarantee must be made by an entity that meets the creditworthiness requirements of the Connecting Transmission Owner, and contain terms and conditions that guarantee payment of any amount that may be due from the Interconnection Customer, up to an agreed-to maximum amount.
- 6.3.2. The letter of credit or surety bond must be issued by a financial institution or insurer reasonably acceptable to the Connecting Transmission Owner and must specify a reasonable expiration date.
- 6.3.3. Notwithstanding the above, Security posted for System Upgrade Facilities for a Small Generating Facility required to enter the Class Year process, or cash or Security provided for System Deliverability Upgrades, shall meet the requirements for Security contained in Attachment S to the NYISO OATT.

## **Article 7. Assignment, Liability, Indemnity, Force Majeure, Consequential Damages, and Default**

### **7.1. Assignment**

This Agreement, and each and every term and condition hereof, shall be binding upon and inure to the benefit of the Parties hereto and their respective successors and assigns. This Agreement may be assigned by either Party upon 15 Business Days prior written notice and opportunity to object by the other Party; provided that:

- 7.1.1. A Party may assign this Agreement without the consent of the other Party to any affiliate of the assigning Party with an equal or greater credit rating and with the legal authority and operational ability to satisfy the obligations of the assigning Party under this Agreement, provided that the Interconnection Customer promptly notifies the Connecting Transmission Owner of any such assignment. A Party may assign this Agreement without the consent of the other Party in connection with the sale, merger, restructuring, or transfer of a substantial portion of all of its assets, including the Interconnection Facilities it owns, so long as the assignee in such a transaction directly assumes all rights, duties and obligation arising under this Agreement.
- 7.1.2. The Interconnection Customer shall have the right to assign this Agreement, without the consent of the Connecting Transmission Owner, for collateral security purposes to aid in providing financing for the Small Generating Facility.
- 7.1.3. Any attempted assignment that violates this article is void and ineffective. Assignment shall not relieve a Party of its obligations, nor shall a Party's obligations be enlarged, in whole or in part, by reason thereof. An assignee is responsible for meeting the same financial, credit, and insurance obligations as the Interconnection Customer. Where required, consent to assignment will not be unreasonably withheld, conditioned or delayed.

### **7.2. Limitation of Liability**

Each Party's liability to the other Party for any loss, cost, claim, injury, liability, or expense, including reasonable attorney's fees, relating to or arising from any act or omission in its performance of this Agreement, shall be limited to the amount of direct damage actually incurred. In no event shall either Party be liable to the other Party for any indirect, special, consequential, or punitive damages.

### **7.3. Indemnity**

- 7.3.1. This provision protects each Party from liability incurred to third parties as a result of carrying out the provisions of this Agreement. Liability under this provision is exempt from the general limitations on liability found in article [7.2](#).
- 7.3.2. Each Party (the "Indemnifying Party") shall at all times indemnify, defend, and hold harmless the other Party (the "Indemnified Party") from, any and all

damages, losses, claims, including claims and actions relating to injury to or death of any person or damage to property, the alleged violation of any Environmental Law, or the release or threatened release of any Hazardous Substance, demand, suits, recoveries, costs and expenses, court costs, attorney fees, and all other obligations by or to third parties (any and all of these a “Loss”), arising out of or resulting from (i) the Indemnified Party’s performance under this Agreement on behalf of the Indemnifying Party, except in cases where the Indemnifying Party can demonstrate that the Loss of the Indemnified Party was caused by the gross negligence or intentional wrongdoing by the Indemnified Party or (ii) the violation by the Indemnifying Party of any Environmental Law or the release by the Indemnifying Party of a Hazardous Substance.

- 7.3.3. If a Party is entitled to indemnification under this article as a result of a claim by a third party, and the Indemnifying Party fails, after notice and reasonable opportunity to proceed under this article, to assume the defense of such claim, such Indemnified Party may at the expense of the Indemnifying Party contest, settle or consent to the entry of any judgment with respect to, or pay in full, such claim.
- 7.3.4. If an Indemnifying Party is obligated to indemnify and hold an Indemnified Party harmless under this article, the amount owing to the Indemnified Party shall be the amount of such Indemnified Party’s actual loss, net of any insurance or other recovery.
- 7.3.5. Promptly after receipt by an Indemnified Party of any claim or notice of the commencement of any action or administrative or legal proceeding or investigation as to which the indemnity provided for in this article may apply, the Indemnified Party shall notify the Indemnifying Party of such fact. Any failure of or delay in such notification shall not affect a Party’s indemnification obligation unless such failure or delay is materially prejudicial to the Indemnifying Party.

#### **7.4. Consequential Damages**

Other than as expressly provided for in this Agreement, no Party shall be liable under any provision of this Agreement for any losses, damages, costs or expenses for any special, indirect, incidental, consequential, or punitive damages, including but not limited to loss of profit or revenue, loss of the use of equipment, cost of capital, cost of temporary equipment or services, whether based in whole or in part in contract, in tort, including negligence, strict liability, or any other theory of liability; provided, however, that damages for which a Party may be liable to the other Party under another agreement will not be considered to be special, indirect, incidental, or consequential damages hereunder..

#### **7.5. Force Majeure**

- 7.5.1. As used in this article, a Force Majeure Event shall mean “any act of God, labor disturbance, act of the public enemy, war, insurrection, riot, fire, storm or flood, explosion, breakage or accident to machinery or equipment, any order, regulation



or restriction imposed by governmental, military or lawfully established civilian authorities, or any other cause beyond a Party's control. A Force Majeure Event does not include an act of negligence or intentional wrongdoing." For the purposes of this article, this definition of Force Majeure shall supersede the definitions of Force Majeure set out in Section 32.10.1 of the NYISO OATT.

- 7.5.2. If an event of Force Majeure prevents a Party from fulfilling any obligations under this Agreement, the Party affected by the Force Majeure event (Affected Party) shall promptly notify the other Party, either in writing or via the telephone, of the existence of the Force Majeure event. The notification must specify in reasonable detail the circumstances of the Force Majeure event, its expected duration, and the steps that the Affected Party is taking to mitigate the effects of the event on its performance. The Affected Party shall keep the other Party informed on a continuing basis of developments relating to the Force Majeure event until the event ends. The Affected Party will be entitled to suspend or modify its performance of obligations under this Agreement (other than the obligation to make payments) only to the extent that the effect of the Force Majeure event cannot be mitigated by the use of Reasonable Efforts. The Affected Party will use Reasonable Efforts to resume its performance as soon as possible.

## **7.6. Breach and Default**

- 7.6.1. No Breach of this Agreement shall exist where such failure to discharge an obligation (other than the payment of money) is the result of a Force Majeure event or the result of an act or omission of the other Party. Upon a Breach, the non-breaching Party shall give written notice of such Breach to the Breaching Party. Except as provided in article [7.6.2](#), the Breaching Party shall have 60 calendar days from receipt of the Breach notice within which to cure such Breach; provided however, if such Breach is not capable of cure within 60 calendar days, the Breaching Party shall commence such cure within 20 calendar days after notice and continuously and diligently complete such cure within six months from receipt of the Breach notice; and, if cured within such time, the Breach specified in such notice shall cease to exist.
- 7.6.2. If a Breach is not cured as provided in this article, or if a Breach is not capable of being cured within the period provided for herein, a Default shall exist and the non-defaulting Party shall thereafter have the right to terminate this Agreement, in accordance with article [3.3](#) hereof, by written notice to the Defaulting Party at any time until cure occurs, and be relieved of any further obligation hereunder and, whether or not that Party terminates this Agreement, to recover from the Defaulting Party all amounts due hereunder, plus all other damages and remedies to which they are entitled at law or in equity. The provisions of this article shall survive termination of this Agreement.
- 7.6.3. In cases where the Interconnection Customer has elected to proceed under Section 32.3.5.3 of the SGIP, if the Interconnection Request is withdrawn or

deemed withdrawn pursuant to the SGIP during the term of this Agreement, this Agreement shall terminate.

## **Article 8. Insurance**

- 8.1.** The Interconnection Customer shall, at its own expense, maintain in force general liability insurance without any exclusion for liabilities related to the interconnection undertaken pursuant to this Agreement. The amount of such insurance shall be sufficient to insure against all reasonably foreseeable direct liabilities given the size and nature of the generating equipment being interconnected, the interconnection itself, and the characteristics of the system to which the interconnection is made. Such insurance coverage is specified in Attachment [7](#) to this Agreement. The Interconnection Customer shall obtain additional insurance only if necessary as a function of owning and operating a generating facility. Such insurance shall be obtained from an insurance provider authorized to do business in New York State where the interconnection is located. Certification that such insurance is in effect shall be provided upon request of the Connecting Transmission Owner, except that the Interconnection Customer shall show proof of insurance to the Connecting Transmission Owner no later than ten Business Days prior to the anticipated commercial operation date. An Interconnection Customer of sufficient creditworthiness may propose to self-insure for such liabilities, and such a proposal shall not be unreasonably rejected.
- 8.2.** Connecting Transmission Owner agrees to maintain general liability insurance or self-insurance consistent with the existing commercial practice. Such insurance or self-insurance shall not exclude the liabilities undertaken pursuant to this Agreement.
- 8.3.** The Parties further agree to notify one another whenever an accident or incident occurs resulting in any injuries or damages that are included within the scope of coverage of such insurance, whether or not such coverage is sought.

## **Article 9. Confidentiality**

- 9.1.** Confidential Information shall mean any confidential and/or proprietary information provided by one Party to the other Party that is clearly marked or otherwise designated “Confidential.” For purposes of this Agreement all design, operating specifications, and metering data provided by the Interconnection Customer shall be deemed Confidential Information regardless of whether it is clearly marked or otherwise designated as such. Confidential Information shall include, without limitation, information designated as such by the NYISO Code of Conduct contained in Attachment F to the NYISO OATT.
- 9.2.** Confidential Information does not include information previously in the public domain, required to be publicly submitted or divulged by Governmental Authorities (after notice to the other Party and after exhausting any opportunity to oppose such publication or release), or necessary to be divulged in an action to enforce this Agreement. Each Party receiving Confidential Information shall hold such information in confidence and shall not disclose it to any third party nor to the public without the prior written authorization from the Party providing that information, except to fulfill obligations under this Agreement, or to fulfill legal or regulatory requirements.
- 9.2.1. Each Party shall employ at least the same standard of care to protect Confidential Information obtained from the other Party as it employs to protect its own Confidential Information.
- 9.2.2. Each Party is entitled to equitable relief, by injunction or otherwise, to enforce its rights under this provision to prevent the release of Confidential Information without bond or proof of damages, and may seek other remedies available at law or in equity for breach of this provision.
- 9.3.** Notwithstanding anything in this article to the contrary, and pursuant to 18 CFR § 1b.20, if FERC, during the course of an investigation or otherwise, requests information from the other Party that is otherwise required to be maintained in confidence pursuant to this Agreement, the Party shall provide the requested information to FERC, within the time provided for in the request for information. In providing the information to FERC, the Party may, consistent with 18 CFR § 388.112, request that the information be treated as confidential and non-public by FERC and that the information be withheld from public disclosure. Each Party is prohibited from notifying the other Party to this Agreement prior to the release of the Confidential Information to FERC. The Party shall notify the other Party to this Agreement when it is notified by FERC that a request to release Confidential Information has been received by FERC, at which time either of the Parties may respond before such information would be made public, pursuant to 18 CFR § 388.112. Requests from a state regulatory body conducting a confidential investigation shall be treated in a similar manner if consistent with the applicable state rules and regulations.
- 9.4.** Consistent with the provisions of this article [9](#), the Parties to this Agreement will cooperate in good faith to provide each other, Affected Systems, Affected System

Operators, and state and federal regulators the information necessary to carry out the terms of the SGIP and this Agreement.

## **Article 10. Disputes**

- 10.1.** The Connecting Transmission Owner and Interconnection Customer agree to attempt to resolve all disputes arising out of the interconnection process according to the provisions of this article.
- 10.2.** In the event of a dispute, the Parties will first attempt to promptly resolve it on an informal basis. If the Parties cannot promptly resolve the dispute on an informal basis, then either Party shall provide the other Party with a written Notice of Dispute. Such Notice shall describe in detail the nature of the dispute.
- 10.3.** If the dispute has not been resolved within two Business Days after receipt of the Notice, either Party may contact FERC's Dispute Resolution Service (DRS) for assistance in resolving the dispute.
- 10.4.** The DRS will assist the Parties in either resolving their dispute or in selecting an appropriate dispute resolution venue (e.g., mediation, settlement judge, early neutral evaluation, or technical expert) to assist the Parties in resolving their dispute. The result of this dispute resolution process will be binding only if the Parties agree in advance. DRS can be reached at 1-877-337-2237 or via the internet at <http://www.ferc.gov/legal/adr.asp>.
- 10.5.** Each Party agrees to conduct all negotiations in good faith and will be responsible for one-half of any costs paid to neutral third-parties.
- 10.6.** If either Party elects to seek assistance from the DRS, or if the attempted dispute resolution fails, then either Party may exercise whatever rights and remedies it may have in equity or law consistent with the terms of this Agreement.

## **Article 11. Taxes**

- 11.1.** The Parties agree to follow all applicable tax laws and regulations, consistent with FERC policy and Internal Revenue Service requirements.
- 11.2.** Each Party shall cooperate with the other Party to maintain the other Party's tax status. Nothing in this Agreement is intended to adversely affect the tax status of either Party or the status of any Connecting Transmission Owner with respect to the issuance of bonds including, but not limited to, Local Furnishing Bonds. Notwithstanding any other provisions of this Agreement, LIPA, NYPA and Consolidated Edison Company of New York, Inc. shall not be required to comply with any provisions of this Agreement that would result in the loss of tax-exempt status of any of their Tax-Exempt Bonds or impair their ability to issue future tax-exempt obligations. For purposes of this provision, Tax-Exempt Bonds shall include the obligations of the Long Island Power Authority, NYPA and Consolidated Edison Company of New York, Inc., the interest on which is not included in gross income under the Internal Revenue Code.
- 11.3.** LIPA and NYPA do not waive their exemptions, pursuant to Section 201(f) of the FPA, from Commission jurisdiction with respect to the Commission's exercise of the FPA's general ratemaking authority.
- 11.4.** Any payments due to the Connecting Transmission Owner under this Agreement shall be adjusted to include any tax liability incurred by the Connecting Transmission Owner with respect to the interconnection request which is the subject of this Agreement. Such adjustments shall be made in accordance with the provisions of Article 5.17 of the LGIA in Attachment X of the NYISO OATT. Except where otherwise noted, all costs, deposits, financial obligations and the like specified in this Agreement shall be assumed not to reflect the impact of applicable taxes.

## **Article 12. Miscellaneous**

### **12.1. Governing Law, Regulatory Authority, and Rules**

The validity, interpretation and enforcement of this Agreement and each of its provisions shall be governed by the laws of the state of New York, without regard to its conflicts of law principles. This Agreement is subject to all Applicable Laws and Regulations. Each Party expressly reserves the right to seek changes in, appeal, or otherwise contest any laws, orders, or regulations of a Governmental Authority.

### **12.2. Amendment**

The Parties may amend this Agreement by a written instrument duly executed by the Parties, or under article [12.12](#) of this Agreement.

### **12.3. No Third-Party Beneficiaries**

This Agreement is not intended to and does not create rights, remedies, or benefits of any character whatsoever in favor of any persons, corporations, associations, or entities other than the Parties, and the obligations herein assumed are solely for the use and benefit of the Parties, their successors in interest and where permitted, their assigns. Notwithstanding the foregoing, any subcontractor of the Connecting Transmission Owner assisting that Party with the Interconnection Request covered by this Agreement shall be entitled to the benefits of indemnification provided for under Article [7.3](#) of this Agreement and the limitation of liability provided for in Article [7.2](#) of this Agreement.

### **12.4. Waiver**

12.4.1. The failure of a Party to this Agreement to insist, on any occasion, upon strict performance of any provision of this Agreement will not be considered a waiver of any obligation, right, or duty of, or imposed upon, such Party.

12.4.2. Any waiver at any time by a Party of its rights with respect to this Agreement shall not be deemed a continuing waiver or a waiver with respect to any other failure to comply with any other obligation, right, duty of this Agreement. Termination or default of this Agreement for any reason by Interconnection Customer shall not constitute a waiver of the Interconnection Customer's legal rights to obtain an interconnection from the NYISO. Any waiver of this Agreement shall, if requested, be provided in writing.

### **12.5. Entire Agreement**

This Agreement, including all Attachments, constitutes the entire agreement between the Parties with reference to the subject matter hereof, and supersedes all prior and contemporaneous understandings or agreements, oral or written, between the Parties with respect to the subject matter of this Agreement. There are no other agreements, representations, warranties, or covenants which constitute any part of the consideration for, or any condition to, either Party's compliance with its obligations under this Agreement.



## **12.6. Multiple Counterparts**

This Agreement may be executed in two or more counterparts, each of which is deemed an original but all constitute one and the same instrument.

## **12.7. No Partnership**

This Agreement shall not be interpreted or construed to create an association, joint venture, agency relationship, or partnership between the Parties or to impose any partnership obligation or partnership liability upon either Party. No Party shall have any right, power or authority to enter into any agreement or undertaking for, or act on behalf of, or to act as or be an agent or representative of, or to otherwise bind, the other Party.

## **12.8. Severability**

If any provision or portion of this Agreement shall for any reason be held or adjudged to be invalid or illegal or unenforceable by any court of competent jurisdiction or other Governmental Authority, (1) such portion or provision shall be deemed separate and independent, (2) the Parties shall negotiate in good faith to restore insofar as practicable the benefits to each Party that were affected by such ruling, and (3) the remainder of this Agreement shall remain in full force and effect.

## **12.9. Security Arrangements**

Infrastructure security of electric system equipment and operations and control hardware and software is essential to ensure day-to-day reliability and operational security. FERC expects the NYISO, the Connecting Transmission Owner, Market Participants, and Interconnection Customers interconnected to electric systems to comply with the recommendations offered by the President's Critical Infrastructure Protection Board and, eventually, best practice recommendations from the electric reliability authority. All public utilities are expected to meet basic standards for system infrastructure and operational security, including physical, operational, and cyber-security practices.

## **12.10. Environmental Releases**

Each Party shall notify the other Party, first orally and then in writing, of the release of any hazardous substances, any asbestos or lead abatement activities, or any type of remediation activities related to the Small Generating Facility or the Interconnection Facilities, each of which may reasonably be expected to affect the other Party. The notifying Party shall (1) provide the notice as soon as practicable, provided such Party makes a good faith effort to provide the notice no later than 24 hours after such Party becomes aware of the occurrence, and (2) promptly furnish to the other Party copies of any publicly available reports filed with any governmental authorities addressing such events.

## **12.11. Subcontractors**

Nothing in this Agreement shall prevent a Party from utilizing the services of any subcontractor as it deems appropriate to perform its obligations under this Agreement; provided,

however, that each Party shall require its subcontractors to comply with all applicable terms and conditions of this Agreement in providing such services and each Party shall remain primarily liable to the other Party for the performance of such subcontractor.

12.11.1. The creation of any subcontract relationship shall not relieve the hiring Party of any of its obligations under this Agreement. The hiring Party shall be fully responsible to the other Party to the extent provided for in Sections 32.7.2 and 32.7.3 above for the acts or omissions of any subcontractor the hiring Party hires as if no subcontract had been made; provided, however, that in no event shall Connecting Transmission Owner be liable for the actions or inactions of the Interconnection Customer or its subcontractors with respect to obligations of the Interconnection Customer under this Agreement. Any applicable obligation imposed by this Agreement upon the hiring Party shall be equally binding upon, and shall be construed as having application to, any subcontractor of such Party.

12.11.2. The obligations under this article will not be limited in any way by any limitation of subcontractor's insurance.

## **12.12. Reservation of Rights**

Nothing in this Agreement shall alter the right of Connecting Transmission Owner to make unilateral filings with FERC to modify this Agreement with respect to any rates, terms and conditions, charges, classifications of service, rule or regulation under Section 205 or any other applicable provision of the Federal Power Act and FERC's rules and regulations thereunder which rights are expressly reserved herein, and the existing rights of the Interconnection Customer to make a unilateral filing with FERC to modify this Agreement under any applicable provision of the Federal Power Act and FERC's rules and regulations are also expressly reserved herein; provided that each Party shall have the right to protest any such filing by the other Party and to participate fully in any proceeding before FERC in which such modifications may be considered. Nothing in this Agreement shall limit the rights of the Parties or of FERC under Sections 205 or 206 of the Federal Power Act and FERC's rules and regulations, except to the extent that the Parties otherwise agree as provided herein.

## **Article 13. Notices**

### **13.1. General**

Unless otherwise provided in this Agreement, any written notice, demand, or request required or authorized in connection with this Agreement (“Notice”) shall be deemed properly given if delivered in person, delivered by recognized national carrier service, or sent by first class mail, postage prepaid, to the person specified below:

If to the Interconnection Customer:

GR Catalyst Two LLC  
Attention: General Counsel  
Address: 1401 Walnut Street, Suite 420  
City: Boulder State: Colorado Zip: 80302  
Phone: 303-615-3104  
Fax: 720-420-9956

If to the Connecting Transmission Owner:

Niagara Mohawk Power Corporation d/b/a/ National Grid  
Attention: Kathryn Cox-Arslan, Director, Transmission Commercial  
Address: 40 Sylvan Road  
City: Waltham State: MA Zip: 02451  
Phone: (781) 907-2422  
Fax: (781) 907-5707  
E-mail: Kathryn.cox-arслан@nationalgrid.com

If to the NYISO:

Attention: Vice President, Operations  
Address: New York Independent System Operator, Inc., 3890 Carman Road  
City: Schenectady State: NY Zip: 12303  
Phone: (518) 356-6000  
Fax: (518) 356-6118

### **13.2. Billing and Payment**

Billings and payments shall be sent to the addresses set out below:

Interconnection Customer: GR Catalyst Two LLC

Attention: Accounting Manager  
Address: 1401 Walnut Street, Suite 420  
City: Boulder State: Colorado Zip: 80302

Connecting Transmission Owner: Niagara Mohawk Corporation d/b/a National Grid

Attention: Kathryn Cox-Arslan, Director, Transmission Commercial  
Address: 40 Sylvan Road  
City: Waltham State: MA Zip: 02451  
E-mail: Kathryn.cox-arslan@nationalgrid.com

### **13.3. Alternative Forms of Notice**

Any notice or request required or permitted to be given by either Party to the other and not required by this Agreement to be given in writing may be so given by telephone, facsimile or e-mail to the telephone numbers and e-mail addresses set out below:

If to the Interconnection Customer:

GR Catalyst Two LLC  
Attention: General Counsel  
Address: 1401 Walnut Street, Suite 420  
City: Boulder State: Colorado Zip: 80302  
Phone: 303-615-3104  
Fax: 720-420-9956

If to the Connecting Transmission Owner:

Niagara Mohawk Power Corporation d/b/a National Grid  
Attention: Kathryn Cox-Arslan, Director, Transmission Commercial  
Address: 40 Sylvan Road  
City: Waltham State: MA Zip: 02451  
Phone: (781) 907-2422  
Fax: (781) 907-5707  
E-mail: Kathryn.cox-Arslan@nationalgrid.com

If to the NYISO:

Attention: Vice President, Operations  
Address: New York Independent System Operator, Inc., 3890 Carman Road  
City: Schenectady State: NY Zip: 12303  
Phone: (518) 356-6000  
Fax: (518) 356-6118

### **13.4. Designated Operating Representative**

The Parties may also designate operating representatives to conduct the communications which may be necessary or convenient for the administration of this Agreement. This person will also serve as the point of contact with respect to operations and maintenance of the Party's facilities.

Interconnection Customer's Operating Representative:

GR Catalyst Two LLC  
Attention: Jim Fulmer  
Address: 1401 Walnut Street, Suite 420  
City: Boulder State: Colorado Zip: 80302  
Phone: 864-704-6760  
Fax: 720-420-9956

Connecting Transmission Owner's Operating Representative:

Niagara Mohawk Corporation d/b/a  
National Grid  
Attention: ERCC Shift Supervisor  
Address: 5215 Western Turnpike  
City: Altamont State: NY Zip: 12009  
Phone: (518) 356-6471

NYISO's Operating Representative:

Attention: Vice President, Operations  
Address: New York Independent System Operator, Inc., 3890 Carman Road  
City: Schenectady State: NY Zip: 12303  
Phone: (518) 356-6000  
Fax: (518) 356-6118

**13.5. Changes to the Notice Information**

Either Party may change this information by giving five Business Days written notice prior to the effective date of the change.

**Article 14. Signatures**

IN WITNESS WHEREOF, the Parties have caused this Agreement to be executed by their respective duly authorized representatives.

**For Niagara Mohawk Power Corporation d/b/a National Grid**

Name:   
Title: Director, Commercial Services  
Date: November 26, 2019

**For GR Catalyst Two LLC**

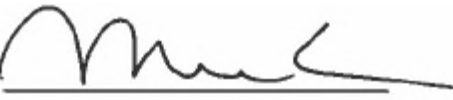
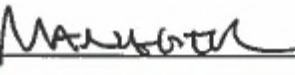
Name:   
Title:   
Date: November 26, 2019

## Attachment 1

### Glossary of Terms

**Affected System** – An electric system other than the transmission system owned, controlled or operated by the Connecting Transmission Owner that may be affected by the proposed interconnection.

**Affected System Operator** – Affected System Operator shall mean the operator of any Affected System.

**Affected Transmission Owner** -- The New York public utility or authority (or its designated agent) other than the Connecting Transmission Owner that (i) owns facilities used for the transmission of Energy in interstate commerce and provides Transmission Service under the Tariff, and (ii) owns, leases or otherwise possesses an interest in a portion of the New York State Transmission System where System Deliverability Upgrades or System Upgrade Facilities are installed pursuant to Attachment Z and Attachment S to the NYISO OATT.

**Applicable Laws and Regulations** – All duly promulgated applicable federal, state and local laws, regulations, rules, ordinances, codes, decrees, judgments, directives, or judicial or administrative orders, permits and other duly authorized actions of any Governmental Authority, including but not limited to Environmental Law.

**Applicable Reliability Standards** – The criteria, requirements and guidelines of the North American Electric Reliability Council, the Northeast Power Coordinating Council, the New York State Reliability Council and related and successor organizations, or the Transmission District to which the Interconnection Customer's Small Generating Facility is directly interconnected, as those criteria, requirements and guidelines are amended and modified and in effect from time to time; provided that no Party shall waive its right to challenge the applicability of or validity of any criterion, requirement or guideline as applied to it in the context of Attachment Z to the NYISO OATT and this Agreement. For the purposes of this Agreement, this definition of Applicable Reliability Standards shall supersede the definition of Applicable Reliability Standards set out in Attachment X to the NYISO OATT.

**Base Case** -- The base case power flow, short circuit, and stability data bases used for the Interconnection Studies by NYISO, Connecting Transmission Owner or Interconnection Customer; described in Section 32.2.3 of the Large Facility Interconnection Procedures.

**Breach** - The failure of a Party to perform or observe any material term or condition of this Agreement.

**Business Day** – Monday through Friday, excluding federal holidays.

**Capacity Resource Interconnection Service** - The service provided by NYISO to Interconnection Customers that satisfy the NYISO Deliverability Interconnection Standard or that are otherwise eligible to receive CRIS in accordance with Attachment S to the ISO OATT; such service being one of the eligibility requirements for participation as a NYISO Installed Capacity Supplier.

**Connecting Transmission Owner** – The New York public utility or authority (or its designated agent) that (i) owns facilities used for the transmission of Energy in interstate commerce and provides Transmission Service under the Tariff, (ii) owns, leases or otherwise possesses an interest in the portion of the New York State Transmission System or Distribution System at the Point of Interconnection, and (iii) is a Party to this SGIA.

**Deliverability Interconnection Standard** – The standard that must be met by any Small Generating Facility larger than 2MW proposing to interconnect to the New York State Transmission System or Distribution System and to become a qualified Installed Capacity Supplier, and must be met by any merchant transmission project proposing to interconnect to the New York State Transmission System and receive Unforced Capacity Delivery Rights. To meet the NYISO Deliverability Interconnection Standard, the Interconnection Customer must, in accordance with the rules in Attachment S to the NYISO OATT, fund or commit to fund the System Deliverability Upgrades identified for its project in the Class Year Deliverability Study.

**Default** – The failure of a Party in Breach of this Agreement to cure such Breach under this SGIA.

**Distribution System** - The Transmission Owner's facilities and equipment used to distribute electricity that are subject to FERC jurisdiction, and are subject to the NYISO's Large Facility Interconnection Procedures in Attachment X to the ISO OATT or Small Generator Interconnection Procedures in Attachment Z to the ISO OATT under FERC Order Nos. 2003 and/or 2006. For the purpose of this Agreement, the term Distribution System shall not include LIPA's distribution facilities.

**Distribution Upgrades** – The additions, modifications, and upgrades to the Connecting Transmission Owner's Distribution System at or beyond the Point of Interconnection to facilitate interconnection of the Small Generating Facility and render the transmission service necessary to effect the Interconnection Customer's wholesale sale of electricity in interstate commerce. Distribution Upgrades do not include Interconnection Facilities or System Upgrade Facilities or System Deliverability Upgrades.

**Energy Resource Interconnection Service** – The service provided by NYISO to interconnect the Interconnection Customer's Small Generating Facility to the New York State Transmission System or Distribution System in accordance with the NYISO Minimum Interconnection Standard, to enable the New York State Transmission System to receive Energy and Ancillary Services from the Small Generating Facility, pursuant to the terms of the NYISO OATT.

**Force Majeure** – Any act of God, labor disturbance, act of the public enemy, war, insurrection, riot, fire, storm or flood, explosion, breakage or accident to machinery or equipment, any order, regulation or restriction imposed by governmental, military or lawfully established civilian authorities, or any other cause beyond a Party's control. A Force Majeure event does not include an act of negligence or intentional wrongdoing. For the purposes of this Agreement, this definition of Force Majeure shall supersede the definitions of Force Majeure set out in Section 32.2.11 of the NYISO Open Access Transmission Tariff.



**Good Utility Practice** – Any of the practices, methods and acts engaged in or approved by a significant portion of the electric industry during the relevant time period, or any of the practices, methods and acts which, in the exercise of reasonable judgment in light of the facts known at the time the decision was made, could have been expected to accomplish the desired result at a reasonable cost consistent with good business practices, reliability, safety and expedition. Good Utility Practice is not intended to be limited to the optimum practice, method, or act to the exclusion of all others, but rather to be acceptable practices, methods, or acts generally accepted in the region.

**Governmental Authority** – Any federal, state, local or other governmental regulatory or administrative agency, court, commission, department, board, or other governmental subdivision, legislature, rulemaking board, tribunal, or other governmental authority having jurisdiction over the Parties, their respective facilities, or the respective services they provide, and exercising or entitled to exercise any administrative, executive, police, or taxing authority or power; provided, however, that such term does not include the Interconnection Customer, NYISO, Affected Transmission Owner, Connecting Transmission Owner or any Affiliate thereof.

**Interconnection Customer** – Any entity, including the Transmission Owner or any of the affiliates or subsidiaries, that proposes to interconnect its Small Generating Facility with the New York State Transmission System or the Distribution System.

**Interconnection Facilities** – The Connecting Transmission Owner’s Interconnection Facilities and the Interconnection Customer’s Interconnection Facilities. Collectively, Interconnection Facilities include all facilities and equipment between the Small Generating Facility and the Point of Interconnection, including any modification, additions or upgrades that are necessary to physically and electrically interconnect the Small Generating Facility to the New York State Transmission System or the Distribution System. Interconnection Facilities are sole use facilities and shall not include Distribution Upgrades or System Upgrade Facilities.

**Interconnection Request** – The Interconnection Customer’s request, in accordance with the Tariff, to interconnect a new Small Generating Facility, or to materially increase the capacity of, or make a material modification to the operating characteristics of, an existing Small Generating Facility that is interconnected with the New York State Transmission System or the Distribution System. For the purposes of this Agreement, this definition of Interconnection Request shall supersede the definition of Interconnection Request set out in Attachment X to the NYISO OATT.

**Interconnection Study** – Any study required to be performed under Sections 32.2 or 32.3 of the SGIP.

**Material Modification** – A modification that has a material impact on the cost or timing of any Interconnection Request with a later queue priority date.

**Minimum Interconnection Standard** – The reliability standard that must be met by any Small Generating Facility proposing to connect to the New York State Transmission System or Distribution System. The Standard is designed to ensure reliable access by the proposed project

to the New York State Transmission System. The Standard does not impose any deliverability test or deliverability requirement on the proposed interconnection.

**New York State Transmission System** –shall mean the entire New York State electric transmission system, which includes: (i) the Transmission Facilities under ISO Operational Control; (ii) the Transmission Facilities Requiring ISO Notification; and (iii) all remaining transmission facilities within the New York Control Area.

**NYISO Deliverability Interconnection Standard** - The standard that must be met, unless otherwise provided for by Attachment S to the ISO OATT, by (i) any generation facility larger than 2 MW in order for that facility to obtain CRIS; (ii) any Class Year Transmission Project proposing to interconnect to the New York State Transmission System and receive Unforced Capacity Delivery Rights; (iii) any entity requesting External CRIS Rights, and (iv) any entity requesting a CRIS transfer pursuant to Section 25.9.5 of Attachment S to the ISO OATT. To meet the NYISO Deliverability Interconnection Standard, the Interconnection Customer must, in accordance with the rules in Attachment S to the ISO OATT, fund or commit to fund any System Deliverability Upgrades identified for its project in the Class Year Deliverability Study.

**Operating Requirements** – Any operating and technical requirements that may be applicable due to Regional Transmission Organization, Independent System Operator, control area, or the Connecting Transmission Owner’s requirements, including those set forth in this SGIA. Operating Requirements shall include Applicable Reliability Standards.

**Party or Parties** – Connecting Transmission Owner or Interconnection Customer or both.

**Point of Interconnection** – The point where the Interconnection Facilities connect with the New York State Transmission System or the Distribution System.

**Reasonable Efforts** – With respect to an action required to be attempted or taken by a Party under this Agreement, efforts that are timely and consistent with Good Utility Practice and are otherwise substantially equivalent to those a Party would use to protect its own interests.

**Small Generating Facility** – The Interconnection Customer’s device no larger than 20 MW for the production and/or storage for later injection of electricity identified in the Interconnection Request, but shall not include the Interconnection Customer’s Interconnection Facilities.

**System Deliverability Upgrades** – The least costly configuration of commercially available components of electrical equipment that can be used, consistent with Good Utility Practice and Applicable Reliability Requirements, to make the modifications or additions to the existing New York State Transmission System that are required for the proposed project to connect reliably to the system in a manner that meets the NYISO Deliverability Interconnection Standard for Capacity Resource Interconnection Service.

**System Upgrade Facilities** – The least costly configuration of commercially available components of electrical equipment that can be used, consistent with good utility practice and Applicable Reliability Requirements to make the modifications to the existing transmission system that are required to maintain system reliability due to: (i) changes in the system, including such changes as load growth and changes in load pattern, to be addressed in the form

of generic generation or transmission projects; and (ii) proposed interconnections. In the case of proposed interconnection projects, System Upgrade Facilities are the modification or additions to the existing New York State Transmission System that are required for the proposed project to connect reliably to the system in a manner that meets the NYISO Minimum Interconnection Standard.

**Tariff** – The NYISO’s Open Access Transmission Tariff, as filed with the FERC, and as amended or supplemented from time to time, or any successor tariff.

**Upgrades** – The required additions and modifications to the Connecting Transmission Owner’s portion of the New York State Transmission System or the Distribution System at or beyond the Point of Interconnection. Upgrades may be System Upgrade Facilities or System Deliverability Upgrades Distribution Upgrades. Upgrades do not include Interconnection Facilities.

## **Attachment 2**

### **Detailed Scope of Work, Including Description and Costs of the Small Generating Facility, Interconnection Facilities, and Metering Equipment**

Equipment, including the Small Generating Facility, Interconnection Facilities, and metering equipment shall be itemized and identified as being owned by the Interconnection Customer, or the Connecting Transmission Owner. The Connecting Transmission Owner will provide a best estimate itemized cost, including overheads, of its Interconnection Facilities and metering equipment, and a best estimate itemized cost of the annual operation and maintenance expenses associated with its Interconnection Facilities and metering equipment.

#### **A. PROJECT DESCRIPTION**

Interconnection Customer is currently selling the output of its Dahowa Hydroelectric Project, a 12.265 MW (12.9 MVA) Small Generation Facility located at 190 County Route 53 in Greenwich, New York, to Connecting Transmission Owner pursuant to a Qualifying Facility power purchase agreement. Interconnection Customer plans to begin engaging in NYISO wholesale market operations for the entire output of its facility and is executing this Agreement to meet necessary engineering requirements and make facility improvements required to engage in such wholesale transactions. The electrical arrangement of this 12.265 MW facility is described in detail in Attachment 3 to this Agreement. The Point of Interconnection is switch #199 located at Connecting Transmission Owner's Cement Mountain Substation and the point of change of ownership ("POCO") is switch #188 located on a steel structure located adjacent to the Dahowa Hydroelectric Project.

#### **B. INTERCONNECTION CUSTOMER'S INTERCONNECTION FACILITIES**

Interconnection Customer's interconnection facilities includes switch #188 and the overhead circuit that continues from switch #188 onward toward Interconnection Customer's Small Generating Facility to another Interconnection Customer-owned disconnect switch #6488, which then continues overhead to an Interconnection Customer-owned riser pole. Interconnection Customer-owned underground cable continues to an indoor (metal enclosed) recloser and downstream metering cabinet. The facility has a 12.9MVA synchronous generator which provides an output voltage of 13.8kV. The generator output voltage is stepped-up through a single 10.5MVA oil filled transformer, to 34.5kV, and establishes a connection to the Connecting Transmission Owner's electric power system at this voltage. Interconnection Customer will upgrade their existing facility and interconnection equipment as described in Section D.1 of this Attachment 2.

#### **C. CONNECTING TRANSMISSION OWNER'S INTERCONNECTION FACILITIES**

Connecting Transmission Owner's Interconnection Facilities consist of a Remote Terminal Unit ("RTU") to be installed and all facilities and all equipment, including metering, owned, controlled or operated by the Connecting Transmission Owner from the POCO to the Point of Interconnection, including any modifications, additions or upgrades to such facilities

and equipment. Connecting Transmission Owner's interconnection facilities are sole use facilities and shall not include other Upgrades.

## **D. SCOPE OF WORK AND RESPONSIBILITIES**

### **1. Interconnection Customer's Scope of Work and Responsibilities**

The Interconnection Customer's Interconnection Facilities described in this Section D.1 shall be designed, constructed, operated and maintained by the Interconnection Customer in accordance with industry standards and specifications and the Connecting Transmission Owner's ("CTO") Electric System Bulletins ("ESBs") which are available at:

[https://www9.nationalgridus.com/niagaramohawk/construction/3\\_elec\\_specs.asp](https://www9.nationalgridus.com/niagaramohawk/construction/3_elec_specs.asp)

The Interconnection Customer shall submit all engineering design and electrical specifications associated with the Interconnection Customer Interconnection Facilities and any modifications to the Small Generating Facility, to the CTO for review and written acceptance in accordance with the ESBs.

Interconnection Customer shall coordinate activities with the Connecting Transmission Owner to ensure the Connecting Transmission Owner may proceed with the requested reviews, testing and approvals. These activities and requirements may include, but may not be limited to, up-front costs, performance agreements, rights of way, and site suitability prior to any potential relocation of Connecting Transmission Owner's existing facilities and installation of new facilities, as necessary.

Interconnection Customer will submit a full set of technical submittals as outlined by ESB 751, as modified by Exhibit E of the "National Grid Electric Service Plan – Dahowa Hydro 34.5 kV Substation Upgrade, dated May 1, 2019.", included herewith as Attachment 8. In addition to these technical submittals, the Project will need to comply with the following specific measures:

#### **Recloser:**

The new proposed recloser shall be installed by Interconnection Customer as soon as practical to allow the facility to operate with proper service equipment (means of disconnection and overcurrent protection). Therefore, this installation may occur prior to final approvals of the remainder of the technical submittals and equipment installations.

The new recloser shall be equipped with capacitive voltage sensing in its primary 34.5kV termination bushings. These sensors shall be configured to provide 3Vo protection, through a relay, PLC, or similar, and shall be demonstrated on the Functional Electrical Drawings (single line, three line, and breaker controls drawings) as described in ESB 751. Although the facility appears to have a robust 3Vo scheme with voltage sensing on the generator-side of the recloser, the proposed functionality (capacitive voltage sensing in recloser 34.5kV bushings) will provide line to ground detection during periods when the recloser is "open". This detection of a line to ground condition when the recloser is in the open position will result in the lock-out of the recloser.

When the recloser is “closed” and operating in normal conditions, the existing 3Vo system may be employed to detect line to ground conditions. The capacitive voltage sensors shall be configured as a redundant 3Vo scheme under this condition. This arrangement shall be clearly described within the control drawings required by ESB 751.

Manufacturer’s drawings, including schematic circuit drawings, nameplate ratings and physical data shall be provided for the Company’s review.

**Arresters:**

The 34.5kV side arresters were previously reviewed by Connecting Transmission Owner during the review of the newly proposed recloser. The Connecting Transmission Owner-accepted 36kV/27kV MCOV station class arresters will be installed by Interconnection Customer within the recloser cabinet and must be reflected in the functional electrical drawings as required by ESB 751.

**13.8kV Generator Paralleling Breaker:**

The existing 13.8kV breaker shall be fully developed and documented through the required Functional Electrical Drawings as required by ESB 751, and shall be installed by the Interconnection Customer. This includes a full DC control schematic in addition to fully developed single line and three line drawings for the Connecting Transmission Owner’s review.

**Battery System:**

The newly proposed recloser shall be equipped by Interconnection Customer with integral, manufacturer-provided batteries for open and closing energy. However, the remainder of the battery support throughout the entire electrical generation and relaying systems throughout the plant shall be provided in detail, along with alarm drawings and an explanation of the various alarms and the conditions by which they alarm.

Relay power and tripping power is required to be from a DC source. The AC source for battery power is typically required to be powered from a source located on the utility side of the customer high side three phase interrupting device. The design of the facility is to be such that it incorporates fail safe provisions to provide for tripping the generation from the EPS for loss or degradation of DC to protective relays, loss of protective relay power supplies, and loss or degradation of tripping power to the required interrupting devices. A review of the single line diagram does show multiple sources to the AC power panels including a backup generator. The one-line diagram does not show the source of the battery charging circuit. The one-line diagram does not show that a fail-safe design is being provided. These features shall be clearly demonstrated on the future Stage B technical submittals to be provided to the Connecting Transmission Owner.

Battery system maintenance records shall be provided to the Connecting Transmission Owner for their review. Where no such recent maintenance records exists, the battery system shall be tested and certified by a qualified third party contractor. Battery chargers shall also be reviewed and confirmed for adequacy and suitability to the existing battery supply system.

### **Utility Reconnect Relay:**

A utility reconnect relay which detects adequate voltage and ungrounded line conditions shall allow the Interconnection Customer to interconnect with the Connecting Transmission Owner's EPS after a minimum five (5) minute duration, post-event. The parameters of the voltage and frequency windows shall be as prescribed by IEEE 1547 Section 4.2.6. This relay shall be connected through voltage sensing devices (or potential transformers, if deemed necessary) on the high-side of the newly proposed recloser.

### **Specific Relay Settings and Adjustments:**

Refer to the "Protection Review for Dahowa Hydro" dated 12/23/16 for specific relay adjustments required to meet the Connecting Transmission Owner's approvals. Relay settings and adjustments shall be done in accordance with ESB 756 or reasonably adjusted as directed by Connecting Transmission Owner.

### **Ground Grid Testing:**

The Interconnection Customer shall substantiate the viability of their existing ground grid to attenuate step and touch potentials near the area of the main disconnects, recloser, and metering cabinet. The existing ground grid shall be tested by a qualified testing agency, and the results of the test, including ground grid resistances (at various locations mentioned above), step and touch potential thresholds, and actual step and touch potential determinations.

If the ground grid(s) cannot attenuate step and touch potentials below those prescribed by IEEE 80, an expanded ground grid design shall be presented to the Connecting Transmission Owner for their review. An acceptable ground grid design consists of a report which shows the various parameters and calculation methods involved in the design, and a design sheet showing the grid geometry, grounding rods bonding locations, and limits of the ground grid, at a minimum.

### **Heaters:**

Switchgear and enclosure heaters are a critical component in the long term viability of the Connecting Transmission Owner's instrument metering transformers and main service equipment, when installed within a metal enclosed cabinet and exposed to outdoor conditions. The Interconnection Customer will show, schematically, the wiring scheme proposed to maintain service to the enclosure heaters and shall also provide a method of testing the heaters on a regular basis. This may be through an external terminal strip which can be probed for current flow, or by an alarm scheme.

### **T1 Communication Line**

The Interconnection Customer is required to install a T1 communication line for the RTU and shall be responsible for all costs associated with such installation. Once installed, the T1 Line will become the permanent means of communication for the RTU.

## **2. Connecting Transmission Owner's Scope of Work and Responsibilities**

Connecting Transmission Owner shall pursue the necessary rights of way for the legal installation of its facilities. A RTU and associated temporary RTU communication equipment may be required for this installation and such installation shall be done by Connecting Transmission Owner. Connecting Transmission Owner endeavors to monitor current, voltage

and status of critical interconnection devices, remotely, from the Connecting Transmissions 's Eastern Regional Control Center. The RTU will be provided by the Connecting Transmission Owner. The unit will be delivered and mounted in a mutually acceptable location as determined by the Parties. Interconnection Customer is required to provide the necessary connections to the Interconnection Customer owned equipment of interest to the Connecting Transmission Owner. Given the anticipated delay in receiving a T1 communications line from Verizon, Interconnection Customer and Connecting Transmission Owner have agreed to pursue a radio-based communication scheme as an interim and temporary solution. The Interconnection Customer shall pay the Connecting Transmission Owner the fully loaded cost of the RTU and any necessary temporary RTU communication equipment, including installation, wiring and commissioning, as provided herein. Connecting Transmission Owner shall send a letter to NYISO in the form contained in Attachment 10 prior to Interconnection Customer commencing wholesale market operations.

### **3. Site Access**

Consistent with the Articles 2.3.2, 7.3, and 8 of this Agreement, NYISO and Connecting Transmission Owner shall be provided access to Interconnection Customer's premises in a manner which reasonably, consistent with Good Utility Practice, meets the needs of the party needing access but shall be provided in a manner so as not to unreasonably interfere with the ongoing business operations, rights, and obligations of Interconnection Customer. Except in an emergency situation, however, unless an alternative means of access is provided, the Parties agree not to temporarily restrict a Party's right hereunder to the other Party's facilities, property or equipment without prior written notice.

### **4. Interconnection Customer Option to Build**

If the date designated for RTU installation in Attachment 4 of this Agreement is not met by Connecting Transmission Owner, Interconnection Customer shall have the option to assume responsibility for the installation of the RTU. Except for the RTU, Interconnection Customer shall have no right to construct any other Connecting Transmission Owner facilities under this option.

If Interconnection Customer assumes responsibility for the installation of the RTU by providing five (5) days written notice to Connecting Transmission Owner,

(1) Interconnection Customer shall engineer, procure equipment, and construct the RTU (or portions thereof) using Good Utility Practice and using standards and specifications provided in advance by Connecting Transmission Owner attached hereto as Attachment 11

(2) Interconnection Customer's engineering, procurement and construction of the RTU shall comply with all requirements of law to which Connecting Transmission Owner would be subject in the engineering, procurement or construction of the RTU;

(3) Connecting Transmission Owner shall review and approve the engineering design, equipment acceptance tests, and the construction of Connecting Transmission Owner's RTU;



- (4) Prior to commencement of construction, Interconnection Customer shall provide to Connecting Transmission Owner a schedule for construction of Connecting Transmission Owner's RTU, and shall promptly respond to requests for information from Connecting Transmission Owner;
- (5) Consistent with Section D.3 of this Attachment, at any time during construction, Connecting Transmission Owner shall have the right to gain unrestricted access to Connecting Transmission Owner's RTU and to conduct inspections of the same;
- (6) At any time during construction, should any phase of the engineering, equipment procurement, or construction of Connecting Transmission Owner's RTU not meet the standards and specifications provided by Connecting Transmission Owner, Interconnection Customer shall be obligated to remedy deficiencies in that portion of Connecting Transmission Owner's RTU;
- (7) Interconnection Customer shall indemnify Connecting Transmission Owner for claims arising from Interconnection Customer's construction of Connecting Transmission Owner's RTU under the terms and procedures applicable to Article 7.3 Indemnity;
- (8) Interconnection Customer shall transfer control of Connecting Transmission Owner's RTU to Transmission Provider upon completion of construction;
- (9) Unless Parties otherwise agree, Interconnection Customer shall transfer ownership of the RTU to Connecting Transmission Owner by executing a Bill of Sale in a form acceptable to Connecting Transmission Owner, in its sole discretion;
- (10) Connecting Transmission Owner shall approve and accept for operation and maintenance the RTU to the extent engineered, procured, and constructed in accordance with this Attachment 2, Section D.4 and Attachment 11; and
- (11) Interconnection Customer shall deliver to Connecting Transmission Owner "as-built" drawings, information, and any other documents that are reasonably required by Connecting Transmission Owner to assure that the RTU is built to the standards and specifications required by Connecting Transmission Owner.

**E. ESTIMATED COSTS OF INTERCONNECTION FACILITIES**

<b>Description</b>	<b>Estimated Cost</b>
<b>Review of Stage B Submittals</b>	<b>\$33,000.00</b>
<b>RTU</b>	<b>\$65,000.00</b>
<b>Temporary RTU Radio Communication (at option of Interconnection Customer)</b>	<b>\$30,000.00</b>
<b>Testing and Commissioning-Relay/Protection</b>	<b>\$3,200.00</b>
<b>Company’s walkthrough of installation</b>	<b>\$2,200</b>
<b>Estimated Project Total Costs owed to Connecting Transmission Owner</b>	<b>\$133,400.00</b>

**F. O&M EXPENSES FOR INTERCONNECTION FACILITIES**

In accordance with Article 4.1 of this Agreement, the Interconnection Customer shall be responsible for all reasonable expenses associated with the operation, maintenance, repair and replacement of the Connecting Transmission Owner’s Interconnection Facilities, as such facilities are detailed in this Attachment 2 (“O&M Expenses”).

The Interconnection Customer shall have the option to pay such O&M Expenses either under the procedure described in Option 1 or in Option 2 below by providing written notice to Connecting Transmission Owner.

Option 1: Fixed On-Going Charge Payment:

The Connecting Transmission Owner will invoice and Interconnection Customer shall pay an annual payment to the Connecting Transmission Owner equal to the product of the Gross Plant Investment associated with the Connecting Transmission Owner Interconnection Facility and the Annual Transmission Ongoing Charge Factor, for the term of this Interconnection Agreement.

All payments due to be made by the Interconnection Customer shall be made within thirty (30) days after receiving an invoice from the Connecting Transmission Owner.

The Project's Gross Connecting Transmission Owner's Interconnection Facilities Plant Investment cost shall be established in writing by the Connecting Transmission Owner no later than 90 days following commercial operation.

The Annual Transmission On-Going Charge Factor shall be calculated annually each July based on the Connecting Transmission Owner's most recent FERC Form 1 data and will equal the sum of the Revenue Requirement Components as identified in O&M Attachment 1 divided by the Total Gross Plant of the Connecting Transmission Owner. Total Gross Plant shall equal the sum of Item Nos. A (1)(a)(b)(c) in O&M Attachment 1.

Option 2: Annual Actual O&M Expenses:

The Interconnection Customer shall pay for all actual O&M Expenses incurred by the Connecting Transmission Owner, which expenses shall be billed by the Connecting Transmission Owner quarterly as accumulated during the quarter for which they were incurred.

All payments due to be made by the Interconnection Customer shall be made within thirty (30) days after receiving an invoice from the Connecting Transmission Owner, which invoice shall be issued after the end of each quarter for the most recent quarter.

Selection by Interconnection Customer:

The Interconnection Customer shall select which option for paying such O&M Expenses by providing written notice to the Connecting Transmission Owner within thirty (30) days after the Gross Connecting Transmission Owner's Interconnection Facilities Plant Investment cost and the most recent Annual Transmission Ongoing Charge Factor have been provided to the Interconnection Customer. If the Interconnection Customer fails to provide timely notice to the Connecting Transmission Owner of the option selected, the Interconnection Customer will be deemed to have selected Option 2: Annual Actual O&M Expenses.

## **O&M ATTACHMENT 1**

Capitalized terms used in this calculation will have the following definitions:

### **Allocation Factor**

- (1) General Plant Allocation Factor shall equal Electric General Plant divided by the sum of Electric General Plant plus gas general plant as reported in the Annual Report filed with the New York State Public Service Commission.
- (2) Gross Transmission Plant Allocation Factor shall equal the total investment in Transmission Plant in Service divided by the sum of the total Transmission Plant in Service plus the total Distribution Plant in Service, excluding Intangible Plant, General Plant and Common Plant.
- (3) Transmission Wages and Salaries Allocation Factor shall equal the ratio of Connecting Transmission Owner Transmission-related direct electric wages and salaries including any direct wages or salaries charged to Connecting Transmission Owner by a National Grid Affiliate to Connecting Transmission Owner's total electric direct wages and salaries including any wages charged to Connecting Transmission Owner by a National Grid Affiliate excluding any electric administrative and general wages and salaries.

### **Ratebase and Expense Items**

- (1) Administrative and General Expense shall equal electric expenses as recorded in FERC Account Nos. 920-935.
- (2) Amortization of Investment Tax Credits shall equal electric credits as recorded in FERC Account No. 411.4.
- (3) Distribution Plant in Service shall equal the gross plant balance as recorded in FERC Account Nos. 360 – 374.
- (4) Electric Common Plant shall equal the balance of Common Plant recorded in FERC Account Nos. 389-399 multiplied by the General Plant Allocation Factor.
- (5) General Plant shall equal electric gross general plant balance recorded in FERC Account Nos. 389-399.
- (6) Materials and Supplies shall equal electric materials and supplies balance as recorded in FERC Account No. 154.
- (7) Payroll Taxes shall equal those electric payroll tax expenses as recorded in FERC Account Nos. 408.100, 408.110 and 408.130.
- (8) Prepayments shall equal electric prepayment balance as recorded in FERC Account No. 165.

(9) Real Estate Tax Expenses shall equal electric transmission-related real estate tax expense as recorded in FERC Account No. 408.140 and 408.180.

(10) Transmission Operation and Maintenance Expense shall equal electric expenses as recorded in FERC Account Nos. 560, 562-573.

(11) Transmission Plant in Service shall equal the gross plant balance as recorded in FERC Account Nos. 350-359.

(12) Transmission Revenue Credits shall equal the revenue reported in Account 456.

(13) Transmission Related Bad Debt Expense shall equal Bad Debt Expense as reported in Account 904 related to transmission billing.

(14) Wholesale Metering Cost shall equal any costs associated with any Revenue or Remote Terminal Unit (RTU) meters and associated equipment located at an internal or external tie at voltages equal to or greater than 23V. The cost shall be determined by multiplying the number of wholesale meters in FERC Account No. 370.3 by the average cost of the meters plus the average costs of installation.

In the event that the above-referenced FERC accounts are renumbered, renamed, or otherwise modified, the above sections shall be deemed amended to incorporate such renumbered, renamed, modified or additional accounts.

### **Revenue Requirement Components**

The Revenue Requirement Components shall be the sum of Connecting Transmission Owner's (A) Return and Associated Income Taxes, (B) Transmission Related Real Estate Tax Expense, (C) Transmission Related Amortization of Investment Tax Credits, (D) Transmission Related Payroll Tax Expense (E) Transmission Operation and Maintenance Expense, (F) Transmission Related Administrative and General Expenses, less (G) Revenue Credits, plus (H) Bad Debt Expense.

A. Return and Associated Income Taxes shall equal the product of the Transmission Investment Base as identified in A(1) below and the Cost of Capital Rate.

1. Transmission Investment Base shall be defined as:

Transmission Related General Plant plus Transmission Related Common Plant plus Transmission Related Regulatory Assets plus Transmission Related Prepayments plus Transmission Related Materials and Supplies plus Transmission Related Cash Working Capital.

(a) Transmission Plant in Service shall equal the balance of Total investment in Transmission Plant plus Wholesale Metering Cost.

- (b) Transmission Related General Plant shall equal the balance of investment in General Plant multiplied by the Transmission Wages and Salaries Allocation Factor.
- (c) Transmission Related Common Plant shall equal Electric Common Plant multiplied by the Gross Transmission Plant Allocation Factor and multiplied by the Transmission Wages and Salaries Allocation Factor.
- (d) Transmission Related Regulatory Assets shall equal balances in FERC Account Nos. 182.3 and 254 for state and federal regulatory assets and liabilities related to FAS109, and excess AFUDC multiplied by the Gross Transmission Plant Allocation Factor.
- (e) Transmission Related Prepayments shall equal the electric balance of Prepayments multiplied by the Gross Transmission Plant Allocation Factor.
- (f) Transmission Related Materials and Supplies shall equal the balance of Materials and Supplies assigned to Transmission added to the remainder of Material and Supplies not directly assigned to either Transmission or Distribution multiplied by the Gross Transmission Plant Allocation Factor.
- (g) Transmission Related Cash Working Capital shall be a 12.5% allowance (45 days/360 days) of the Transmission Operation and Maintenance Expense (less FERC Account 565: Transmission of Electricity by Others) and Transmission-Related Administrative and General Expense.

2. Cost of Capital Rate

The Cost of Capital Rate shall equal the proposed Weighted Costs of Capital plus Federal Income Taxes and State Income Taxes.

- (a) The Weighted Costs of Capital will be calculated for the Transmission Investment Base using Connecting Transmission Owner's actual capital structure and will equal the sum of (i), (ii), and (iii) below:
  - (i) the long-term debt component, which equals the product of the actual weighted average embedded cost to maturity of Connecting Transmission Owner's long-term debt then outstanding and the actual long-term debt capitalization ratio;
  - (ii) the preferred stock component, which equals the product of the actual weighted average embedded cost to maturity of Connecting Transmission Owner's preferred stock then

outstanding and the actual preferred stock capitalization ratio;  
and

(iii) the return on equity component, shall be the product of the allowed ROE of 11.9% plus a 50 basis point adder (per FERC Order 697 and 697A) and Connecting Transmission Owner's actual common equity capitalization ratio.

(b) Federal Income Tax shall equal

$$\frac{A \times \text{Federal Income Tax Rate}}{(1 - \text{Federal Income Tax Rate})}$$

Where A is the sum of the preferred stock component and the return on equity component, each as determined in Sections 2.(a)(ii) and for the ROE set forth in 2.(a)(iii) above

(c) State Income Tax shall equal

$$\frac{(A + \text{Federal Income Tax}) \times \text{State Income Tax Rate}}{(1 - \text{State Income Tax Rate})}$$

Where A is the sum of the preferred stock component and the return on equity component as determined in A.2.(a)(ii) and A.2.(a)(iii) above and Federal income Tax is determined in 2.(b) above.

B. Transmission Related Real Estate Tax Expense shall equal the Real Estate Tax Expenses multiplied by the Gross Plant Allocation Factor.

C. Transmission Related Amortization of Investment Tax Credits shall equal the electric Amortization of Investment Tax Credits multiplied by the Gross Transmission Plant Allocation Factor.

D. Transmission Related Payroll Tax Expense shall equal Payroll Taxes multiplied by the Transmission Wages and Salaries Allocation Factor.

E. Transmission Operation and Maintenance Expense shall equal the Transmission Operation and Maintenance Expense as previously defined.

F. Transmission Related Administrative and General Expenses shall equal the sum of the electric Administrative and General Expenses multiplied by the Transmission Wages and Salaries Allocation Factor.

G. Revenue Credits shall equal all Transmission revenue recorded in FERC account 456.

H. Transmission Related Bad Debt Expense shall equal Transmission Related Bad Debt Expense as previously defined.

**Attachment 3**

**One-line Diagram Depicting the Small Generating Facility, Interconnection Facilities,  
Metering Equipment, and Upgrades**



STEVENS & THOMPSON -  
CEMENT MT #1

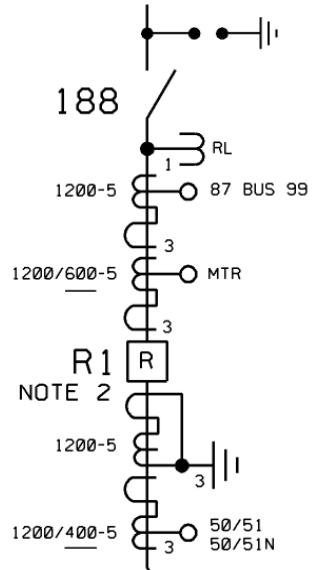

199 34.5 KV  
99

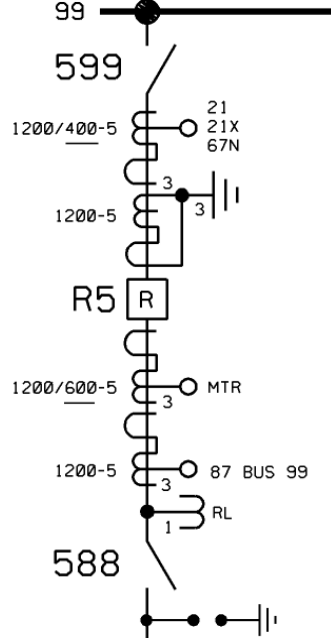

588  
BATTENKILL -  
CEMENT MT #5

ADIRONDACK HYDRO -  
CEMENT MT #7

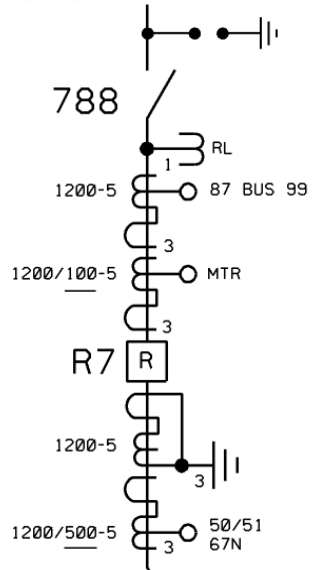

799

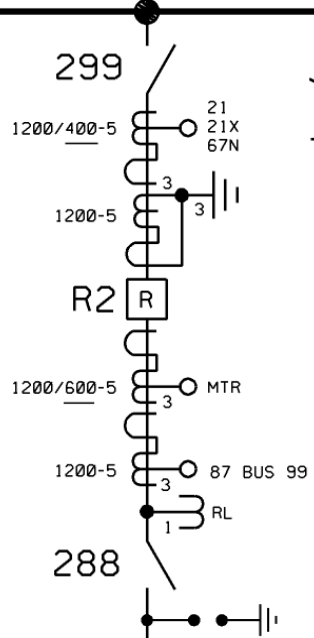

288  
CEMENT MT -  
CAMBRIDGE #2

NOTES:

1. THIS DIAGRAM IS NOT TO BE USED AS A LOCATION GUIDE WHEN GOING TO WORK ON CIRCUITS OR EQUIPMENT.
2. R1 TRANSFER TRIP - TRIPS R24 AT DAHOWA HYDRO.

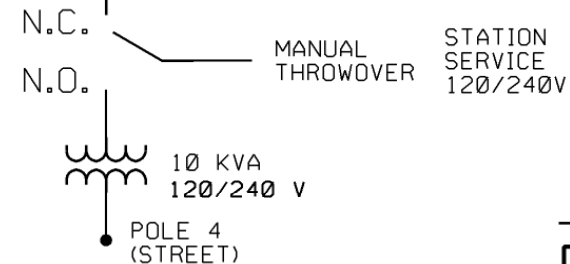
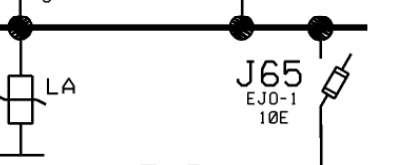
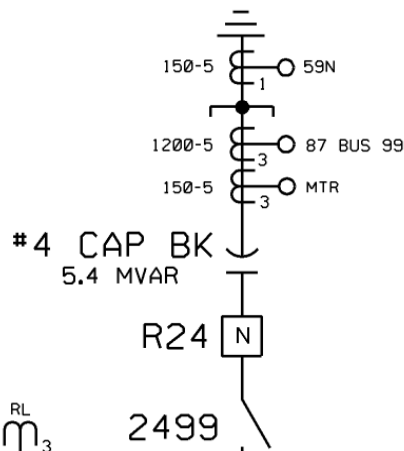

692-9837

→ This drawing supersedes B-28217-E

PREPARED BY  
**nationalgrid**  
NMPC CEMENT MOUNTAIN SUBSTATION  
OPERATING DIAGRAM

MK	DATE	BY	MF	DESCRIPTION OF REVISION AND M.O.	CK.	APP.	APPROVED	APPROVED	SCALE
1	10/14	JAP		REPLACED BORDER	RMA	BdR	DES. JAS	DR.	CK. DATE 2-2-98
0	3/08	DE		RENAMED STATION OPERATING DIAGRAM		AD	APPROVED WEL	APPROVED	INDEX 7.3-C5-E0
							APPROVED	APPROVED	NO.

CONFIDENTIALITY STATEMENT  
 This document contains confidential and proprietary information of Niagara Mohawk Power Corporation, d/b/a National Grid ("National Grid"). It is to be used by authorized contractors for National Grid solely in connection with the specific project for which it has been transmitted. Any other use, its transmission to third parties, or its reproduction without prior express written authorization of National Grid is strictly prohibited.

## Attachment 4

### Milestones

Milestone/Date		Responsible Party	
Task	Milestone	Date	Responsible Party
1.	RTU Installed	Not later than 12/30/19	CTO
1.a.	CTO Review of Interconnection Customer (IC) RTU Installation (if IC Option to Build exercised)	Within fifteen (15) days after RTU Installation	CTO
2.	Completion of Interconnection Customer Scope of Work & Responsibilities	Not later than 12/30/19	IC
3.	CTO Review of Interconnection Customer's Compliance with Interconnection Customer Scope of Work & Responsibilities	Not later than 1/17/20	CTO
4.	RTU Communication Installed, Tested and Commissioned	Not later than 1/17/20	CTO
5.	Execution of RTU Bill of Sale (if IC Option to Build exercised)	within ten (10) business days of the completion of Task 4	CTO/IC
6.	Transmit Attachment 10 Letter to NYISO	within one (1) business day of the completion of Task 4	CTO or IC
7.	Commencement of Energy Sales into the NYISO Wholesale Market.	within forty (40) business days of the completion of Task 4	IC
8.	Commencement of Cost Reconciliation Procedures	within ten (10) business days of the completion of Task 4	CTO/IC

## **Attachment 5**

### **Additional Operating Requirements for the New York State Transmission System, the Distribution System and Affected Systems Needed to Support the Interconnection Customer's Needs**

The NYISO, in consultation with the Connecting Transmission Owner, shall also provide requirements that must be met by the Interconnection Customer prior to initiating parallel operation with the New York State Transmission System or the Distribution System.

The Interconnection Customer must comply with all applicable NYISO tariffs and procedures, as amended from time to time. The Interconnection Customer must also comply with the Connecting Transmission Owner's operating instructions and requirements as referenced in Sections 1.5 and 1.6 of this Agreement, which requirements shall include equipment outages and control arrangements, tagging agreements and procedures, maintenance arrangements and responsibilities, company contacts and phone numbers and supervisory equipment.

The Interconnection Customer must comply with relevant provisions of the Connecting Transmission Owner's Electric System Bulletins, including appendices, as amended from time to time, to the extent not inconsistent with the terms of this Agreement or the NYISO OATT.

## Attachment 6

### Connecting Transmission Owner's Description of its Upgrades and Best Estimate of Upgrade Costs

The Connecting Transmission Owner shall describe Upgrades and provide an itemized best estimate of the cost, including overheads, of the Upgrades and annual operation and maintenance expenses associated with such Upgrades. The Connecting Transmission Owner shall functionalize Upgrade costs and annual expenses as either transmission or distribution related.

The cost estimate for System Upgrade Facilities and System Deliverability Upgrades shall be taken from the NYISO OATT Attachment S cost allocation process or applicable Interconnection Study, as required by Section 32.3.5.3.2 of Attachment Z. The cost estimate for Distribution Upgrades shall include the costs of Distribution Upgrades that are reasonably allocable to the Interconnection Customer at the time the estimate is made, and the costs of any Distribution Upgrades not yet constructed that were assumed in the Interconnection Studies for the Interconnection Customer but are, at the time of the estimate, an obligation of an entity other than the Interconnection Customer.

The cost estimates for Distribution Upgrades and System Upgrade Facilities and System Deliverability Upgrades are estimates. The Interconnection Customer is ultimately responsible for the actual cost of the Distribution Upgrades and System Upgrade Facilities and System Deliverability Upgrades needed for its Small Generating Facility, as that is determined under Attachments S and X and Z of the NYISO OATT.

#### A. DISTRIBUTION UPGRADES

None.

#### B. SYSTEM UPGRADE FACILITIES ("SUF") – STAND ALONE SUFs

None.

#### C. SYSTEM UPGRADE FACILITIES – OTHER SUFs

None.

## **Attachment 7**

### **Insurance Coverage**

Interconnection Customer shall, at its own expense, maintain in force throughout the period of this Agreement, the following minimum insurance coverage, with insurers authorized to do business in the State of New York:

Commercial General Liability Insurance including, but not limited to, bodily injury, property damage, products/completed operations, contractual and personal injury liability with a combined single limit of \$1 million per occurrence, \$2 million annual aggregate.

**Attachment 8**

**ESB 751 Submittal Requirements**

- ACCEPTED BY NG
- RECEIVED AND UNDER REVIEW BY NG
- REJECTED OR RETURNED TO CUSTOMER BY NG
- NOT REQUIRED FOR THIS PROJECT

PROJECT TYPE



## APPENDIX A

### REQUIRED SUBMITTALS BASED ON PROJECT TYPE AND DELIVERY VOLTAGE

TYPE OF SERVICE	SUBSTATION-SERVICE ABOVE 15KV	PRIMARY METERED SERVICE TO METER POLE 600V-15KV	PRIMARY METERED SERVICE TO SWITCHGEAR 600V-15KV	PARALLEL GENERATOR-SERVICE FROM 600V TO 15KV	PARALLEL GENERATOR-SERVICE ABOVE 15KV	NOTES
<b>REFERENCE ESB 750 SUPPLEMENTAL BULLETINS</b>	ESB 752	ESB753	ESB758, 759B	ESB 753,758,756, 759B	ESB 752,756	
COMPLETE FUNCTIONAL ELECTRICAL SINGLE LINE	X	X	X	X	X	
SITE PLANS	X	X	X	X	X	
ELECTRICAL ASSEMBLY <span style="color: red;">RECLOSER ASS'Y</span>	X	X	X	X	X	
PROFILE DRAWINGS <span style="color: red;">RECLOSER ASS'Y</span>	X	X	X	X	X	
<del>SUBSTATION LIGHTNING PROTECTION PLANS</del>	X				X	1
PROTECTIVE DEVICE COORDINATION STUDY	X	X	X	X	X	
AC ELEMENTARY (THREE LINE) DRAWINGS	X	X	X	X	X	
DC ELEMENTARY DRAWINGS	X	X	X	X	X	2
<span style="color: red;">STRUCTURAL DETAILS</span>	X				X	3
GROUND GRID ANALYSIS	X				X	
METER, CONTROL CABLE AND POWER CONDUIT DRAWINGS	X		X	X	X	
CONTROL HOUSE LAYOUT	X				X	4
RELAY PANEL DRAWINGS	X		X	X	X	
DETAILED MANUFACTURER'S CUT SHEETS	X	X	X	X	X	
TELECOMMUNICATIONS	X			X	X	5
MAINTENANCE PLAN	X	X	X	X	X	
SEQUENCE OF OPERATIONS	X			X	X	5
TESTING AND COMMISSIONING PLAN	X		X	X	X	5
ENERGIZATION PLAN	X			X	X	5

**NOTES:**

**GENERAL: ANY ADDITIONAL SUBMITTALS MAY BE REQUIRED BY THE COMPANY AS NECESSARY. THIS MATRIX PROVIDES ONLY GENERAL GUIDANCE BASED ON TYPICAL PROJECTS.**

1. ONLY REQUIRED FOR OPEN AIR INSTALLATIONS WHERE CONDUCTORS OR TERMINATIONS ARE DIRECTLY EXPOSED TO LIGHTNING STRIKES
2. IF MAIN AND SECONDARY PROTECTIVE DEVICES ARE FUSES, THERE IS NO NEED FOR DC ELEMENTARY DRAWINGS. IF EITHER MAIN OR SECONDARY PROTECTIVE DEVICE IS A CIRCUIT BREAKER, OR IF THE GENERATOR PROTECTION INCLUDES A CIRCUIT BREAKER, A DC ELEMENTARY DRAWING(S) IS REQUIRED.
3. UNLESS OTHERWISE REQUESTED BY THE COMPANY AT THE COMPANY'S DISCRETION
4. WHERE CONTROL HOUSE IS PROVIDED
5. AS SPECIFICALLY REQUIRED BY COMPANY

EXHIBIT E

## **Attachment 9**

### **Relay Settings and Adjustments**



nationalgrid	<b>DISTRIBUTION PLANNING DOCUMENT</b> Interconnection Study	Doc. #SP.NY-20627  Page 1 of 9
	<b>Small Generating Facility-Protection Review</b>	Version 1.0 –12/23/2016
<b>Project</b>	<b>Dahowa Hydro</b> 12,265 kW Hydro-electric Generator, Greenwich, NY	

**Protection Review**  
**For**  
**Dahowa Hydro**  
**12,265 kW**  
**Hydro-electric Generator System**  
**190 County Rte. 53, Greenwich, NY 12834**

**Interconnection to National Grid**  
**Northeast Region**  
**Cement Mountain #1 Line**  
**34.5 kV**

---

"THIS DOCUMENT AND ANY ATTACHMENTS HERETO ("DOCUMENT") IS MADE AVAILABLE BY NATIONAL GRID USA UPON AND SUBJECT TO THE EXPRESS UNDERSTANDING THAT: (A) NEITHER NATIONAL GRID NOR ANY OF ITS OFFICERS, DIRECTORS, AFFILIATES, AGENTS, OR EMPLOYEES MAKES ANY WARRANTY, ASSURANCE, GUARANTY, OR REPRESENTATION WITH RESPECT TO THE CONTENTS OF THE DOCUMENT OR THE ACCURACY OR COMPLETENESS OF THE INFORMATION CONTAINED OR REFERENCED IN THE DOCUMENT, AND (B) NATIONAL GRID USA, ITS OFFICERS, DIRECTORS, AFFILIATES, AGENTS, AND EMPLOYEES SHALL NOT HAVE ANY LIABILITY OR RESPONSIBILITY FOR INACCURACIES, ERRORS, OR OMISSIONS IN, OR ANY BUSINESS OR POLICY DECISIONS MADE BY ANY DIRECT OR INDIRECT RECIPIENT IN RELIANCE ON, THIS DOCUMENT OR THE INFORMATION CONTAINED OR REFERENCED THEREIN; ALL SUCH LIABILITY IS EXPRESSLY DISCLAIMED."

---

nationalgrid	<b>DISTRIBUTION PLANNING DOCUMENT</b>	Doc. #SP.NY-20627
	<b>Interconnection Study</b>	Page 2 of 9
	<b>Small Generating Facility-Protection Review</b>	Version 1.0 –12/23/2016
<b>Project</b>	<b>Dahowa Hydro 12,265 kW Hydro-electric Generator, Greenwich, NY</b>	

## **CONCLUSIONS:**

Below is the review and requirements of the existing Dahowa hydro-electric generator facility.

### **Standards for Review:**

- ESB No. 756 Appendix A – Requirements For Parallel Generation Connected to National Grid Radial Facilities in New York, version 1.2 (“ESB 756”)
- ESB No. 755 Operations and Maintenance Requirements For Services Above 600 Volts, June 2003.
- IEEE Std 1547™-2003 (R2008), IEEE Standard for Interconnecting Distributed Resources with Electric Power Systems.

### **Drawings provided for review:**

- Dahowa Hydroelectric Project, Single Line Diagram, revision dated 7/12/2016

### **Documents provided for review:**

- Transformer Test Review
- Circuit Breaker Test Report
- Dahowa Gen Saturation Curve National Industries
- Dahowa Gen Vee Curve National Industries
- Dahowa Site Map
- Form G
- Protective Relay Test Report
- Transformer Test Report

### **Drawings or Documents required for review:**

- Updated three-line drawing for all equipment (high side recloser, transformer, 13.8 kV generator breaker, generators, CT's/PT's, relaying, metering, control power) showing actual equipment installed, with a NYS PE stamp.
- The DC control schematic for the 34.5 kV system pad mounted recloser shall be provided, with a NYS PE stamp
- The DC control schematic for the 13.8 KV system generator breaker shall be provided, with a NYS PE stamp.
- Control and alarm schematic for the DC battery and charger system.
- RTU configuration and point list.
- Transformer nameplate including impedances.
- Battery charging, alarm and control schematics.

nationalgrid	<b>DISTRIBUTION PLANNING DOCUMENT</b>	Doc. #SP.NY-20627
	<b>Interconnection Study</b>	Page 3 of 9
	<b>Small Generating Facility-Protection Review</b>	Version 1.0 –12/23/2016
<b>Project</b>	<b>Dahowa Hydro 12,265 kW Hydro-electric Generator, Greenwich, NY</b>	

#### **Maintenance Requirements:**

- DC Trip Scheme test document is required. EPS protective relays are required to trip the 86E lockout relay and documentation of those functional tests needs to be provided. An 86E lockout relay functional test trip to the circuit breaker is also required.
- The test report for the Basler BE1-51/27R most likely has an incorrect part number. The test for this relay is required to show the effect of the collapsing voltage on the current pickup and timing.
- A ground grid test and step and touch potential calculation is required (ESB 755 section 4.1.5).
- DC Battery maintenance records.
- Maintenance reports for the high side disconnect switch.
- Maintenance reports for the high side pad mounted recloser.
- Maintenance records and testing reports for the backup generator.

#### **Updates required to Dahowa hydro-electric generator facility equipment and/or documentation provided as part of review:**

- The Single Line Diagram is required to be submitted with a NYS PE stamp.
- The revenue meter instrument transformer labeling shall be updated to include the ratios and to indicate no fusing on the PT's.
- The description for the three phase gang operated disconnect switch shall be updated to include Utility 24/7 access.
- The description for the three phase 34.5 kV S&C SM5 fuses 200E fuses shall be updated to indicate the speed (i.e. standard, slow).
- The 39 kV arresters shall be examined to determine the suitability for this application. Typical arresters for effectively grounded designed systems for this voltage class are 27 kV class (22 kV MCOV). This size arrester would be subject to damage during ungrounded islanded operation of this facility on the Cement Mountain – Stevens and Thompson Line #1. The 39 kV class arrester is a 31.5 kV MCOV arrester. The sizing is for long term ungrounded applications (2000 hours). While the system is not designed for effective grounding, National Grid operates the system with ground fault relaying and significantly shorter clearing times. The use of this size arrester does allow for the high unfaulted phase voltages, but does not provide as good a protective margin as a 36 kV class (27 kV MCOV) arrester.
- CT accuracy class must be provided for relaying CT's.
- A utility reconnect relay must be provided at the 34.5 kV voltage level on the utility side of the high side pad mounted recloser to comply with IEEE 1547 section 4.2.6. The

nationalgrid	<b>DISTRIBUTION PLANNING DOCUMENT</b>	Doc. #SP.NY-20627
	<b>Interconnection Study</b>	Page 4 of 9
	<b>Small Generating Facility-Protection Review</b>	Version 1.0 –12/23/2016
<b>Project</b>	<b>Dahowa Hydro 12,265 kW Hydro-electric Generator, Greenwich, NY</b>	

utility restoration scheme is required to prevent the generation from being connected to the EPS until the relay has detected that the Utility EPS has been within the voltage and frequency windows identified by IEEE 1547 section 4.2.6 for a minimum of five minutes.

- The 27, 59, & 81 relaying which is presently provided by the discreet Basler relays on the one line diagram is required to be located on the 34 kV system side of the GSU transformer, on the utility side of high side recloser, in order to facilitate detection of single phase line disturbances. This shall be facilitated by three phase Wye-ground/ Wye-ground PT's. The relaying shall be set in accordance with IEEE 1547-2003.
- The existing 27 undervoltage settings, per the relay test sheets, are 107.5 VAC for 0.5 seconds and fed from the 13.8 kV generator system 14400/120 L-L PT's. There are 3 relays total. This setting equates to approximately 93% at 0.5 seconds. The undervoltage requirements are to be per IEEE 1547, connected on the 34.5 kV system and will require two distinct settings. Per the standard, the total clear will be the relay trip time plus the breaker clearing times to meet the requirements in the table below.
- The existing 59 overvoltage settings, per the relay test sheets, are 124 VAC for 0.5 seconds and fed from the 13.8 kV generator system 14400/120 L-L PT's. There are 3 relays total. This setting equates to 107% at 0.5 seconds. The overvoltage requirements are to be per IEEE 1547, connected on the 34.5 kV system and will require two distinct settings. Per the standard, the total clear will be the relay trip time plus the breaker clearing times to meet the requirements in the table below.

The voltage table from IEEE 1547 is provided below:

**Table 1—Interconnection system response to abnormal voltages**

Voltage range (% of base voltage <sup>a</sup> )	Clearing time(s) <sup>b</sup>
V < 50	0.16
50 ≤ V < 88	2.00
110 < V < 120	1.00
V ≥ 120	0.16

<sup>a</sup>Base voltages are the nominal system voltages stated in ANSI C84.1-1995, Table 1.

<sup>b</sup>DR ≤ 30 kW, maximum clearing times; DR > 30kW, default clearing times.

- The existing 81 under frequency settings, per the relay test sheets, are 59 HZ VAC for 0.5 seconds and fed from the 13.8 kV generator system 14400/120 L-L PT's. There is one relay for this function. The under frequency requirements are to be per IEEE 1547,

nationalgrid	<b>DISTRIBUTION PLANNING DOCUMENT</b>	Doc. #SP.NY-20627
	<b>Interconnection Study</b>	Page 5 of 9
	<b>Small Generating Facility-Protection Review</b>	Version 1.0 –12/23/2016
<b>Project</b>	<b>Dahowa Hydro 12,265 kW Hydro-electric Generator, Greenwich, NY</b>	

connected on the 34.5 kV system and will require two distinct settings as shown below. Per the standard, the total clear will be the relay trip time plus the breaker clearing times to meet the requirements in the table below. Be aware that the under frequency settings must comply with the NPCC Directory 12 under frequency criteria and curve.

- The existing 81 over frequency settings, per the relay test sheets, are 60.5 Hz for 0.5 seconds and fed from the 13.8 kV generator system 14400/120 L-L PT's. There is one relay for this function. The under frequency requirements are to be per IEEE 1547, connected on the 34.5 kV system and will require one distinct settings. Per the standard, the total clear will be the relay trip time plus the breaker clearing times to meet the requirements in the table below.

The frequency table from IEEE 1547 is provided below:

**Table 2—Interconnection system response to abnormal frequencies**

DR size	Frequency range (Hz)	Clearing time(s) <sup>a</sup>
≤ 30 kW	> 60.5	0.16
	< 59.3	0.16
> 30 kW	> 60.5	0.16
	< {59.8 – 57.0} (adjustable set point)	Adjustable 0.16 to 300
	< 57.0	0.16

<sup>a</sup>DR ≤ 30 kW, maximum clearing times; DR > 30 kW, default clearing times.

- The existing PT's used to feed the existing 34.5 kV system 64 (3Vo) scheme are shown as 34500/120 ratio and are shown on the customer side of the customer high side recloser. This is not a typical ratio (287.5:1) and needs to be verified. This scheme needs to be relocated to the utility side of the recloser.
- The protective relay test report document shows testing for a 59 device. The one-line diagram shows a 64 designation provided for 3Vo. Clarification is required. The setting shown for the 59 device (3Vo), assuming it is the required EPS 3Vo protective function, is acceptable with the provided 39 kV class arresters on the customer equipment and Company metering. Any arrester changes will require a review of the setting.
- The DTT scheme previously installed as part of the original installation and disconnected in 2009 is not required. Anti-islanding mitigation for this facility is not required as the line

nationalgrid	<b>DISTRIBUTION PLANNING DOCUMENT</b>	Doc. #SP.NY-20627
	<b>Interconnection Study</b>	Page 6 of 9
	<b>Small Generating Facility-Protection Review</b>	Version 1.0 –12/23/2016
<b>Project</b>	<b>Dahowa Hydro 12,265 kW Hydro-electric Generator, Greenwich, NY</b>	

is operated radially with only the hydro facility on the line. Should load customers be added to the line, DTT will most likely be required to be re-activated.

- The one-line diagram shows protective functions 50/51 and 50/51N. The relay test report provided only shows a test for the phase 51 function. The relay test report for the 51 function provides for a time dial of zero, no curve type listed (B3 curve assumed based on part number), and shows no instantaneous setting which does not match the one-line diagram. The setting at the CT ratio shown does not appear to be correct with the rating of the bank. Relay settings and a test report are required for the 50, 51, 50N and 51N functions.
- Sync check for the generator is required. This function is shown on the one-line diagram. No settings have been provided. Settings must comply with table 5 of IEEE 1547 shown below:

**Table 5—Synchronization parameter limits for synchronous interconnection to an EPS, or an energized local EPS to an energized Area EPS**

Aggregate rating of DR units (kVA)	Frequency difference ( $\Delta f$ , Hz)	Voltage difference ( $\Delta V$ , %)	Phase angle difference ( $\Delta \Phi$ , °)
0 – 500	0.3	10	20
> 500 – 1 500	0.2	5	15
> 1 500 – 10 000	0.1	3	10

- Sync check is not required for the high side pad mounted recloser as the one-line diagram shows that an open recloser automatically trips the low side 13.8 kV generator breaker. This will need to be verified against the DC breaker schematics which were not provided for this review.
- Test switches are required for all non-drawout EPS relays (27, 59, 81O/U, 51V, 64) as required by ESB 756 Appendix B including the lockout relays.
- Relay power and tripping power is required to be from a DC source. The AC source for battery power is typically required to be powered from a source located on the utility side of the customer high side three phase interrupting device. The design of the facility is to be such that it incorporates fail safe provisions to provide for tripping the generation from the EPS for loss or degradation of DC to protective relays, loss of protective relay power supplies, and loss or degradation of tripping power to the required interrupting devices. A review of the single line diagram does show multiple sources to the AC power panels including a backup generator. The one-line diagram does not show the source of the

nationalgrid	<b>DISTRIBUTION PLANNING DOCUMENT</b>	Doc. #SP.NY-20627
	<b>Interconnection Study</b>	Page 7 of 9
	<b>Small Generating Facility-Protection Review</b>	Version 1.0 –12/23/2016
<b>Project</b>	<b>Dahowa Hydro 12,265 kW Hydro-electric Generator, Greenwich, NY</b>	

battery charging circuit. The one-line diagram does not show that a fail-safe design is being provided.

- An RTU is required for this installation.
- The Form G document shows that the exciter is a Basler DECS 400 which is not indicated on the one-line diagram. Any protective functions such as voltage or frequency that may be used in this equipment must comply with IEEE 1547. The IC is advised that operating in power factor mode or voltage regulate is at the discretion of the Company. Excitation system limiters are to adhere to the requirements of the bulletin.

**System Upgrades required to National Grid EPS:**

1. None required.

**CUSTOMER REQUIREMENTS:**

The Report on Review of the Retail Customer Interconnection Application dated 12/23/2016 outlines upgrades to existing switchgear, protective relays and control systems. Prior to entering construction the DG Customer must provide a complete design package signed by licensed engineer in the state of NY including 1L, 3L, DC schematics, equipment specification sheets, protective device coordination study & proposed digital settings file, sequence of operation & test procedure(s) and records of interval testing and electrical equipment maintenance in accordance with the Company's ESB's 750, 751, 753, 755, 756, 758, IEEE 1547 and the NYS SIR for review and acceptance by National Grid.

The estimate for National Grid's labor required for review of customer documentation, field verification & commissioning is \$23,992. See Attachment A hereto for the estimate breakdown.

**Attachment 10**  
**Form of Letter to NYISO**



{National Grid Letterhead }  
{ }  
{ }  
{ }

To the NYISO Customer Registration Team,

Niagara Mohawk Power Corporation is the connecting transmission owner to which the Dahowa Hydroelectric Project (“Dahowa”), located in NYISO Zone F on the Battenkill River, is interconnected. This letter is written to confirm that Dahowa has the below communications equipment installed. Niagara Mohawk Power Corporation can confirm that the facility has both:

1. Metering and communications equipment capable of 6-second data send and receive
2. Revenue grade meter

This equipment is in place and operational.

Thank you,

{Appropriate signer from Niagara Mohawk Power Corporation}

**Attachment 11**

**RTU Standards and Specifications**

nationalgrid	<b>ENGINEERING DOCUMENT</b> Distributed Generation Specification	Page 1 of 17
	<b>SCADA Communications Requirements</b>	Version 2.0
	<b>NY- 20627 Dahowa Hydro 12,265 kW Hydro-Electric Generator, Greenwich, NY</b>	10/18/2019

**SCADA Communications**  
**Installation Requirements Document**  
**For The Dahowa Hydro-electric Generator System**  
**12,265 kW**  
**190 County Rte. 53, Greenwich, NY 12834**

PRINTED COPIES ARE NOT DOCUMENT CONTROLLED.		
File: Dahowa_Hydro_Generator 12265 Kw_Ny-20627_Scada Document_10_18_19	Originating Department: Retail Connections Eng.	Sponsor: Neil LaBrake-Jr.

nationalgrid	<b>ENGINEERING DOCUMENT</b> Distributed Generation Specification	Page 2 of 17
	<b>SCADA Communications Requirements</b>	Version 2.0
	<b>NY- 20627 Dahowa Hydro 12,265 kW Hydro-Electric Generator, Greenwich, NY</b>	10/18/2019

**TABLE OF CONTENTS**

<b><u>Section</u></b>	<b><u>Page</u></b>
<b>1. OBJECTIVE .....</b>	<b>3</b>
<b>2. GENERAL .....</b>	<b>3</b>
<b>3. DESIGN AND INSTALLATION REQUIREMENTS .....</b>	<b>3</b>
<b>4. TESTING AND COMMISSIONING .....</b>	<b>7</b>
<b>5. OPERATION AND MAINTENANCE .....</b>	<b>8</b>
<b>6. REVISION HISTORY .....</b>	<b>8</b>
Table 1 - Analog Point Assignment .....	9
Table 2 - Status Point Assignment .....	11
Table 3 - Control Point Assignment.....	11
Figure 1 – RTU Functional Diagram.....	12
Temporary proposal.....	12
Final proposal .....	13
Figure 3 - Customer to RTU Functional Diagram .....	14
Figure 4 – Interconnection Plan .....	16
Figure 5 – RTU Cabinet Layout.....	17

PRINTED COPIES ARE NOT DOCUMENT CONTROLLED.

File: Dahowa_Hydro_Generator 12265 Kw_Ny-20627_Scada Document_10_18_19	Originating Department: Retail Connections Eng.	Sponsor: Neil LaBrake-Jr.
--	--	------------------------------

nationalgrid	<b>ENGINEERING DOCUMENT</b> <b>Distributed Generation Specification</b>	Page 3 of 17
	<b>SCADA Communications Requirements</b>	Version 2.0
	<b>NY- 20627 Dahowa Hydro</b> <b>12,265 kW Hydro-Electric Generator,</b> <b>Greenwich, NY</b>	10/18/2019

## 1. OBJECTIVE

The objective of this specification is to provide the applicable standards and criteria for the design and installation of a National Grid Communication Gateway (“RTU”) at Generation facilities<sup>1</sup> (“Facilities”, or “Customer”) providing SCADA information to the Niagara Mohawk Corporation d/b/a National Grid (“National Grid” or “Company”) Energy Management System. This requirement is documented in a Company impact study that lists telecommunications requirements to the Customer’s Facility in order to provide real time data to National Grid’s Regional Control Operators.

## 2. GENERAL

To protect the integrity of the Company’s EPS, real time system configurations and load flow data is required to allow for system operators to make informed switching and operations decisions. SCADA data is required from the Customer substation imported into National Grid’s energy management system. As such; National Grid has developed standard RTU packages for various types of generation facilities. This document provides a Customer-Generator with the RTU requirements specifically associated with the Facility.

## 3. DESIGN AND INSTALLATION REQUIREMENTS

### 3.1 Communications between the RTU and the Company’s Energy Management System

The Customer shall be responsible for initiating contact with the local telephone company and ordering the required circuits in accordance with this document and the Company’s ESB 756.

The RTU equipment at the Customer’s facility shall utilize a DSO 64k/MPLS circuit. This circuit shall be connected by the local telephone company onto the National Grid VPN Network Reconfiguration Service (NRS). VPN number to be determined by National Grid at the time of ordering.

In addition to the requirements described in these specifications, the telephone company will require the Customer to complete and return the following forms: private IP extranet agreement, high voltage protection form, PIP circuit order. The Customer will need to meet with the telephone company’s outside plant engineer to coordinate the following: communications conduit paths, site plans, and equipment placement & mounting. Further details on these requirements will be provided to the Customer by the telephone company.

DPAM and the customer have agreed to a temporary solution where the NG RTU telemetry values will be sent via 900 MHz radio communication from Dahowa Hydro to Cement Mountain or Battekill substation. The Customer will be responsible to purchase, install and maintain the necessary radio equipment and find an appropriate mounting location to reliably receive this signal at Dahowa Hydro.

NG will be responsible to purchase, install and maintain the necessary radio equipment and find an appropriate mounting location to reliably receive this signal at Cement Mountain or Battekill substation. All the cost for work and materials shall be reimbursed to the company by the customer.

<sup>1</sup> A distributed generation facility interconnecting with the Company’s distribution system for parallel operation, excluding facilities transacting in the wholesale market.

PRINTED COPIES ARE NOT DOCUMENT CONTROLLED.		
File: Dahowa_Hydro_Generator 12265 Kw_Ny-20627_Scada Document_10_18_19	Originating Department: Retail Connections Eng.	Sponsor: Neil LaBrake-Jr.

nationalgrid	<b>ENGINEERING DOCUMENT</b> <b>Distributed Generation Specification</b>	Page 4 of 17
	<b>SCADA Communications Requirements</b>	Version 2.0
	<b>NY- 20627 Dahowa Hydro</b> <b>12,265 kW Hydro-Electric Generator,</b> <b>Greenwich, NY</b>	10/18/2019

### 3.2 RTU Hardware

The following equipment shall be provided by the Company:

Item	Quantity	Description	Notes
1	1	Novatech Starfish RTU	Novatech Starfish RTU. Includes: Enclosure Orion LXm
2		Misc. Cables	Internal to RTU cabinet, as needed.
3	1	GarrettCom DX940 NY-Configuration #2 24-48VDC Per GarrettcomUsing Firmware Version 3.1.6  DX940-4RJ-L With Options: DXC-4SERIAL DXC-T1E1 ACC-DX-00-RM MNS-DX-ADVAR MNS-DX-SECURE	DX940 base unit loaded with Firmware Version 3.1.6. Four RJ45 10/100 Ethernet ports in slot B. Includes 24 - 48V DC power supply, panel mounting. Two Alarm Contacts, software controlled. Wire speed filtering and forwarding across all Ethernet ports. MNS-DX software license included. Software includes IP Routing, per VLAN Routing, ICMP, ARP, Diffserv, Port Security, event logging and alarms, and more. Web-based GUI and CLI via Telnet. P/N DX940-4RJ-L P/N MNS-DX software license included  NG Protection Telecommunications Operations personnel to configure and install this unit within the RTU Cabinet.
4	1	Serial Radio	Schweitzer Engineering Laboratories; SEL-3031 Serial Radio Transceiver.  <b>Product:</b> SEL-3031 <b>Part Number:</b> 30310R41XXX <b>Frequency:</b> 900MHz Frequency <b>Mounting:</b> 19 in Rack Mount <b>Power Supply:</b> 125VDC <b>Comm. Option:</b> Three RS-232 serial ports <b>Encryption:</b> None
5	2	Yagi Directional Antenna	Marathon Yagi Antenas, 800/900 MHz Series <b>Product:</b> PCTEL Maxrad <b>Part Number:</b> BMYD8900, 14 Dbd gain Yagi antenna with connectors. <b>Frequency:</b> 890-960MHz Frequency <b>Mounting:</b> BWC1001(A) mount

PRINTED COPIES ARE NOT DOCUMENT CONTROLLED.

File: Dahowa_Hydro_Generator 12265 Kw_Ny-20627_Scada Document_10_18_19	Originating Department: Retail Connections Eng.	Sponsor: Neil LaBrake-Jr.
--	--	------------------------------

nationalgrid	<b>ENGINEERING DOCUMENT</b>		
	<b>Distributed Generation Specification</b>		Page 5 of 17
	<b>SCADA Communications Requirements</b>		Version 2.0
		<b>NY- 20627 Dahowa Hydro 12,265 kW Hydro-Electric Generator, Greenwich, NY</b>	10/18/2019

6	200 ft	Flexible coax cable	<b>Model:</b> LMR-400.  Note: with connectors as needed to connect to the radio, polyphaser, and antenna.
7	2	Lighting protection	Polyphaser  <b>Model:</b> IS-NEMP-C2 with Hardware Kit connected to earth ground
8	1	EMS Gateway  To be installed at Cement RD	GarrettCom DX940: Model #: DX940ETXH-2GTX- <b>DDS</b> -XXX-4S-SA-XX DX940 base unit with four RJ45 10/100/1000 Ethernet ports in slot B. Includes 90 – 250 V <sub>DC</sub> /V <sub>AC</sub> power supply, panel mounting. Two Alarm Contacts, software controlled. Wire speed filtering and forwarding across all Ethernet ports. MNS-DX software license included. Software includes IP Routing, per VLAN Routing, ICMP, ARP, Diffserv, Port Security, event logging and alarms, and more. Web-based GUI and CLI via Telnet. (DX940ETXH)  Two (2) 10.100.1000 Mb RJ45 Ethernet ports in Slot A (2GTX)  Four (4) Serial ports module in DX940 slot D (4S)  Contains both MNS-DX-ADVAR and MNS-DX-SECURE software, key-enabled licensed software for use on one Magnum DX or 10-series Configurable Industrial Router. (SA)  No conformal coating (XX)  P/N ACC-DX-00-RM Rack-mount brackets  <b><u>Please ship to EMS CNI NY for programming:</u></b> Ed Dumas – EMS CNI NY 7437 Henry Clay Blvd., Bldg. HCB3 Liverpool, NY.13088
9	1	Serial Radio	Schweitzer Engineering Laboratories; SEL-3031 Serial Radio Transceiver.

PRINTED COPIES ARE NOT DOCUMENT CONTROLLED.

File: Dahowa_Hydro_Generator 12265 Kw_Ny-20627_Scada Document_10_18_19	Originating Department: Retail Connections Eng.	Sponsor: Neil LaBrake-Jr.
--	--	------------------------------

nationalgrid	<b>ENGINEERING DOCUMENT</b> <b>Distributed Generation Specification</b>	Page 6 of 17
	<b>SCADA Communications Requirements</b>	Version 2.0
	<b>NY- 20627 Dahowa Hydro</b> <b>12,265 kW Hydro-Electric Generator,</b> <b>Greenwich, NY</b>	10/18/2019

			<b>Product:</b> SEL-3031 <b>Part Number:</b> 30310W01XXX <b>Frequency:</b> 900MHz Frequency <b>Mounting:</b> Wall Mount <b>Power Supply:</b> 9-30VDC <b>Comm. Option:</b> Three RS-232 serial ports <b>Encryption:</b> None
--	--	--	---

### 3.3 Customer Installation Requirements

#### 3.3.1 General

The Customer shall install all equipment associated with the RTU in accordance with all applicable codes. The installation shall be performed by qualified contractors/personnel.

All electrical and mechanical hardware required to facilitate the installation of the RTU and its associated circuits shall be provided by the Customer except where explicitly identified otherwise.

#### 3.3.2 Mounting and Location

RTU equipment mounting location(s) shall be mutually agreed upon between the Company and Customer and shall be capable of safely supporting RTU enclosure, associated components and complete installation contents.

- The RTU equipment shall be located so as to restrict access from the general public.
- RTU enclosure shall have a minimum of 4 feet wide wall space measured on center of the enclosure and 4 feet of clear working space or the clear space requirements for electrical equipment as defined in Article 110 in the NEC, whichever is greater.
- The RTU equipment shall be independent of the other Customer communications equipment and shall be accessible to Company personnel.
- All mounting hardware shall be provided by the Customer.
- Refer to Figure 4 for physical details of the RTU enclosure.

#### 3.3.3 Grounding and Bonding

- Mounting height shall be 3'-6" to bottom of cabinet from finished grade.
- The RTU cabinet shall be bonded to the customer's grounding electrode system.
- Where metallic conduits are installed, they shall have nylon insulated ground bushing at entrances. Metallic conduits shall be bonded to the Customer's local equipment grounding system in accordance with the NEC.

PRINTED COPIES ARE NOT DOCUMENT CONTROLLED.		
File: Dahowa_Hydro_Generator 12265 Kw_Ny-20627_Scada Document_10_18_19	Originating Department: Retail Connections Eng.	Sponsor: Neil LaBrake-Jr.



nationalgrid	<b>ENGINEERING DOCUMENT</b> <b>Distributed Generation Specification</b>	Page 7 of 17
	<b>SCADA Communications Requirements</b>	Version 2.0
	<b>NY- 20627 Dahowa Hydro</b> <b>12,265 kW Hydro-Electric Generator,</b> <b>Greenwich, NY</b>	10/18/2019

### 3.3.4 Circuits and Wiring

The following circuits shall be provided to the RTU by the Customer:

- One (1) 20 A, 120 VAC, 60 Hz circuit to the RTU enclosure.
- A dedicated 10A, 48VDC or 125VDC input is required to the RTU from the station battery.
- All analog or digital circuits from the respective Customer equipment to the RTU as required by Figures 1 and 2.
- Communications circuits from Customer owned equipment (meters, protective relays, etc) to the RTU shall be accomplished via an RS-232 port on the RTU. Due to the limitations of RS-232 serial communications cable, if the distance between the RTU and the Customer's respective communications device exceeds 50 circuit feet, the Customer may utilize an alternate communications medium such as RS-485 communications or fiber optic cable if the appropriate media converters are provided and the alternate communications medium is accepted by the Company.

### 3.3.5 Communications Protocol and Programming

- The communications protocol for digital circuits between the customer owned equipment to the RTU shall be DNP3.
- The port configuration and addressing of the customer's equipment shall be as specified in Figures 1 and 2.
- Binary status, control, and analog data points shall be configured in the binary/analog in/out tables of the DNP point map of the customer's device as specified in Tables 1, 2, and 3.
- Analogs shall be configured as 16-bit signed integers.

## 4. TESTING AND COMMISSIONING

- Prior to testing and commissioning the Customer is responsible for verifying installation and performing wire checks or logic testing of the Customer-owned equipment and attest to its accuracy in writing to the Company.
- The Company, with assistance from the Customer, will perform final testing and commissioning of the complete RTU installation to verify acceptable signal presence and system performance.

PRINTED COPIES ARE NOT DOCUMENT CONTROLLED.		
File: Dahowa_Hydro_Generator 12265 Kw_Ny-20627_Scada Document_10_18_19	Originating Department: Retail Connections Eng.	Sponsor: Neil LaBrake-Jr.

nationalgrid	<b>ENGINEERING DOCUMENT</b> <b>Distributed Generation Specification</b>	Page 8 of 17
	<b>SCADA Communications Requirements</b>	Version 2.0
	<b>NY- 20627 Dahowa Hydro</b> <b>12,265 kW Hydro-Electric Generator,</b> <b>Greenwich, NY</b>	10/18/2019

## 5. OPERATION AND MAINTENANCE

### 5.1 Customer Responsibilities

- In addition to the requirements of ESB 756, the Customer shall refer to Section 1.7 of the ESB 750 and to ESB 755 regarding their responsibility for their electric service operating and maintenance requirements.
- The Customer shall provide the Company safe access to allow Company personnel the ability to inspect, maintain and operate the Company's RTU equipment at the Company's discretion. Access shall include a clear safe work environment for testing and calibration and adjustment of the equipment during initial installation and commissioning.
- The Customer may only operate the Generator in parallel with the Company's EPS upon loss of RTU if permitted by the Company and after the establishment of proper administrative protocols with the Regional Control Operator.

### 5.2 Company Responsibilities

The Company is responsible for the operation and maintenance of the Company's equipment at the Customer's facility.

## 6. REVISION HISTORY

<u>Version</u>	<u>Date</u>	<u>Description of Revision</u>
1.0	07/27/2016	RTU Specifications Requirements for Customer Facility.
2.0	01/23/2017	Updated the mounting requirements in section 3.3.3, and removed the GFCI outlet requirements in section 3.3.4.

PRINTED COPIES ARE NOT DOCUMENT CONTROLLED.

File: Dahowa_Hydro_Generator 12265 Kw_Ny-20627_Scada Document_10_18_19	Originating Department: Retail Connections Eng.	Sponsor: Neil LaBrake-Jr.
--	--	------------------------------

nationalgrid	<b>ENGINEERING DOCUMENT</b> Distributed Generation Specification	Page 9 of 17
	SCADA Communications Requirements	Version 2.0
	NY- 20627 Dahowa Hydro 12,265 kW Hydro-Electric Generator, Greenwich, NY	10/18/2019

Table 1 – Analog\_IN Point Assignment

EMS Pt. No.	Description /ID	Quantity	Ports	Input Source
0	REVENUE METER LN1	MW 3ph	Orion LXm Port 3	REV_MET
1		MVAR 3ph		
2		A ph1		
3		A ph2		
4		A ph3		
5		KV ph1-n		
6		KV ph2-n		
7		KV ph3-n		
8		kV Avg (L-L)		
9	BKR R52R	A ph1	Orion LXm Port 2	SEL_RTAC Port 1
10		A ph2		
11		A ph3		
12		KV ph1-n		
13		KV ph2-n		
14		KV ph3-n		
15		MW 3ph		
16		MVAR 3ph		
17	Dahowa Hydro 6 Second Unit Desired Generation (UDG)	MW 3ph		
18	Dahowa Hydro 5 minute Basepoint	MW 3ph		

PRINTED COPIES ARE NOT DOCUMENT CONTROLLED.

File: Dahowa_Hydro_Generator 12265 Kw_Ny-20627_Scada Document_10_18_19	Originating Department: Retail Connections Eng.	Sponsor: Neil LaBrake-Jr.
--	--	------------------------------

nationalgrid	<b>ENGINEERING DOCUMENT</b> Distributed Generation Specification	Page 10 of 17
	SCADA Communications Requirements	Version 2.0
	NY- 20627 Dahowa Hydro 12,265 kW Hydro-Electric Generator, Greenwich, NY	10/18/2019

19	Net Generation	MW 3ph		
20	Dahowa Hydro Curtailment Flag (0=ON, 1=OFF)		▼	▼

Table 2 - Analog\_OUT Point Assignment

EMS Pt. No.	Description /ID	Quantity	Ports	Input Source
0	Dahowa Hydro 6 Second Unit Desired Generation (UDG)	MW 3ph	Orion LXm Port 4	SEL_RTAC Port 2
1	Dahowa Hydro 5 minute Basepoint	MW 3ph		
2	Net Generation	MW 3ph		
3	Dahowa Hydro Curtailment Flag (0=ON, 1=OFF)		▼	▼

PRINTED COPIES ARE NOT DOCUMENT CONTROLLED.

File: Dahowa_Hydro_Generator 12265 Kw_Ny- 20627_Scada Document_10_18_19	Originating Department: Retail Connections Eng.	Sponsor: Neil LaBrake-Jr.
--	--	------------------------------

nationalgrid	<b>ENGINEERING DOCUMENT</b> Distributed Generation Specification	Page 11 of 17
	SCADA Communications Requirements	Version 2.0
	NY- 20627 Dahowa Hydro 12,265 kW Hydro-Electric Generator, Greenwich, NY	10/18/2019

Table 3 - Status Point Assignment

EMS Pt. No	Description	Ports	Input Source	Device
0	69S Remote/Local		Orion LXm IN01	Orion LXm
1	UPS Alarm		Orion LXm INB1	▼
2	Radio Trouble	Orion LXm Port 1	Radio	SEL-3031
3	Dahowa_Hydro Comm Status	Orion LXm Port 2		SEL-RTAC
4	BKR R52R	Orion LXm Port 2		SEL-RTAC
5	REV_MET LN1 Comm Status	Orion LXm Port 3	REV_MET	REV_MET/LN1

Table 4 - Control Point Assignment

EMS Pt. No.	Description /ID	Polling Port	Output	Device
0	BKR R52R	Orion LXm Port 2		SEL-RTAC

PRINTED COPIES ARE NOT DOCUMENT CONTROLLED.

File: Dahowa_Hydro_Generator 12265 Kw_Ny-20627_Scada Document_10_18_19	Originating Department: Retail Connections Eng.	Sponsor: Neil LaBrake-Jr.
--	--	------------------------------

nationalgrid	<b>ENGINEERING DOCUMENT</b> Distributed Generation Specification	Page 12 of 17
	<b>SCADA Communications Requirements</b>	Version 2.0
	<b>NY- 20627 Dahowa Hydro</b> 12,265 kW Hydro-Electric Generator, Greenwich, NY	10/18/2019

Figure 1 – RTU Functional Diagram  
Temporary proposal

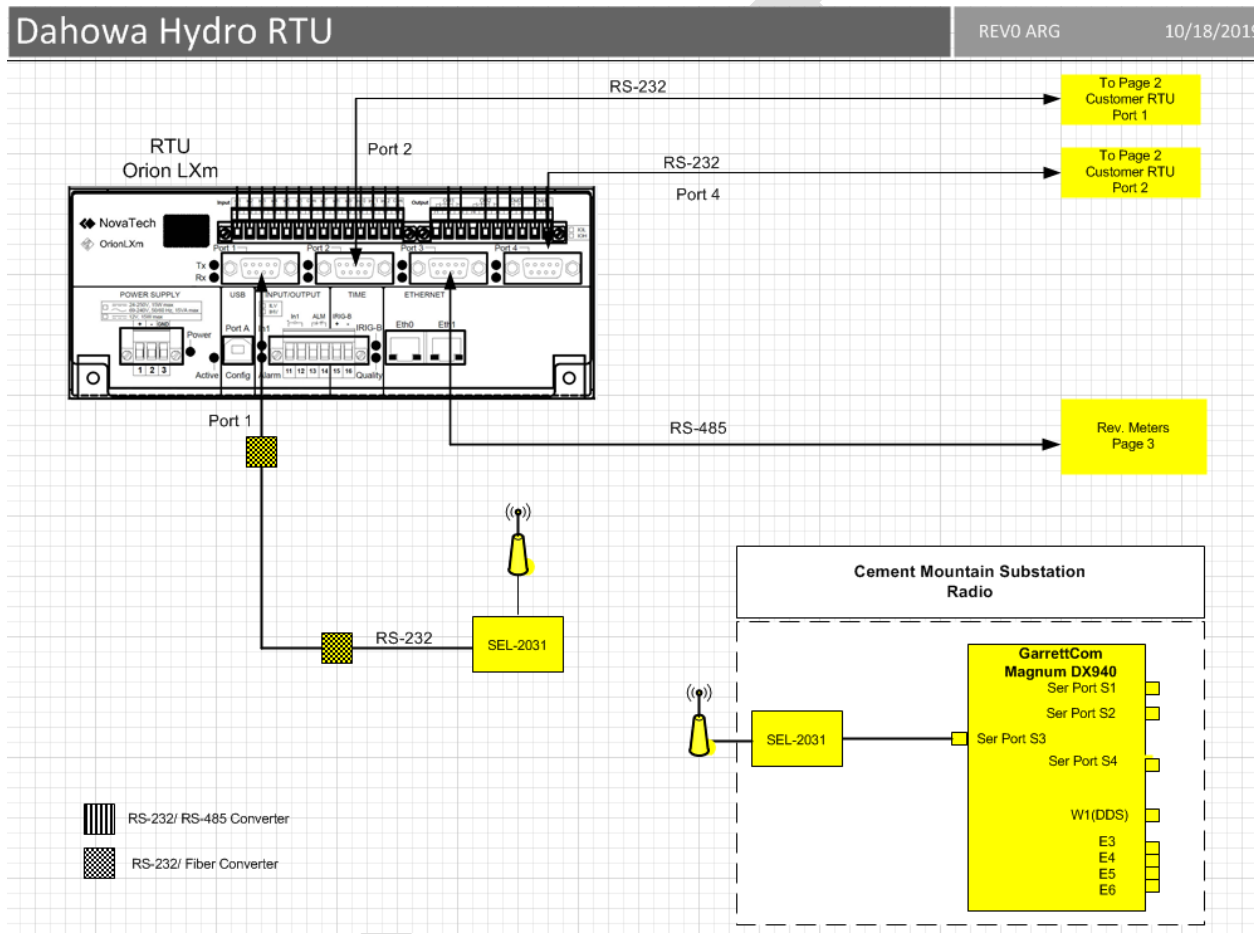

PRINTED COPIES ARE NOT DOCUMENT CONTROLLED.

File: Dahowa_Hydro_Generator 12265 Kw_Ny-20627_Scada Document_10_18_19	Originating Department: Retail Connections Eng.	Sponsor: Neil LaBrake-Jr.
--	--	------------------------------

nationalgrid	<b>ENGINEERING DOCUMENT</b> Distributed Generation Specification	Page 13 of 17
	<b>SCADA Communications Requirements</b>	Version 2.0
	<b>NY- 20627 Dahowa Hydro</b> 12,265 kW Hydro-Electric Generator, Greenwich, NY	10/18/2019

Final proposal

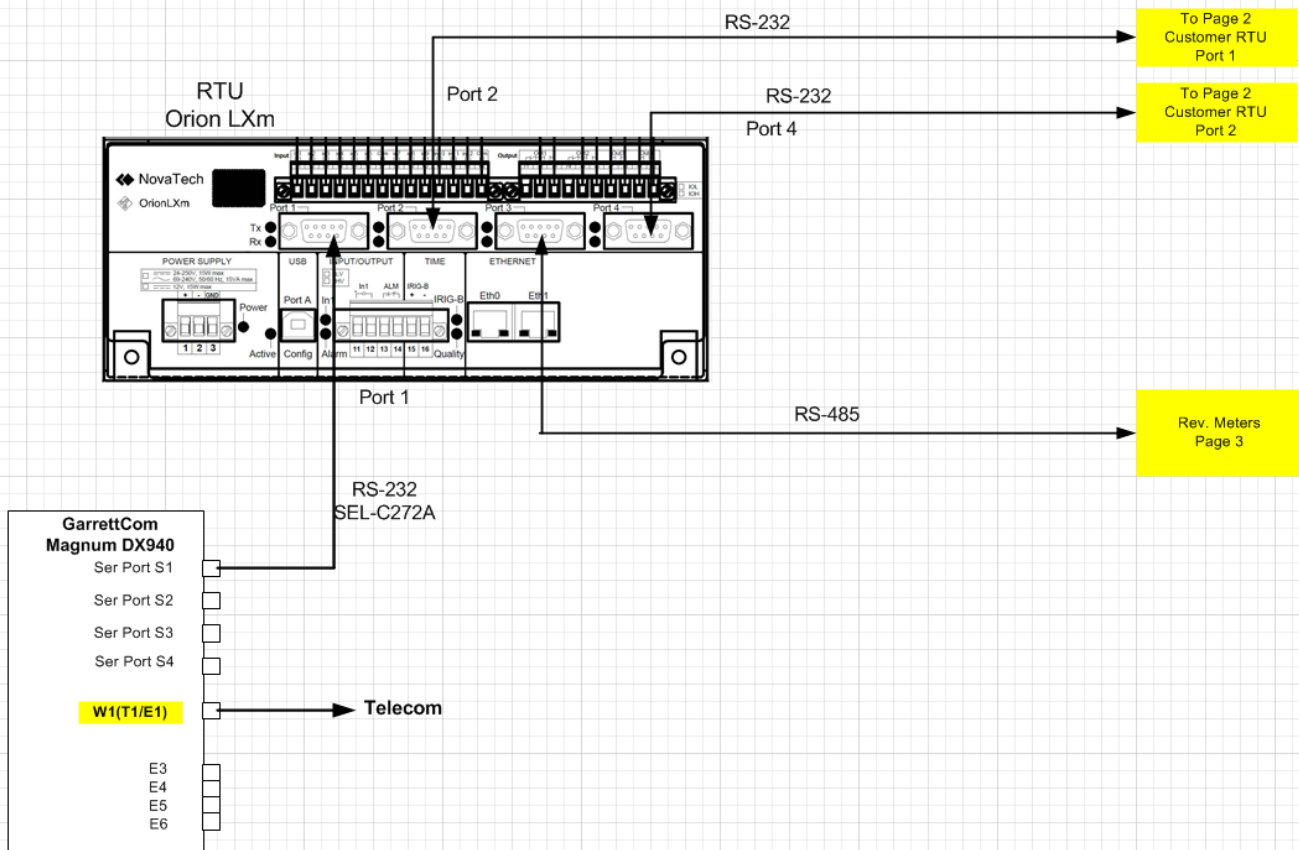

nationalgrid	<b>ENGINEERING DOCUMENT</b> Distributed Generation Specification	Page 14 of 17
	SCADA Communications Requirements	Version 2.0
	NY- 20627 Dahowa Hydro 12,265 kW Hydro-Electric Generator, Greenwich, NY	10/18/2019

Figure 2 - Customer to RTU Functional Diagram

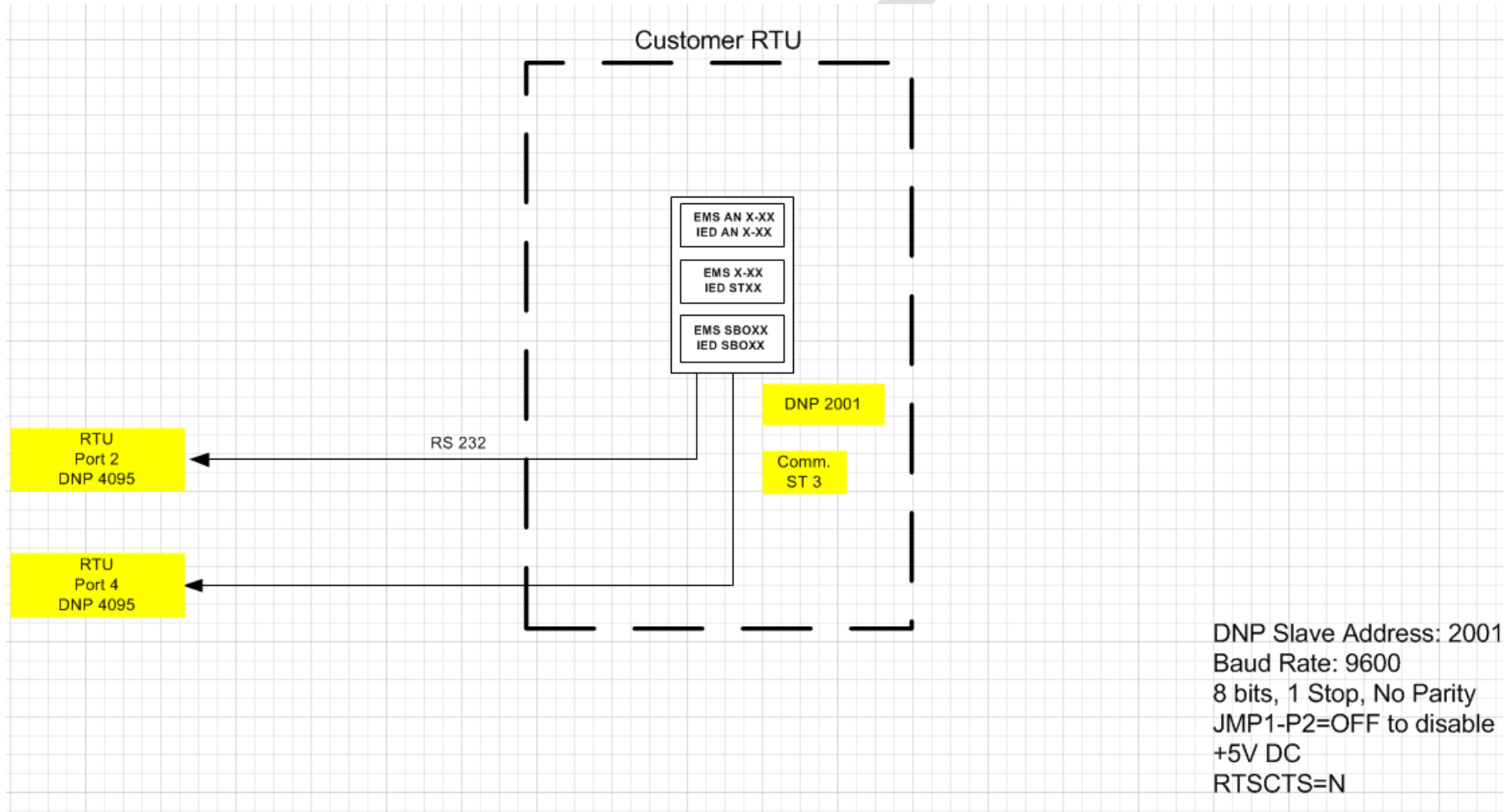

PRINTED COPIES ARE NOT DOCUMENT CONTROLLED.		
File: Dahowa_Hydro_Generator 12265 Kw_Ny-20627_Scada Document_10_18_19	Originating Department: Retail Connections Eng.	Sponsor: Neil LaBrake-Jr.



nationalgrid	<b>ENGINEERING DOCUMENT</b> Distributed Generation Specification	Page 15 of 17
	SCADA Communications Requirements	Version 2.0
	NY- 20627 Dahowa Hydro 12,265 kW Hydro-Electric Generator, Greenwich, NY	10/18/2019

Figure 3 – Revenue Meter

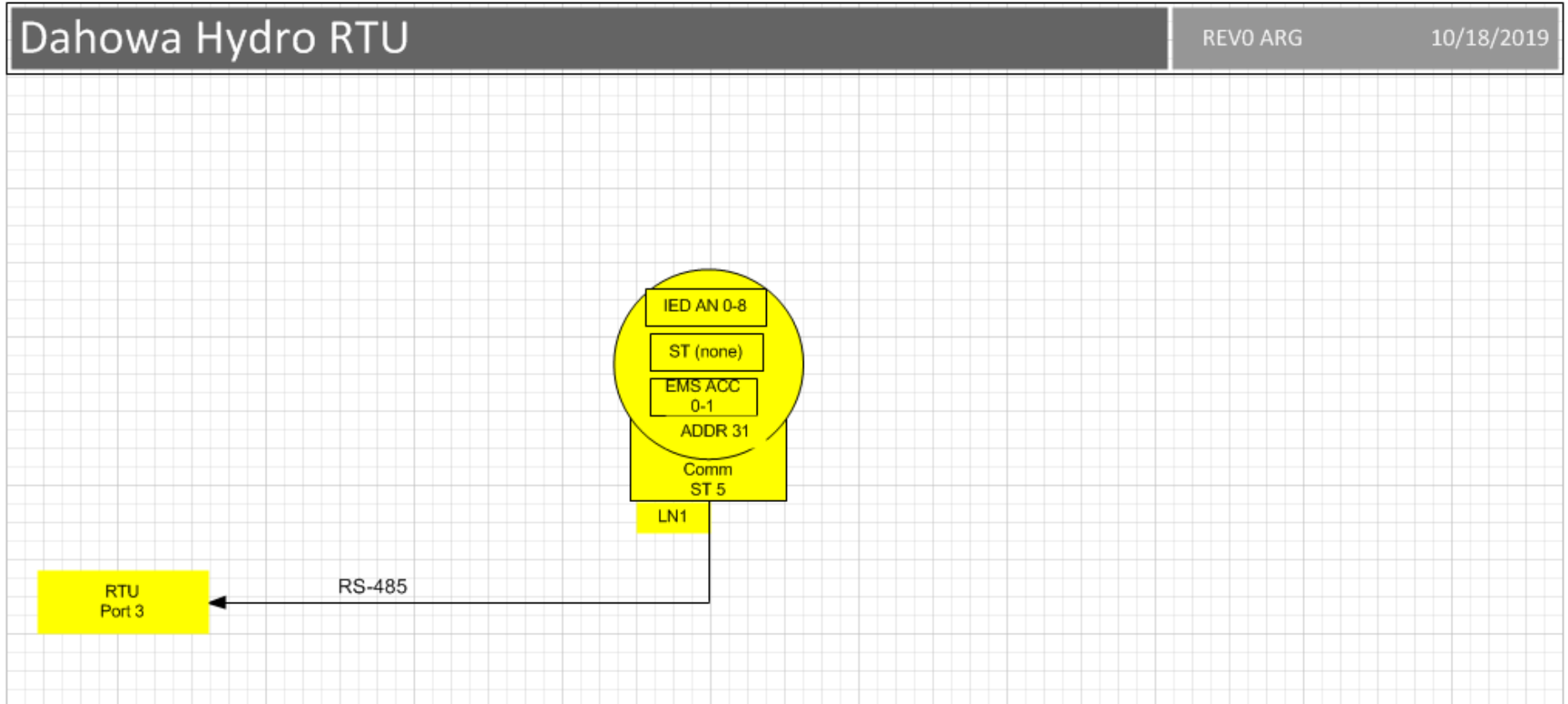

PRINTED COPIES ARE NOT DOCUMENT CONTROLLED.

File: Dahowa_Hydro_Generator 12265 Kw_Ny-20627_Scada Document_10_18_19	Originating Department: Retail Connections Eng.	Sponsor: Neil LaBrake-Jr.
--	--	------------------------------

nationalgrid	<b>ENGINEERING DOCUMENT</b> Distributed Generation Specification	Page 16 of 17
	<b>SCADA Communications Requirements</b>	Version 2.0
	<b>NY- 20627 Dahowa Hydro</b> 12,265 kW Hydro-Electric Generator, Greenwich, NY	10/18/2019

**Figure 4 – Interconnection Plan**

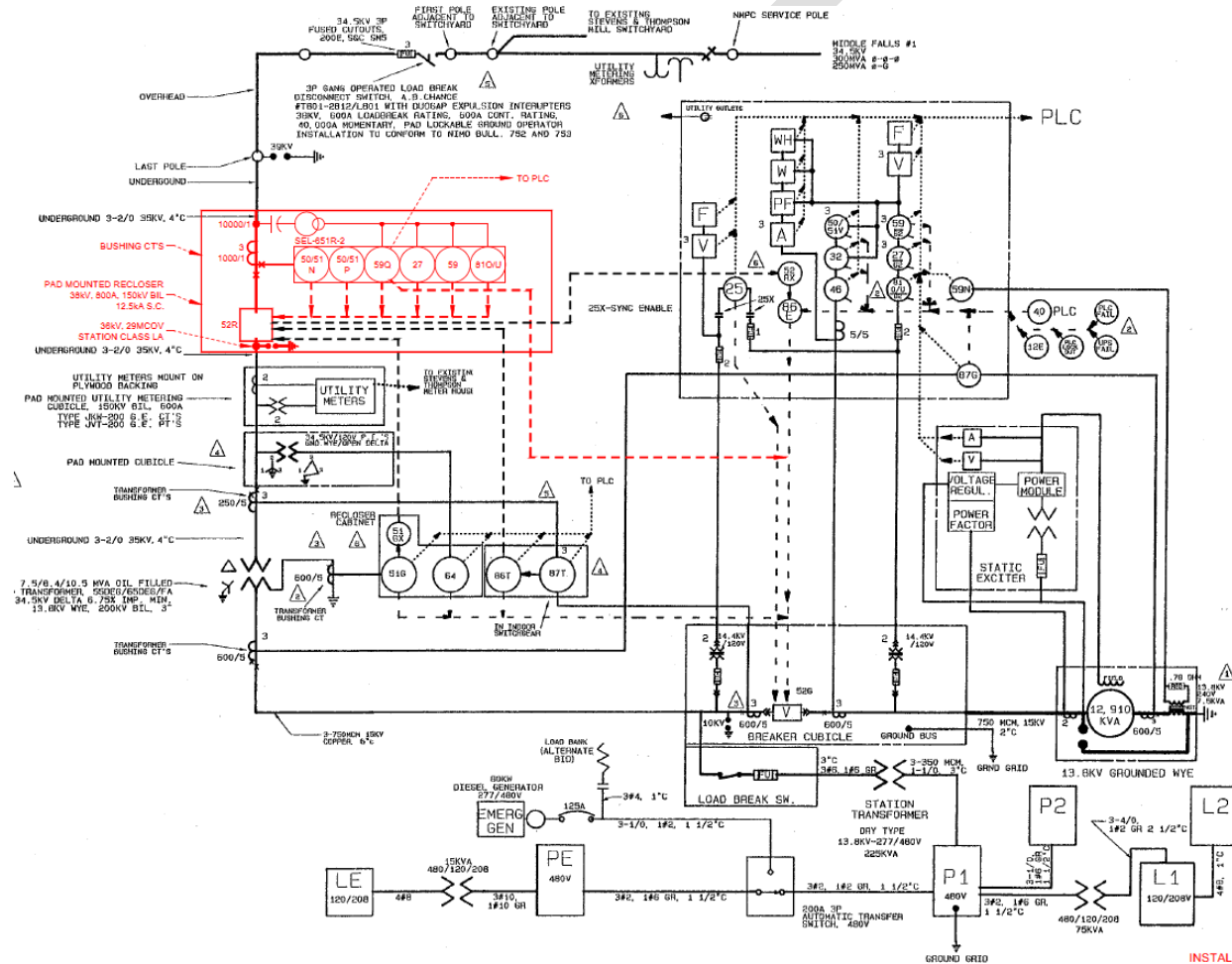

PRINTED COPIES ARE NOT DOCUMENT CONTROLLED.

File: Dahowa_Hydro_Generator 12265 Kw_Ny-20627_Scada Document_10_18_19	Originating Department: Retail Connections Eng.	Sponsor: Neil LaBrake-Jr.
--	--	------------------------------

nationalgrid	<b>ENGINEERING DOCUMENT</b>	Page 17 of 17
	<b>Distributed Generation Specification</b>	Version 2.0
	<b>SCADA Communications Requirements</b>	
	<b>NY- 20627 Dahowa Hydro</b>	01/14/2019
	<b>12,265 kW Hydro-Electric Generator,</b>	
	<b>Greenwich, NY</b>	

**Figure 5 – RTU Cabinet Layout**

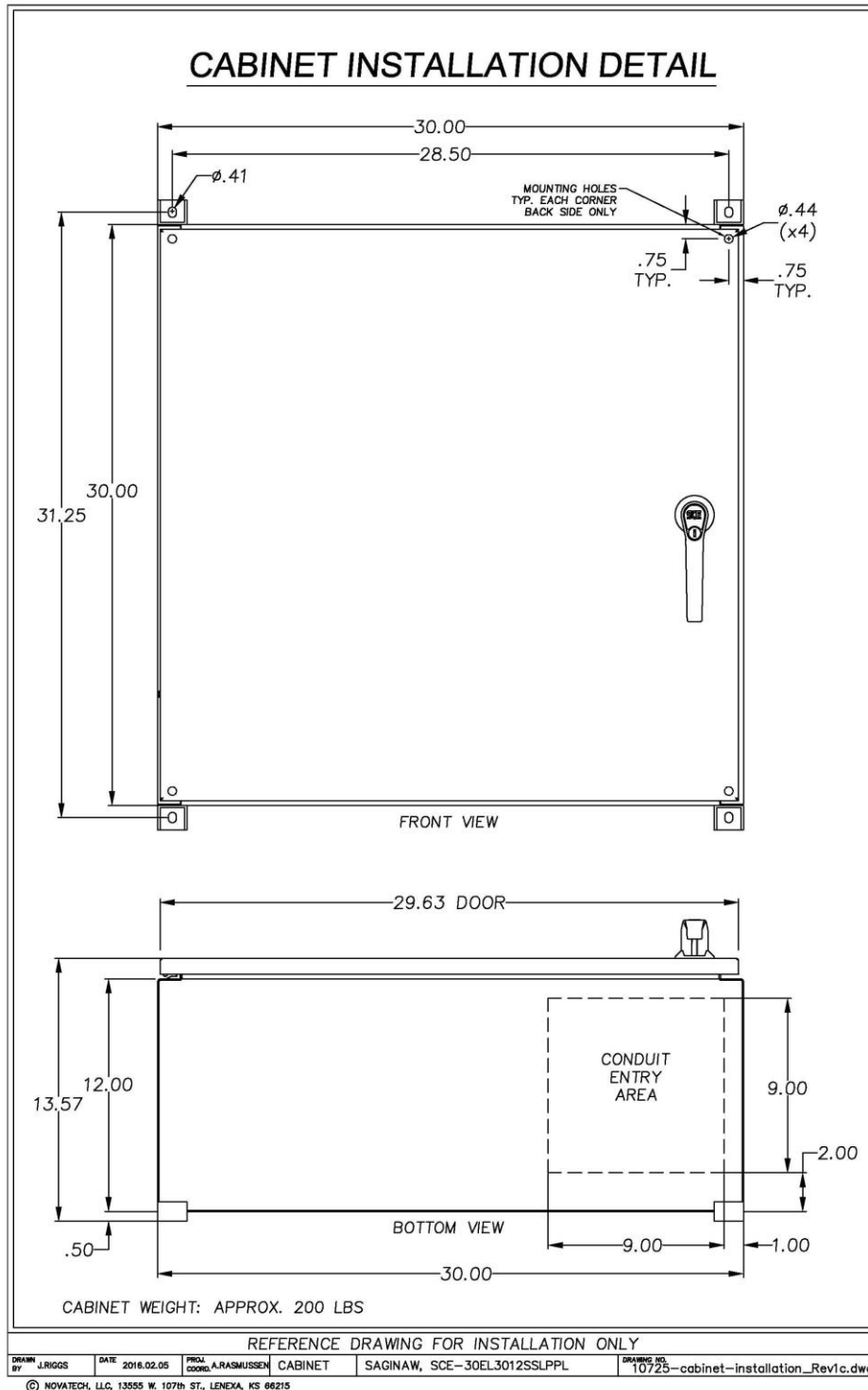

PRINTED COPIES ARE NOT DOCUMENT CONTROLLED.

File: Dahowa_Hydro_Generator 12265 Kw_Ny-20627_Scada Document_10_18_19	Originating Department: Retail Connections Eng.	Sponsor: Neil LaBrake-Jr.
--	--	------------------------------