

Attachment II

~~Appendix 6—STANDARD LARGE GENERATOR~~TRANSMISSION FACILITY
INTERCONNECTION AGREEMENT

~~(Applicable to Generating Facilities that exceed 20 MW)~~

by and among the

NEW YORK INDEPENDENT SYSTEM OPERATOR, INC.,

NEW YORK STATE ELECTRIC & GAS CORPORATION,

and

TRANS-ALLEGHENY INTERSTATE LINE COMPANY

Dated as of August 6, 2015

TABLE OF CONTENTS

	Page Number
ARTICLE 1. DEFINITIONS.....	<u>12</u>
ARTICLE 2. EFFECTIVE DATE, TERM AND TERMINATION	<u>107</u>
2.1 Effective Date.....	10
2.2 Term of Agreement.....	10
2.3 Termination.....	11
2.4 Termination Costs.....	11
2.5 Disconnection.....	12
2.6 Survival.....	12
ARTICLE 3. REGULATORY FILINGS	<u>1210</u>
3.1 Filing.....	12
ARTICLE 4. SCOPE OF INTERCONNECTION SERVICE.....	<u>1310</u>
4.1 Provision of Service.....	13
4.2 No Transmission Delivery Service.....	13
4.3 No Other Services.....	13
ARTICLE 5. INTERCONNECTION FACILITIES ENGINEERING, PROCUREMENT, AND CONSTRUCTION <u>SYSTEM UPGRADE FACILITIES</u> <u>ENGINEERING, PROCUREMENT, AND CONSTRUCTION</u>	<u>11</u>
5.1 Options.....	13
5.2 General Conditions Applicable to Option to Build.....	15
5.3 Liquidated Damages.....	16
5.4 Power System Stabilizers.....	17
5.5 Equipment Procurement.....	18
5.6 Construction Commencement.....	18
5.7 Work Progress.....	19
5.8 Information Exchange.....	19
5.9 Limited Operation.....	19
5.10 Developer’s Attachment Facilities (“DAF”).....	19
5.11 Connecting Transmission Owner’s Attachment Facilities Construction.....	20
5.12 Access Rights.....	21
5.13 Lands of Other Property Owners.....	21
5.14 Permits.....	21
5.15 Early Construction of Base Case Facilities.....	21
5.16 Suspension.....	22
5.17 Taxes.....	22
5.18 Tax Status; Non-Jurisdictional Entities.....	27
5.19 Modification.....	27
ARTICLE 6. TESTING AND INSPECTION.....	<u>2928</u>

6.1	Pre-Commercial Operation Date Testing and Modifications.....	28
6.2	Post-Commercial Operation Date Testing and Modifications.....	29
6.3	Right to Observe Testing.....	29
6.4	Right to Inspect.....	29
ARTICLE 7. METERING		<u>2931</u>
7.1	General.....	29
7.2	Check Meters.....	30
7.3	Standards.....	30
7.4	Testing of Metering Equipment.....	30
7.5	Metering Data.....	31
ARTICLE 8. COMMUNICATIONS 31		<u>33</u>
8.1	Developer Obligations.....	31
8.2	Remote Terminal Unit.....	31
8.3	No Annexation.....	32
ARTICLE 9. OPERATIONS.....		<u>3234</u>
9.1	General.....	32
9.2	NYISO and Connecting Transmission Owner Obligations.....	32
9.3	Developer Obligations.....	32
9.4	Start Up and Synchronization.....	32
9.5	Real and Reactive Power Control.....	33
9.6	Outages and Interruptions.....	34
9.7	Switching and Tagging Rules.....	37
9.8	Use of Attachment Facilities by Third Parties.....	37
9.9	Disturbance Analysis Data Exchange.....	38
ARTICLE 10. MAINTENANCE 38		<u>42</u>
10.1	Connecting Transmission Owner Obligations.....	38
10.2	Developer Obligations.....	38
10.3	Coordination.....	38
10.4	Secondary Systems.....	38
10.5	Operating and Maintenance Expenses.....	39
ARTICLE 11. PERFORMANCE OBLIGATION 39		<u>44</u>
11.1	Developer Attachment Facilities.....	39
11.2	Connecting Transmission Owner's Attachment Facilities.....	39
11.3	System Upgrade Facilities and System Deliverability Upgrades.....	39
11.4	Special Provisions for Affected Systems.....	39
11.5	Provision of Security.....	39
11.6	Developer Compensation for Emergency Services.....	40
11.7	Line Outage Costs.....	40
ARTICLE 12. INVOICE		<u>4044</u>

12.1	General	40
12.2	Final Invoice	41
12.3	Payment	41
12.4	Disputes	41
ARTICLE 13. EMERGENCIES		<u>4145</u>
13.1	Obligations	41
13.2	Notice	42
13.3	Immediate Action	42
13.4	NYISO and Connecting Transmission Owner Authority	42
13.5	Developer Authority	43
13.6	Limited Liability	43
ARTICLE 14. REGULATORY REQUIREMENTS AND GOVERNING LAW 43		<u>47</u>
14.1	Regulatory Requirements	43
14.2	Governing Law	44
ARTICLE 15. NOTICES		<u>4448</u>
15.1	General	44
15.2	Billings and Payments	44
15.3	Alternative Forms of Notice	44
15.4	Operations and Maintenance Notice	44
ARTICLE 16. FORCE MAJEURE 45		<u>49</u>
16.1	Force Majeure	45
ARTICLE 17. DEFAULT		<u>4550</u>
17.1	Default	45
ARTICLE 18. INDEMNITY, CONSEQUENTIAL DAMAGES AND INSURANCE 46		
<u>INDEMNITY, LIMITATION OF LIABILITY, AND INSURANCE</u>		<u>51</u>
18.1	Indemnity	46
18.2	No Consequential Damages	47
18.3	Insurance	47
ARTICLE 19. ASSIGNMENT		<u>4957</u>
19.1	Assignment	49
ARTICLE 20. SEVERABILITY		<u>5058</u>
20.1	Severability	50
ARTICLE 21. COMPARABILITY		<u>5058</u>
21.1	Comparability	50
ARTICLE 22. CONFIDENTIALITY		<u>5058</u>
22.1	Confidentiality	50
ARTICLE 23. ENVIRONMENTAL RELEASES		<u>5364</u>
23.1	Developer and Connecting Transmission Owner Notice	53
ARTICLE 24. <u>[RESERVED]</u> INFORMATION REQUIREMENT		<u>5465</u>
24.1	Information Acquisition	54

24.2	Information Submission by Connecting Transmission Owner.....	54
24.3	Updated Information Submission by Developer.....	54
24.4	Information Supplementation.....	55
ARTICLE 25. INFORMATION ACCESS AND AUDIT RIGHTS.....		<u>5565</u>
25.1	Information Access.....	55
25.2	Reporting of Non-Force Majeure Events.....	56
25.3	Audit Rights.....	56
25.4	Audit Rights Periods.....	56
25.5	Audit Results.....	57
ARTICLE 26. SUBCONTRACTORS		<u>5768</u>
26.1 General. 57		
26.2	Responsibility of Principal.....	57
26.3	No Limitation by Insurance.....	57
ARTICLE 27. DISPUTES		<u>5768</u>
27.1	Submission.....	57
27.2	External Arbitration Procedures.....	58
27.3	Arbitration Decisions.....	58
27.4	Costs.....	58
27.5	Termination.....	58
ARTICLE 28. REPRESENTATIONS, WARRANTIES AND COVENANTS 58.....		<u>70</u>
28.1	General.....	58
ARTICLE 29. MISCELLANEOUS 59		<u>72</u>
29.1	Binding Effect.....	59
29.2	Conflicts.....	59
29.3	Rules of Interpretation.....	60
29.4	Compliance.....	60
29.5	Joint and Several Obligations.....	60
29.6	Entire Agreement.....	60
29.7	No Third Party Beneficiaries.....	61
29.8	Waiver.....	61
29.9	Headings.....	61
29.10	Multiple Counterparts.....	61
29.11	Amendment.....	61
29.12	Modification by the Parties.....	61
29.13	Reservation of Rights.....	62
29.14	No Partnership.....	62
29.15	Other Transmission Rights.....	62
<u>APPENDIX A – ATTACHMENT FACILITIES AND SYSTEM UPGRADE FACILITIES</u>		<u>78</u>
Appendices <u>APPENDIX B – MILESTONES</u>		<u>84</u>

<u>APPENDIX C – INTERCONNECTION AND CONSTRUCTION PROVISIONS</u>	<u>85</u>
<u>APPENDIX D – SECURITY ARRANGEMENTS DETAILS</u>	<u>90</u>
<u>APPENDIX E – ADDRESSES FOR DELIVERY OF NOTICES AND BILLINGS</u>	<u>91</u>

~~STANDARD LARGE GENERATOR~~TRANSMISSION FACILITY
INTERCONNECTION AGREEMENT

~~THIS STANDARD LARGE GENERATOR~~TRANSMISSION FACILITY
INTERCONNECTION AGREEMENT (“Agreement”) is made and entered into this 6th
day of 20 August 2015, by and among _____, a ~~[corporate description]~~
~~organized and existing under the laws of the State/Commonwealth of _____ (“Developer”~~
~~with a Large Generating Facility)~~, the New York Independent System Operator, Inc. (“NYISO”),
a not-for-profit corporation organized and existing under the laws of the State of New York
(“NYISO”), and _____ a ~~[corporate description]~~, New York State Electric & Gas
Corporation (“NYSEG”), a corporation organized and existing under the laws of the State of
New York ~~(“Connecting Transmission Owner”). Developer, the NYISO, or Connecting~~
~~Transmission Owner, and Trans-Allegheny Interstate Line Company (“TrAILCo”), a corporation~~
organized and existing under the laws of the State of Maryland. NYSEG, NYISO or TrAILCo
each may be referred to as a “Party” or collectively referred to as the “Parties.” The terms
“Party” and “Parties” as used herein shall not include PJM Interconnection, L.L.C. (“PJM”) or
any successor Regional Transmission Organization.

RECITALS

WHEREAS, NYSEG is the owner of the Watercure Road to Homer City 345 kV transmission
line (the “Watercure Line”); and

~~WHEREAS, NYISO operates the New York State Transmission System and Connecting~~
~~Transmission Owner owns certain facilities included in the New York State Transmission~~
~~System; and~~

WHEREAS, the Watercure Line is operated by, and under the functional control of, the New
York Independent System Operator, Inc. (“NYISO”), and the Watercure Line is considered part
of the New York State Transmission System; and

WHEREAS, TrAILCo is the owner of the Mainesburg 345 kV-115 kV substation (the
“Mainesburg Substation” or “Transmission Facility”); and

~~WHEREAS, Developer intends to own, lease and/or control and operate the Generating Facility~~
~~identified as a Large Generating Facility in Appendix C to this Agreement; and,~~

WHEREAS, once in service, the Mainesburg Substation will be operated by, and under the
functional control of, PJM and is considered part of the PJM Transmission System; and

~~WHEREAS, Developer, NYISO, and Connecting Transmission Owner~~NYSEG and TrAILCo
have agreed to enter into this Agreement for the purpose of interconnecting the ~~Large Generating~~
~~Facility with~~Mainesburg Substation to the New York State Transmission System; and

WHEREAS, the interconnection of the Mainesburg Substation will entail electrically bifurcating
the Watercure Line into two segments: (a) the Watercure Road to Mainesburg Substation

segment (the “WRM Segment”); and (b) the Mainesburg Substation to Homer City segment (the “MHC Segment”); and

WHEREAS, the WRM Segment and the MHC Segment shall each be owned by NYSEG and under the functional control of the NYISO; and

WHEREAS, the interconnection of the Mainesburg Substation to the Watercure Line has been studied by TrAILCo and the results of that study are reflected in a “Facilities Study-Final” report dated June 12, 2015; and

WHEREAS, PJM is a signatory to this Agreement consistent with *American Electric Power Service Corporation*, 112 FERC ¶ 61,128 at P 10 (2005), to ensure that PJM is kept fully apprised of the matters addressed herein so that PJM may be kept aware of any reliability and planning issues that may arise.

NOW, THEREFORE, in consideration of and subject to the mutual covenants contained herein, it is agreed:

ARTICLE 1. DEFINITIONS

Whenever used in this Agreement with initial capitalization, the following terms shall have the meanings specified in this Article 1. Terms used in this Agreement with initial capitalization that are not defined in this Article 1 shall have the meanings specified in ~~Section 30.1.0 of Attachment X or Section 25.1 of Attachment S of the~~ the NYISO Open-Access Transmission Tariff (“NYISO OATT”).

Affected System shall mean an electric system other than the transmission system owned, controlled or operated by ~~the Connecting Transmission Owner~~ a Party that may be affected by the proposed interconnection.

~~**Affected System Operator** shall mean the entity that operates an Affected System.~~

~~**Affected Transmission Owner** shall mean the New York public utility or authority (or its designated agent) other than the Connecting Transmission Owner that (i) owns facilities used for the transmission of Energy in interstate commerce and provides Transmission Service under the Tariff, and (ii) owns, leases or otherwise possesses an interest in a portion of the New York State Transmission System where System Deliverability Upgrades or System Upgrade Facilities are installed pursuant to Attachment X and Attachment S of the Tariff.~~

Affiliate shall mean, with respect to a person or entity, any individual, corporation, partnership, firm, joint venture, association, joint-stock company, trust or unincorporated organization, directly or indirectly controlling, controlled by, or under common control with, such person or entity. The term “control” shall mean the possession, directly or indirectly, of the power to

direct the management or policies of a person or an entity. A voting interest of ten percent or more shall create a rebuttable presumption of control.

~~**Ancillary Services** shall mean those services that are necessary to support the transmission of Capacity and Energy from resources to Loads while maintaining reliable operation of the New York State Transmission System in accordance with Good Utility Practice.~~

Applicable Laws and Regulations shall mean all duly promulgated applicable federal, state and local laws, regulations, rules, ordinances, codes, decrees, judgments, directives, or judicial or administrative orders, permits and other duly authorized actions of any Governmental Authority, including but not limited to Environmental Law.

Applicable Reliability Councils shall mean the NERC, [ReliabilityFirst, PJM](#), the NPCC and the NYSRC.

Applicable Reliability Standards shall mean the requirements and guidelines of the Applicable Reliability Councils, ~~and the Transmission District to which the Developer's Large Generating Facility is directly interconnected,~~ as those requirements and guidelines are amended and modified and in effect from time to time; provided that no Party shall waive its right to challenge the applicability or validity of any requirement or guideline as applied to it in the context of this Agreement.

~~**Attachment Facilities** shall mean the Connecting Transmission Owner's Attachment Facilities and the Developer's Attachment Facilities. Collectively, Attachment Facilities include all facilities and equipment between the Large Generating Facility and the Point of Interconnection, including any modification, additions or upgrades that are necessary to physically and electrically interconnect the Large Generating Facility to the New York State Transmission System. Attachment Facilities are sole-use facilities and shall not include Stand Alone System Upgrade Facilities, Distribution Upgrades, System Upgrade Facilities or System Deliverability Upgrades.~~

~~**Base Case** shall mean the base case power flow, short circuit, and stability data bases used for the Interconnection Studies by NYISO, Connecting Transmission Owner or Developer; described in Section 30.2.3 of the Large Facility Interconnection Procedures.~~

Breach shall mean the failure of a Party to perform or observe any material term or condition of this Agreement.

Breaching Party shall mean a Party that is in Breach of this Agreement.

Business Day shall mean Monday through Friday, excluding federal holidays.

~~**Byway** shall mean all transmission facilities comprising the New York State Transmission System that are neither Highways nor Other Interfaces. All transmission facilities in Zone J and Zone K are Byways.~~

Calendar Day shall mean any day including Saturday, Sunday or a federal holiday.

~~**Capacity Region** shall mean one of four subsets of the Installed Capacity statewide markets comprised of (1) Rest of State (i.e., Load Zones A through F); (2) Lower Hudson Valley (i.e., Load Zones G, H and I); (3) New York City (i.e., Load Zone J); and (4) Long Island (i.e., Load Zone K), except for Class Year Interconnection Facility Studies conducted prior to Class Year 2012, for which “Capacity Region” shall be defined as set forth in Section 25.7.3 of Attachment S to the NYISO OATT.~~

~~**Capacity Resource Interconnection Service (“CRIS”)** shall mean the service provided by NYISO to interconnect the Developer’s Large Generating Facility to the New York State Transmission System or to the Distribution System in accordance with the NYISO Deliverability Interconnection Standard, to enable the New York State Transmission System to deliver electric capacity from the Large Generating Facility, pursuant to the terms of the NYISO OATT.~~

~~**Class Year Deliverability Study** shall mean an assessment, conducted by the NYISO staff in cooperation with Market Participants, to determine the System Deliverability Upgrades required for each generation and merchant transmission project included in the Class Year Interconnection Facilities Study to interconnect to the New York State Transmission System or to the Distribution System in compliance with the NYISO Deliverability Interconnection Standard.~~

~~**Clustering** shall mean the process whereby a group of Interconnection Requests is studied together, instead of serially, for the purpose of conducting the Interconnection System Reliability Impact Study.~~

Commercial Operation shall mean the status of a Large Generating Facility that has the interconnection of the Mainesburg Substation to the Watercure Line at the Point(s) of Interconnection, and the energization of the Mainesburg Substation, which points and substation have commenced generating/transmitting electricity for sale, excluding electricity generated/transmitted during Trial Operation.

Commercial Operation Date ~~of a unit~~ shall mean the date on which the ~~Large Generating Facility commences~~ Point(s) of Interconnection and the Mainesburg Substation have achieved Commercial Operation as agreed to by the Parties ~~pursuant to Appendix E to this Agreement.~~

Confidential Information shall mean any information that is defined as confidential by Article 22 of this Agreement.

~~**Connecting Transmission Owner** shall mean the New York public utility or authority (or its designated agent) that (i) owns facilities used for the transmission of Energy in interstate commerce and provides Transmission Service under the Tariff, (ii) owns, leases or otherwise possesses an interest in the portion of the New York State Transmission System or Distribution System at the Point of Interconnection, and (iii) is a Party to the Standard Large Interconnection Agreement.~~

~~**Connecting Transmission Owner's Attachment Facilities** shall mean all facilities and equipment owned, controlled or operated by the Connecting Transmission Owner from the Point of Change of Ownership to the Point of Interconnection as identified in Appendix A to the Standard Large Generator Interconnection Agreement, including any modifications, additions or upgrades to such facilities and equipment. Connecting Transmission Owner's Attachment Facilities are sole use facilities and shall not include Stand Alone System Upgrade Facilities or System Upgrade Facilities.~~

Control Area shall mean an electric power system or combination of electric power systems to which a common automatic generation control scheme is applied in order to: (1) match, at all times, the power output of the ~~Generators~~generators within the electric power system(s) and capacity and energy purchased from entities outside the electric power system(s), with the Load within the electric power system(s); (2) maintain scheduled interchange with other Control Areas, within the limits of Good Utility Practice; (3) maintain the frequency of the electric power system(s) within reasonable limits in accordance with Good Utility Practice; and (4) provide sufficient generating capacity to maintain Operating Reserves in accordance with Good Utility Practice. A Control Area must be certified by the NPCC or ReliabilityFirst, as applicable.

Default shall mean the failure of a Party in Breach of this Agreement to cure such Breach in accordance with Article 17 of this Agreement.

~~**Deliverability Interconnection Standard** shall mean the standard that must be met by any Large Generating Facility proposing to interconnect to the New York State Transmission System or to the Distribution System and become a qualified Installed Capacity Supplier. To meet the NYISO Deliverability Interconnection Standard, the Developer of the proposed Large Generating Facility must, in accordance with the rules in Attachment S to the NYISO OATT, fund or commit to fund the System Deliverability Upgrades identified for its project in the Class Year Deliverability Study.~~

~~**Developer** shall mean an Eligible Customer developing a Large Generating Facility, proposing to connect to the New York State Transmission System, in compliance with the NYISO Minimum Interconnection Standard.~~

~~**Developer's Attachment Facilities** shall mean all facilities and equipment, as identified in Appendix A of this Agreement, that are located between the Large Generating Facility and the Point of Change of Ownership, including any modification, addition, or upgrades to such facilities and equipment necessary to physically and electrically interconnect the Large Generating Facility to the New York State Transmission System. Developer's Attachment Facilities are sole use facilities.~~

Dispute Resolution shall mean the procedure described in Article 27 of this Agreement for resolution of a dispute between the Parties.

~~**Distribution System** shall mean the Transmission Owner's facilities and equipment used to distribute electricity that are subject to FERC jurisdiction, and are subject to the NYISO's LFIP~~

~~or SGIP under FERC Order Nos. 2003 and/or 2006. The term Distribution System shall not include LIPA's distribution facilities.~~

~~**Distribution Upgrades** shall mean the additions, modifications, and upgrades to the Connecting Transmission Owner's Distribution System at or beyond the Point of Interconnection to facilitate interconnection of a Large Facility or Small Generating Facility and render the transmission service necessary to affect the Developer's wholesale sale of electricity in interstate commerce. Distribution Upgrades do not include Interconnection Facilities, System Upgrade Facilities, or System Deliverability Upgrades. Distribution Upgrades are sole use facilities and shall not include Stand Alone System Upgrade Facilities, System Upgrade Facilities, or System Deliverability Upgrades.~~

Effective Date shall mean the date on which this Agreement becomes effective upon execution by the Parties, subject to acceptance by the Commission, or if filed unexecuted, upon the date specified by the Commission.

Emergency shall mean an any abnormal condition or situation which NYSEG or NYISO, in their sole discretion, deems imminently likely to endanger life or property, or adversely affect or impair the New York State Transmission System, NYSEG's electrical system, or the electrical or transmission systems of others to which they are directly or indirectly connected, which requires immediate automatic or manual action to correct. Such an abnormal system condition or situation includes, without limitation, overloading or potential overloading (exceeding thermal limits of pre- and post-contingency), excessive voltage drop, exceeding voltage limits as defined by the NYISO or NYSEG, load shedding, voltage reduction, operating reserve deficiencies, frequency deviations, over-generation or other non-normal conditions. Economic hardships of either Party will not constitute an "Emergency."

Emergency State shall mean the condition or state that the New York State ~~Power System~~Transmission System, or the PJM Transmission System, as applicable, is in when an abnormal condition occurs that requires automatic or immediate manual action to prevent or limit loss of the New York State Transmission System or ~~Generators~~the PJM Transmission System, or generators that could adversely affect the reliability of the New York State ~~Power System~~Transmission System, or the PJM Transmission System, as applicable.

~~**Energy Resource Interconnection Service ("ERIS")** shall mean the service provided by NYISO to interconnect the Developer's Large Generating Facility to the New York State Transmission System or to the Distribution System in accordance with the NYISO Minimum Interconnection Standard, to enable the New York State Transmission System to receive Energy and Ancillary Services from the Large Generating Facility, pursuant to the terms of the NYISO OATT.~~

~~**Engineering & Procurement (E&P) Agreement** shall mean an agreement that authorizes Connecting Transmission Owner to begin engineering and procurement of long lead-time items necessary for the establishment of the interconnection in order to advance the implementation of the Interconnection Request.~~

Environmental Law shall mean Applicable Laws or Regulations relating to pollution or protection of the environment or natural resources.

Federal Power Act or FPA shall mean the Federal Power Act, as amended, 16 U.S.C. §§ 791a et seq. (~~“FPA”~~).

FERC or Commission shall mean the Federal Energy Regulatory Commission (~~“Commission”~~) or its successor.

Force Majeure shall mean any act of God, labor disturbance, act of the public enemy, war, insurrection, riot, fire, storm or flood, explosion, breakage or accident to machinery or equipment, any order, regulation or restriction imposed by governmental, military or lawfully established civilian authorities, or any other cause beyond a Party’s control. A Force Majeure event does not include acts of negligence or intentional wrongdoing by the Party claiming Force Majeure.

~~**Generating Facility** shall mean Developer’s device for the production of electricity identified in the Interconnection Request, but shall not include the Developer’s Attachment Facilities or Distribution Upgrades.~~

~~**Generating Facility Capacity** shall mean the net seasonal capacity of the Generating Facility and the aggregate net seasonal capacity of the Generating Facility where it includes multiple energy production devices.~~

Good Utility Practice shall mean any of the practices, methods and acts engaged in or approved by a significant portion of the electric industry during the relevant time period, or any of the practices, methods and acts which, in the exercise of reasonable judgment in light of the facts known at the time the decision was made, could have been expected to accomplish the desired result at a reasonable cost consistent with good business practices, reliability, safety and expedition. Good Utility Practice is not intended to be limited to the optimum practice, method, or act to the exclusion of all others, but rather to delineate acceptable practices, methods, or acts generally accepted in the region.

Governmental Authority shall mean any federal, state, local or other governmental regulatory or administrative agency, court, commission, department, board, or other governmental subdivision, legislature, rulemaking board, tribunal, or other governmental authority having jurisdiction over any of the Parties, their respective facilities, or the respective services they provide, and exercising or entitled to exercise any administrative, executive, police, or taxing authority or power; provided, however, that such term does not include ~~Developer~~ NYSEG, TrAILCo, NYISO, ~~Affected Transmission Owner, Connecting Transmission Owner, PJM~~ or any Affiliate thereof.

Hazardous Substances shall mean any chemicals, materials or substances defined as or included in the definition of “hazardous substances,” “hazardous wastes,” “hazardous materials,” “hazardous constituents,” “restricted hazardous materials,” “extremely hazardous substances,”

“toxic substances,” “radioactive substances,” “contaminants,” “pollutants,” “toxic pollutants” or words of similar meaning and regulatory effect under any applicable Environmental Law, or any other chemical, material or substance, exposure to which is prohibited, limited or regulated by any applicable Environmental Law.

~~**Highway** shall mean 115 kV and higher transmission facilities that comprise the following NYCA interfaces: Dysinger East, West Central, Volney East, Moses South, Central East/Total East and UPNY-ConEd, and their immediately connected, in-series, Bulk Power System facilities in New York State. Each interface shall be evaluated to determine additional “in-series” facilities, defined as any transmission facility higher than 115 kV that (a) is located in an upstream or downstream zone adjacent to the interface and (b) has a power transfer distribution factor (DFAX) equal to or greater than five percent when the aggregate of generation in zones or systems adjacent to the upstream zone or zones which define the interface is shifted to the aggregate of generation in zones or systems adjacent to the downstream zone or zones which define the interface. In determining “in-series” facilities for Dysinger East and West Central interfaces, the 115 kV and 230 kV tie lines between NYCA and PJM located in LBMP Zones A and B shall not participate in the transfer. Highway transmission facilities are listed in ISO Procedures.~~

Initial ~~Synchronization~~Energization Date shall mean the date upon which the ~~Large Generating Facility~~Mainesburg Substation is initially ~~synchronized~~interconnected and energized with the New York State Transmission System and upon which Trial Operation begins.

~~**In-Service Date** shall mean the date upon which the Developer reasonably expects it will be ready to begin use of the Connecting Transmission Owner’s Attachment Facilities to obtain back feed power.~~

~~**Interconnection Facilities Study** shall mean a study conducted by NYISO or a third party consultant for the Developer to determine a list of facilities (including Connecting Transmission Owner’s Attachment Facilities, Distribution Upgrades, System Upgrade Facilities and System Deliverability Upgrades as identified in the Interconnection System Reliability Impact Study), the cost of those facilities, and the time required to interconnect the Large Generating Facility with the New York State Transmission System or with the Distribution System. The scope of the study is defined in Section 30.8 of the Standard Large Facility Interconnection Procedures.~~

~~**Interconnection Facilities Study Agreement** shall mean the form of agreement contained in Appendix 4 of the Standard Large Facility Interconnection Procedures for conducting the Interconnection Facilities Study.~~

~~**Interconnection Feasibility Study** shall mean a preliminary evaluation of the system impact and cost of interconnecting the Large Generating Facility to the New York State Transmission System or to the Distribution System, the scope of which is described in Section 30.6 of the Standard Large Facility Interconnection Procedures.~~

~~**Interconnection Feasibility Study Agreement** shall mean the form of agreement contained in Appendix 2 of the Standard Large Facility Interconnection Procedures for conducting the Interconnection Feasibility Study.~~

~~**Interconnection Request** shall mean a Developer's request, in the form of Appendix 1 to the Standard Large Facility Interconnection Procedures, in accordance with the Tariff, to interconnect a new Large Generating Facility to the New York State Transmission System or to the Distribution System, or to materially increase the capacity of, or make a material modification to the operating characteristics of, an existing Large Generating Facility that is interconnected with the New York State Transmission System or with the Distribution System.~~

~~**Interconnection Study** shall mean any of the following studies: the Interconnection Feasibility Study, the Interconnection System Reliability Impact Study, and the Interconnection Facilities Study described in the Standard Large Facility Interconnection Procedures.~~

~~**Interconnection System Reliability Impact Study ("SRIS")** shall mean an engineering study, conducted in accordance with Section 30.7 of the Large Facility Interconnection Procedures, that evaluates the impact of the proposed Large Generating Facility on the safety and reliability of the New York State Transmission System and, if applicable, an Affected System, to determine what Attachment Facilities, Distribution Upgrades and System Upgrade Facilities are needed for the proposed Large Generation Facility of the Developer to connect reliably to the New York State Transmission System or to the Distribution System in a manner that meets the NYISO Minimum Interconnection Standard.~~

~~**Interconnection System Reliability Impact Study Agreement** shall mean the form of agreement contained in Appendix 3 of the Standard Large Facility Interconnection Procedures for conducting the Interconnection System Reliability Impact Study.~~

IRS shall mean the Internal Revenue Service.

~~**Large Generating Facility** shall mean a Generating Facility having a Generating Facility Capacity of more than 20 MW.~~

Loss shall mean any and all ~~losses~~liabilities, damages, losses, claims, including claims relating to injury to or death of any person or damage to property, ~~demand~~demands, suits, recoveries, costs and expenses, court costs, ~~attorney~~attorneys' fees, and all other obligations by or to third parties, ~~arising out of or resulting from the Indemnified Party's performance or non-performance of its obligations under this Agreement on behalf of the Indemnifying Party, except in cases of gross negligence or intentional wrongdoing by the Indemnified Party.~~

~~**Material Modification** shall mean those modifications that have a material impact on the cost or timing of any Interconnection Request with a later queue priority date.~~

Metering Equipment shall mean all metering equipment installed or to be installed ~~at the Large Generating Facility~~ pursuant to this Agreement at the ~~metering points~~Point(s) of Interconnection,

including but not limited to instrument transformers, MWh-meters, data acquisition equipment, transducers, remote terminal unit, communications equipment, phone lines, and fiber optics.

~~**Minimum Interconnection Standard** shall mean the reliability standard that must be met by any Large Generating Facility proposing to connect to the New York State Transmission System or to the Distribution System. The Standard is designed to ensure reliable access by the proposed project to the New York State Transmission System. The Standard does not impose any deliverability test or deliverability requirement on the proposed interconnection.~~

NERC shall mean the North American Electric Reliability ~~Council~~[Corporation](#) or its successor organization.

New York State Transmission System shall mean the entire New York State electric transmission system, which includes: (i) the Transmission Facilities under ~~ISO~~[NYISO](#) Operational Control; (ii) the Transmission Facilities Requiring ~~ISO~~[NYISO](#) Notification; and (iii) all remaining transmission facilities within the New York Control Area.

Notice of Dispute shall mean a written notice of a dispute or claim that arises out of or in connection with this Agreement or its performance.

NPCC shall mean the Northeast Power Coordinating Council or its successor organization.

[NYISO shall mean the New York Independent System Operator, Inc. or its successor organization.](#)

[NYISO Tariff shall mean the NYISO Open Access Transmission Tariff \(“NYISO OATT”\), as filed with the Commission, and as amended or supplemented from time to time, or any successor tariff.](#)

NYSRC shall mean the New York State Reliability Council or its successor organization.

[Outage Start Date shall mean that date set forth in Appendix B to this Agreement.](#)

~~**Optional Interconnection Study** shall mean a sensitivity analysis based on assumptions specified by the Developer in the Optional Interconnection Study Agreement.~~

~~**Optional Interconnection Study Agreement** shall mean the form of agreement contained in Appendix 5 of the Standard Large Facility Interconnection Procedures for conducting the Optional Interconnection Study.~~

~~**Other Interfaces** shall mean the following interfaces into Capacity Regions: Lower Hudson Valley [*i.e.*, Rest of State (Load Zones A-F) to Lower Hudson Valley (Load Zones G, H and I)]; New York City [*i.e.*, Lower Hudson Valley (Load Zones G, H and I) to New York City (Load Zone J)]; and Long Island [*i.e.*, Lower Hudson Valley (Load Zones G, H and I) to Long Island (Load Zone K)], and the following Interfaces between the NYCA and adjacent Control Areas:-~~

~~PJM to NYISO, ISO-NE to NYISO, Hydro-Quebec to NYISO, and Norwalk Harbor (Connecticut) to Northport (Long Island) Cable.~~

Party or Parties shall mean NYSEG, NYISO, ~~Connecting Transmission Owner, or Developer~~ or TrAILCo, or any combination of the above.

PJM shall mean the PJM Interconnection, L.L.C. or its successor organization.

PJM Tariff shall mean the PJM OATT, as filed with the Commission, as amended or supplemented from time to time, or any successor tariff.

PJM Transmission System shall mean the transmission facilities under the operational control of PJM.

Point of Change of Ownership shall mean the ~~point~~point(s), as set forth in Figure 1 to Appendix A to this Agreement, where the ~~Developer's Attachment~~System Upgrade Facilities owned by TrAILCo connect to the ~~Connecting Transmission Owner's Attachment Facilities~~Watercure Line.

Point of Interconnection shall mean the ~~point~~point(s), as set forth in Figure 1 to Appendix A to this Agreement, where the ~~Attachment~~System Upgrade Facilities owned by TrAILCo connect to the New York State Transmission System ~~or to the Distribution System~~.

~~**Queue Position** shall mean the order of a valid Interconnection Request, relative to all other pending valid Interconnection Requests, that is established based upon the date and time of receipt of the valid Interconnection Request by NYISO.~~

Reasonable Efforts shall mean, with respect to an action required to be attempted or taken by a Party under this Agreement, efforts that are timely and consistent with Good Utility Practice and are otherwise substantially equivalent to those a Party would use to protect its own interests.

~~**Retired:** A Generator that has permanently ceased operating on or after May 1, 2015 either: i) pursuant to applicable notice; or ii) as a result of the expiration of its Mothball Outage or its ICAP Ineligible Forced Outage.~~

ReliabilityFirst shall mean the ReliabilityFirst Corporation or its successor organization.

~~**Scoping Meeting** shall mean the meeting between representatives of the Developer, NYISO and Connecting Transmission Owner conducted for the purpose of discussing alternative interconnection options, to exchange information including any transmission data and earlier study evaluations that would be reasonably expected to impact such interconnection options, to analyze such information, and to determine the potential feasible Points of Interconnection.~~

Services Tariff shall mean the NYISO Market Administration and Control Area Tariff, as filed with the Commission, and as amended or supplemented from time to time, or any successor tariff thereto.

~~Site Control shall mean documentation reasonably demonstrating: (1) ownership of, a leasehold interest in, or a right to develop a site for the purpose of constructing the Large Generating Facility; (2) an option to purchase or acquire a leasehold site for such purpose; or (3) an exclusivity or other business relationship between Developer and the entity having the right to sell, lease or grant Developer the right to possess or occupy a site for such purpose.~~

Stand Alone System Upgrade Facilities shall mean System Upgrade Facilities that ~~a Developer~~NYSEG may construct without affecting day-to-day operations of the New York State Transmission System during their construction, or that TrAILCo may construct without affecting day-to-day operations of the New York State Transmission System during their construction. ~~NYISO, the Connecting Transmission Owner and the Developer must agree as to what constitutes~~The Stand Alone System Upgrade Facilities ~~and identify them~~are identified in Appendix A to this Agreement.

~~Standard Large Facility Interconnection Procedures (“LFIP”) shall mean the interconnection procedures applicable to an Interconnection Request pertaining to a Large Generating Facility that are included in Attachment X of the NYISO OATT.~~

~~Standard Large Generator Interconnection Agreement (“LGIA”) shall mean this Agreement, the form of interconnection agreement applicable to an Interconnection Request pertaining to a Large Generating Facility, that is included in Attachment X of the NYISO OATT.~~

~~System Deliverability Upgrades shall mean the least costly configuration of commercially available components of electrical equipment that can be used, consistent with Good Utility Practice and Applicable Reliability Requirements, to make the modifications or additions to Byways and Highways and Other Interfaces on the existing New York State Transmission System and Distribution System that are required for the proposed project to connect reliably to the system in a manner that meets the NYISO Deliverability Interconnection Standard at the requested level of Capacity Resource Interconnection Service.~~

System Protection Facilities shall mean the equipment, including necessary protection signal communications equipment, required to (1) protect the New York State Transmission System from faults or other electrical disturbances occurring ~~at on~~ the Large Generating Facility and Watercure Line or the Mainesburg Substation, (2) protect the ~~Large Generating Facility~~Watercure Line from faults or other electrical system disturbances occurring on the New York State Transmission System or on other delivery systems or other generating systems to which the New York State Transmission System is directly connected, ~~(3) protect the PJM Transmission System from faults or other electrical disturbances occurring at the Mainesburg Substation or the Watercure Line, and (4) protect the Mainesburg Substation from faults or other electrical system disturbances occurring on the PJM Transmission System or on other delivery systems or other generating systems to which the PJM Transmission System is directly connected.~~

System Upgrade Facilities shall mean the least costly configuration of commercially available components of electrical equipment that can be used, consistent with Good Utility Practice and

Applicable Reliability Requirements, to make the modifications ~~to the existing transmission system~~ or additions to the New York State Transmission System, or the PJM Transmission System, as applicable, that are required to maintain system reliability due to: (i) changes in the system, including such changes as load growth and changes in load pattern, to be addressed in the form of generic generation or transmission projects; and (ii) proposed interconnections. ~~In the case of proposed interconnection projects, System Upgrade Facilities are the modifications or additions to the existing New York State Transmission System that are required for the proposed project to connect reliably to the system in a manner that meets the NYISO Minimum Interconnection Standard.~~

TrAILCo shall have the meaning set forth in the introductory paragraph of this Agreement, which entity owns, leases or otherwise possesses an interest in the portion of the PJM Transmission System, namely, the Transmission Facility, at the Point(s) of Interconnection.

Tariff Transmission Facility shall mean the ~~NYISO Open Access Transmission Tariff (“OATT”), as filed with the Commission, and as amended or supplemented from time to time, or any successor tariff~~ Mainesburg Substation.

Trial Operation shall mean the period during which ~~Developer~~ TrAILCo is engaged in ~~on-site~~ on-site test operations and commissioning of the ~~Large Generating~~ interconnection of the Transmission Facility to the Watercure Line prior to Commercial Operation.

Watercure Line shall mean NYSEG’s Watercure Road to Homer City 345 kV transmission line, which, upon the commercial operation of the Transmission Facility, shall be comprised of the WRM Segment and the MHC Segment.

ARTICLE 2. EFFECTIVE DATE, TERM AND TERMINATION

2.1 Effective Date.

This Agreement shall become effective upon execution by the Parties, subject to acceptance by FERC, or if filed unexecuted, upon the date specified by FERC. ~~The NYISO and Connecting Transmission Owner,~~ NYSEG and TrAILCo shall promptly file this Agreement with FERC upon execution in accordance with Article 3.1.

2.2 Term of Agreement.

Subject to the provisions of Article 2.3, this Agreement shall remain in effect for a period of ~~ten~~twenty (~~10~~ 20) years from the Effective Date ~~or such other longer period as the Developer may request (Term to be Specified in Individual Agreements)~~ and shall be automatically renewed for each successive one-year period thereafter.

2.3 Termination.

2.3.1 Written Notice.

This Agreement may be terminated by ~~the Developer~~NYSEG or TrAILCo after giving the ~~NYISO and Connecting Transmission Owner~~non-terminating Parties ninety (90) Calendar Days advance written notice, or by the ~~NYISO and Connecting Transmission Owner~~Parties notifying FERC after the ~~Large Generating Facility is Retired~~Mainesburg Substation permanently ceases commercial operation.

2.3.2 Default.

Any Party may terminate this Agreement in accordance with Article 17.

2.3.3 Compliance.

Notwithstanding Articles 2.3.1 and 2.3.2, no termination of this Agreement shall become effective until the Parties have complied with all Applicable Laws and Regulations applicable to such termination, including the filing with FERC of a notice of termination of this Agreement, which notice has been accepted for filing by FERC.

2.4 Termination Costs.

If a Party elects to terminate this Agreement pursuant to Article 2.3.1 above, the terminating Party shall pay all costs incurred (including any cancellation costs relating to orders or contracts for ~~Attachment~~System Upgrade Facilities and equipment) or charges assessed by the other Parties, as of the date of the other Parties' receipt of such notice of termination, that are the responsibility of the terminating Party under this Agreement. In the event of termination by a Party, all Parties shall use commercially Reasonable Efforts to mitigate the costs, damages and charges arising as a consequence of termination. Upon termination of this Agreement, unless otherwise ordered or approved by FERC:

2.4.1 With respect to any portion of the ~~Connecting Transmission Owner's~~ ~~Attachment~~System Upgrade Facilities owned by TrAILCo that have not yet been constructed or installed, ~~the Connecting Transmission Owner~~TrAILCo shall, to the extent possible ~~and with Developer's authorization,~~ cancel any pending orders of, or return, any materials or equipment for, or contracts for construction of, such facilities; ~~provided that in the event Developer elects not to authorize such cancellation, Developer shall assume all payment obligations with respect to such materials, equipment, and contracts, and the Connecting Transmission Owner shall deliver such material and equipment, and, if necessary, assign such contracts, to Developer as soon as practicable, at Developer's expense. To the extent that Developer has already paid Connecting Transmission Owner for any or all such costs of materials or equipment not taken by Developer, Connecting Transmission Owner shall promptly refund such amounts to Developer, less any costs, including penalties incurred by the Connecting Transmission Owner to,~~ With respect to any portion of the System Upgrade Facilities owned by NYSEG that have not yet been

constructed or installed, NYSEG shall, to the extent possible, cancel any pending orders of, or return such, any materials, or equipment for, or contracts for construction of, such facilities.

~~If Developer terminates this Agreement, it shall be responsible for all costs incurred in association with Developer's interconnection, including any cancellation costs relating to orders or contracts for Attachment Facilities and equipment, and other expenses including any System Upgrade Facilities and System Deliverability Upgrades for which the Connecting Transmission Owner has incurred expenses and has not been reimbursed by the Developer.~~

~~1.1.1—Connecting Transmission Owner may, at its option, retain any portion of such materials, equipment, or facilities that Developer chooses not to accept delivery of, in which case Connecting Transmission Owner shall be responsible for all costs associated with procuring such materials, equipment, or facilities.~~

2.4.2 With respect to any portion of the ~~Attachment~~System Upgrade Facilities, and any other facilities already installed or constructed pursuant to the terms of this Agreement, ~~Developer~~and unless said termination is due to NYSEG's Default under Article 17, TrAILCo shall be responsible for all costs associated with the removal, relocation or other disposition or retirement of such materials, equipment, or facilities, where applicable.

2.5 Disconnection.

Upon termination of this Agreement, ~~Developer and Connecting Transmission Owner~~NYSEG and TrAILCo will take all appropriate steps to disconnect the ~~Developer's Large Generating Facility from the New York State Transmission System~~Mainesburg Substation from the Watercure Line and to return the Watercure Line to its configuration prior to the interconnection described herein. All costs required to effectuate such disconnection and return of the Watercure Line shall be borne by ~~the terminating Party~~TrAILCo, unless such termination resulted from ~~the non-terminating Party~~NYSEG's Default of this Agreement ~~or such non-terminating Party otherwise is responsible for these costs under this Agreement.~~

2.6 Survival.

This Agreement shall continue in effect after termination to the extent necessary to provide for final billings and payments and for costs incurred hereunder; including billings and payments pursuant to this Agreement; to permit the determination and enforcement of liability and indemnification obligations arising from acts or events that occurred while this Agreement was in effect; and to permit ~~Developer and Connecting Transmission Owner~~ NYSEG and TrAILCo each to have access to the lands of the other pursuant to this Agreement or other applicable agreements, to disconnect, remove or salvage its own facilities and equipment.

ARTICLE 3. REGULATORY FILINGS

3.1 Filing.

NYISO ~~and Connecting Transmission Owner~~, TrAILCo and NYSEG shall file this Agreement (and any amendment hereto) with the appropriate Governmental Authority, if required. Any information related to studies for interconnection asserted by ~~Developer~~ NYSEG or TrAILCo to contain Confidential Information shall be treated in accordance with Article 22 of this Agreement and Attachment F to the NYISO OATT. ~~If the Developer has executed this Agreement, or any amendment thereto, the Developer~~ NYSEG and TrAILCo shall reasonably cooperate with NYISO and ~~Connecting Transmission Owner~~ one another with respect to such filing and ~~to~~ shall provide any information reasonably requested by ~~NYISO and Connecting Transmission Owner~~ the other Party needed to comply with Applicable Laws and Regulations.

ARTICLE 4. SCOPE OF INTERCONNECTION SERVICE

4.1 Provision of Service.

~~NYISO will provide Developer with interconnection service of the following type for the term of this Agreement.~~

NYSEG shall permit TrAILCo to interconnect the Mainesburg Substation to the Watercure Line in accordance with the terms and conditions of this Agreement.

~~1.1.2 Product.~~

~~NYISO will provide [] Interconnection Service to Developer at the Point of Interconnection.~~

~~1.1.3 Developer is responsible for ensuring that its actual Large Generating Facility output matches the scheduled delivery from the Large Generating Facility to the New York State Transmission System, consistent with the scheduling requirements of the NYISO's FERC-approved market structure, including ramping into and out of such scheduled delivery, as measured at the Point of Interconnection, consistent with the scheduling requirements of the NYISO OATT and any applicable FERC approved market structure.~~

4.2 No Transmission Delivery Service.

The execution of this Agreement does not constitute a request for, nor agreement to provide, any Transmission Service under the NYISO OATT, and does not convey any right to deliver electricity to any specific customer or Point of Delivery. ~~If Developer wishes to obtain Transmission Service on the New York State Transmission System, then Developer must request such Transmission Service in accordance with the provisions of the NYISO OATT.~~

ARTICLE 5. SYSTEM UPGRADE FACILITIES ENGINEERING, PROCUREMENT, AND CONSTRUCTION

~~1.2 No Other Services.~~

~~The execution of this Agreement does not constitute a request for, nor agreement to provide Energy, any Ancillary Services or Installed Capacity under the NYISO Market Administration and Control Area Services Tariff ("Services Tariff"). If Developer wishes to supply Energy, Installed Capacity or Ancillary Services, then Developer will make application to do so in accordance with the NYISO Services Tariff.~~

**Article 2. — INTERCONNECTION FACILITIES ENGINEERING, —
— PROCUREMENT, AND CONSTRUCTION**

4.3.5.1 Options Construction Dates/Description of Facilities.

~~Unless otherwise mutually agreed to by Developer and Connecting Transmission Owner, Developer shall select the In-Service Date, Initial Synchronization Date, and Commercial Operation Date; and either Standard Option or Alternate Option set forth below for completion of the Connecting Transmission Owner's Attachment Facilities and System Upgrade Facilities and System Deliverability Upgrades as set forth in Appendix A hereto, and such dates and selected option shall be set forth in Appendix B hereto.~~

NYSEG, in consultation with TrAILCo, shall select the Outage Start Date. NYSEG and TrAILCo shall mutually select the Initial Energization Date and the Commercial Operation Date for completion of the System Upgrade Facilities set forth in Appendix A hereto, including Stand Alone System Upgrade Facilities, and such dates shall be set forth in Appendix B hereto.

4.3.15.1.1 ~~Standard Option~~ Construction of System Upgrade Facilities.

~~The Connecting Transmission Owner~~TrAILCo and NYSEG shall design, procure, ~~and~~ construct ~~the Connecting Transmission Owner's Attachment Facilities and~~and install the System Upgrade Facilities ~~and System Deliverability Upgrades~~, using Reasonable Efforts (unless Appendix C of this Agreement requires a superior level of effort) to complete the ~~Connecting Transmission Owner's Attachment Facilities and~~ System Upgrade Facilities ~~and System Deliverability Upgrades~~in accordance with Appendices A and C, and by the dates set forth in Appendix B hereto. ~~The Connecting Transmission Owner shall not~~Certain System Upgrade Facilities, as set forth in Appendix A hereto, shall be constructed by TrAILCo but shall be owned, operated, maintained, tested, repaired and replaced by NYSEG. Neither NYSEG nor TrAILCo shall be required to undertake any action which is inconsistent with its standard safety practices, its material and equipment specifications, its design criteria and construction procedures, its labor agreements, and Applicable Laws and Regulations. In the event ~~the~~

~~Connecting Transmission Owner~~ either NYSEG or TrAILCo reasonably expects that it will not be able to complete the ~~Connecting Transmission Owner's Attachment Facilities and System Upgrade Facilities and System Deliverability Upgrades~~ by the specified dates, ~~the Connecting Transmission Owner~~ that Party shall promptly provide written notice to the ~~Developer~~ other Party, and to the NYISO, and shall undertake Reasonable Efforts (unless Appendix C of this Agreement requires a superior level of effort) to meet the earliest dates thereafter.

~~2.1.1~~ — ~~Alternate Option.~~

~~If the dates designated by Developer are acceptable to Connecting Transmission Owner, the Connecting Transmission Owner shall so notify Developer and NYISO within thirty (30) Calendar Days, and shall assume responsibility for the design, procurement and construction of the Connecting Transmission Owner's Attachment Facilities by the designated dates. If Connecting Transmission Owner subsequently fails to complete Connecting Transmission Owner's Attachment Facilities by the In-Service Date, to the extent necessary to provide back-feed power; or fails to complete System Upgrade Facilities or System Deliverability Upgrades by the Initial Synchronization Date to the extent necessary to allow for Trial Operation at full power output, unless other arrangements are made by the Developer and Connecting Transmission Owner for such Trial Operation; or fails to complete the System Upgrade Facilities and System Deliverability Upgrades by the Commercial Operation Date, as such dates are reflected in Appendix B hereto; Connecting Transmission Owner shall pay Developer liquidated damages in accordance with Article 5.3, Liquidated Damages, provided, however, the dates designated by Developer shall be extended day for day for each day that NYISO refuses to grant clearances to install equipment.~~

~~2.1.2~~ — ~~Option to Build.~~

~~If the dates designated by Developer are not acceptable to Connecting Transmission Owner, the Connecting Transmission Owner shall so notify the Developer and NYISO within thirty (30) Calendar Days, and unless the Developer and Connecting Transmission Owner agree otherwise, Developer shall have the option to assume responsibility for the design, procurement and construction of Connecting Transmission Owner's Attachment Facilities and Stand Alone System Upgrade Facilities on the dates specified in Article 5.1.2; provided that if an Attachment Facility or Stand Alone System Upgrade Facility is needed for more than one Developer's project, Developer's option to build such Facility shall be contingent on the agreement of all other affected Developers. NYISO, Connecting Transmission Owner and Developer must agree as to what constitutes Stand Alone System Upgrade Facilities and identify such Stand Alone System Upgrade Facilities in Appendix A hereto. Except for Stand Alone System Upgrade~~

Facilities, Developer shall have no right to construct System Upgrade Facilities under this option.

~~2.1.3 — Negotiated Option.~~

~~If the Developer elects not to exercise its option under Article 5.1.3, Option to Build, Developer shall so notify Connecting Transmission Owner and NYISO within thirty (30) Calendar Days, and the Developer and Connecting Transmission Owner shall in good faith attempt to negotiate terms and conditions (including revision of the specified dates and liquidated damages, the provision of incentives or the procurement and construction of a portion of the Connecting Transmission Owner's Attachment Facilities and Stand Alone System Upgrade Facilities by Developer) pursuant to which Connecting Transmission Owner is responsible for the design, procurement and construction of the Connecting Transmission Owner's Attachment Facilities and System Upgrade Facilities and System Deliverability Upgrades. If the two Parties are unable to reach agreement on such terms and conditions, Connecting Transmission Owner shall assume responsibility for the design, procurement and construction of the Connecting Transmission Owner's Attachment Facilities and System Upgrade Facilities and System Deliverability Upgrades pursuant to 5.1.1, Standard Option.~~

~~2.2 — General Conditions Applicable to Option to Build.~~

~~If Developer assumes responsibility for the design, procurement and construction of the Connecting Transmission Owner's Attachment Facilities and Stand Alone System Upgrade Facilities;~~

~~(1) — Developer shall engineer, procure equipment, and construct the Connecting Transmission Owner's Attachment Facilities and Stand Alone System Upgrade Facilities (or portions thereof) using Good Utility Practice and using standards and specifications provided in advance by the Connecting Transmission Owner;~~

~~(2) — Developer's engineering, procurement and construction of the Connecting Transmission Owner's Attachment Facilities and Stand Alone System Upgrade Facilities shall comply with all requirements of law to which Connecting Transmission Owner would be subject in the engineering, procurement or construction of the Connecting Transmission Owner's Attachment Facilities and Stand Alone System Upgrade Facilities;~~

~~(3) — Connecting Transmission Owner shall review and approve the engineering design, equipment acceptance tests, and the construction of the Connecting Transmission Owner's Attachment Facilities and Stand Alone System Upgrade Facilities;~~

~~(4) — Prior to commencement of construction, Developer shall provide to Connecting Transmission Owner and NYISO a schedule for construction of the Connecting Transmission Owner's Attachment Facilities and Stand Alone System Upgrade Facilities, and shall promptly respond to requests for information from Connecting Transmission Owner or NYISO;~~

~~(5) — At any time during construction, Connecting Transmission Owner shall have the right to gain unrestricted access to the Connecting Transmission Owner's Attachment Facilities and Stand Alone System Upgrade Facilities and to conduct inspections of the same;~~

~~(6) — At any time during construction, should any phase of the engineering, equipment procurement, or construction of the Connecting Transmission Owner's Attachment Facilities and Stand Alone System Upgrade Facilities not meet the standards and specifications provided by-~~

~~Connecting Transmission Owner, the Developer shall be obligated to remedy deficiencies in that portion of the Connecting Transmission Owner's Attachment Facilities and Stand Alone System Upgrade Facilities;~~

~~(7) — Developer shall indemnify Connecting Transmission Owner and NYISO for claims arising from the Developer's construction of Connecting Transmission Owner's Attachment Facilities and Stand Alone System Upgrade Facilities under procedures applicable to Article 18.1 Indemnity;~~

~~(8) — Developer shall transfer control of Connecting Transmission Owner's Attachment Facilities and Stand Alone System Upgrade Facilities to the Connecting Transmission Owner;~~

~~(9) — Unless the Developer and Connecting Transmission Owner otherwise agree, Developer shall transfer ownership of Connecting Transmission Owner's Attachment Facilities and Stand Alone System Upgrade Facilities to Connecting Transmission Owner;~~

~~(10) — Connecting Transmission Owner shall approve and accept for operation and maintenance the Connecting Transmission Owner's Attachment Facilities and Stand Alone System Upgrade Facilities to the extent engineered, procured, and constructed in accordance with this Article 5.2; and~~

~~(11) — Developer shall deliver to NYISO and Connecting Transmission Owner "as built" drawings, information, and any other documents that are reasonably required by NYISO or Connecting Transmission Owner to assure that the Attachment Facilities and Stand Alone System Upgrade Facilities are built to the standards and specifications required by Connecting Transmission Owner.~~

~~2.3 — Liquidated Damages.~~

~~The actual damages to the Developer, in the event the Connecting Transmission Owner's Attachment Facilities or System Upgrade Facilities or System Deliverability Upgrades are not completed by the dates designated by the Developer and accepted by the Connecting Transmission Owner pursuant to subparagraphs 5.1.2 or 5.1.4, above, may include Developer's fixed operation and maintenance costs and lost opportunity costs. Such actual damages are uncertain and impossible to determine at this time. Because of such uncertainty, any liquidated damages paid by the Connecting Transmission Owner to the Developer in the event that Connecting Transmission Owner does not complete any portion of the Connecting Transmission Owner's Attachment Facilities, System Upgrade Facilities or System Deliverability Upgrades by the applicable dates, shall be an amount equal to 1/2 of 1 percent per day of the actual cost of the Connecting Transmission Owner's Attachment Facilities and System Upgrade Facilities and System Deliverability Upgrades, in the aggregate, for which Connecting Transmission Owner has assumed responsibility to design, procure and construct.~~

~~However, in no event shall the total liquidated damages exceed 20 percent of the actual cost of the Connecting Transmission Owner Attachment Facilities and System Upgrade Facilities and System Deliverability Upgrades for which the Connecting Transmission Owner has assumed responsibility to design, procure, and construct. The foregoing payments will be made by the Connecting Transmission Owner to the Developer as just compensation for the damages caused to the Developer, which actual damages are uncertain and impossible to determine at this time, and as reasonable liquidated damages, but not as a penalty or a method to secure performance of this Agreement. Liquidated damages, when the Developer and Connecting Transmission Owner~~

~~agree to them, are the exclusive remedy for the Connecting Transmission Owner's failure to meet its schedule.~~

~~Further, Connecting Transmission Owner shall not pay liquidated damages to Developer if: (1) Developer is not ready to commence use of the Connecting Transmission Owner's Attachment Facilities or System Upgrade Facilities or System Deliverability Upgrades to take the delivery of power for the Developer's Large Generating Facility's Trial Operation or to export power from the Developer's Large Generating Facility on the specified dates, unless the Developer would have been able to commence use of the Connecting Transmission Owner's Attachment Facilities or System Upgrade Facilities or System Deliverability Upgrades to take the delivery of power for Developer's Large Generating Facility's Trial Operation or to export power from the Developer's Large Generating Facility, but for Connecting Transmission Owner's delay; (2) the Connecting Transmission Owner's failure to meet the specified dates is the result of the action or inaction of the Developer or any other Developer who has entered into a Standard Large Generator Interconnection Agreement with the Connecting Transmission Owner and NYISO, or action or inaction by any other Party, or any other cause beyond Connecting Transmission Owner's reasonable control or reasonable ability to cure; (3) the Developer has assumed responsibility for the design, procurement and construction of the Connecting Transmission Owner's Attachment Facilities and Stand Alone System Upgrade Facilities; or (4) the Connecting Transmission Owner and Developer have otherwise agreed. In no event shall NYISO have any liability whatever to Developer for liquidated damages associated with the engineering, procurement or construction of Attachment Facilities or System Upgrade Facilities or System Deliverability Upgrades.~~

~~2.4~~ **Power System Stabilizers.**

~~The Developer shall procure, install, maintain and operate Power System Stabilizers in accordance with the requirements identified in the Interconnection Studies conducted for Developer's Large Generating Facility. NYISO and Connecting Transmission Owner reserve the right to reasonably establish minimum acceptable settings for any installed Power System Stabilizers, subject to the design and operating limitations of the Large Generating Facility. If the Large Generating Facility's Power System Stabilizers are removed from service or not capable of automatic operation, the Developer shall immediately notify the Connecting Transmission Owner and NYISO. The requirements of this paragraph shall not apply to wind generators.~~

4.45.2 Equipment Procurement.

If responsibility for construction of the ~~Connecting Transmission Owner's Attachment Facilities or System Upgrade Facilities or System Deliverability Upgrades~~ is to be borne by the ~~Connecting Transmission Owner~~, then the ~~Connecting Transmission Owner~~ TrAILCo, then TrAILCo shall commence the design of the ~~Connecting Transmission Owner's Attachment Facilities or System Upgrade Facilities or System Deliverability Upgrades~~, and procure

necessary equipment, as soon as practicable after all of the following conditions are satisfied, unless ~~the Developer and Connecting Transmission Owner~~ NYSEG and TrAILCo otherwise agree in writing:

~~2.4.1~~ 2.4.1—~~NYISO and Connecting Transmission Owner have completed the Interconnection Facilities Study pursuant to the Interconnection Facilities Study Agreement;~~

~~2.4.2~~ 2.4.2—~~The NYISO has completed the required cost allocation analyses, and Developer has accepted his share of the costs for necessary System Upgrade Facilities and System Deliverability Upgrades in accordance with the provisions of Attachment S of the NYISO OATT;~~

~~4.4.15.2.1~~ 4.4.15.2.1 ~~The Connecting Transmission Owner~~ TrAILCo has received written authorization to proceed with design and procurement from ~~the Developer~~ NYSEG by the date specified in Appendix B hereto; ~~and~~.

~~4.4.25.2.2~~ 4.4.25.2.2 ~~The Developer~~ TrAILCo has provided security to ~~the Connecting Transmission Owner~~ NYSEG in accordance with ~~Article 11.5 by the dates specified in~~ Appendix BC hereto.

4.5.3 **Construction Commencement.**

~~The Connecting Transmission Owner~~ TrAILCo shall commence construction of the ~~Connecting Transmission Owner's Attachment Facilities and~~ System Upgrade Facilities ~~and System Deliverability Upgrades~~ for which it is responsible as soon as practicable after the following additional conditions are satisfied:

~~4.5.15.3.1~~ 4.5.15.3.1 Approval of the appropriate Governmental Authority has been obtained for any facilities requiring regulatory approval;

~~4.5.25.3.2~~ 4.5.25.3.2 Necessary real property rights and rights-of-way have been obtained, to the extent required for the construction of ~~a discrete aspect of the Connecting Transmission~~

~~Owner's Attachment Facilities and~~the System Upgrade Facilities ~~and System Deliverability Upgrades;~~

~~4.5.35.3.3~~ The Connecting Transmission Owner TrAILCo has received written authorization to proceed with construction from ~~the Developer by the date specified in Appendix B hereto~~NYSEG; and

~~4.5.45.3.4~~ The Developer TrAILCo has provided security to ~~the Connecting Transmission Owner~~NYSEG in accordance with ~~Article 11.5 by the dates specified in~~ Appendix ~~B~~C hereto.

~~4.6~~5.4 **Work Progress.**

~~The Developer and Connecting Transmission Owner~~NYSEG and TrAILCo will keep each other, and NYISO, advised periodically as to the progress of their respective design, procurement and construction efforts. Any Party may, at any time, request a progress report from ~~the Developer or Connecting Transmission Owner~~TrAILCo or NYSEG. If, at any time, ~~the Developer~~NYSEG determines that the completion of the ~~Connecting Transmission Owner's Attachment~~System Upgrade Facilities will not be required until after the specified ~~In-Service~~Commercial Operation Date, ~~the Developer~~NYSEG will provide written notice to ~~the Connecting Transmission Owner and NYISO~~TrAILCo of such later date upon which the completion of the ~~Connecting Transmission Owner's Attachment~~System Upgrade Facilities will be required.

~~4.7~~5.5 **Information Exchange.**

As soon as reasonably practicable after the Effective Date, ~~the Developer and Connecting Transmission Owner~~NYSEG and TrAILCo shall exchange information, and provide NYISO the

same information, regarding the design and compatibility of their respective ~~Attachment~~System Upgrade Facilities, and ~~the~~ compatibility of ~~the Attachment~~their respective System Upgrade Facilities, with the New York State Transmission System and PJM Transmission System, and shall work diligently and in good faith to make any necessary design changes.

~~4.8.5.6~~ Limited Operation System Upgrade Facilities.

~~If any of the Connecting Transmission Owner's Attachment Facilities or System Upgrade Facilities or System Deliverability Upgrades are not reasonably expected to be completed prior to the Commercial Operation Date of the Developer's Large Generating Facility, NYISO shall, upon the request and at the expense of Developer, in conjunction with the Connecting Transmission Owner, perform operating studies on a timely basis to determine the extent to which the Developer's Large Generating Facility and the Developer's Attachment Facilities may operate prior to the completion of the Connecting Transmission Owner's Attachment Facilities or System Upgrade Facilities or System Deliverability Upgrades consistent with Applicable Laws and Regulations, Applicable Reliability Standards, Good Utility Practice, and this Agreement. Connecting Transmission Owner and NYISO shall permit Developer to operate the Developer's Large Generating Facility and the Developer's Attachment Facilities in accordance with the results of such studies.~~

~~2.5~~ Developer's Attachment Facilities ("DAF").

~~Developer~~ TRAILCo and NYSEG shall, ~~at its expense,~~ design, procure, construct, ~~own and~~ install ~~the DAF, as set forth in~~ and own the System Upgrade Facilities in accordance with Appendix A ~~hereto~~ and the following.

~~4.8.15.6.1~~ DAF Specifications For System Upgrade Facilities.

~~Developer shall submit initial specifications for the DAF, including System Protection Facilities, to Connecting Transmission Owner and NYISO at least one hundred eighty (180) Calendar Days prior to the Initial Synchronization Date; and final specifications for review and comment at least ninety (90) Calendar Days prior to the Initial Synchronization Date. Connecting Transmission Owner and NYISO shall review such specifications to ensure that the DAF are compatible with the technical specifications, operational control, and safety requirements of the Connecting Transmission Owner and NYISO and comment on such specifications within thirty (30) Calendar Days of Developer's submission. All specifications provided hereunder shall be deemed to be Confidential Information.~~

The specifications for System Upgrade Facilities, including System Protection Facilities, are set forth in Appendix A.

4.8.25.6.2 No Warranty.

The review by TrAILCo of NYSEG’s final specifications for System Upgrade Facilities to be constructed or installed by NYSEG shall not be construed as confirming, endorsing, or providing a warranty as to the design, fitness, safety, durability or reliability of those System Upgrade Facilities. NYSEG shall make such changes to those System Upgrade Facilities as may reasonably be required by TrAILCo in accordance with Good Utility Practice.

The review by NYSEG of ~~Developer~~TrAILCo’s final specifications ~~by Connecting-Transmission Owner and NYISO~~for System Upgrade Facilities to be constructed or installed by TrAILCo shall not be construed as confirming, endorsing, or providing a warranty as to the design, fitness, safety, durability or reliability of ~~the Large Generating Facility, or the DAF.~~
~~Developer~~those System Upgrade Facilities. TrAILCo shall make such changes to ~~the DAF~~those System Upgrade Facilities as may reasonably be required by ~~Connecting-Transmission Owner or NYISO,~~NYSEG in accordance with Good Utility Practice, ~~to ensure that the DAF are compatible with the technical specifications, operational control, and safety requirements of the Connecting-Transmission Owner and NYISO.~~

4.8.35.6.3 ~~DAF~~Design and Construction.

The ~~DAF~~System Upgrade Facilities shall be designed and constructed in accordance with Good Utility Practice. Within one hundred twenty (120) Calendar Days after the Commercial Operation Date, unless ~~the Developer and Connecting-Transmission Owner~~NYSEG and TrAILCo agree on another mutually acceptable deadline, ~~the Developer~~ TrAILCo shall deliver to ~~the Connecting-Transmission Owner and NYISO~~ “as-built NYSEG “as-built” drawings, information and documents for the ~~DAF~~System Upgrade Facilities, such as: a one-line diagram,

a site plan showing the ~~Large Generating Facility and the DAF~~Watercure Line (as segmented) and the System Upgrade Facilities, plan and elevation drawings showing the layout of the ~~DAF~~System Upgrade Facilities, a relay functional diagram, relaying AC and DC schematic wiring diagrams and relay settings for all facilities associated with ~~the Developer~~TrAILCo's ~~step-up~~step-down transformers, the facilities connecting the ~~Large Generating Facility~~Watercure Line to the ~~step-up~~step-down transformers and the ~~DAF~~System Upgrade Facilities, and the impedances (determined by factory tests) for the associated ~~step-up~~step-down transformers and the ~~Large Generating Facility. The Developer~~Watercure Line. NYSEG shall provide to TrAILCo, and coordinate with ~~Connecting Transmission Owner and NYISO~~ TrAILCo, with respect to proposed specifications for the ~~excitation system, automatic voltage regulator, Large Generating Facility~~Watercure Line control and protection settings, transformer tap settings, and communications, if applicable.

~~2.6~~ NYSEG and TrAILCo shall confer with the NYISO and PJM regarding the Connecting Transmission Owner's Attachment Facilities Construction.

~~The Connecting Transmission Owner's Attachment Facilities shall be designed and constructed in accordance with Good Utility Practice. Upon request, within one hundred twenty (120) Calendar Days after the Commercial Operation Date, unless the Connecting Transmission Owner and Developer agree on another mutually acceptable deadline, the Connecting Transmission Owner shall deliver to the Developer "as built" drawings, relay diagrams, information and documents for the Connecting Transmission Owner's Attachment Facilities set forth in Appendix A.~~

~~The Connecting Transmission Owner shall~~ transfer of operational control of the ~~Connecting Transmission Owner's Attachment Facilities and Stand Alone~~ System Upgrade Facilities to the NYISO, or PJM, as applicable, upon completion of such facilities.

5.7 [Reserved]

~~4.9~~5.8 **Access Rights.**

~~4.9.15.8.1~~ NYSEG's Access. Upon reasonable notice and supervision by the ~~Granting Party,~~TrAILCo, TrAILCo hereby authorizes the authorized agents, representatives, contractors, and employees of NYSEG to enter the facilities of TrAILCo at all reasonable times and subject to any required or necessary regulatory approvals, ~~either the Connecting Transmission Owner or Developer ("Granting Party")~~ shall furnish to ~~the other of those two Parties ("Access Party")~~NYSEG at no cost any rights of use, licenses, rights of way and

easements with respect to lands owned or controlled by ~~the Granting Party, its agents (if allowed under the applicable agency agreement), or any Affiliate, that are necessary to enable the Access Party~~ TrAILCo to the extent reasonably required for NYSEG to obtain ingress and egress at the Point of Interconnection to ~~construct,~~ operate, maintain, repair, test (or witness testing), inspect, replace or remove facilities and equipment to: (i) interconnect the ~~Large Generating Facility with the New York State Transmission System~~ Mainesburg Substation to the Watercure Line; (ii) operate and maintain the ~~Large Generating Facility, the Attachment~~ Watercure Line, the System Upgrade Facilities owned by NYSEG, and the New York State Transmission System; and (iii) disconnect or remove ~~the Access Party~~ NYSEG's facilities and equipment upon termination of this Agreement. ~~In exercising such licenses, rights of way and easements, the Access Party shall not unreasonably disrupt or interfere with normal operation of the Granting Party's business and shall adhere to the safety rules and procedures established in advance, as may be changed from time to time, by the Granting Party and provided to the Access Party. The Access Party shall indemnify the Granting Party against all claims of injury or damage from third parties resulting from the exercise of the access rights provided for herein.~~ TrAILCo's obligation hereunder shall be to provide NYSEG (and its agents, representatives, contractors and employees) adequate and continuous access to all sites where access is authorized under this Article 5.8. NYSEG and its authorized agents, representatives, contractors and employees, shall comply with TrAILCo's safety and security procedures, switching and tagging rules, and escort and other applicable access requirements, including NERC CIP requirements, in connection with exercising the rights of access granted hereby. TrAILCo shall give prompt notice to NYSEG of any changes to TrAILCo's safety and security procedures, switching and tagging rules, and escort and other

applicable access requirements.

NYSEG must, prior to any access to TrAILCo's facilities, and during the term of this Agreement, provide and maintain insurance in the kinds and amounts referred in Article 18.

TrAILCo reserves the right to deny access to NYSEG's authorized agents, representatives, contractors and employees, in or around TrAILCo's facilities if, in TrAILCo's sole judgment, such authorized agents, representatives, contractors and employees are:

(a) bringing, using, distributing, selling or possessing illegal drugs or alcoholic beverages at the TrAILCo's facilities;

(b) unfit for duty at any time during their assignment and under the influence of alcohol or other drugs; or

(c) otherwise engaged in any improper or unlawful activity.

Furthermore, TrAILCo shall have the authority to suspend NYSEG's access, work or operations (including access, work or operations of any of NYSEG's agents, representatives, contractors and employees) in and around such TrAILCo facilities if, in its sole judgment, at any time hazardous conditions arise or any unsafe practices are being followed by NYSEG's agents, representatives, contractors and employees and NYSEG fails to take immediate measures to correct such conditions or practices. In exercising its access rights under this Article 5.8.1, NYSEG shall not unreasonably disrupt or interfere with normal operation of TrAILCo's business and shall adhere to the safety rules and procedures established in advance, as may be changed

from time to time, by TrAILCo and provided to NYSEG. In accordance with Article 18, NYSEG shall indemnify TrAILCo against all claims of injury or damage from third parties resulting from the exercise of the access rights provided for herein.

5.8.2 TrAILCo's Access. Upon reasonable notice and supervision by NYSEG, NYSEG hereby authorizes the authorized agents, representatives, contractors, and employees of TrAILCo to enter the facilities of NYSEG at all reasonable times and subject to any required or necessary regulatory approvals, shall furnish to TrAILCo at no cost any rights of use, licenses, rights of way and easements with respect to lands owned or controlled by NYSEG to the extent reasonably required for TrAILCo to obtain ingress and egress at the Point of Interconnection to construct, operate, maintain, repair, test (or witness testing), inspect, replace or remove facilities and equipment to: (i) interconnect the Mainesburg Substation to the Watercure Line; (ii) operate and maintain the Mainesburg Substation, the System Upgrade Facilities owned by TrAILCo, and the PJM Transmission System; and (iii) disconnect or remove the TrAILCo's facilities and equipment upon termination of this Agreement and return the Watercure Line to its pre-interconnection configuration. NYSEG's obligation hereunder shall be to provide TrAILCo (and its agents, representatives, contractors and employees) adequate and continuous access to all sites where access is authorized under this Section 5.8. TrAILCo and its authorized agents, representatives, contractors and employees, shall comply with NYSEG's safety and security procedures, switching and tagging rules, and escort and other applicable access requirements in connection with exercising the rights of access granted hereby. NYSEG shall give prompt notice to TrAILCo of any changes to NYSEG's safety and security procedures, switching and tagging rules, and escort and other applicable access requirements.

TrAILCo must, prior to any access to NYSEG's facilities, and during the term of this Agreement, provide and maintain insurance in the kinds and amounts referred in Article 18 hereof.

NYSEG reserves the right to deny access to TrAILCo's authorized agents, representatives, contractors and employees, in or around the NYSEG's facilities if, in NYSEG's sole judgment, such authorized agents, representatives, contractors and employees are:

(a) bringing, using, distributing, selling or possessing illegal drugs or alcoholic beverages at the NYSEG's facilities;

(b) unfit for duty at any time during their assignment and under the influence of alcohol or other drugs; or

(c) otherwise engaged in any improper or unlawful activity.

Furthermore, NYSEG shall have the authority to suspend TrAILCo's access, work or operations (including access, work or operations of any of TrAILCo's agents, representatives, contractors and employees) in and around such NYSEG facilities if, in its sole judgment, at any time hazardous conditions arise or any unsafe practices are being followed by TrAILCo's agents, representatives, contractors and employees and TrAILCo fails to take immediate measures to correct such conditions or practices. In exercising its access rights under this Article 5.8.2, TrAILCo shall not unreasonably disrupt or interfere with normal operation of NYSEG's business and shall adhere to the safety rules and procedures established in advance, as may be changed from time to time, by NYSEG and provided to TrAILCo. In accordance with Article 18, TrAILCo shall indemnify NYSEG against all claims of injury or damage from third parties resulting from the exercise of the access rights provided for herein.

4.105.9 Lands of Other Property Owners.

If any part of the ~~Connecting Transmission Owner's Attachment Facilities and/or System Upgrade Facilities and/or System Deliverability Upgrades~~ is to be installed on or adjacent to property owned by persons other than ~~Developer or Connecting Transmission Owner, the Connecting Transmission Owner shall at Developer's~~ NYSEG or TrAILCo, TrAILCo shall at its own expense use efforts, similar in nature and extent to those that it typically undertakes for its own or affiliated ~~generation~~ transmission, including use of its eminent domain authority, and to the extent consistent with state law, to procure from such persons any rights of use, licenses, rights of way and easements that are necessary to construct, operate, maintain, test, inspect, replace or remove the ~~Connecting Transmission Owner's Attachment Facilities and/or System Upgrade Facilities and/or System Deliverability Upgrades~~ upon such property. NYSEG shall cooperate with TrAILCo's efforts under this Article 5.9.

4.115.10 Permits.

~~NYISO, Connecting Transmission Owner and the Developer~~ TrAILCo and NYSEG shall cooperate with each other in good faith in obtaining all permits, licenses and authorizations that are necessary to accomplish the interconnection in compliance with Applicable Laws and Regulations. With respect to this paragraph, ~~Connecting Transmission Owner~~ TrAILCo shall provide permitting assistance to ~~the Developer~~ NYSEG comparable to that provided to ~~the Connecting Transmission Owner~~ TrAILCo's own, or an Affiliate's, generation, ~~if any. or~~ transmission facilities, if any, provided that NYSEG shall pay TrAILCo's costs in providing such permitting assistance. With respect to this paragraph, NYSEG shall provide permitting assistance to TrAILCo comparable to that provided to NYSEG's own, or an Affiliate's,

generation or transmission facilities, if any, provided that TrAILCo shall pay NYSEG's costs in providing such permitting assistance.

5.11 Tax Status; Non-Jurisdictional Entities.

~~2.7 Early Construction of Base-Case Facilities.~~

~~Developer may request Connecting Transmission Owner to construct, and Connecting Transmission Owner shall construct, subject to a binding cost allocation agreement reached in accordance with Attachment S to the NYISO OATT, including Section 25.8.7 thereof, using Reasonable Efforts to accommodate Developer's In-Service Date, all or any portion of any System Upgrade Facilities or System Deliverability Upgrades required for Developer to be interconnected to the New York State Transmission System which are included in the Base Case of the Class Year Interconnection Facilities Study for the Developer, and which also are required to be constructed for another Developer, but where such construction is not scheduled to be completed in time to achieve Developer's In-Service Date.~~

~~4.11.15.11.1 Suspension~~ Tax Status.

~~Developer reserves the right, upon written notice to Connecting Transmission Owner and NYISO, to suspend at any time all work by Connecting Transmission Owner associated with the construction and installation of Connecting Transmission Owner's Attachment Facilities and/or System Upgrade Facilities and/or System Deliverability Upgrades required for only that Developer under this Agreement with the condition that the New York State Transmission System shall be left in a safe and reliable condition in accordance with Good Utility Practice and the safety and reliability criteria of Connecting Transmission Owner and NYISO. In such event, Developer shall be responsible for all reasonable and necessary costs and/or obligations in accordance with Attachment S to the NYISO OATT including those which Connecting Transmission Owner (i) has incurred pursuant to this Agreement prior to the suspension and (ii) incurs in suspending such work, including any costs incurred to perform such work as may be necessary to ensure the safety of persons and property and the integrity of the New York State Transmission System during such suspension and, if applicable, any costs incurred in connection with the cancellation or suspension of material, equipment and labor contracts which Connecting Transmission Owner cannot reasonably avoid; provided, however, that prior to canceling or suspending any such material, equipment or labor contract, Connecting Transmission Owner shall obtain Developer's authorization to do so.~~

Each Party shall cooperate with the other Parties to maintain the other Parties' tax status.

Nothing in this Agreement is intended to adversely affect the tax status of any Party, including the status of the NYISO.

~~Connecting Transmission Owner shall invoice Developer for such costs pursuant to Article 12 and shall use due diligence to minimize its costs. In the event Developer suspends work by Connecting Transmission Owner required under this Agreement pursuant to this Article 5.16, and has not requested Connecting Transmission Owner to recommence the work required under this Agreement on or before the expiration of three (3) years following commencement of such suspension, this Agreement shall be deemed terminated. The three-year period shall begin on the date the suspension is requested, or the date of the written notice to Connecting Transmission Owner and NYISO, if no effective date is specified.~~

~~4.12.5.12~~ 4.12.5.12 Taxes.

~~4.12.15.12.1~~ 4.12.15.12.1 ~~Developer~~ TrAILCo Payments Not Taxable.

~~The Developer and Connecting Transmission Owner~~ NYSEG and TrAILCo intend that all payments or property transfers made by ~~Developer to Connecting Transmission Owner for the~~ TrAILCo to NYSEG for the procurement, construction and installation of the ~~Connecting Transmission Owner's Attachment Facilities and the~~ NYSEG System Upgrade Facilities ~~and the System Deliverability Upgrades,~~ shall be ~~non-taxable~~ non-taxable, either as contributions to capital, or as an advance, in accordance with the Internal Revenue Code and any applicable state income tax laws and shall not be taxable as contributions in aid of construction or otherwise under the Internal Revenue Code and any applicable state income tax laws.

~~4.12.25.12.2~~ 4.12.25.12.2 Representations and Covenants.

In accordance with IRS Notice 2001-82 and IRS Notice 88-129, ~~Developer~~ as applicable, TrAILCo represents and covenants that ~~(i) ownership of the electricity generated at the Large Generating Facility~~ transmitted at the Point of Interconnection will pass to another party prior to the transmission of the electricity on the New York State Transmission System, ~~(ii) for income tax purposes, the amount of any payments and the cost of any property transferred to the Connecting Transmission Owner for the Connecting Transmission Owner's Attachment Facilities will be capitalized by Developer as an intangible asset and recovered using the straight-line method over a useful life of twenty (20) years, and (iii) any portion of the Connecting Transmission Owner's Attachment Facilities that is a "dual-use intertie," within the meaning of IRS Notice 88-129, is reasonably expected to carry only a de minimis amount of electricity in the direction of the Large Generating Facility. For this purpose, "de minimis amount" means no more than 5 percent of the total power flows in both directions, calculated in accordance with the "5 percent test" set forth in IRS Notice 88-129. This is not intended to be an exclusive list of the relevant conditions that must be met to conform to IRS requirements for non-taxable treatment.~~

~~. NYSEG At Connecting Transmission Owner's request, Developer shall provide Connecting Transmission Owner with a report from an independent engineer confirming its representation in clause (iii), above. Connecting Transmission Owner~~ represents and covenants that the cost of the ~~Connecting Transmission Owner's Attachment~~NYSEG System Upgrade Facilities, paid for by ~~Developer~~TrAILCo, will have no net effect on the base upon which rates are determined.

4.12.35.12.3 Indemnification for the Cost Consequences of Current Tax Liability Imposed Upon ~~the Connecting Transmission Owner~~NYSEG.

Notwithstanding Article ~~5.17.1, Developer~~5.12.1, TrAILCo shall protect, indemnify and hold harmless ~~Connecting Transmission Owner~~NYSEG from the cost consequences of any current tax liability imposed against ~~Connecting Transmission Owner~~NYSEG as the result of payments or property transfers made by ~~Developer to Connecting Transmission Owner~~TrAILCo to NYSEG under this Agreement, as well as any interest and penalties, other than interest and penalties attributable to any delay caused by ~~Connecting Transmission Owner~~NYSEG.

~~Connecting Transmission Owner~~NYSEG shall not include a ~~gross-up~~gross-up for the cost consequences of any current tax liability in the amounts it charges ~~Developer~~TrAILCo under this Agreement unless (i) ~~Connecting Transmission Owner~~NYSEG has determined, in good faith, that the payments or property transfers made by ~~Developer to Connecting Transmission Owner~~TrAILCo to NYSEG should be reported as income subject to taxation or (ii) any Governmental Authority directs ~~Connecting Transmission Owner~~NYSEG to report payments or property as income subject to taxation; provided, however, that ~~Connecting Transmission Owner~~NYSEG may require ~~Developer~~TrAILCo to provide security, in a form reasonably

acceptable to ~~Connecting Transmission Owner~~ NYSEG (such as a parental guarantee or a letter of credit), in an amount equal to the cost consequences of any current tax liability under this Article ~~5.17. Developer~~ 5.12. TrAILCo shall reimburse ~~Connecting Transmission Owner~~ NYSEG for such costs on a fully ~~grossed-up~~ grossed-up basis, in accordance with Article ~~5.17.45.12.4~~, within thirty (30) Calendar Days of receiving written notification from ~~Connecting Transmission Owner~~ NYSEG of the amount due, including detail about how the amount was calculated.

This indemnification obligation shall terminate at the earlier of (1) the expiration of the ~~ten-year~~ ten-year testing period and the applicable statute of limitation, as it may be extended by ~~the Connecting Transmission Owner~~ NYSEG upon request of the IRS, to keep these years open for audit or adjustment, or (2) the occurrence of a subsequent taxable event and the payment of any related indemnification obligations as contemplated by this Article ~~5.17.5.12~~.

4.12.45.12.4 Tax ~~Gross-Up~~ Gross-Up Amount.

~~Developer~~ TrAILCo's liability for the cost consequences of any current tax liability under this Article ~~5.17.5.12~~ shall be calculated on a fully grossed-up basis. Except as may otherwise be agreed to by the ~~parties~~ Parties, this means that ~~Developer~~ TrAILCo will pay ~~Connecting Transmission Owner~~ NYSEG, in addition to the amount paid for the ~~Attachment Facilities and~~ NYSEG System Upgrade Facilities ~~and System Deliverability Upgrades~~, an amount equal to (1) the current taxes imposed on ~~Connecting Transmission Owner~~ NYSEG ("Current Taxes") on the excess of (a) the gross income realized by ~~Connecting Transmission Owner~~ NYSEG as a result of payments or property transfers made by ~~Developer to Connecting Transmission~~

~~Owner~~ TrAILCo to NYSEG under this Agreement (without regard to any payments under this Article ~~5.17~~5.12) (the “Gross Income Amount”) over (b) the present value of future tax deductions for depreciation that will be available as a result of such payments or property transfers (the “Present Value Depreciation Amount”), plus (2) an additional amount sufficient to permit ~~the Connecting Transmission Owner~~ NYSEG to receive and retain, after the payment of all Current Taxes, an amount equal to the net amount described in clause (1).

For this purpose, (i) Current Taxes shall be computed based on ~~Connecting Transmission Owner~~ NYSEG’s composite federal and state tax rates at the time the payments or property transfers are received and ~~Connecting Transmission Owner~~ NYSEG will be treated as being subject to tax at the highest marginal rates in effect at that time (the “Current Tax Rate”), and (ii) the Present Value Depreciation Amount shall be computed by discounting ~~Connecting Transmission Owner~~ NYSEG’s anticipated tax depreciation deductions as a result of such payments or property transfers by ~~Connecting Transmission Owner~~ NYSEG’s current weighted average cost of capital. Thus, the formula for calculating ~~Developer~~ TrAILCo’s liability to ~~Connecting Transmission Owner~~ NYSEG pursuant to this Article ~~5.17.4~~5.12.4 can be expressed as follows: $(\text{Current Tax Rate} \times (\text{Gross Income Amount} - \text{Present Value of Tax Depreciation})) / (1 - \text{Current Tax Rate})$. ~~Developer’s estimated tax liability in the event taxes are imposed shall be stated in Appendix A, Attachment Facilities and System Upgrade Facilities and System Deliverability Upgrades.~~

4.12.55.12.5 Private Letter Ruling or Change or Clarification of Law.

At ~~Developer~~ TrAILCo’s request and expense, ~~Connecting Transmission Owner~~ NYSEG shall file with the IRS a request for a private letter ruling as to whether any property transferred

or sums paid, or to be paid, by ~~Developer to Connecting Transmission Owner~~ TrAILCo to NYSEG under this Agreement are subject to federal income taxation. ~~Developer~~ TrAILCo will prepare the initial draft of the request for a private letter ruling, and will certify under penalties of perjury that all facts represented in such request are true and accurate to the best of ~~Developer~~ TrAILCo's knowledge. ~~Connecting Transmission Owner and Developer~~ NYSEG and TrAILCo shall cooperate in good faith with respect to the submission of such request.

~~Connecting Transmission Owner~~ NYSEG shall keep ~~Developer~~ TrAILCo fully informed of the status of such request for a private letter ruling and shall execute either a privacy act waiver or a limited power of attorney, in a form acceptable to the IRS, that authorizes ~~Developer~~ TrAILCo to participate in all discussions with the IRS regarding such request for a private letter ruling. ~~Connecting Transmission Owner~~ NYSEG shall allow ~~Developer~~ TrAILCo to attend all meetings with IRS officials about the request and shall permit ~~Developer~~ TrAILCo to prepare the initial drafts of any ~~follow-up~~ follow-up letters in connection with the request.

4.12.65.12.6 Subsequent Taxable Events.

If, within 10 years from the date on which the relevant ~~Connecting Transmission Owner~~ Attachment NYSEG System Upgrade Facilities are placed in service, (i) ~~Developer~~ TrAILCo Breaches the covenants contained in Article ~~5.17.25.12.2~~, or (ii) a “disqualification event” occurs ~~within the meaning of IRS Notice 88-129, or (iii)~~ this Agreement terminates and ~~Connecting Transmission Owner~~ NYSEG retains ownership of the ~~Attachment Facilities and~~ NYSEG System Upgrade Facilities ~~and System Deliverability Upgrades, the Developer,~~ TrAILCo shall pay a tax ~~gross-up~~ gross-up for the cost consequences of any current tax liability imposed on ~~Connecting~~

~~Transmission Owner~~NYSEG, calculated using the methodology described in Article ~~5.17.45.12.4~~ and in accordance with IRS Notice 90-60.

~~4.12.75.12.7~~ Contests.

In the event any Governmental Authority determines that ~~Connecting Transmission Owner~~NYSEG's receipt of payments or property constitutes income that is subject to taxation, ~~Connecting Transmission Owner~~NYSEG shall notify ~~Developer~~TrAILCo, in writing, within thirty (30) Calendar Days of receiving notification of such determination by a Governmental Authority. Upon the timely written request by ~~Developer~~TrAILCo and at ~~Developer~~TrAILCo's sole expense, ~~Connecting Transmission Owner~~NYSEG may appeal, protest, seek abatement of, or otherwise oppose such determination. Upon ~~Developer~~TrAILCo's written request and sole expense, ~~Connecting Transmission Owner~~NYSEG may file a claim for refund with respect to any taxes paid under this Article ~~5.175.12~~, whether or not it has received such a determination. ~~Connecting Transmission Owner~~NYSEG reserves the right to make all decisions with regard to the prosecution of such appeal, protest, abatement or other contest, including the selection of counsel and compromise or settlement of the claim, but ~~Connecting Transmission Owner~~NYSEG shall keep ~~Developer~~TrAILCo informed, shall consider in good faith suggestions from ~~Developer~~TrAILCo about the conduct of the contest, and shall reasonably permit ~~Developer or an Developer~~TrAILCo or an TrAILCo representative to attend contest proceedings.

~~Developer~~TrAILCo shall pay to ~~Connecting Transmission Owner~~NYSEG on a periodic basis, as invoiced by ~~Connecting Transmission Owner, Connecting Transmission Owner~~NYSEG, NYSEG's documented reasonable costs of prosecuting such appeal, protest, abatement or other contest. At any time during the contest, ~~Connecting Transmission~~

~~Owner~~NYSEG may agree to a settlement either with ~~Developer~~TrAILCo's consent or after obtaining written advice from nationally-recognized tax counsel, selected by ~~Connecting-Transmission-Owner~~NYSEG, but reasonably acceptable to ~~Developer~~TrAILCo, that the proposed settlement represents a reasonable settlement given the hazards of litigation.

~~Developer~~TrAILCo's obligation shall be based on the amount of the settlement agreed to by ~~Developer~~TrAILCo, or if a higher amount, so much of the settlement that is supported by the written advice from nationally-recognized tax counsel selected under the terms of the preceding sentence. The settlement amount shall be calculated on a fully ~~grossed-up~~grossed-up basis to cover any related cost consequences of the current tax liability. Any settlement without ~~Developer~~TrAILCo's consent or such written advice will relieve ~~Developer~~TrAILCo from any obligation to indemnify ~~Connecting-Transmission-Owner~~NYSEG for the tax at issue in the contest.

4.12.85.12.8 Refund.

In the event that (a) a private letter ruling is issued to ~~Connecting-Transmission-Owner~~NYSEG which holds that any amount paid or the value of any property transferred by ~~Developer to Connecting-Transmission-Owner~~TrAILCo to NYSEG under the terms of this Agreement is not subject to federal income taxation, (b) any legislative change or administrative announcement, notice, ruling or other determination makes it reasonably clear to ~~Connecting-Transmission-Owner~~NYSEG in good faith that any amount paid or the value of any property transferred by ~~Developer to Connecting-Transmission-Owner~~TrAILCo to NYSEG under the terms of this Agreement is not taxable to ~~Connecting-Transmission-Owner~~NYSEG, (c) any

abatement, appeal, protest, or other contest results in a determination that any payments or transfers made by ~~Developer to Connecting Transmission Owner~~ TrAILCo to NYSEG are not subject to federal income tax, or (d) if ~~Connecting Transmission Owner~~ NYSEG receives a refund from any taxing authority for any overpayment of tax attributable to any payment or property transfer made by ~~Developer to Connecting Transmission Owner~~ TrAILCo to NYSEG pursuant to this Agreement, ~~Connecting Transmission Owner~~ NYSEG shall promptly refund to ~~Developer~~ TrAILCo the following:

(i) Any payment made by ~~Developer~~ TrAILCo under this Article ~~5.175.12~~ for taxes that is attributable to the amount determined to be non-taxable, together with interest thereon,

(ii) Interest on any amounts paid by ~~Developer to Connecting Transmission Owner~~ TrAILCo to NYSEG for such taxes which ~~Connecting Transmission Owner~~ NYSEG did not submit to the taxing authority, calculated in accordance with the methodology set forth in FERC's regulations at 18 C.F.R. §35.19a(a)(2)(iii) from the date payment was made by ~~Developer~~ TrAILCo to the date ~~Connecting Transmission Owner~~ NYSEG refunds such payment to ~~Developer~~ TrAILCo, and

(iii) With respect to any such taxes paid by ~~Connecting Transmission Owner~~ NYSEG, any refund or credit ~~Connecting Transmission Owner~~ NYSEG receives or to which it may be entitled from any Governmental Authority, interest (or that portion thereof attributable to the payment described in clause (i), above) owed to ~~the Connecting Transmission Owner~~ NYSEG for such overpayment of taxes (including any reduction in interest otherwise payable by ~~Connecting Transmission Owner~~ NYSEG to any Governmental Authority resulting from an offset or credit);

provided, however, that ~~Connecting Transmission Owner~~ NYSEG will remit such amount promptly to ~~Developer~~ TrAILCo only after and to the extent that ~~Connecting Transmission Owner~~ NYSEG has received a tax refund, credit or offset from any Governmental Authority for any applicable overpayment of income tax related to the ~~Connecting Transmission Owner's Attachment~~ NYSEG System Upgrade Facilities.

The intent of this provision is to leave both ~~the Developer~~ TrAILCo and ~~Connecting Transmission Owner~~ NYSEG, to the extent practicable, in the event that no taxes are due with respect to any payment for ~~Attachment Facilities and~~ NYSEG System Upgrade Facilities and System Deliverability Upgrades hereunder, in the same position they would have been in had no such tax payments been made.

~~4.13~~ — Taxes Other Than Income Taxes .

Upon the timely request by ~~Developer~~ TrAILCo, and at ~~Developer~~ TrAILCo's sole expense, ~~Connecting Transmission Owner~~ NYSEG shall appeal, protest, seek abatement of, or otherwise contest any tax (other than federal or state income tax) asserted or assessed against ~~Connecting Transmission Owner~~ NYSEG for which ~~Developer~~ TrAILCo may be required to reimburse ~~Connecting Transmission Owner~~ NYSEG under the terms of this Agreement. ~~Developer~~ TrAILCo shall pay to ~~Connecting Transmission Owner~~ NYSEG on a periodic basis, as invoiced by ~~Connecting Transmission Owner, Connecting Transmission Owner~~ NYSEG, NYSEG's documented reasonable costs of prosecuting such appeal, protest, abatement, or other contest. ~~Developer and Connecting Transmission Owner~~ TrAILCo and NYSEG shall cooperate in good faith with respect to any such contest. Unless the payment of such taxes is a prerequisite to an appeal or abatement or cannot be deferred, no amount shall be payable by ~~Developer to~~

~~Connecting Transmission Owner~~ TrAILCo to NYSEG for such taxes until they are assessed by a final, ~~non-appealable~~ nonappealable order by any court or agency of competent jurisdiction. In the event that a tax payment is withheld and ultimately due and payable after appeal, ~~Developer~~ TrAILCo will be responsible for all taxes, interest and penalties, other than penalties attributable to any delay caused by ~~Connecting Transmission Owner~~ NYSEG.

~~2.8~~ Tax Status; Non-Jurisdictional Entities.

~~2.8.1~~ Tax Status.

~~Each Party shall cooperate with the other Parties to maintain the other Parties' tax status. Nothing in this Agreement is intended to adversely affect the tax status of any Party including the status of NYISO, or the status of any Connecting Transmission Owner with respect to the issuance of bonds including, but not limited to, Local Furnishing Bonds. Notwithstanding any other provisions of this Agreement, LIPA, NYPA and Consolidated Edison Company of New York, Inc. shall not be required to comply with any provisions of this Agreement that would result in the loss of tax-exempt status of any of their Tax-Exempt Bonds or impair their ability to issue future tax-exempt obligations. For purposes of this provision, Tax-Exempt Bonds shall include the obligations of the Long Island Power Authority, NYPA and Consolidated Edison Company of New York, Inc., the interest on which is not included in gross income under the Internal Revenue Code.~~

~~2.8.2~~ Non-Jurisdictional Entities.

~~LIPA and NYPA do not waive their exemptions, pursuant to Section 201(f) of the FPA, from Commission jurisdiction with respect to the Commission's exercise of the FPA's general ratemaking authority.~~

~~4.14~~ 5.13 Modification.

~~4.14.15.13.1~~ General.

Either ~~the Developer or Connecting Transmission Owner~~ NYSEG or TrAILCo may undertake modifications to its facilities covered by this Agreement. If either ~~the Developer or Connecting Transmission Owner~~ NYSEG or TrAILCo plans to undertake a modification that reasonably may be expected to affect the other Party's facilities, that Party shall provide to the other Party, and to NYISO, sufficient information regarding such modification so that the other

Party and NYISO may evaluate the potential impact of such modification prior to commencement of the work. Such information shall be deemed to be Confidential Information hereunder and shall include information concerning the timing of such modifications and whether such modifications are expected to interrupt the ~~flow~~transmission of electricity ~~from the Large Generating Facility~~at the Point(s) of Interconnection. The Party desiring to perform such work shall provide the relevant drawings, plans, and specifications to the other Party and NYISO at least ninety (90) Calendar Days in advance of the commencement of the work or such shorter period upon which the Parties may agree, which agreement shall not unreasonably be withheld, conditioned or delayed.

In the case of ~~Large Generating~~Transmission Facility modifications, the Party making such modification shall provide reasonable prior notice of such modifications to the other Parties. For modifications that do not require ~~Developer~~TrAILCo or NYSEG to submit an Interconnection Request, the NYISO ~~shall,~~ in consultation with the other Parties, shall use Reasonable Efforts to provide, within sixty (60) Calendar Days (or such other time as the Parties may agree), an estimate of any additional modifications to the New York State Transmission System, ~~Connecting Transmission Owner's Attachment Facilities~~ or System Upgrade Facilities ~~or System Deliverability Upgrades~~ necessitated by such ~~Developer~~ modification and a good faith estimate of the costs thereof. ~~The Developer~~TrAILCo shall be responsible for the cost of any such additional modifications, including the cost of studying the impact of the ~~Developer~~TrAILCo modification.

4.14.25.13.2 Standards.

~~Any additions, modifications, or replacements made to a Party's facilities shall be designed, constructed and operated in accordance with this Agreement, NYISO requirements and Good Utility Practice.~~

Except as provided in Appendix A or C, (a) any additions, modifications, or replacements made to TrAILCo's facilities shall be designed, constructed and operated in accordance with this Agreement, applicable NYISO and PJM requirements, and Good Utility Practice, and (b) any additions, modifications, or replacements made to NYSEG's facilities shall be designed, constructed and operated in accordance with this Agreement, applicable NYISO requirements, and Good Utility Practice.

4.14.35.13.3 Modification Costs.

NYSEG shall not be assigned the costs of any additions, modifications, or replacements that TrAILCo makes to System Upgrade Facilities owned by TrAILCo, or the PJM Transmission System to facilitate the interconnection of a third party to the System Upgrade Facilities owned by TrAILCo, or the PJM Transmission System, or to provide Transmission Service to a third party under the PJM OATT. NYSEG shall be responsible for the costs of any additions, modifications, or replacements to the System Upgrade Facilities owned by NYSEG, that may be necessary to maintain or upgrade such NYSEG System Upgrade Facilities consistent with Applicable Laws and Regulations, Applicable Reliability Standards or Good Utility Practice except if such additions, modifications, or replacements are required as a result of modifications made by TrAILCo to its System Upgrade Facilities, in which case TrAILCo shall be responsible for such costs.

~~Developer~~TrAILCo shall not be assigned the costs of any additions, modifications, or replacements that ~~Connecting Transmission Owner~~NYSEG makes to the ~~Connecting Transmission Owner's Attachment~~System Upgrade Facilities owned by NYSEG, or the New York State Transmission System to facilitate the interconnection of a third party to the ~~Connecting Transmission Owner's Attachment~~System Upgrade Facilities owned by NYSEG, or the New York State Transmission System, or to provide Transmission Service to a third party under the NYISO ~~OATT~~Tariff, except in accordance with the cost allocation procedures in Attachment S of the NYISO ~~OATT~~Developer Tariff or as approved by the appropriate Governmental Authority. TrAILCo shall be responsible for the costs of any additions, modifications, or replacements to the ~~Developer Attachment~~System Upgrade Facilities owned by TrAILCo, that may be necessary to maintain or upgrade such ~~Developer Attachment~~TrAILCo System Upgrade Facilities consistent with Applicable Laws and Regulations, Applicable Reliability Standards or Good Utility Practice except if such additions, modifications, or replacements are required as a result of modifications made by NYSEG to its System Upgrade Facilities, in which case NYSEG shall be responsible for such costs.

~~ARTICLE 5.~~ARTICLE 6. TESTING AND INSPECTION

~~5.16.1~~5.16.1 Pre-Commercial Operation Date Testing and Modifications.

Prior to the Commercial Operation Date, ~~the Connecting Transmission Owner~~TrAILCo shall test ~~the Connecting Transmission Owner's Attachment Facilities and~~its System Upgrade Facilities, and ~~System Deliverability Upgrades and Developer~~NYSEG shall test ~~the Large Generating Facility and the Developer Attachment~~its System Upgrade Facilities to ensure their safe and reliable operation. Similar testing may be required after initial operation. ~~Developer~~

~~and Connecting Transmission Owner~~ NYSEG and TrAILCo shall each make any modifications to its facilities that are found to be necessary as a result of such testing. ~~Developer~~ TrAILCo shall bear the cost of all such testing and modifications. ~~Developer shall generate to its and NYSEG's~~ System Upgrade Facilities. NYSEG and TrAILCo shall transmit test energy ~~at the Large-Generating Facility~~ through the Point(s) of Interconnection only if it has arranged for the ~~injection~~ transmission of such test energy in accordance with TrAILCo, PJM, NYSEG and NYISO procedures.

5.26.2 Post-Commercial Operation Date Testing and Modifications.

~~Developer and Connecting Transmission Owner~~ NYSEG and TrAILCo shall each at its own expense perform routine inspection and testing of its facilities and equipment in accordance with Good Utility Practice and Applicable Reliability Standards as may be necessary to ensure the continued interconnection of the ~~Large-Generating Facility~~ Mainesburg Substation with the New York State Transmission System in a safe and reliable manner. ~~Developer and Connecting Transmission Owner~~ NYSEG and TrAILCo shall each have the right, upon advance written notice, to require reasonable additional testing of the other Party's facilities, at the requesting Party's expense, as may be in accordance with Good Utility Practice.

5.36.3 Right to Observe Testing.

~~Developer and Connecting Transmission Owner~~ NYSEG and TrAILCo shall each notify the other Party, and the NYISO, in advance of its performance of tests of ~~its Attachment~~ the System Upgrade Facilities. The other Party, and the NYISO, shall ~~each~~ have the right, at its own expense, to observe such testing.

5.46.4 Right to Inspect.

~~Developer and Connecting Transmission Owner~~ NYSEG and TrAILCo shall each have the right, but shall have no obligation to: (i) observe the other Party's tests and/or inspection of any of its System Protection Facilities and other protective equipment, ~~including Power System Stabilizers~~; (ii) review the settings of the other Party's System Protection Facilities and other protective equipment; and (iii) review the other Party's maintenance records relative to the ~~Attachment~~ System Upgrade Facilities, the System Protection Facilities and other protective equipment. NYISO shall have ~~these~~ the same rights of inspection as to the facilities and equipment of ~~Developer and Connecting Transmission Owner~~ NYSEG and TrAILCo. A Party may exercise these rights from time to time as it deems necessary upon reasonable notice to the other Party. The exercise or non-exercise by a Party of any such rights shall not be construed as an endorsement or confirmation of any element or condition of the ~~Attachment~~ System Upgrade Facilities, or the System Protection Facilities or other protective equipment or the operation thereof, or as a warranty as to the fitness, safety, desirability, or reliability of same. Any information that a Party obtains through the exercise of any of its rights under this Article 6.4 shall be treated in accordance with Article 22 of this Agreement ~~and Attachment F to the NYISO OATT~~.

~~ARTICLE 6.~~ ARTICLE 7. METERING

6.17.1 General.

~~Developer and Connecting Transmission Owner~~ NYSEG and TrAILCo shall each comply with applicable requirements of the NYISO ~~and the New York Public Service Commission~~ when exercising its rights and fulfilling its responsibilities under this Article 7. Unless otherwise

agreed by ~~the Connecting Transmission Owner and NYISO approved meter service provider and Developer, the Connecting Transmission Owner~~ TrAILCo and NYSEG, TrAILCo shall install Metering Equipment at the ~~Point~~ Point(s) of Interconnection prior to any operation of the ~~Large-Generating~~ Transmission Facility and shall ~~own,~~ operate, test and maintain such Metering Equipment. Net power flows including MW and MVAR, MWHR and loss profile data to and from the ~~Large-Generating-Facility~~ Watercure Line shall be measured at the ~~Point~~ Point(s) of Interconnection. ~~Connecting Transmission Owner~~ TrAILCo shall provide metering quantities, in analog and/or digital form, as required, to ~~Developer or NYISO~~ the other Parties, upon request. ~~Where the Point of Interconnection for the Large-Generating Facility is other than the generator terminal, the Developer shall also provide gross MW and MVAR quantities at the generator terminal.~~ ~~Developer~~ TrAILCo shall bear all reasonable documented costs associated with the purchase, installation, operation, testing and maintenance of the Metering Equipment.

6.27.2 Check Meters.

~~Developer~~ NYSEG, at its option and expense, may install and operate, on its premises and on its side of the Point of Interconnection, one or more check meters to check ~~Connecting-Transmission-Owner~~ TrAILCo's meters. Such check meters shall be for check purposes only and shall not be used for the measurement of power flows for purposes of this Agreement, except as provided in Article ~~7.4~~ 7.4 below. The check meters shall be subject at all reasonable times to inspection and examination by ~~Connecting-Transmission-Owner~~ TrAILCo or its designee. The installation, operation and maintenance thereof shall be performed entirely by ~~Developer~~ NYSEG in accordance with Good Utility Practice.

6.37.3 Standards.

~~Connecting Transmission Owner~~ TrAILCo shall install, calibrate, and test revenue quality Metering Equipment including potential transformers and current transformers in accordance with applicable ANSI and ~~PSC~~ Governmental Authority standards ~~as detailed in the NYISO Control Center Communications Manual and in the NYISO Revenue Metering Requirements Manual, including applicable NYISO requirements.~~

6.47.4 Testing of Metering Equipment.

~~Connecting Transmission Owner~~ TrAILCo shall inspect and test all of ~~its~~ the Metering Equipment upon installation and ~~at least once every two (2) years thereafter. If requested to do so by NYISO or Developer, Connecting Transmission Owner shall, at Developer's expense, inspect or test Metering Equipment more frequently than every two (2) years. Connecting Transmission Owner~~ in accordance with applicable NYISO requirements. TrAILCo shall give reasonable notice of the time when any inspection or test shall take place, and ~~Developer and NYISO~~ NYSEG may have representatives present at the test or inspection. If at any time Metering Equipment is found to be inaccurate or defective, it shall be adjusted, repaired or replaced at ~~Developer~~ the owner's expense, in order to provide accurate metering, unless the inaccuracy or defect is due to ~~Connecting Transmission Owner~~ TrAILCo's failure to maintain, then ~~Connecting Transmission Owner~~ TrAILCo shall pay. If Metering Equipment fails to register, or if the measurement made by Metering Equipment during a test varies by more than ~~two percent from the measurement made by the standard meter used in the test, Connecting Transmission Owner~~ the range set forth in the applicable NYISO or PJM standard, TrAILCo shall adjust the measurements by correcting all measurements for the period during which Metering

Equipment was in error by using ~~Developer~~the other Party's check meters, if installed. If no such check meters are installed or if the period cannot be reasonably ascertained, the adjustment shall be for the period immediately preceding the test of the Metering Equipment equal to one-half the time from the date of the last previous test of the Metering Equipment. ~~The~~NYISO ~~shall reserve~~reserves the right to ~~review all associated metering equipment installation on the Developer's or Connecting Transmission Owner~~inspect all Metering Equipment installed on NYSEG's or TrAILCo's property at any timereasonable times and upon reasonable notice to NYSEG or TrAILCo, as applicable.

6.57.5 Metering Data.

~~At Developer~~Subject to the provisions of Appendix C, and at TrAILCo's expense, the metered data shall be telemetered to one or more locations designated by ~~Connecting Transmission Owner, Developer and NYISO~~TrAILCo and NYSEG. Such telemetered data shall be used, under normal operating conditions, as the official measurement of the amount of energy delivered from the ~~Large Generating~~Watercure Line to the Point of Interconnection and/or from the Transmission Facility to the Point of Interconnection.

~~ARTICLE 7.~~ARTICLE 8. COMMUNICATIONS

7.18.1 ~~Developer~~TrAILCo Obligations.

In accordance with applicable NYISO requirements, ~~Developer shall~~and subject to Appendix C, TrAILCo shall install and maintain satisfactory operating communications with ~~Connecting Transmission Owner~~NYSEG and NYISO. ~~Developer~~TrAILCo shall provide ~~standard voice line, dedicated voice line and facsimile communications at its Large Generating~~

~~Facility control room or central dispatch facility through use of either the public telephone system, or a voice communications system that does not rely on the public telephone system.~~
~~Developer shall also provide the~~the equipment, labor and contract services and dedicated data circuit(s) necessary to provide ~~Developer~~TrAILCo data to ~~Connecting Transmission Owner~~NYSEG and NYISO ~~as set forth in Appendix D hereto~~in accordance with applicable NYISO and NYSEG requirements. The data circuit(s) shall extend from the ~~Large-Generating Transmission~~ Facility to the location(s) specified by ~~Connecting Transmission Owner and NYISO~~NYSEG. Any required repair, replacement or maintenance of such communications equipment shall be performed by ~~Developer~~TrAILCo. Operational communications shall be activated and maintained under, but not ~~be~~ limited to, the following events: system paralleling or separation, scheduled and unscheduled ~~shutdowns~~outages, equipment clearances, and hourly and daily load data. Prior to the Commercial Operation Date, satisfactory communications shall be in place, in accordance with this Article 8.1 and Paragraph B(2) of Appendix C.

7.28.2 Remote Terminal Unit.

~~Prior to the Initial Synchronization Date of the Large Generating Facility, a~~A Remote Terminal Unit, or equivalent data collection and transfer equipment acceptable to the Parties, shall be installed by ~~Developer, or by Connecting Transmission Owner at Developer~~TrAILCo at TrAILCo's expense, in accordance with Section B(2) of Appendix C, to gather accumulated and instantaneous data to be telemetered to the location(s) designated by ~~Connecting Transmission Owner and NYISO through use of a dedicated point to point data circuit(s) as indicated in Article 8.1. The communication protocol for the data circuit(s) shall be specified by Connecting Transmission Owner and NYISO. Instantaneous bi-directional analog real power and reactive power flow information must be telemetered directly to the location(s) specified by Connecting Transmission Owner and NYISO.~~

TrAILCo. Each Party will promptly advise the appropriate other Party if it detects or otherwise learns of any metering, telemetry or communications equipment errors or malfunctions

that require the attention and/or correction by that other Party. The Party owning such equipment shall correct such error or malfunction as soon as reasonably feasible.

7.38.3 No Annexation.

Any and all equipment placed on the premises of a Party shall be and remain the property of the Party providing such equipment regardless of the mode and manner of annexation or attachment to real property, unless otherwise mutually agreed by the Party providing such equipment and the Party receiving such equipment.

~~ARTICLE 8.~~ARTICLE 9. OPERATIONS

8.19.1 General.

Each Party shall comply with Applicable Laws and Regulations and Applicable Reliability Standards. Each Party shall provide to the other Parties all information that may reasonably be required by the other Parties to comply with Applicable Laws and Regulations and Applicable Reliability Standards.

~~8.29.2~~ NYISO and Connecting Transmission Owner NYSEG Obligations.

~~Connecting Transmission Owner and NYISO shall cause the New York State Transmission System and the Connecting Transmission Owner's Attachment Facilities to be operated, maintained and controlled in a safe and reliable manner in accordance with this Agreement and the NYISO Tariffs. Connecting Transmission Owner and NYISO may provide operating instructions to Developer consistent with this Agreement, NYISO procedures and Connecting Transmission Owner's operating protocols and procedures as they may change from time to time. Connecting Transmission Owner and NYISO will consider changes to their respective operating protocols and procedures proposed by Developer.~~

NYSEG shall, at its own expense, operate, maintain and control the System Upgrade Facilities owned by NYSEG in a safe and reliable manner in accordance with this Agreement and the NYISO Tariff.

8.39.3 Developer TrAILCo Obligations.

~~Developer TrAILCo shall, at its own expense, operate, maintain and control the Large Generating Facility and the Developer Attachment System Upgrade Facilities owned by TrAILCo, including the Transmission Facility, in a safe and reliable manner ~~and~~ in accordance with this Agreement. ~~Developer shall operate the Large Generating Facility and the Developer Attachment Facilities in accordance with NYISO and Connecting Transmission Owner requirements, as such requirements are set forth or referenced in Appendix C hereto. Appendix C will be modified to reflect changes to the requirements as they may change from time to time. Any Party may request that the appropriate other Party or Parties provide copies of the requirements set forth or referenced in Appendix C hereto. and the PJM Tariff.~~ and the PJM Tariff.~~

8.49.4 Start-Up and Synchronization.

Consistent with the mutually acceptable procedures of ~~the Developer and Connecting Transmission Owner, the Developer is~~ NYSEG and TrAILCo and the NYISO and PJM, NYSEG and TrAILCo are responsible for the proper synchronization of the ~~Large Generating Facility~~ Mainesburg Substation to the New York State Transmission System ~~in accordance with NYISO and Connecting Transmission Owner procedures and requirements.~~

~~2.9 Real and Reactive Power Control.~~

~~2.9.1 Power Factor Design Criteria.~~

~~Developer shall design the Large Generating Facility to maintain an effective power delivery at demonstrated maximum net capability at the Point of Intereconnection at a power factor within the range established by the Connecting Transmission Owner on a comparable basis, until NYISO has established different requirements that apply to all generators in the New York Control Area on a comparable basis.~~

8.59.5 [Reserved]

~~The Developer shall design and maintain the plant auxiliary systems to operate safely throughout the entire real and reactive power design range.~~

~~The Connecting Transmission Owner shall not unreasonably restrict or condition the reactive power production or absorption of the Large Generating Facility in accordance with Good Utility Practice.~~

~~**2.9.2 Voltage Schedules.**~~

~~Once the Developer has synchronized the Large Generating Facility with the New York State Transmission System, NYISO shall require Developer to operate the Large Generating Facility to produce or absorb reactive power within the design capability of the Large Generating Facility set forth in Article 9.5.1 (Power Factor Design Criteria). NYISO's voltage schedules shall treat all sources of reactive power in the New York Control Area in an equitable and not unduly discriminatory manner. NYISO shall exercise Reasonable Efforts to provide Developer with such schedules in accordance with NYISO procedures, and may make changes to such schedules as necessary to maintain the reliability of the New York State Transmission System. Developer shall operate the Large Generating Facility to maintain the specified output voltage or power factor at the Point of Interconnection within the design capability of the Large Generating Facility set forth in Article 9.5.1 (Power Factor Design Criteria) as directed by the Connecting Transmission Owner's System Operator or the NYISO. If Developer is unable to maintain the specified voltage or power factor, it shall promptly notify NYISO.~~

~~**2.9.3 Payment for Reactive Power.**~~

~~NYISO shall pay Developer for reactive power or voltage support service that Developer provides from the Large Generating Facility in accordance with the provisions of Rate Schedule 2 of the NYISO Services Tariff.~~

~~**2.9.4 Governors and Regulators.**~~

~~Whenever the Large Generating Facility is operated in parallel with the New York State Transmission System, the turbine speed governors and automatic voltage regulators shall be in automatic operation at all times. If the Large Generating Facility's speed governors or automatic voltage regulators are not capable of such automatic operation, the Developer shall immediately notify NYISO, or its designated representative, and ensure that such Large Generating Facility's real and reactive power are within the design capability of the Large Generating Facility's generating unit(s) and steady state stability limits and NYISO system operating (thermal, voltage and transient stability) limits. Developer shall not cause its Large Generating Facility to disconnect automatically or instantaneously from the New York State Transmission System or trip any generating unit comprising the Large Generating Facility for an under or over frequency condition unless the abnormal frequency condition persists for a time period beyond the limits set forth in ANSI/IEEE Standard C37.106, or such other standard as applied to other generators in the New York Control Area on a comparable basis.~~

8.69.6 Outages and Interruptions.

8.6.19.6.1 Outages.

8.6.1.1 Outage Authority and Coordination.

8.6.1.2~~9.6.1.1~~ NYSEG ~~Developer and Connecting Transmission Owner~~

may ~~each~~, in accordance with applicable NYISO procedures and Good Utility Practice, and in coordination with ~~the other Party~~ TrAILCo remove from service any of its respective System Upgrade Facilities that may impact TrAILCo's facilities as necessary to perform maintenance or testing or to install or replace equipment. TrAILCo may, in accordance with applicable PJM procedures and Good Utility Practice, and in coordination with NYSEG, remove from service any of its respective ~~Attachment Facilities or System Upgrade Facilities and System Deliverability Upgrades~~ that may impact ~~the other Party~~ NYSEG's facilities as necessary to perform maintenance or testing or to install or replace equipment. Absent an Emergency, or Emergency State, the Party scheduling a removal of such facility(ies) from service will use Reasonable Efforts to schedule such removal on a date and time mutually acceptable to both ~~the Developer and the Connecting Transmission Owner~~ NYSEG and TrAILCo. In all circumstances either Party planning to remove such facility(ies) from service shall use Reasonable Efforts to minimize the effect on the other Party of such removal.

8.6.1.3 Outage Schedules.

8.6.1.4~~9.6.1.2~~ NYSEG ~~The Connecting Transmission Owner~~ shall post

scheduled outages of its transmission facilities on the NYISO OASIS. ~~Developer shall submit its planned maintenance schedules for the Large Generating Facility to Connecting Transmission Owner and NYISO for a minimum of a rolling thirty six month period. Developer shall update its planned maintenance schedules as necessary. NYISO may direct, or the Connecting Transmission Owner may request, Developer to reschedule its maintenance as necessary to~~

~~maintain the reliability of the New York State Transmission System. Compensation to Developer for any additional direct costs that the Developer incurs as a result of rescheduling maintenance, including any additional overtime, breaking of maintenance contracts or other costs above and beyond the cost the Developer would have incurred absent the request to reschedule maintenance, shall be in accordance with the NYISO OATT. Developer will not be eligible to receive compensation, if during the twelve (12) months prior to the date of the scheduled maintenance, the Developer had modified its schedule of maintenance activities other than at the direction of the NYISO or request of the Connecting Transmission Owner, and TrAILCo shall post scheduled outages of its transmission facilities on the PJM OASIS.~~

8.6.1.5 Outage Restoration.

~~8.6.1.6~~**9.6.1.3** If an outage on the ~~Attachment Facilities or System~~

~~Upgrade Facilities or System Deliverability Upgrades of the Connecting Transmission Owner or Developer~~of TrAILCo or NYSEG adversely affects the other Party's operations or facilities, the Party that owns the facility that is out of service shall use Reasonable Efforts to promptly restore such facility(ies) to a normal operating condition consistent with the nature of the outage. The Party that owns the facility that is out of service shall provide the other Party, and to the NYISO, or PJM, as applicable, to the extent such information is known, information on the nature of the Emergency or Emergency State, an estimated time of restoration, and any corrective actions required. Initial verbal notice shall be followed up as soon as practicable with written notice explaining the nature of the outage.

~~8.6.2~~**9.6.2** **Interruption of Service.** If required by Good Utility Practice or Applicable Reliability Standards to do so, ~~the NYISO or Connecting Transmission~~

~~Owner~~ TrAILCo may require ~~Developer~~ NYSEG to interrupt or reduce ~~production~~ transmission of electricity ~~if such production of electricity could adversely affect the ability of NYISO and Connecting Transmission Owner to perform such activities as are necessary to safely and reliably operate and maintain the New York State Transmission System~~ over the Watercure Line, and NYSEG may require TrAILCo to interrupt or reduce transmission of electricity over the Transmission Facility if either TrAILCo, NYSEG or the NYISO deems the interruption of such transmission of electricity to be necessary: (a) for purposes of Good Utility Practice, to protect a Party's facilities from physical damage or to prevent injury or damage to persons or property; or (b) to comply with Applicable Reliability Standards. The following provisions shall apply to any interruption or reduction permitted under this Article 9.6.2:

~~8.6.2.1~~ 9.6.2.1 The interruption or reduction shall continue only for so long as reasonably necessary to: (a) protect its facilities from physical damage or to prevent injury or damage to persons or property under Good Utility Practice; or (b) comply with Applicable Reliability Standards;

~~8.6.2.2~~ 9.6.2.2 Any such interruption or reduction shall be made on an equitable, non-discriminatory basis with respect to all ~~generating~~ transmission facilities directly connected to that part of the PJM Transmission System and New York State Transmission System owned, respectively, by TrAILCo or NYSEG;

~~8.6.2.3~~ 9.6.2.3 When the interruption or reduction must be made under circumstances which do not allow for advance notice, ~~NYISO or Connecting Transmission Owner~~ TrAILCo or NYSEG, as applicable, shall notify ~~Developer~~ the other Party (and the NYISO) by telephone as soon as practicable of the reasons for the curtailment, interruption, or

reduction, and, if known, its expected duration. Telephone notification shall be followed by written notification as soon as practicable;

~~8.6.2.4~~9.6.2.4 Except during the existence of an Emergency or Emergency State, when the interruption or reduction can be scheduled without advance notice, ~~NYISO or Connecting Transmission Owner~~TrAILCo or NYSEG, as applicable, shall notify ~~Developer~~the other Party (and the NYISO) in advance regarding the timing of such scheduling and further notify ~~Developer~~the other Party (and the NYISO) of the expected duration. ~~NYISO or Connecting Transmission Owner~~TrAILCo and NYSEG, as applicable, shall coordinate with ~~each~~the other Party (and the Developer~~NYISO)~~ using Good Utility Practice to schedule the interruption or reduction during periods of least impact to ~~the Developer, the Connecting Transmission Owner and the~~both NYSEG and TrAILCo, the New York State Transmission System, and the PJM Transmission System; and

~~8.6.2.5~~9.6.2.5 The Parties shall cooperate and coordinate with each other, and the PJM and NYISO, to the extent necessary in order to restore the ~~Large Generating Facility, Attachment~~Watercure Line, System Upgrade Facilities, ~~and~~ the New York State Transmission System, and the PJM Transmission System to their normal operating state, consistent with system conditions and Good Utility Practice, and in accordance with the directives of the NYISO and PJM.

~~2.9.5~~ ~~Under-Frequency and Over-Frequency Conditions.~~

~~The New York State Transmission System is designed to automatically activate a load-shed program as required by the NPCC in the event of an under-frequency system disturbance. Developer shall implement under-frequency and over-frequency relay set points for the Large Generating Facility as required by the NPCC to ensure “ride-through” capability of the New York State Transmission System. Large Generating Facility response to frequency deviations of predetermined magnitudes, both under-frequency and over-frequency deviations, shall be studied and coordinated with the NYISO and Connecting Transmission Owner in accordance with Good Utility Practice. The term “ride-through” as used herein shall mean the ability of a Generating Facility to stay connected to and synchronized with the New York State Transmission System during system disturbances within a range of under-frequency and over-frequency conditions, in accordance with Good Utility Practice and with NPCC Regional Reliability Reference Directory #12.~~

~~8.6.3~~9.6.3 **System Protection and Other Control Requirements.**

~~8.6.3.1~~9.6.3.1 **System Protection Facilities.** ~~Developer~~TrAILCo shall install, operate and maintain, at its expense, ~~install, operate and maintain~~any System Protection Facilities ~~as a part of the Large Generating Facility or Developer Attachment Facilities.~~ Connecting Transmission Ownerthat may be required on TrAILCo’s facilities, including its System Upgrade Facilities, as a result of the interconnection of the Transmission Facility to the New York State Transmission System. NYSEG shall install at ~~Developer~~TrAILCo’s expense any System Protection Facilities that may be required on the ~~Connecting Transmission Owner Attachment~~NYSEG’s facilities, including its System Upgrade Facilities or the New York State Transmission System as a result of the interconnection of the ~~Large Generating~~Transmission Facility ~~and Developer Attachment Facilities~~to the New York State Transmission System.

~~8.6.3.2~~9.6.3.2 The protection facilities of both ~~the Developer and Connecting Transmission Owner~~NYSEG and TrAILCo shall be designed and coordinated with other systems in accordance with Good Utility Practice and Applicable Reliability Standards.

~~8.6.3.3~~9.6.3.3 ~~The Developer and Connecting Transmission~~

~~Owner~~NYSEG and TrAILCo shall each be responsible for protection of its respective facilities consistent with Good Utility Practice and Applicable Reliability Standards.

~~8.6.3.4~~9.6.3.4 ~~The protective relay design of the Developer and~~

~~Connecting Transmission Owner~~NYSEG and TrAILCo shall each incorporate the necessary test switches to perform the tests required in Article 6 of this Agreement. The required test switches will be placed such that they allow operation of lockout relays while preventing breaker failure schemes from operating and causing unnecessary breaker operations and/or the tripping of ~~the Developer~~NYSEG's Large Generating Facility Watercure Line or the System Upgrade Facilities.

~~8.6.3.5~~9.6.3.5 ~~The Developer and Connecting Transmission~~

~~Owner~~NYSEG and TrAILCo will each test, operate and maintain System Protection Facilities in accordance with Good Utility Practice and applicable ReliabilityFirst and NPCC criteria.

~~8.6.3.6~~9.6.3.6 ~~Prior to the In-Service Date, and again prior to the~~

Commercial Operation Date, ~~the Developer and Connecting Transmission Owner~~NYSEG and TrAILCo shall each perform, or their agents shall perform, a complete calibration test and functional trip test of the System Protection Facilities. At intervals suggested by Good Utility Practice and following any apparent malfunction of the System Protection Facilities, ~~the Developer and Connecting Transmission Owner~~NYSEG and TrAILCo shall each perform both calibration and functional trip tests of ~~its~~the System Protection Facilities in a manner and at intervals consistent with TrAILCo's standard practice for performing such tests. These tests do

not require the tripping of any in-service generation unit. These tests do, however, require that all protective relays and lockout contacts be activated.

8.6.49.6.4 Requirements for Protection.

In compliance with applicable ReliabilityFirst and NPCC requirements, and Good Utility Practice, ~~Developer~~NYSEG and TrAILCo, as applicable, shall provide, install, own, and maintain relays, circuit breakers and all other devices necessary to remove any fault contribution of the ~~Large Generating Facility~~Watercure Line or the Mainesburg Substation to any short circuit occurring on the New York State Transmission System or the PJM Transmission System not otherwise isolated by ~~Connecting Transmission Owner~~the other Party's equipment, such that the removal of the fault contribution shall be coordinated with the protective requirements of the New York State Transmission System or the PJM Transmission System. Such protective equipment shall include, without limitation, a disconnecting device or switch with load-interrupting capability located between the ~~Large Generating~~Transmission Facility and the New York State Transmission System at a site selected upon mutual agreement (not to be unreasonably withheld, conditioned or delayed) of ~~the Developer and Connecting Transmission Owner. Developer shall be responsible for protection of the Large Generating Facility and Developer's other equipment from such conditions as negative sequence currents, over or under frequency, sudden load rejection, over or under voltage, and generator loss of field. Developer shall be solely responsible to disconnect the Large Generating Facility and Developer's other equipment if conditions on the New York State Transmission System could adversely affect the Large Generating Facility.~~NYSEG and TrAILCo.

8.6.59.6.5 Power Quality.

Neither the facilities of ~~Developer~~NYSEG nor the facilities of ~~Connecting Transmission Owner~~TrAILCo shall cause excessive voltage flicker nor introduce excessive distortion to the sinusoidal voltage or current waves as defined by ANSI Standard C84.1-1989, in accordance with IEEE Standard 519, or any applicable superseding electric industry standard. In the event of a conflict between ANSI Standard C84.1-1989, or any applicable superseding electric industry standard, ANSI Standard C84.1-1989, or the applicable superseding electric industry standard, shall control.

8.79.7 Switching and Tagging Rules.

~~The Developer and Connecting Transmission Owner~~NYSEG and TrAILCo shall each provide the other Party a copy of its switching and tagging rules that are applicable to the other Party's activities. Such switching and tagging rules shall be developed on a nondiscriminatory basis. The Parties shall comply with applicable switching and tagging rules, as amended from time to time, in obtaining clearances for work or for switching operations on equipment.

~~2.10 — Use of Attachment Facilities by Third Parties.~~

~~2.10.1 — Purpose of Attachment Facilities.~~

~~Except as may be required by Applicable Laws and Regulations, or as otherwise agreed to among the Parties, the Attachment Facilities shall be constructed for the sole purpose of interconnecting the Large Generating Facility to the New York State Transmission System and shall be used for no other purpose.~~

8.89.8 [Reserved]

~~2.10.2 — Third Party Users.~~

~~If required by Applicable Laws and Regulations or if the Parties mutually agree, such agreement not to be unreasonably withheld, to allow one or more third parties to use the Connecting Transmission Owner's Attachment Facilities, or any part thereof, Developer will be~~

~~entitled to compensation for the capital expenses it incurred in connection with the Attachment Facilities based upon the pro rata use of the Attachment Facilities by Connecting Transmission Owner, all third party users, and Developer, in accordance with Applicable Laws and Regulations or upon some other mutually agreed upon methodology. In addition, cost responsibility for ongoing costs, including operation and maintenance costs associated with the Attachment Facilities, will be allocated between Developer and any third party users based upon the pro rata use of the Attachment Facilities by Connecting Transmission Owner, all third party users, and Developer, in accordance with Applicable Laws and Regulations or upon some other mutually agreed upon methodology. If the issue of such compensation or allocation cannot be resolved through such negotiations, it shall be submitted to FERC for resolution.~~

8.99.9 Disturbance Analysis Data Exchange.

The Parties will cooperate with one another and the NYISO in the analysis of disturbances to either the ~~Large Generating Facility~~ Mainesburg Substation, the PJM Transmission System, the Watercure Line, or the New York State Transmission System by gathering and providing access to any information relating to any disturbance, including information from disturbance recording equipment, protective relay targets, breaker operations and sequence of events records, and any disturbance information required by Good Utility Practice.

9.10 Emergency Operations

NYSEG shall have the right, including but not limited to after receiving a directive from the NYISO, to direct TrAILCo to take action with regard to breakers at the Mainesburg Substation necessary to disconnect the MHC Segment in order to respond to an Emergency as set forth in Articles 9.10.1 and 9.10.2 below.

9.10.1 NYSEG does not have the right nor the capability to open breakers at the Mainesburg Substation, but rather NYSEG will have the unilateral right to direct TrAILCo to undertake that action with regard to necessary breakers at the Mainesburg Substation to disconnect the MHC Segment based on directives from NYISO or based on conditions or circumstances requiring a response to an Emergency; and

9.10.2 TrAILCo agrees that it shall promptly take the actions specified in a directive issued by NYSEG as indicated in Articles 9.10 and 9.10.1 above in a safe and efficient manner and consistent with Good Utility Practice.

~~ARTICLE 9.~~ARTICLE 10. MAINTENANCE

~~9.10.1~~ 9.10.1 ~~Connecting Transmission Owner~~TrAILCo Obligations.

~~Connecting Transmission Owner~~TrAILCo shall maintain ~~its transmission facilities and Attachment~~the Mainesburg Substation and System Upgrade Facilities owned by TrAILCo in a safe and reliable manner and in accordance with this Agreement.

~~9.210.2~~ 9.210.2 ~~Developer~~NYSEG Obligations.

~~Developer~~NYSEG shall maintain ~~its Large Generating Facility and Attachment~~the Watercure Line and System Upgrade Facilities owned by NYSEG in a safe and reliable manner and in accordance with this Agreement.

~~9.310.3~~ 9.310.3 Coordination.

~~The Developer and Connecting Transmission Owner~~NYSEG and TrAILCo shall confer regularly to coordinate the planning, scheduling and performance of preventive and corrective

maintenance on the ~~Large Generating Facility and the Attachment~~ Mainesburg Substation, Watercure Line, and the System Upgrade Facilities. ~~The Developer and Connecting Transmission Owner~~ NYSEG and TrAILCo shall keep NYISO fully informed of the preventive and corrective maintenance that is planned, and shall schedule all such maintenance in accordance with NYISO procedures.

9.410.4 Secondary Systems.

~~The Developer and Connecting Transmission Owner~~ NYSEG and TrAILCo shall each cooperate with the other in the inspection, maintenance, and testing of control or power circuits that operate below 600 volts, AC or DC, including, but not limited to, any hardware, control or protective devices, cables, conductors, electric raceways, secondary equipment panels, transducers, batteries, chargers, and voltage and current transformers that directly affect the operation of ~~Developer or Connecting Transmission Owner~~ NYSEG or TrAILCo's facilities and equipment which may reasonably be expected to impact the other Party. ~~The Developer and Connecting Transmission Owner~~ NYSEG and TrAILCo shall each provide advance notice to the other Party, and to NYISO, before undertaking any work on such circuits, especially on electrical circuits involving circuit breaker trip and close contacts, current transformers, or potential transformers.

9.510.5 Operating and Maintenance Expenses.

Subject to the provisions herein addressing the use of facilities by others, and except for operations and maintenance expenses associated with modifications made for providing interconnection or transmission service to a third party and such third party pays for such expenses, ~~Developer~~ TrAILCo shall be responsible for all reasonable expenses including

overheads, associated with: ~~(1)~~ owning, operating, maintaining, repairing, and replacing Developer Attachment Facilities; and ~~(2)~~ operation, maintenance, repair and replacement of ~~Connecting Transmission Owner's Attachment~~ its System Upgrade Facilities. ~~The Connecting Transmission Owner~~ NYSEG shall be entitled to the recovery of incremental operating and maintenance expenses that it incurs associated with System Upgrade Facilities ~~and System Deliverability Upgrades~~, if and to the extent provided for under Attachment S to the NYISO OATT.

~~ARTICLE 10.~~ ARTICLE 11. PERFORMANCE OBLIGATION

~~2.11~~ Developer Attachment Facilities.

~~Developer shall design, procure, construct, install, own and/or control the Developer Attachment Facilities described in Appendix A hereto, at its sole expense.~~

~~2.12~~ Connecting Transmission Owner's Attachment Facilities.

~~Connecting Transmission Owner shall design, procure, construct, install, own and/or control the Connecting Transmission Owner's Attachment Facilities described in Appendix A hereto, at the sole expense of the Developer.~~

~~2.13~~ System Upgrade Facilities and System Deliverability Upgrades.

~~Connecting Transmission Owner shall design, procure, construct, install, and own the System Upgrade Facilities and System Deliverability Upgrades described in Appendix A hereto. The responsibility of the Developer for costs related to System Upgrade Facilities and System Deliverability Upgrades shall be determined in accordance with the provisions of Attachment S to the NYISO OATT.~~

~~2.14~~ Special Provisions for Affected Systems.

~~For the re-payment of amounts advanced to Affected System Operator for System Upgrade Facilities or System Deliverability Upgrades, the Developer and Affected System Operator shall enter into an agreement that provides for such re-payment, but only if responsibility for the cost of such System Upgrade Facilities or System Deliverability Upgrades is not to be allocated in accordance with Attachment S to the NYISO OATT. The agreement~~

shall specify the terms governing payments to be made by the Developer to the Affected System Operator as well as the re-payment by the Affected System Operator.

2.15 ~~Provision of Security.~~

~~At least thirty (30) Calendar Days prior to the commencement of the procurement, installation, or construction of a discrete portion of a Connecting Transmission Owner's Attachment Facilities, Developer shall provide Connecting Transmission Owner, at Developer's option, a guarantee, a surety bond, letter of credit or other form of security that is reasonably acceptable to Connecting Transmission Owner and is consistent with the Uniform Commercial Code of the jurisdiction identified in Article 14.2.1 of this Agreement. Such security for payment shall be in an amount sufficient to cover the cost for the Developer's share of constructing, procuring and installing the applicable portion of Connecting Transmission Owner's Attachment Facilities, and shall be reduced on a dollar-for-dollar basis for payments made to Connecting Transmission Owner for these purposes.~~

~~In addition:~~

~~**11.5.1**— The guarantee must be made by an entity that meets the commercially reasonable creditworthiness requirements of Connecting Transmission Owner, and contains terms and conditions that guarantee payment of any amount that may be due from Developer, up to an agreed-to maximum amount.~~

~~**11.5.2**— The letter of credit must be issued by a financial institution reasonably acceptable to Connecting Transmission Owner and must specify a reasonable expiration date.~~

~~**11.5.3**— The surety bond must be issued by an insurer reasonably acceptable to Connecting Transmission Owner and must specify a reasonable expiration date.~~

~~**11.5.4**— Attachment S to the NYISO OATT shall govern the Security that Developer provides for System Upgrade Facilities and System Deliverability Upgrades.~~

~~10.1~~**11.1** ~~Developer~~ **Developer Compensation for Emergency Services.**

If, during an Emergency State, ~~the Developer~~[NYSEG](#) provides services at the request or direction of ~~the NYISO or Connecting Transmission Owner, the Developer~~[TrAILCo, NYSEG](#) will be compensated for such services ~~in accordance with the NYISO Services Tariff. If, during an Emergency State, TrAILCo provides services at the request or direction of NYSEG, TrAILCo~~[will be compensated for such services.](#)

~~10.2~~**11.2** ~~Line Outage Costs.~~

Notwithstanding anything in ~~the NYISO OATT~~[Applicable Laws and Regulations](#) to the contrary, ~~the Connecting Transmission Owner~~[NYSEG](#) may propose to recover line outage costs

associated with the installation of ~~Connecting Transmission Owner's Attachment Facilities of TrAILCo System Upgrade Facilities or System Deliverability Upgrades on a case-by-case basis;~~ on a case-by-case basis; provided, however, NYSEG shall not have the right to recover line outage costs from TrAILCo if such line outage costs are caused by NYSEG's Default under this Agreement.

~~ARTICLE 11.~~ ARTICLE 12. INVOICE

~~11.1~~ 12.1 General.

~~The Developer and Connecting Transmission Owner~~ Each Party shall each submit to ~~the other~~ another Party, on a monthly basis, invoices of amounts due for the preceding month, as applicable. Each invoice shall state the month to which the invoice applies and fully describe the services and equipment provided. The ~~Developer and Connecting Transmission Owner~~ Parties may discharge mutual debts and payment obligations due and owing to each other on the same date through netting, in which case all amounts one Party owes to the other Party under this Agreement, including interest payments or credits, shall be netted so that only the net amount remaining due shall be paid by the owing Party. The allocation of any costs, expenses, or charges to a Party under this Agreement shall not in any way limit the right of each Party to collect such costs or charges in rates approved by the appropriate Governmental Authority.

~~2.16~~ Final Invoice.

~~Within six months after completion of the construction of the Connecting Transmission Owner's Attachment Facilities and the System Upgrade Facilities and System Deliverability Upgrades, Connecting Transmission Owner shall provide an invoice of the final cost of the construction of the Connecting Transmission Owner's Attachment Facilities and the System Upgrade Facilities and System Deliverability Upgrades, determined in accordance with Attachment S to the NYISO OATT, and shall set forth such costs in sufficient detail to enable~~

~~Developer to compare the actual costs with the estimates and to ascertain deviations, if any, from the cost estimates. Connecting Transmission Owner shall refund to Developer any amount by which the actual payment by Developer for estimated costs exceeds the actual costs of construction within thirty (30) Calendar Days of the issuance of such final construction invoice.~~

11.212.2 Payment.

Invoices shall be rendered to the paying Party at the address specified in Appendix ~~F~~E hereto. The Party receiving the invoice shall pay the invoice within thirty (30) Calendar Days of receipt. All payments shall be made in immediately available funds payable to the other Party, or by wire transfer to a bank named and account designated by the invoicing Party. Payment of invoices will not constitute a waiver of any rights or claims the paying Party may have under this Agreement.

11.312.3 Disputes.

In the event of a billing dispute between ~~Connecting Transmission Owner and Developer,~~ ~~Connecting Transmission Owner~~the Parties, each Party shall continue to perform under this Agreement ~~as long as Developer: (i) continues to make all payments not in dispute; and (ii) pays to Connecting Transmission Owner or into an independent escrow account the portion of the invoice in dispute, pending resolution of such dispute. If Developer fails to meet these two requirements for continuation of service, then Connecting Transmission Owner may provide notice to Developer of a Default pursuant to~~and such dispute shall be subject to resolution in accordance with Article ~~17~~27. Within thirty (30) Calendar Days after the resolution of the dispute, the Party that owes money to the other Party shall pay the amount due with interest calculated in accord with the methodology set forth in FERC's Regulations at 18 C.F.R. § 35.19a(a)(2)(iii).

~~ARTICLE 12.~~ARTICLE 13. EMERGENCIES

~~12.1~~13.1 Obligations.

~~Each Party~~Subject to Article 9.10, NYSEG shall comply with the Emergency State procedures of NYISO, the ~~applicable~~Applicable Reliability Councils, and Applicable Laws and Regulations, and ~~any emergency procedures agreed to by the NYISO Operating Committee.~~(b) TrAILCo shall comply with the Emergency State procedures of PJM, the applicable Reliability Councils, and Applicable Laws and Regulations. TrAILCo and NYSEG agree to coordinate with NYISO and PJM to develop procedures that will address the operations of the Watercure Line and the Mainesburg Substation during emergency conditions.

~~12.2~~13.2 Notice.

~~NYISO or, as applicable, Connecting Transmission Owner~~Each Party shall notify ~~Developer~~the other Parties promptly when it becomes aware of an Emergency or Emergency State that affects ~~the Connecting Transmission Owner's Attachment Facilities or the New York State Transmission System that,~~ or may reasonably be expected to affect ~~Developer's operation of the Large Generating Facility or the Developer's Attachment Facilities. Developer shall notify NYISO and Connecting Transmission Owner promptly when it becomes aware of an Emergency State that affects the Large Generating Facility or the Developer Attachment Facilities that may reasonably be expected to affect,~~ the Transmission Facility, the Watercure Line, the System Upgrade Facilities, the New York State Transmission System, or the ConnectingPJM Transmission ~~Owner's Attachment Facilities~~System. To the extent information is known, the notification shall describe the Emergency or Emergency State, the extent of the damage or deficiency, the expected effect on the operation of ~~Developer~~NYSEG's or ~~Connecting~~

~~Transmission Owner~~ TrAILCo's facilities and operations, its anticipated duration and the corrective action taken and/or to be taken. The initial notice shall be followed as soon as practicable with written notice.

~~12.3~~ 13.3 **Immediate Action.**

~~Unless, in Developer's reasonable judgment, immediate action is required, Developer shall obtain the consent of Connecting Transmission Owner, such consent to not be unreasonably withheld, prior to performing any manual switching operations at the Large Generating Facility or the Developer Attachment Facilities in response to an Emergency State either declared by NYISO, Connecting Transmission Owner or otherwise regarding New York State Transmission System.~~

Subject to Article 9.10, or unless, in NYSEG's reasonable judgment, immediate action is required, NYSEG shall obtain the consent of TrAILCo, such consent to not be unreasonably withheld, or delayed, prior to performing any manual switching operations at the Watercure Line or Systems Upgrade Facilities owned by NYSEG in response to an Emergency or Emergency State either declared by NYISO, TrAILCo or otherwise regarding New York State Transmission System. Unless, in TrAILCo's reasonable judgment, immediate action is required, TrAILCo shall obtain the consent of NYSEG, such consent not to be unreasonably withheld, prior to performing any manual switching operations at the TrAILCo System Upgrade Facilities in response to an Emergency or Emergency State either declared by PJM, or TrAILCo, or otherwise regarding the PJM Transmission System.

~~12.4~~ 13.4 **~~NYISO and Connecting Transmission Owner Authority~~ TrAILCo and NYSEG Authority.**

~~2.16.1~~ **General.**

~~NYISO or Connecting Transmission Owner~~ Subject to Article 9.10 and consistent with Good Utility Practice, TrAILCo or NYSEG, as the case may be, may take whatever actions with

regard to the New York State Transmission System ~~or, the Connecting~~ PJM Transmission Owner's Attachment System, and the System Upgrade Facilities owned by that Party, as it deems necessary during an Emergency or Emergency State in order to: (i) preserve public health and safety; (ii) preserve the reliability of the PJM Transmission System and the New York State Transmission System ~~or the Connecting Transmission Owner's Attachment Facilities, as~~ applicable; (iii) limit or prevent damage; and (iv) expedite restoration of service. NYSEG and TrAILCo shall use Reasonable Efforts to assist the other in such actions.

~~NYISO and Connecting Transmission Owner shall use Reasonable Efforts to minimize the effect of such actions or inactions on the Large Generating Facility or the Developer Attachment Facilities. NYISO or Connecting Transmission Owner may, on the basis of technical considerations, require the Large Generating Facility to mitigate an Emergency State by taking actions necessary and limited in scope to remedy the Emergency State, including, but not limited to, directing Developer to shut down, start-up, increase or decrease the real or reactive power output of the Large Generating Facility; implementing a reduction or disconnection pursuant to Article 13.4.2; directing the Developer to assist with blackstart (if available) or restoration efforts; or altering the outage schedules of the Large Generating Facility and the Developer Attachment Facilities. Developer shall comply with all of the NYISO and Connecting Transmission Owner's operating instructions concerning Large Generating Facility real power and reactive power output within the manufacturer's design limitations of the Large Generating Facility's equipment that is in service and physically available for operation at the time, in compliance with Applicable Laws and Regulations.~~

~~2.16.2~~ **Reduction and Disconnection.**

~~NYISO or Connecting Transmission Owner may reduce [] Interconnection Service or disconnect the Large Generating Facility or the Developer Attachment Facilities, when such reduction or disconnection is necessary under Good Utility Practice due to an Emergency State. These rights are separate and distinct from any right of Curtailment of NYISO pursuant to the NYISO OATT. When NYISO or Connecting Transmission Owner can schedule the reduction or disconnection in advance, NYISO or Connecting Transmission Owner shall notify Developer of the reasons, timing and expected duration of the reduction or disconnection. NYISO or Connecting Transmission Owner shall coordinate with the Developer using Good Utility Practice to schedule the reduction or disconnection during periods of least impact to the Developer and the New York State Transmission System. Any reduction or disconnection shall continue only for so long as reasonably necessary under Good Utility Practice. The Parties shall cooperate with each other to restore the Large Generating Facility, the Attachment Facilities, and the New York State~~

~~Transmission System to their normal operating state as soon as practicable consistent with Good Utility Practice.~~

~~2.17~~ **Developer Authority.**

~~Consistent with Good Utility Practice and this Agreement, the Developer may take whatever actions or inactions with regard to the Large Generating Facility or the Developer Attachment Facilities during an Emergency State in order to (i) preserve public health and safety, (ii) preserve the reliability of the Large Generating Facility or the Developer Attachment Facilities, (iii) limit or prevent damage, and (iv) expedite restoration of service. Developer shall use Reasonable Efforts to minimize the effect of such actions or inactions on the New York State Transmission System and the Connecting Transmission Owner's Attachment Facilities. NYISO and Connecting Transmission Owner shall use Reasonable Efforts to assist Developer in such actions.~~

~~12.5~~ **13.5 Limited Liability.**

~~Except as otherwise provided in Article 11.6 of this Agreement, no~~ No Party shall be liable to ~~another~~ any other Party for any action it takes in responding to an Emergency or Emergency State so long as such action is made in good faith and is consistent with Good Utility Practice ~~and the NYISO Tariffs.~~

ARTICLE 14. REGULATORY REQUIREMENTS AND GOVERNING LAW

~~12.6~~ **14.1 Regulatory Requirements.**

Each Party's obligations under this Agreement shall be subject to its receipt of any required approval or certificate from one or more Governmental Authorities in the form and substance satisfactory to the applying Party, or the Party making any required filings with, or providing notice to, such Governmental Authorities, and the expiration of any time period associated therewith. Each Party shall in good faith seek and use its Reasonable Efforts to obtain such other approvals. Nothing in this Agreement shall require ~~Developer~~ TrAILCo or NYSEG to take any action that could result in its inability to obtain, or its loss of, status or exemption under

the Federal Power Act ~~or~~, the Public Utility Holding Company Act of 2005 or the Public Utility Regulatory Policies Act of 1978, as amended.

~~12.7~~14.2 **Governing Law.**

~~12.7.1~~14.2.1 The validity, interpretation and performance of this Agreement and each of its provisions shall be governed by the laws of the ~~state~~State of New York, without regard to its conflicts of law principles.

~~12.7.2~~14.2.2 This Agreement is subject to all Applicable Laws and Regulations.

~~12.7.3~~14.2.3 Each Party expressly reserves the right to seek changes in, appeal, or otherwise contest any ~~laws~~law, orders, rules, or regulations of a Governmental Authority.

~~ARTICLE 13.~~ARTICLE 15. **NOTICES**

~~13.1~~15.1 **General.**

Unless otherwise provided in this Agreement, any notice, demand or request required or permitted to be given by a Party to the other Parties and any instrument required or permitted to be tendered or delivered by a Party in writing to the other Parties shall be effective when delivered and may be so given, tendered or delivered, by recognized national courier, or by depositing the same with the United States Postal Service with postage prepaid, for delivery by certified or registered mail, addressed to the Party, or personally delivered to the Party, at the address set out in Appendix ~~FE~~FE hereto.

A Party may change the notice information in this Agreement by giving five (5) Business Days written notice prior to the effective date of the change.

~~13.2~~15.2 **Billings and Payments.**

Billings and payments shall be sent to the addresses set out in Appendix ~~FE~~ hereto.

~~13.3~~15.3 **Alternative Forms of Notice.**

Any notice or request required or permitted to be given by a Party to the other Parties and not required by this Agreement to be given in writing may be so given by telephone, facsimile or email to the telephone numbers and email addresses set out in Appendix ~~FE~~ hereto.

~~13.4~~15.4 **Operations and Maintenance Notice.**

~~Developer and Connecting Transmission Owner~~NYSEG and TrAILCo shall each notify the other Party, and NYISO, in writing of the identity of the person(s) that it designates as the point(s) of contact with respect to the implementation of Articles 9 and 10 of this Agreement.

~~ARTICLE 14.~~ARTICLE 16. **FORCE MAJEURE**

~~14.1~~16.1 **Force Majeure.**

~~14.1.1~~16.1.1 Economic hardship is not considered a Force Majeure event.

~~14.1.2~~16.1.2 ~~16.1.2~~ A Party shall not be responsible or liable, or deemed, in Default with respect to any obligation hereunder, (including obligations under Article 4 of this Agreement) , other than the obligation to pay money when due, to the extent the Party is prevented from fulfilling such obligation by Force Majeure. A Party unable to fulfill any obligation hereunder (other than an obligation to pay money when due) by reason of Force Majeure shall give notice and the full particulars of such Force Majeure to the other Parties in writing or by telephone as soon as reasonably possible after the occurrence of the cause relied upon. Telephone notices given pursuant to this Article shall be confirmed in writing as soon as

reasonably possible and shall specifically state full particulars of the Force Majeure, the time and date when the Force Majeure occurred and when the Force Majeure is reasonably expected to cease. The Party affected shall exercise due diligence to remove such disability with reasonable dispatch, but shall not be required to accede or agree to any provision not satisfactory to it in order to settle and terminate a strike or other labor disturbance.

~~ARTICLE 15.~~ARTICLE 17. **DEFAULT**

~~15.1~~17.1 **Default.**

~~15.1.1~~17.1.1 **General.**

No Breach shall exist where such failure to discharge an obligation (other than the payment of money) is the result of Force Majeure as defined in this Agreement or the result of an act or omission of the other Parties. Upon a Breach, the non-Breaching Parties shall give written notice of such to the Breaching Party. The Breaching Party shall have thirty (30) Calendar Days from receipt of the Breach notice within which to cure such Breach; provided however, if such Breach is not capable of cure within thirty (30) Calendar Days, the Breaching Party shall commence such cure within thirty (30) Calendar Days after notice and continuously and diligently complete such cure within ninety (90) Calendar Days from receipt of the Breach notice; and, if cured within such time, the Breach specified in such notice shall cease to exist.

~~15.1.2~~17.1.2 **Right to Terminate.**

If a Breach is not cured as provided in this Article 17, or if a Breach is not capable of being cured within the period provided for herein, the non-Breaching Parties acting together shall thereafter have the right to declare a Default and terminate this Agreement by written notice at

any time until cure occurs, and be relieved of any further obligation hereunder and, whether or not those Parties terminate this Agreement, to recover from the defaulting Party all amounts due hereunder, plus all other damages and remedies to which they are entitled at law or in equity.

The provisions of this Article will survive termination of this Agreement.

~~Article 3.— INDEMNITY, CONSEQUENTIAL DAMAGES AND INSURANCE~~

ARTICLE 18. INDEMNITY, LIMITATION OF LIABILITY, AND INSURANCE

15.218.1 Indemnity.

~~Each Party~~Except as provided in Appendix C, NYSEG or TrAILCo (the “Indemnifying Party”) shall at all times indemnify, defend, and save harmless, as applicable, the other Parties (each an “Indemnified Party”) from, any and all ~~damages, losses, claims, including claims and actions relating to injury to or death of any person or damage to property, the alleged violation of any Environmental Law, or the release or threatened release of any Hazardous Substance, demand, suits, recoveries, costs and expenses, court costs, attorney fees, and all other obligations by or to third parties,~~Losses arising out of or resulting from (i) the ~~Indemnified~~Indemnifying’s Party’s ~~performance of its obligations~~Breach, negligence, or intentional wrongdoing under this Agreement ~~on behalf of the Indemnifying Party~~, except in cases where the Indemnifying Party can demonstrate that the Loss of the Indemnified Party was caused (in whole or in part) by the gross negligence or intentional wrongdoing of the Indemnified Party or (ii) the violation by the Indemnifying Party of any Environmental Law or the release by the Indemnifying Party of any Hazardous Substance. TrAILCo shall provide an additional, independent indemnity to NYSEG in accordance with the provisions of Section C(10) of Appendix C, and any conflict between that

provision of Appendix C and this Article 18 shall be resolved in favor of Section C(10) of Appendix C.

~~15.2.1~~18.1.1 Indemnified Party.

If a Party is entitled to indemnification under this Article 18 as a result of a claim by a third party, and the indemnifying Party fails, after notice and reasonable opportunity to proceed under Article 18.1.3, to assume the defense of such claim, such Indemnified Party may at the expense of the Indemnifying Party contest, settle or consent to the entry of any judgment with respect to, or pay in full, such claim.

~~15.2.2~~18.1.2 Indemnifying Party.

If an Indemnifying Party is obligated to indemnify and hold any Indemnified Party harmless under this Article 18, the amount owing to the Indemnified Party shall be the amount of such Indemnified Party's actual Loss, net of any insurance or other recovery.

~~15.2.3~~18.1.3 Indemnity Procedures.

Promptly after receipt by an Indemnified Party of any claim or notice of the commencement of any action or administrative or legal proceeding or investigation as to which the indemnity provided for in Article 18.1 may apply, the Indemnified Party shall notify the Indemnifying Party of such fact. Any failure of or delay in such notification shall not affect a Party's indemnification obligation unless such failure or delay is materially prejudicial to the Indemnifying Party.

Except as stated below, the Indemnifying Party shall have the right to assume the defense thereof with counsel designated by such Indemnifying Party and reasonably satisfactory to the

Indemnified Party. If the defendants in any such action include one or more Indemnified Parties and the Indemnifying Party and if the Indemnified Party reasonably concludes that there may be legal defenses available to it and/or other Indemnified Parties which are different from or additional to those available to the Indemnifying Party, the Indemnified Party shall have the right to select separate counsel to assert such legal defenses and to otherwise participate in the defense of such action on its own behalf. In such instances, the Indemnifying Party shall only be required to pay the fees and expenses of one additional attorney to represent an Indemnified Party or Indemnified Parties having such differing or additional legal defenses.

The Indemnified Party shall be entitled, at its expense, to participate in any such action, suit or proceeding, the defense of which has been assumed by the Indemnifying Party. Notwithstanding the foregoing, the Indemnifying Party (i) shall not be entitled to assume and control the defense of any such action, suit or proceedings if and to the extent that, in the opinion of the Indemnified Party and its counsel, such action, suit or proceeding involves the potential imposition of criminal liability on the Indemnified Party, or there exists a conflict or adversity of interest between the Indemnified Party and the Indemnifying Party, in such event the Indemnifying Party shall pay the reasonable expenses of the Indemnified Party, and (ii) shall not settle or consent to the entry of any judgment in any action, suit or proceeding without the consent of the Indemnified Party, which shall not be unreasonably withheld, conditioned or delayed.

~~15.3~~18.2 ~~No Consequential Damages~~ Limitation of Liability.

~~15.3.1~~18.2.1 Other than the ~~Liquidated Damages heretofore described and the~~ indemnity obligations set forth in Article ~~18.1~~18.1, in no event shall any Party be liable under

any provision of this Agreement for any losses, damages, costs or expenses for any special, indirect, incidental, consequential, or punitive damages, including but not limited to loss of profit or revenue, loss of the use of equipment, cost of capital, cost of temporary equipment or services, whether based in whole or in part in contract, in tort, including negligence, strict liability, or any other theory of liability; provided, however, that damages for which a Party may be liable to another Party under separate agreement will not be considered to be special, indirect, incidental, or consequential damages hereunder. The Parties expressly agree the damages that NYSEG may seek to recover pursuant to Appendix C shall not be considered special, indirect, incidental, consequential, or punitive damages whose recovery is limited by this Article 18.2.1.

18.2.2 Nothing in this Agreement shall be construed to create or give rise to any liability on the part of PJM, and the Parties expressly waive any claims that may arise against PJM under this Agreement.

18.2.3 The Parties acknowledge and understand that the signature of the authorized officer of PJM on this Agreement is for the limited purpose of acknowledging that representatives of PJM have read the terms of this Agreement. The Parties and PJM further state that they understand that FERC desires that the Parties keep PJM fully apprised of the matters addressed herein as well as any reliability and planning issues that may arise under this Agreement, and that the signature of the PJM officer shall not in any way be deemed to imply that PJM is taking responsibility for the actions of any Party, that PJM has any affirmative duties under this Agreement or that PJM is liable in any way under this Agreement.

~~15.4~~18.3 **Insurance.**

~~Developer and Connecting Transmission Owner~~NYSEG and TrAILCo shall each, at its own expense, maintain in force throughout the period of this Agreement, and until released by the other Parties, the following minimum insurance coverages, with insurers authorized to do business in the state of New York:

~~15.4.1~~18.3.1 Employers' Liability and Workers' Compensation Insurance providing statutory benefits in accordance with the laws and regulations of New York State.

~~15.4.2~~18.3.2 Commercial General Liability Insurance including premises and operations, personal injury, broad form property damage, broad form blanket contractual liability coverage (including coverage for the contractual indemnification) products and completed operations coverage, coverage for explosion, collapse and underground hazards, independent

contractors coverage, coverage for pollution to the extent normally available and punitive damages to the extent normally available and a cross liability endorsement, with minimum limits of One Million Dollars (\$1,000,000) per occurrence/One Million Dollars (\$1,000,000) aggregate combined single limit for personal injury, bodily injury, including death and property damage.

~~15.4.3~~18.3.3 Comprehensive Automobile Liability Insurance for coverage of owned and non-owned and hired vehicles, trailers or semi-trailers designed for travel on public roads, with a minimum, combined single limit of One Million Dollars (\$1,000,000) per occurrence for bodily injury, including death, and property damage.

~~15.4.4~~18.3.4 Excess Public Liability Insurance over and above the Employers' Liability Commercial General Liability and Comprehensive Automobile Liability Insurance coverage, with a minimum combined single limit of Twenty Million Dollars (\$20,000,000) per occurrence/Twenty Million Dollars (\$20,000,000) aggregate.

~~15.4.5~~18.3.5 The Commercial General Liability Insurance, Comprehensive Automobile Insurance and Excess Public Liability Insurance policies of ~~Developer and Connecting-Transmission Owner~~NYSEG and TrAILCo shall name the other Party, its parent, associated and Affiliate companies and their respective directors, officers, agents, servants and employees ("Other Party Group") as additional insured. All policies shall contain provisions whereby the insurers waive all rights of subrogation in accordance with the provisions of this Agreement against the Other Party Group and provide thirty (30) Calendar days advance written notice to the Other Party Group prior to anniversary date of cancellation or any material change in coverage or condition.

~~15.4.6~~18.3.6 The Commercial General Liability Insurance, Comprehensive Automobile Liability Insurance and Excess Public Liability Insurance policies shall contain provisions that specify that the policies are primary and shall apply to such extent without consideration for other policies separately carried and shall state that each insured is provided coverage as though a separate policy had been issued to each, except the insurer's liability shall not be increased beyond the amount for which the insurer would have been liable had only one insured been covered. ~~Developer and Connecting Transmission Owner~~NYSEG and TrAILCo shall each be responsible for its respective deductibles or retentions.

~~15.4.7~~18.3.7 The Commercial General Liability Insurance, Comprehensive Automobile Liability Insurance and Excess Public Liability Insurance policies, if written on a Claims First Made Basis, shall be maintained in full force and effect for two (2) years after termination of this Agreement, which coverage may be in the form of tail coverage or extended reporting period coverage if agreed by ~~the Developer and Connecting Transmission Owner~~NYSEG and TrAILCo.

~~15.4.8~~18.3.8 The requirements contained herein as to the types and limits of all insurance to be maintained by ~~the Developer and Connecting Transmission Owner~~NYSEG and TrAILCo are not intended to and shall not in any manner, limit or qualify the liabilities and obligations assumed by those Parties under this Agreement.

~~15.4.9~~18.3.9 Within ten (10) days following execution of this Agreement, and as soon as practicable after the end of each fiscal year or at the renewal of the insurance policy and in any event within ninety (90) days thereafter, ~~Developer and Connecting Transmission Owner~~NYSEG and TrAILCo shall provide certification of all insurance required in this

Agreement, executed by each insurer or by an authorized representative of each insurer.

~~15.4.10~~18.3.10 Notwithstanding the foregoing, ~~Developer and Connecting Transmission Owner~~NYSEG and TrAILCo may each self-insure to meet the minimum insurance requirements of Articles 18.3.2 through 18.3.8 to the extent it maintains a self-insurance program; provided that, such Party's senior debt is rated at investment grade, or better, by Standard & Poor's and that its self-insurance program meets the minimum insurance requirements of Articles 18.3.2 through 18.3.8. For any period of time that a Party's senior debt is unrated by Standard & Poor's or is rated at less than investment grade by Standard & Poor's, such Party shall comply with the insurance requirements applicable to it under Articles 18.3.2 through 18.3.9. In the event that a Party is permitted to self-insure pursuant to this Article 18.3.10, it shall notify the other Party that it meets the requirements to self-insure and that its self-insurance program meets the minimum insurance requirements in a manner consistent with that specified in Article 18.3.9.

~~15.4.11~~18.3.11 ~~Developer and Connecting Transmission Owner~~NYSEG and TrAILCo agree to report to each other in writing as soon as practical all accidents or occurrences resulting in injuries to any person, including death, and any property damage arising out of this Agreement.

~~ARTICLE 16.~~ARTICLE 19. ASSIGNMENT

~~16.1~~19.1 Assignment.

This Agreement may be assigned by a Party only with the written consent of the other ~~Parties~~Party; provided that a Party may assign this Agreement without the consent of the other

~~Parties~~Party to any Affiliate of the assigning Party with an equal or greater credit rating and with the legal authority and operational ability to satisfy the obligations of the assigning Party under this Agreement; provided further that a Party may assign this Agreement without the consent of the other ~~Parties~~Party in connection with the sale, merger, restructuring, or transfer of a substantial portion or all of its assets, ~~including the Attachment Facilities it owns,~~ so long as the assignee in such a transaction directly assumes in writing all rights, duties and obligations arising under this Agreement; ~~and provided further that the Developer shall have the right to assign this Agreement, without the consent of the NYISO or Connecting Transmission Owner, for collateral security purposes to aid in providing financing for the Large Generating Facility, provided that the Developer will promptly notify the NYISO and Connecting Transmission Owner of any such assignment. Any financing arrangement entered into by the Developer pursuant to this Article will provide that prior to or upon the exercise of the secured party's, trustee's or mortgagee's assignment rights pursuant to said arrangement, the secured creditor, the trustee or mortgagee will notify the NYISO and Connecting Transmission Owner of the date and particulars of any such exercise of assignment right(s) and will provide the NYISO and Connecting Transmission Owner with proof that it meets the requirements of Articles 11.5 and 18.3.~~ Any attempted assignment that violates this Article is void and ineffective. Any assignment under this Agreement shall not relieve a Party of its obligations, nor shall a Party's obligations be enlarged, in whole or in part, by reason thereof. Where required, consent to assignment will not be unreasonably withheld, conditioned or delayed.

~~ARTICLE 17.~~ARTICLE 20. SEVERABILITY

~~17.1~~20.1 Severability.

If any provision in this Agreement is finally determined to be invalid, void or unenforceable by any court or other Governmental Authority having jurisdiction, such determination shall not invalidate, void or make unenforceable any other provision, agreement or covenant of this Agreement; ~~provided that if the Developer (or any third party, but only if such third party is not acting at the direction of the Connecting Transmission Owner) seeks and obtains such a final determination with respect to any provision of the Alternate Option (Article 5.1.2), or the Negotiated Option (Article 5.1.4), then none of these provisions shall thereafter have any force or effect and the rights and obligations of Developer and Connecting Transmission Owner shall be governed solely by the Standard Option (Article 5.1.1).~~

~~ARTICLE 18.~~ARTICLE 21. COMPARABILITY

~~18.1~~21.1 Comparability.

The Parties will comply with all applicable comparability and code of conduct laws, rules and regulations, as amended from time to time.

~~ARTICLE 19.~~ARTICLE 22. CONFIDENTIALITY

~~19.1~~22.1 Confidentiality.

Certain information exchanged by the Parties during the term of this Agreement shall constitute confidential information (“Confidential Information”) and shall be subject to this Article 22.

If requested by a Party receiving information, the Party supplying the information shall provide in writing, the basis for asserting that the information referred to in this Article warrants confidential treatment, and the requesting Party may disclose such writing to the appropriate Governmental Authority. Each Party shall be responsible for the costs associated with affording confidential treatment to its information.

~~19.1.22.1.1~~ 19.1.22.1.1 Term.

During the term of this Agreement, and for a period of three (3) years after the expiration or termination of this Agreement, except as otherwise provided in this Article ~~22.22~~, each Party shall hold in confidence and shall not disclose to any person Confidential Information.

~~19.1.22.1.2~~ 19.1.22.1.2 Confidential Information.

The following shall constitute Confidential Information: (~~1~~a) any non-public information that is treated as confidential by the disclosing Party and which the disclosing Party identifies as Confidential Information in writing at the time, or promptly after the time, of disclosure; or (~~2~~b) information designated as Confidential Information by the NYISO Code of Conduct contained in Attachment F to the NYISO OATT.

~~19.1.322.1.3~~ 19.1.322.1.3 Scope.

Confidential Information shall not include information that the receiving Party can demonstrate: (1) is generally available to the public other than as a result of a disclosure by the receiving Party; (2) was in the lawful possession of the receiving Party on a non-confidential basis before receiving it from the disclosing Party; (3) was supplied to the receiving Party without restriction by a third party, who, to the knowledge of the receiving Party after due

inquiry, was under no obligation to the disclosing Party to keep such information confidential; (4) was independently developed by the receiving Party without reference to Confidential Information of the disclosing Party; (5) is, or becomes, publicly known, through no wrongful act or omission of the receiving Party or Breach of this Agreement; or (6) is required, in accordance with Article 22.1.8 of this Agreement, Order of Disclosure, to be disclosed ~~by any Governmental Authority or is otherwise required to be disclosed by law or subpoena, or is necessary in any legal proceeding establishing rights and obligations under this Agreement.~~ Information designated as Confidential Information will no longer be deemed confidential if the Party that designated the information as confidential notifies the other Party that it no longer is confidential.

19.1.422.1.4 Release of Confidential Information.

No Party shall release or disclose Confidential Information to any other person, except to its Affiliates (limited by FERC Standards of Conduct requirements), subcontractors, employees, consultants, or to parties who may be considering providing financing to or equity participation with ~~Developer~~NYSEG, or to potential purchasers or assignees of a Party, on a need-to-know basis in connection with this Agreement, unless such person has first been advised of the confidentiality provisions of this Article 22 and has agreed to comply with such provisions. Notwithstanding the foregoing, a Party providing Confidential Information to any person shall remain primarily responsible for any release of Confidential Information in contravention of this Article 22.

19.1.522.1.5 Rights.

Each Party retains all rights, title, and interest in the Confidential Information that each Party discloses to the other Party. The disclosure by each Party to the other Parties of Confidential Information shall not be deemed a waiver by any Party or any other person or entity of the right to protect the Confidential Information from public disclosure.

19.1.622.1.6 No Warranties.

By providing Confidential Information, no Party makes any warranties or representations as to its accuracy or completeness. In addition, by supplying Confidential Information, no Party obligates itself to provide any particular information or Confidential Information to the other Parties nor to enter into any further agreements or proceed with any other relationship or joint venture.

19.1.722.1.7 Standard of Care.

Each Party shall use at least the same standard of care to protect Confidential Information it receives as it uses to protect its own Confidential Information from unauthorized disclosure, publication or dissemination. Each Party may use Confidential Information solely to fulfill its obligations to the other Party under this Agreement or its regulatory requirements, including the NYISO OATT and NYISO Services Tariff. The NYISO shall, in all cases, treat the information it receives in accordance with the requirements of Attachment F to the NYISO OATT.

19.1.822.1.8 Order of Disclosure.

If a court or a Government Authority or entity with the right, power, and apparent authority to do so requests or requires any Party, by subpoena, oral deposition, interrogatories,

requests for production of documents, administrative order, or otherwise; to disclose Confidential Information, that Party shall provide the other Parties with prompt notice of such request(s) or requirement(s) so that the other Parties may seek an appropriate protective order or waive compliance with the terms of this Agreement. Notwithstanding the absence of a protective order or waiver, the Party may disclose such Confidential Information which, in the opinion of its counsel, the Party is legally compelled to disclose. Each Party will use Reasonable Efforts to obtain reliable assurance that confidential treatment will be accorded any Confidential Information so furnished.

19.1.922.1.9 Termination of Agreement.

Upon termination of this Agreement for any reason, each Party shall, within ten (10) Calendar Days of receipt of a written request from the other Parties, use Reasonable Efforts to destroy, erase, or delete (with such destruction, erasure, and deletion certified in writing to the other Parties) or return to the other Parties, without retaining copies thereof, any and all written or electronic Confidential Information received from the other Parties pursuant to this Agreement.

19.1.1022.1.10 Remedies.

The Parties agree that monetary damages would be inadequate to compensate a Party for another Party's Breach of its obligations under this Article 22. Each Party accordingly agrees that the other Parties shall be entitled to equitable relief, by way of injunction or otherwise, if the first Party Breaches or threatens to Breach its obligations under this Article 22, which equitable relief shall be granted without bond or proof of damages, and the receiving Party shall not plead in defense that there would be an adequate remedy at law. Such remedy shall not be deemed an

exclusive remedy for the Breach of this Article 22, but shall be in addition to all other remedies available at law or in equity. The Parties further acknowledge and agree that the covenants contained herein are necessary for the protection of legitimate business interests and are reasonable in scope. No Party, however, shall be liable for indirect, incidental, or consequential or punitive damages of any nature or kind resulting from or arising in connection with this Article 22.

19.1.1122.1.11 Disclosure to FERC, its Staff, or a State.

Notwithstanding anything in this Article 22 to the contrary, and pursuant to 18 C.F.R. section 1b.20, if FERC or its staff, during the course of an investigation or otherwise, requests information from one of the Parties that is otherwise required to be maintained in confidence pursuant to this Agreement, or the NYISO OATT, the Party shall provide the requested information to FERC or its staff, within the time provided for in the request for information. In providing the information to FERC or its staff, the Party must, consistent with 18 C.F.R. section 388.112, request that the information be treated as confidential and non-public by FERC and its staff and that the information be withheld from public disclosure. Parties are prohibited from notifying the other Parties to this Agreement prior to the release of the Confidential Information to the Commission or its staff. The Party shall notify the other Parties to the Agreement when it is notified by FERC or its staff that a request to release Confidential Information has been received by FERC, at which time the Parties may respond before such information would be made public, pursuant to 18 C.F.R. section 388.112. Requests from a state regulatory body conducting a confidential investigation shall be treated in a similar manner if consistent with the applicable state rules and regulations. A Party shall not be liable for any losses, consequential or

otherwise, resulting from that Party divulging Confidential Information pursuant to a FERC or state regulatory body request under this paragraph.

~~19.1.12~~22.1.12

Except as otherwise expressly provided herein, no Party shall disclose Confidential Information to any person not employed or retained by the Party possessing the Confidential Information, except to the extent disclosure is: (i) required by law; (ii) reasonably deemed by the disclosing Party to be required to be disclosed in connection with a dispute between or among the Parties, or the defense of litigation or dispute; (iii) otherwise permitted by consent of the other Party, such consent not to be unreasonably withheld; or (iv) necessary to fulfill its obligations under this Agreement, the NYISO OATT ~~or~~on the NYISO Services Tariff. Prior to any disclosures of a Party's Confidential Information under this subparagraph, or if any third party or Governmental Authority makes any request or demand for any of the information described in this subparagraph, the disclosing Party agrees to promptly notify the other Party in writing and agrees to assert confidentiality and cooperate with the other Party in seeking to protect the Confidential Information from public disclosure by confidentiality agreement, protective order or other reasonable measures.

~~ARTICLE 20.~~ARTICLE 23. ENVIRONMENTAL RELEASES

~~20.123.1~~23.1 ~~Developer and Connecting Transmission Owner~~NYSEG and TrAILCo Notice.

~~Developer and Connecting Transmission Owner~~Subject to reporting requirements that may be imposed on NYSEG and TrAILCo under Applicable Laws and Regulations, NYSEG and TrAILCo shall each notify the other Party, first orally and then in writing, of the release of any

Hazardous Substances, any asbestos or lead abatement activities, or any type of remediation activities related to the ~~Large-Generating~~Transmission Facility ~~or the Attachment Facilities~~, each of which may reasonably be expected to affect the other Party. ~~The~~Subject to reporting requirements that may be imposed on NYSEG and TrAILCo under Applicable Laws and Regulations, the notifying Party shall: (i) provide the notice as soon as practicable, provided such Party makes a good faith effort to provide the notice no later than twenty-four hours after such Party becomes aware of the occurrence; and (ii) promptly furnish to the other Party copies of any publicly available reports filed with any Governmental Authorities addressing such events.

~~ARTICLE 21.~~ARTICLE 24. INFORMATION REQUIREMENT~~[Reserved]~~

~~3.1~~ ~~Information Acquisition.~~

~~Connecting Transmission Owner and Developer shall each submit specific information regarding the electrical characteristics of their respective facilities to the other, and to NYISO, as described below and in accordance with Applicable Reliability Standards.~~

~~3.2~~ ~~Information Submission by Connecting Transmission Owner.~~

~~The initial information submission by Connecting Transmission Owner shall occur no later than one hundred eighty (180) Calendar Days prior to Trial Operation and shall include New York State Transmission System information necessary to allow the Developer to select equipment and meet any system protection and stability requirements, unless otherwise mutually agreed to by the Developer and Connecting Transmission Owner. On a monthly basis Connecting Transmission Owner shall provide Developer and NYISO a status report on the construction and installation of Connecting Transmission Owner's Attachment Facilities and System Upgrade Facilities and System Deliverability Upgrades, including, but not limited to, the following information: (1) progress to date; (2) a description of the activities since the last report; (3) a description of the action items for the next period; and (4) the delivery status of equipment ordered.~~

~~3.3~~ Updated Information Submission by Developer.

~~The updated information submission by the Developer, including manufacturer information, shall occur no later than one hundred eighty (180) Calendar Days prior to the Trial Operation. Developer shall submit a completed copy of the Large Generating Facility data requirements contained in Appendix 1 to the Large Facility Interconnection Procedures. It shall also include any additional information provided to Connecting Transmission Owner for the Interconnection Feasibility Study and Interconnection Facilities Study. Information in this submission shall be the most current Large Generating Facility design or expected performance data. Information submitted for stability models shall be compatible with NYISO standard models. If there is no compatible model, the Developer will work with a consultant mutually agreed to by the Parties to develop and supply a standard model and associated information.~~

~~If the Developer's data is different from what was originally provided to Connecting Transmission Owner and NYISO pursuant to an Interconnection Study Agreement among Connecting Transmission Owner, NYISO and Developer and this difference may be reasonably expected to affect the other Parties' facilities or the New York State Transmission System, but does not require the submission of a new Interconnection Request, then NYISO will conduct appropriate studies to determine the impact on the New York State Transmission System based on the actual data submitted pursuant to this Article 24.3. Such studies will provide an estimate of any additional modifications to the New York State Transmission System, Connecting Transmission Owner's Attachment Facilities or System Upgrade Facilities or System Deliverability Upgrades based on the actual data and a good faith estimate of the costs thereof. The Developer shall not begin Trial Operation until such studies are completed. The Developer shall be responsible for the cost of any modifications required by the actual data, including the cost of any required studies.~~

~~3.4~~ Information Supplementation.

~~Prior to the Commercial Operation Date, the Developer and Connecting Transmission Owner shall supplement their information submissions described above in this Article 24 with any and all "as-built" Large Generating Facility information or "as-tested" performance information that differs from the initial submissions or, alternatively, written confirmation that no such differences exist. The Developer shall conduct tests on the Large Generating Facility as required by Good Utility Practice such as an open circuit "step voltage" test on the Large Generating Facility to verify proper operation of the Large Generating Facility's automatic voltage regulator.~~

~~ARTICLE 22.~~ ARTICLE 25. INFORMATION ACCESS AND AUDIT RIGHTS

~~Unless otherwise agreed, the test conditions shall include: (1) Large Generating Facility at synchronous speed; (2) automatic voltage regulator on and in voltage control mode; and (3) a five percent change in Large Generating Facility terminal voltage initiated by a change in the~~

~~voltage regulators reference voltage. Developer shall provide validated test recordings showing the responses of Large Generating Facility terminal and field voltages. In the event that direct recordings of these voltages is impractical, recordings of other voltages or currents that mirror the response of the Large Generating Facility's terminal or field voltage are acceptable if information necessary to translate these alternate quantities to actual Large Generating Facility terminal or field voltages is provided. Large Generating Facility testing shall be conducted and results provided to the Connecting Transmission Owner and NYISO for each individual generating unit in a station.~~

~~Subsequent to the Commercial Operation Date, the Developer shall provide Connecting Transmission Owner and NYISO any information changes due to equipment replacement, repair, or adjustment. Connecting Transmission Owner shall provide the Developer and NYISO any information changes due to equipment replacement, repair or adjustment in the directly connected substation or any adjacent Connecting Transmission Owner substation that may affect the Developer Attachment Facilities equipment ratings, protection or operating requirements. The Developer and Connecting Transmission Owner shall provide such information no later than thirty (30) Calendar Days after the date of the equipment replacement, repair or adjustment.~~

~~22.1~~25.1 **Information Access.**

Each Party (“Disclosing Party”) shall make available to another Party (“Requesting Party”) information that is in the possession of the Disclosing Party and is necessary in order for the Requesting Party to: (i) verify the costs incurred by the Disclosing Party for which the Requesting Party is responsible under this Agreement; and (ii) carry out its obligations and responsibilities under this Agreement. The Parties shall not use such information for purposes other than those set forth in this Article 25.1 of this Agreement and to enforce their rights under this Agreement.

~~22.2~~25.2 **Reporting of Non-Force Majeure Events.**

Each Party (the “Notifying Party”) shall notify the other Parties when the Notifying Party becomes aware of its inability to comply with the provisions of this Agreement for a reason other than a Force Majeure event. The Parties agree to cooperate with each other and provide necessary information regarding such inability to comply, including the date, duration, reason for the inability to comply, and corrective actions taken or planned to be taken with respect to such

inability to comply. Notwithstanding the foregoing, notification, cooperation or information provided under this Article shall not entitle the Party receiving such notification to allege a cause for anticipatory breach of this Agreement.

~~22.3~~25.3 **Audit Rights.**

Subject to the requirements of confidentiality under Article 22 of this Agreement, each Party shall have the right, during normal business hours, and upon prior reasonable notice to ~~another Party~~the other Parties, to audit at its own expense the other Party's accounts and records pertaining to the other Party's performance or satisfaction of its obligations under this Agreement. Such audit rights shall include audits of the other Party's costs, calculation of invoiced amounts, and each Party's actions in an Emergency or Emergency State. Any audit authorized by this Article shall be performed at the offices where such accounts and records are maintained and shall be limited to those portions of such accounts and records that relate to the Party's performance and satisfaction of obligations under this Agreement. Each Party shall keep such accounts and records for a period equivalent to the audit rights periods described in Article 25.4 of this Agreement.

~~22.4~~25.4 **Audit Rights Periods.**

~~22.4.1~~25.4.1 **Audit Rights Period for Construction-Related Accounts and Records.**

Accounts and records related to the design, engineering, procurement, and construction of ~~Connecting Transmission Owner's Attachment Facilities and~~ System Upgrade Facilities ~~and~~ ~~System Deliverability Upgrades~~ shall be subject to audit for a period of twenty-four months

following ~~Connecting Transmission Owner's issuance of a final invoice in accordance with Article 12.2 of this Agreement~~ the Commercial Operation Date.

~~22.4.~~25.4.2 **Audit Rights Period for All Other Accounts and Records.**

Accounts and records related to a Party's performance or satisfaction of its obligations under this Agreement other than those described in Article 25.4.1 of this Agreement shall be subject to audit as follows: (i) for an audit relating to cost obligations, the applicable audit rights period shall be twenty-four months after the auditing Party's receipt of an invoice giving rise to such cost obligations; and (ii) for an audit relating to all other obligations, the applicable audit rights period shall be twenty-four months after the event for which the audit is sought.

~~22.5.~~25.5 **Audit Results.**

If an audit by a Party determines that an overpayment or an underpayment has occurred, a notice of such overpayment or underpayment shall be given to the other Party together with those records from the audit which support such determination.

~~ARTICLE 23.~~ARTICLE 26. **SUBCONTRACTORS**

~~23.1.~~26.1 **General.**

Nothing in this Agreement shall prevent a Party from utilizing the services of any subcontractor as it deems appropriate to perform its obligations under this Agreement; provided, however, that each Party shall require its subcontractors to comply with all applicable terms and conditions of this Agreement in providing such services and each Party shall remain primarily liable to the other ~~Parties~~Party for the performance of such subcontractor.

~~23.2~~26.2 **Responsibility of Principal.**

The creation of any subcontract relationship shall not relieve the hiring Party of any of its obligations under this Agreement. The hiring Party shall be fully responsible to the other ~~Parties~~Party for the acts or omissions of any subcontractor the hiring Party hires as if no subcontract had been made; provided, however, that in no event shall ~~the~~NYSEG or NYISO or ~~Connecting Transmission Owner~~ be liable for the actions or inactions of ~~the Developer~~TrAILCo or its subcontractors with respect to obligations of ~~the Developer~~TrAILCo under Article 5 of this Agreement. Any applicable obligation imposed by this Agreement upon the hiring Party shall be equally binding upon, and shall be construed as having application to, any subcontractor of such Party.

~~23.3~~26.3 **No Limitation by Insurance.**

The obligations under this Article 26 will not be limited in any way by any limitation of subcontractor's insurance.

~~ARTICLE 24.~~ARTICLE 27. **DISPUTES**

~~24.1~~27.1 **Submission.**

In the event any Party has a dispute, or asserts a claim, that arises out of or in connection with this Agreement or its performance (a "Dispute"), such Party shall provide the other Parties with written notice of the Dispute ("Notice of Dispute"). Such Dispute shall be referred to a designated senior representative of each Party for resolution on an informal basis as promptly as practicable after receipt of the Notice of Dispute by the other ~~Parties~~Party. In the event the designated representatives are unable to resolve the Dispute through unassisted or assisted

negotiations within thirty (30) Calendar Days of the other Parties' receipt of the Notice of Dispute, such Dispute may, upon mutual agreement of the Parties, be submitted to arbitration and resolved in accordance with the arbitration procedures set forth below. In the event the Parties do not agree to submit such Dispute to arbitration, each Party may exercise whatever rights and remedies it may have in equity or at law consistent with the terms of this Agreement.

24.227.2 External Arbitration Procedures.

Any arbitration initiated under this Agreement shall be conducted before a single neutral arbitrator appointed by the Parties. If the Parties fail to agree upon a single arbitrator within ten (10) Calendar Days of the submission of the Dispute to arbitration, each Party shall choose one arbitrator who shall sit on a three-member arbitration panel. In each case, the arbitrator(s) shall be knowledgeable in electric utility matters, including electric transmission and bulk power issues, and shall not have any current or past substantial business or financial relationships with any party to the arbitration (except prior arbitration). The arbitrator(s) shall provide each of the Parties an opportunity to be heard and, except as otherwise provided herein, shall conduct the arbitration in accordance with the Commercial Arbitration Rules of the American Arbitration Association ("Arbitration Rules") and any applicable FERC regulations or RTO rules; provided, however, in the event of a conflict between the Arbitration Rules and the terms of this Article 27, the terms of this Article 27 shall prevail.

24.327.3 Arbitration Decisions.

Unless otherwise agreed by the Parties, the arbitrator(s) shall render a decision within ninety (90) Calendar Days of appointment and shall notify the Parties in writing of such decision and the reasons therefor. The arbitrator(s) shall be authorized only to interpret and apply the

provisions of this Agreement and shall have no power to modify or change any provision of this Agreement in any manner. The decision of the arbitrator(s) shall be final and binding upon the Parties, and judgment on the award may be entered in any court having jurisdiction. The decision of the arbitrator(s) may be appealed solely on the grounds that the conduct of the arbitrator(s), or the decision itself, violated the standards set forth in the Federal Arbitration Act or the Administrative Dispute Resolution Act. The final decision of the arbitrator must also be filed with FERC if it affects jurisdictional rates, terms and conditions of service, ~~Attachment Facilities~~, or System Upgrade Facilities, ~~System Deliverability Upgrades~~.

~~24.4~~27.4 **Costs.**

Each Party shall be responsible for its own costs incurred during the arbitration process and for the following costs, if applicable: (1) the cost of the arbitrator chosen by the Party to sit on the three member panel; or (2) one-third the cost of the single arbitrator jointly chosen by the Parties.

~~24.5~~27.5 **Termination.**

Notwithstanding the provisions of this Article 27, any Party may terminate this Agreement in accordance with its provisions or pursuant to an action at law or equity. The issue of whether such a termination is proper shall not be considered a Dispute hereunder.

~~Article 4.~~

ARTICLE 28. **REPRESENTATIONS, WARRANTIES AND COVENANTS**

~~24.6~~28.1 **General.**

Each Party makes the following representations, warranties and covenants:

24.6.128.1.1 Good Standing.

Such Party is duly organized, validly existing and in good standing under the laws of the state in which it is organized, formed, or incorporated, as applicable; that it is qualified to do business in the state or states in which the ~~Large Generating~~Transmission Facility, ~~Attachment Facilities~~ and System Upgrade Facilities ~~and System Deliverability Upgrades~~, owned by such Party, as applicable, are located; and that it has the corporate power and authority to own its properties, to carry on its business as now being conducted and to enter into this Agreement and carry out the transactions contemplated hereby and perform and carry out all covenants and obligations on its part to be performed under and pursuant to this Agreement.

24.6.228.1.2 Authority.

Such Party has the right, power and authority to enter into this Agreement, to become a Party hereto and to perform its obligations hereunder. This Agreement is a legal, valid and binding obligation of such Party, enforceable against such Party in accordance with its terms, except as the enforceability thereof may be limited by applicable bankruptcy, insolvency, reorganization or other similar laws affecting creditors' rights generally and by general equitable principles (regardless of whether enforceability is sought in a proceeding in equity or at law).

24.6.328.1.3 No Conflict.

The execution, delivery and performance of this Agreement does not violate or conflict with the organizational or formation documents, or bylaws or operating agreement, of such Party, or any judgment, license, permit, order, material agreement or instrument applicable to or binding upon such Party or any of its assets.

~~24.6.428.1.4~~ 28.1.4 Consent and Approval.

Such Party has sought or obtained, or, in accordance with this Agreement will seek or obtain, each consent, approval, authorization, order, or acceptance by any Governmental Authority in connection with the execution, delivery and performance of this Agreement, and it will provide to any Governmental Authority notice of any actions under this Agreement that are required by Applicable Laws and Regulations.

~~ARTICLE 25.~~ARTICLE 29. MISCELLANEOUS

~~25.1~~29.1 Binding Effect.

This Agreement and the rights and obligations hereof, shall be binding upon and shall inure to the benefit of the successors and permitted assigns of the Parties hereto.

~~25.2~~29.2 Conflicts.

If there is a discrepancy or conflict between or among the terms and conditions of this cover ~~agreement~~Agreement and the Appendices hereto, the terms and conditions of this cover ~~agreement~~Agreement shall be given precedence over the Appendices, ~~except as otherwise expressly agreed to in writing by the Parties.~~; provided, however that Appendix C shall control in the event of a conflict with this cover Agreement. For purposes of this Article 29.2, the term “cover Agreement” shall refer to Articles 1 through 29 of this Agreement.

~~25.3~~29.3 Rules of Interpretation.

This Agreement, unless a clear contrary intention appears, shall be construed and interpreted as follows: (1) the singular number includes the plural number and vice versa; (2) reference to any person includes such person’s successors and assigns but, in the case of a Party,

only if such successors and assigns are permitted by this Agreement, and reference to a person in a particular capacity excludes such person in any other capacity or individually; (3) reference to any agreement (including this Agreement), document, instrument or tariff means such agreement, document, instrument, or tariff as amended or modified and in effect from time to time in accordance with the terms thereof and, if applicable, the terms hereof; (4) reference to any Applicable Laws and Regulations means such Applicable Laws and Regulations as amended, modified, codified, or reenacted, in whole or in part, and in effect from time to time, including, if applicable, rules and regulations promulgated thereunder; (5) unless expressly stated otherwise, reference to any Article, Section or Appendix means such Article of this Agreement or such Appendix to this Agreement, ~~or such Section to the Large Facility Interconnection Procedures or such Appendix to the Large Facility Interconnection Procedures,~~ as the case may be; (6) “hereunder”, “hereof”, “herein”, “hereto” and words of similar import shall be deemed references to this Agreement as a whole and not to any particular Article or other provision hereof or thereof; (7) “including” (and with correlative meaning “include”) means including without limiting the generality of any description preceding such term; and (8) relative to the determination of any period of time, “from” means “from and including”, “to” means “to but excluding” and “through” means “through and including”.

25.429.4 Compliance.

Each Party shall perform its obligations under this Agreement in accordance with Applicable Laws and Regulations, Applicable Reliability Standards, the NYISO OATT and Good Utility Practice. To the extent a Party is required or prevented or limited in taking any action by such regulations and standards, such Party shall not be deemed to be in Breach of this

Agreement for its compliance therewith. When any Party becomes aware of such a situation, it shall notify the other Parties promptly so that the Parties can discuss the amendment to this Agreement that is appropriate under the circumstances.

~~25.5~~29.5 Joint and Several Obligations.

Except as otherwise stated herein, the obligations of ~~NYISO, Developer and Connecting Transmission Owner~~NYSEG and TrAILCo are several, and are neither joint nor joint and several.

~~25.6~~29.6 Entire Agreement.

This Agreement, including all Appendices and Schedules attached hereto, constitutes the entire agreement between the Parties with reference to the subject matter hereof, and supersedes all prior and contemporaneous understandings or agreements, oral or written, between the Parties with respect to the subject matter of this Agreement. There are no other agreements, representations, warranties, or covenants which constitute any part of the consideration for, or any condition to, either Party's compliance with its obligations under this Agreement.

~~25.7~~29.7 No Third Party Beneficiaries.

This Agreement is not intended to and does not create rights, remedies, or benefits of any character whatsoever in favor of any persons, corporations, associations, or entities other than the Parties, and the obligations herein assumed are solely for the use and benefit of the Parties, their successors in interest and permitted their assigns.

~~25.8~~29.8 Waiver.

The failure of a Party to this Agreement to insist, on any occasion, upon strict performance of any provision of this Agreement will not be considered a waiver of any obligation, right, or duty of, or imposed upon, such Party. Any waiver at any time by either Party of its rights with respect to this Agreement shall not be deemed a continuing waiver or a waiver with respect to any other failure to comply with any other obligation, right, duty of this Agreement. ~~Termination or Default of this Agreement for any reason by the Developer shall not constitute a waiver of the Developer's legal rights to obtain Capacity Resource Interconnection Service and Energy Resource Interconnection Service from the NYISO and Connecting Transmission Owner in accordance with the provisions of the NYISO OATT.~~ Any waiver of this Agreement shall, if requested, be provided in writing.

~~25.9~~29.9 Headings.

The descriptive headings of the various Articles of this Agreement have been inserted for convenience of reference only and are of no significance in the interpretation or construction of this Agreement.

~~25.10~~29.10 Multiple Counterparts.

This Agreement may be executed in two or more counterparts, each of which is deemed an original but all constitute one and the same instrument.

~~25.11~~29.11 Amendment.

The Parties may by mutual agreement amend this Agreement, by a written instrument duly executed by all three of the Parties.

~~25.12~~29.12 Modification by the Parties.

The Parties may by mutual agreement amend the Appendices to this Agreement, by a written instrument duly executed by all three of the Parties. Such an amendment shall become effective and a part of this Agreement upon satisfaction of all Applicable Laws and Regulations.

~~25.13~~29.13 Reservation of Rights.

TrAILCo, NYISO and ~~Connecting Transmission Owner~~NYSEG each shall have the right to make unilateral filings with FERC to modify this Agreement with respect to any rates, terms and conditions, charges, classifications of service, rule or regulation under section 205 ~~or any other applicable provision of the Federal Power Act and FERC's rules and regulations thereunder, and Developer shall have the right to make a unilateral filing with FERC to modify this Agreement pursuant to section 206~~ or any other applicable provision of the Federal Power Act and FERC's rules and regulations thereunder; provided that each Party shall have the right to protest any such filing by another Party and to participate fully in any proceeding before FERC in which such modifications may be considered. Nothing in this Agreement shall limit the rights of the Parties or of FERC under sections 205 or 206 of the Federal Power Act and FERC's rules and regulations thereunder, except to the extent that the Parties otherwise mutually agree as provided herein.

~~25.14~~29.14 No Partnership.

This Agreement shall not be interpreted or construed to create an association, joint venture, agency relationship, or partnership among the Parties or to impose any partnership obligation or partnership liability upon any Party. No Party shall have any right, power or

authority to enter into any agreement or undertaking for, or act on behalf of, or to act as or be an agent or representative of, or to otherwise bind, any other Party.

~~25.15~~29.15 **Other Transmission Rights.**

Notwithstanding any other provision of this Agreement, nothing herein shall be construed as relinquishing or foreclosing any rights, including but not limited to firm transmission rights, capacity rights, or transmission congestion rights that ~~the Developer~~either Party shall be entitled to, now or in the future under any other agreement or tariff as a result of, or otherwise associated with, the transmission capacity, if any, created by the System Upgrade Facilities ~~and System Deliverability Upgrades.~~

29.16 Service Agreement.

Upon the date this Agreement becomes effective in accordance with Article 2.1 of this Agreement, the Services Agreement between NYSEG and FirstEnergy Service Company (“FSC”), dated March 18, 2015 (the “Services Agreement”), shall be deemed superseded and NYSEG and FSC shall take all steps necessary to cancel the Services Agreement as a filed rate schedule at FERC. As a condition to the effectiveness of this Agreement, NYSEG and FSC shall execute a letter agreement, which shall be dated as of the Effective Date, confirming that the Services Agreement is superseded upon the effectiveness of this Agreement.

IN WITNESS WHEREOF, the Parties have executed this ~~LGIA~~[Agreement](#) in duplicate originals, each of which shall constitute and be an original effective Agreement between the Parties.

New York State Electric & Gas Corporation

By: _____

Title: _____

Date: _____

NYSEG Control

By: _____

Trans-Allegheny Interstate Line Company

By: _____

Title: _____

Date: _____

New York Independent System Operator, Inc.

By: _____

Title: _____

Date: _____

The signature below of the authorized officer of PJM Interconnection, L.L.C. is for the limited purpose of acknowledging that a representative officer of PJM has read this Agreement as of the 6th day of August, 2015.

PJM Interconnection, L.L.C.

By: _____

_____ (Signature)

Name: _____

_____ (Print)

Title: _____

New York Independent System Operator, Inc. _____

By: _____

Title: _____

Date: _____

[Insert Name of Connecting Transmission Owner]

By: _____

Title: _____

Date: _____

[Insert Name of Developer]

By: _____

Title: _____

Date: _____

APPENDICES

Appendix A

~~Attachment Facilities and System Upgrade Facilities~~

Appendix B

~~Milestones~~

Appendix C

~~Interconnection Details~~

Appendix D

~~Security Arrangements Details~~

Appendix E

~~Commercial Operation Date~~

Appendix F

~~Addresses for Delivery of Notices and Billings~~

Appendix G

~~Interconnection Requirements for a Wind-Generating Plant~~

APPENDIX A

ATTACHMENT FACILITIES AND SYSTEM UPGRADE FACILITIES

1. Attachment Facilities:

None.

~~[insert Developer's Attachment Facilities]:~~

~~(a) — [insert Connecting Transmission Owner's Attachment Facilities]:~~

2. System Upgrade Facilities:

~~[insert(a) Stand Alone System Upgrade Facilities]:~~

A new 345/115 kV substation at the Point of Interconnection ("POI"), named Mainesburg Substation, will be constructed and owned by TrAILCo adjacent to NYSEG's 345 kV transmission line between Homer City and Watercure Road substations (i.e., the Watercure Line) at a point approximately 25.2 line miles south of Watercure Road substation. Mainesburg Substation will include the following major equipment:

- 2 – 345 kV dead-end (pull-off) structures;
- 2 – 115 kV dead-end (pull-off) structures;
- 3 – 345 kV, 3000 A wave traps;
- 3 – 115 kV, 1200 A wave traps;
- 15 – 345 kV arrestors;
- 9 – 115 kV arrestors;
- 6 – line tuners;
- 10 – 362 kV, 3000 A, double side break manually operated disconnect switch;
- 1 – 362 kV, 3000 A, double side break motor operated disconnect switch;
- 7 – 145 kV, 2000A, V-type manually operated disconnect switch;
- 1 – 145 kV, 3000 A, V-type motor operated disconnect switch;
- 4 – 380 kV, 3000 A, 63 kA SF6 breakers;
- 2 – 362 kV, 3000 A, 63 kA SF6 breakers with synchronous switching controller;
- 3 – 145 kV, 3000 A, 40 kA SF6 breakers;
- 1 – 345/115 kV 200/266/333 MVA autotransformer;
- 6 – 345 kV coupling capacitor voltage transformers ("CCVT");
- 6 – 345 kV voltage transformers;
- 9 – 115 kV CCVTs;
- 345 kV bus work;
- 115 kV bus work;
- 345 kV structures;
- 115 kV structures;
- 2 – 95.33 MVAR 362 kV nameplate (86.6 MVAR 345 kV effective) shunt capacitor banks;
- Grounding materials;
- Conduit and cable trench;

- Control cabling;
- Control building with panels for control metering, primary and backup protection, power line carrier systems, and communication;
- 1 – Station battery (125 V DC) with rack;
- 1 – Station battery charger;
- AC Station Service Panels;
- DC panels;
- 1 – 66.395 kV-120/240 V station service transformer;
- Back-up station service transformer;
- Fencing;

(b) System Upgrade Facilities

All work to be performed by Pennsylvania Electric Company (“Penelec”) as described below in this section (b) shall be performed pursuant to an Amended and Restated Engineering and Construction Services Agreement between Penelec and TrAILCo dated August 6, 2015.

(1) Line Loop System Upgrade Facilities from the Everts Drive – Mansfield 115 kV Line

The 115 kV transmission line work at Mainesburg Substation shall include the poles, insulators, and related equipment necessary to route Penelec’s Everts Drive – Mansfield 115 kV line into the Mainesburg Substation. Penelec will complete this work at TrAILCo’s cost and expense. These System Upgrade Facilities shall be owned, operated and maintained by Penelec.

(2) Protection System Upgrade Facilities – Homer City 345 kV Remote End

Due to the segmentation of the Watercure Line with the addition of the Mainesburg Substation, dual-primary relaying will be installed at Homer City Substation. This work will be accomplished by replacing the existing backup relay with a new relay, installing a second pilot channel, and by upgrading the existing power line carrier equipment. Penelec will complete this work at TrAILCo’s cost and expense pursuant to an appropriate agreement between NYSEG and Penelec. These System Upgrade Facilities will be jointly owned, operated and maintained by NYSEG and Penelec.

(3) Protection System Upgrade Facilities – Everts Drive 115 kV Remote End

Due to the segmentation of Penelec’s Everts Drive - Mansfield 115 kV transmission line with the addition of the Mainesburg Substation, relay settings at Everts Drive Substation will need to be adjusted to accommodate the new Mainesburg Substation. Penelec will complete this work at TrAILCo’s cost and expense, and will own these protection System Upgrade Facilities.

(4) Protection SUF – Mansfield 115 kV Remote End

Due to the segmentation of Penelec’s Everts Drive - Mansfield 115 kV transmission line with the addition of the Mainesburg Substation, relay settings at Mansfield Substation will need to be adjusted to accommodate the new Mainesburg Substation. Penelec will complete this work at TrAILCo’s cost and expense, and will own these protection SUF.

(5) 345 kV Line Loop

TrAILCo, on behalf of NYSEG, will engineer, design, procure all materials, and construct the Homer City – Watercure Road 345 kV line modifications at the Mainesburg Substation POI. TrAILCo will perform this System Upgrade Facilities work, at TrAILCo’s cost and expense, through its affiliate, Penelec, who will act as TrAILCo’s subcontractor pursuant to Article 26. This would include obtaining any rights or way agreements, permits, and/or certifications required to modify the line. This would also include all equipment for the 345 kV line taps (line structures, conductor, insulators, and terminations on dead-end structures, etc.). All work will be performed using NYSEG standards. The new line loop will be owned and operated by NYSEG. TrAILCo will pay for the cost of NYSEG to review and accept the engineering, design, procurement of materials, provide standards, and attend meetings and site visits as needed. The loop is necessary to support TrAILCo’s construction of the Mainesburg Substation. The scope of work for the line loop is as follows:

- Install two wood H-frames (#B-343-2 and #B-344-2) outside of Mainesburg substation.
- Install 8 steel poles (two 3-pole structures #B-343 and #B-344 and two monopoles #B-343-1 and #B-344-1). Install all anchors guys and span guys.
- Transfer existing conductors and shield wires from existing B-343 H-frame to the south side of new B-343 3-pole structure. Transfer existing conductor and shield wires from existing B-343 H-frame to the north side of new B-344 3-pole structure. Resag and clip wires.
- Remove excess wire from the north side of B-343 and the south side of B-344.
- Remove two existing H-frames (B-343 and B-344).
- Install new conductors (2156 ACSR) and shield wires (7/16” EHS steel) from 3-pole structures to each monopole, through the new wood H-frames, and into Mainesburg substation.

(6) Watercure Road Relay Upgrades

The following System Upgrade Facilities shall be completed by NYSEG at TrAILCo’s cost and expense, and will be owned by NYSEG.

Phase 1

- Remove 100W PLC amplifiers on 30 line
- Attend Siemens 7SA training (3 days)
- Review Proposed Mainesburg settings
- Issue new Watercure Road 30 Line Terminal Settings

- Update Aspen and Relay databases
- Update Watercure Road operating instructions
- Install new settings
- Perform PLC level checks
- Perform End to End Tests

Phase 2

The Phase 2 protection scheme will establish a second pilot channel between Mainesburg and Watercure Road substations. All costs associated with the Phase 2 protection scheme will be the responsibility of TrAILCo. TrAILCo will be responsible for the engineering, design, and procurement of phase 2 project and construction in the TrAILCo facilities. NYSEG will be responsible for the engineering, design review and the construction in NYSEG facilities. NYSEG and TrAILCo will work together to determine the most viable communications requirements. The preliminary scope of work for the Phase 2 protection scheme is as follows:

- Install a SEL-2506 fiber optic transceiver at Watercure Road adjacent to existing Siemens 7SA relay (to convert the 7SA I/O contacts to a MB signal over fiber).
- Watercure Road MB signal to be routed via 2815 transceiver to a new JUMX at Watercure Road then, via a new 6 mile ADSS SM fiber run, to 14th Street substation.
- At 14th Street substation, install a new JUMX to connect to the new T1 circuit from Mainesburg substation (ordered by FE) via a Positron shelf (Positron needs to be confirmed).

The above scope of work for Phase 2 is subject to modification based on a number of factors, including further engineering review.

3. Cost Estimates:

a. ~~Insert Other~~ System Upgrade Facilities:

(1) Mainesburg Substation

The estimated cost for engineering, procuring materials, and constructing Mainesburg Substation is \$22,283,600.

(2) Line Loop System Upgrade Facilities from the Everts Drive – Mansfield 115 kV Line

The estimated cost for engineering, procuring materials, and constructing the 115 kV line loop is \$541,400.

~~System Deliverability Upgrades:~~

(3) Protection System Upgrade Facilities – Homer City 345 kV Remote End

The estimated cost for engineering, procuring materials, and constructing the relay upgrades at Homer City substation is \$333,200.

(4) Protection System Upgrade Facilities – Everts Drive 115 kV Remote End

The estimated cost for engineering and implementing the relay setting changes at Everts Drive Substation is \$46,100.

(5) Protection System Upgrade Facilities – Mansfield 115 kV Remote End

The estimated cost for engineering and implementing the relay setting changes at Mansfield Substation is \$81,300.

(6) 345 kV Line Loop

The estimated cost for TrAILCo, on behalf of NYSEG, to engineer, procure materials, and construct the 345 kV line loop is \$3,055,000. The estimated cost for NYSEG work associated with the 345 kV transmission line loop work is \$50,000.

(7) Watercure Road Relay Upgrades

The estimate cost for engineering, procuring materials, and constructing the Phase 1 relay upgrades at Watercure Road substation is \$101,200. The estimate cost for engineering, procuring materials, and constructing the Phase 2 relay upgrades at Watercure Road substation is \$750,000.

5. Design Standard

The System Upgrade Facilities and related facilities to be constructed by TrAILCo (or by Penelec on behalf of TrAILCo), with the exception of the 345 kV Line Loop work, will be designed to meet the following requirements:

- FirstEnergy Transmission Planning Criteria
- FirstEnergy Requirements for Transmission Connected Facilities
- FirstEnergy Transmission System Protection Practices
- FirstEnergy Substation Design Standards Manual
- Power Circuit Breakers 23 kV through 500 kV (“FE-BKR-1”)
- Open Rack Power Capacitors (“FE-CAP-1”)
- Liquid Immersed Substation Power & GSU Transformers (“FE-TR-1”)

(Added)

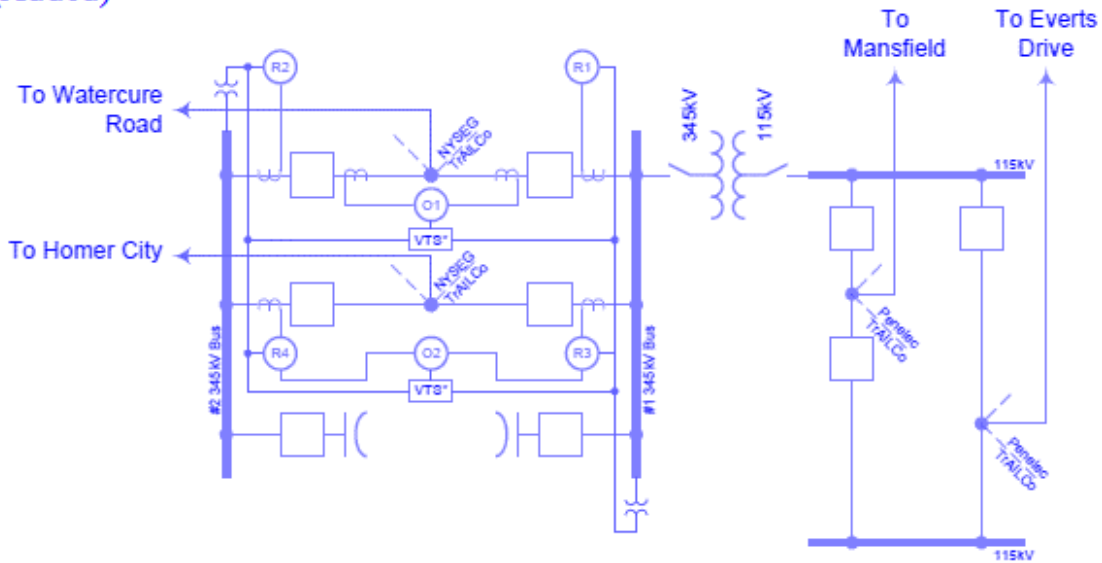

All indicated meters shall be revenue quality meters.

*Voltage Transfer Scheme (VTS): Primary potential for meter O1 is from the #1 345kV bus; backup potential is from the #2 345kV bus. Primary potential for meter O2 is from the #2 345kV bus; backup potential is from the #1 345kV bus.

- The point of change of ownership and point of interconnection is where the NYSEG owned transmission line attaches to the TrAILCo owned Mainesburg substation dead-end structure.

FE	—————
FE (Metering, Current)	—————
FE (Metering, Voltage)	—————
NYSEG	—————
Point of Interconnection	●

APPENDIX B

MILESTONES

In accordance with Article 5.1 of this Agreement, the following milestone dates shall apply to the designated performance:

1. Outage Start Date – the date that the Watercure Line outage commences which shall be no less than fourteen (14) days from the date TrAILCo’s receives NYSEG’s construction authorization pursuant to Section 5.3.3 of this Agreement.
2. Initial Energization Date – that date which is thirty (30) days from the Outage Start Date.
3. Trial Period – shall be defined as the ten (10) day period from the Initial Energization Date needed for commissioning and testing.
4. Commercial Operation Date – shall be defined as that date which is ten (10) days after the Initial Energization Date

Additionally, the following milestone completion dates shall apply to the designated Stand Alone System Upgrade Facilities described in Appendix A:

- | | |
|---|----------------------------------|
| <u>i. Mainesburg Substation (Appendix A, § 2(a)):</u> | <u>Commercial Operation Date</u> |
| <u>ii. Line Loop SUF Everts Drive (Appendix A, § 2(b)(1)):</u> | <u>In Service/Complete</u> |
| <u>iii. Protection SUF – Homer City (Appendix A, § 2(b)(2)):</u> | <u>Commercial Operation Date</u> |
| <u>iv. Protection SUF – Everts Drive (Appendix A, § 2(b)(3)):</u> | <u>In Service/Complete</u> |
| <u>v. Protection SUF – Mansfield (Appendix A, § 2(b)(4)):</u> | <u>In Service/Complete</u> |
| <u>vi. 345 kV Line Loop (Appendix A, § 2(b)(5)):</u> | <u>Commercial Operation Date</u> |
| <u>vii. Watercure Road Relay Upgrades (Appendix A, § 2(b)(6)):</u> | |
| <u>Phase 1: the Commercial Operation Date provided that NYSEG completes the work at the Watercure Road substation in a timely manner.</u> | |
| <u>Phase 2: that date which is no later than three hundred and sixty-five (365) days after the Commercial Operation Date.</u> | |

The duration of the Work Period defined in Appendix C, Section C(2), accounts for the period from the Outage Start Date to the Commercial Operation Date of the Transmission Facility (i.e., Mainesburg Substation).

APPENDIX C – INTERCONNECTION AND CONSTRUCTION PROVISIONS

A. Interconnection Description

The Mainesburg 345/115 kV project is a new 345 to 115 kV substation in the northeast region of the Penelec service territory. The Project is a mandatory PJM Interconnection, L.L.C. (“PJM”) baseline Regional Transmission Expansion Plan (“RTEP”) upgrade that was presented at the September 7, 2011 PJM Transmission Expansion Advisory Committee (“TEAC”) meeting and was assigned baseline RTEP upgrade ID b1608. Baseline upgrade ID b1608 includes the construction of Mainesburg 345/115 kV substation connecting to the Homer City – Watercure Road 345 kV and Everts Drive – Mansfield 115 kV line. PJM also identified the need to install two (2) 345 kV capacitors at Mainesburg substation at the November 3, 2011 TEAC meeting and assigned baseline RTEP upgrade ID b1802. The Project loops the Homer City – Watercure Road 345 kV line and the Everts Drive – Mansfield portion of the East Towanda – Farmers Valley 115 kV line into Mainesburg substation which consists of a 345/115 kV transformer and ring bus on the 115 kV and 345 kV. The project will connect to the NYISO system on the NYSEG Homer City – Watercure Road 345 kV line approximately 151.8 miles from Homer City substation and approximately 25.2 miles from NYSEG’s Watercure Road substation. The point of change of ownership and point of interconnection (as set forth in Figure 1 of Appendix A) is where the NYSEG owned transmission line attaches to the TrAILCo owned Mainesburg substation dead-end structure. The project will connect to the Penelec system on the Penelec Everts Drive – Mansfield 115 kV line approximately 8.5 miles from Everts Drive substation and 5.6 miles from Mansfield substation.

B. Interconnection Provisions

The following are additional interconnection provisions to which the Parties agree to be bound:

1. By June 1, 2016, TrAILCo shall install, at TrAILCo’s cost and expense, the following NYISO-approved metering transformers: revenue quality PTs (.3% accuracy) to replace the current CCVTs. Said NYISO-approved metering transformers shall be owned by TrAILCo;
2. TrAILCo, at its cost and expense, shall install a GE D20MX RTU (“FE RTU”) at the Mainesburg Substation. TrAILCo shall utilize the FE RTU to send metering data (volts, amps, watts, vars and revenue MWh) and breaker status directly to the NYSEG Energy Control Center. The data provided to NYSEG via the FE RTU will be in a DNP3 protocol stream, through a 4wire audio tone, Bell 202T leased line equivalent connection to JMUX equipment. The communication median will be a leased T1 phone circuit from Mainesburg Substation to the NYSEG Energy Control Center. The RTU shall be owned and operated by TrAILCo at its cost and expense;

It is anticipated that the leased T1 phone circuit may not be available at the Commercial Operation Date. Therefore, at the time of the Commercial Operation Date, the data provided to NYSEG via the FE RTU, as described in the paragraph above, will be through a temporary solution consisting of a combination of cellular modem and 4 Wire/Telco technologies, the specifics of which are to be agreed upon by NYSEG and TrAILCo;

3. Prior to Commercial Operation Date of the Mainesburg Substation, TrAILCo shall, at its own cost and expense, establish dial-up access to all 345 kV revenue metering at Mainesburg Substation for data collection via NYSEG's MV-90 data collection system;
4. NYISO shall, at TrAILCo's cost and expense, provide to TrAILCo a RFL 9800 series shelf, 98 TMX cards and telemetry circuits ("NYISO Telemetry Equipment"). The NYISO Telemetry Equipment shall be installed by TrAILCo in existing racks at the Mainesburg Substation. TrAILCo shall utilize the NYISO Telemetry Equipment to provide the NYISO data in accordance with NYISO requirements. The NYISO Telemetry Equipment will receive values from meters at the Mainesburg Substation and create an analog signal. The NYISO Telemetry Equipment shall be operated and maintained at TrAILCo's cost and expense.

C. Construction Provisions

The following are additional construction provisions to which the Parties agree to be bound:

1. TrAILCo and NYSEG each have obligations under this Agreement to construct and/or install System Upgrade Facilities. The Scope of Work for TrAILCo's construction and installation of System Upgrade Facilities is set forth in sections 2(a), 2(b)(1), 2(b)(2), 2(b)(3), 2(b)(4) and Phase 2 of 2(b)(6) of Appendix A. The Scope of Work for NYSEG's construction and installation of System Upgrade Facilities is set forth in section 2(b)(5) and Phase 1 of section 2(b)(6) of Appendix A. NYSEG has delegated to TrAILCo the obligation to undertake and complete, at TrAILCo's cost and expense, the NYSEG Scope of Work described in section 2(b)(5) of Appendix A. For clarity, the Scope of Work described in Phase 1 of section 2(b)(6) of Appendix A shall be performed at TrAILCo's cost and expense.
2. TrAILCo shall use best efforts to complete the scope of work described in section 2(b)(5) of Appendix A (the "TrAILCo Scope of Work") during the period (the "Work Period") between the commencement of the scheduled outage of Watercure Line and the Commercial Operation Date of the Transmission Facility, which Work Period shall be forty (40) days in duration. TrAILCo acknowledges that TIME IS OF THE ESSENCE to complete the TrAILCo Scope of Work during the Work Period. It is acknowledged that TrAILCo's inability to complete all of the work set forth in the TrAILCo Scope of Work within the Work Period

may cause NYSEG to incur economic damages and losses. If the work required by the TrAILCo Scope of Work is not completed by the expiration of the Work Period and NYSEG has suffered economic damages or losses as a result, then NYSEG shall provide a written notice and an invoice to TrAILCo that provides reasonable detail as to the cause and extent of the damages and or losses and the amount due from TrAILCo to NYSEG. Subject to TrAILCo's rights under this Section 2, TrAILCo shall pay the amount due within five (5) days of the date of the invoice. TrAILCo's obligation to pay the amount invoiced pursuant to this provision shall be absolute and unconditional and without counterclaim or set-off except in the event the TrAILCo Scope of Work is not complete by the expiration of the Work Period because of an act or omission of NYSEG, an act or omission of a third-party not under contract with or control of TrAILCo or any affiliate of TrAILCo for purposes of the TrAILCo Scope of Work, an act or omission of the PJM Interconnection, L.L.C. ("PJM") and/or the New York Independent System Operator, Inc. ("NYISO"), or an event beyond the reasonable control of TrAILCo (e.g., force majeure).

3. NYSEG, at TrAILCo's expense, shall provide commercially reasonable cooperation and communication to TrAILCo and shall provide all reasonably requested documents, information, consents, and access to facilities and property to permit TrAILCo to undertake and complete the TrAILCo Scope of Work during the Work Period.
4. NYSEG's agreement to permit TrAILCo to undertake the TrAILCo Scope of Work is conditioned upon TrAILCo delivering to NYSEG, before the initiation of the Work Period, of a surety bond (the "Surety Bond") in the amount of FIVE MILLION DOLLARS (\$5,000,000) in favor of NYSEG issued by a provider reasonably acceptable to TrAILCo and NYSEG (the "SB Provider") and in form and substance reasonably acceptable to NYSEG, pursuant to which SB Provider guarantees the performance and financial obligations of TrAILCo pursuant to Sections 2(b)(5) and 2(b)(6) of Appendix A and the performance and financial obligations of TrAILCo pursuant to sections C(2), C(10) and C(11) of this Appendix C.
5. The Parties acknowledge and understand that the compliance dates and time periods set forth in Sections B(1), B(2) and B(3) of this Appendix C are subject to modifications due to: (a) outage scheduling procedures and restrictions; (b) acts or directives of PJM and/or NYISO; and (c) the finalization of applicable design and engineering specifications for equipment and facilities to be provided or installed pursuant to this Agreement.
6. TrAILCo shall undertake the TrAILCo Scope of Work at its cost and expense, and consistent with this Agreement and Good Utility Practice. The ownership of equipment and facilities installed by TrAILCo in connection with the Scope of Work shall be set forth in this Agreement.

7. NYSEG may monitor and inspect TrAILCo's performance of the TrAILCo Scope of Work. TrAILCo shall maintain adequate communication and coordination between TrAILCo and NYSEG during the Work Period, and TrAILCo shall notify NYSEG of the commencement of the TrAILCo Scope of Work and the completion of the TrAILCo Scope of Work. For purposes of the performance of the TrAILCo Scope of Work, each Party hereby designates the following point of contact for purposes of communication during the Work Period:

For TrAILCo: Michael W. Hughes
c/o FirstEnergy Service Company
2800 Pottsville Pike
Reading, PA 19612
Office: 610-921-6587
Cell: 484-269-4903
Email: mhughes@firstenergycorp.com

For NYSEG: Raymond P. Kinney
Director – Transmission, Energy
Services
New York State Electric & Gas
Corporation
18 Link Drive
P.O. Box 5224
Binghamton, NY 13902-5224
Office: 607-762-4321
Cell: 607-725-7166
Email: rpkkinney@nyseg.com

8. The energization of the Mainesburg Substation shall occur in accordance with the testing and commissioning plan to be provided by TrAILCo to NYSEG, which testing and commissioning plan shall be subject to NYSEG's reasonable satisfaction. The Commercial Operation Date of the Mainesburg Substation shall occur only after this Agreement is deemed effective by FERC. TrAILCo shall procure and maintain insurance coverage, for itself and its subcontractors, in accordance with the requirements set forth in Article 18 of this Agreement hereto, and incorporated herein by this reference.

9. Any Party shall report to the other Party verbally and in writing as soon as practical all accidents or occurrences resulting in injuries to any person, including death, and any property damage arising out of this Agreement.

10. TrAILCo will indemnify, defend at its expense and hold harmless NYSEG and its Affiliates, and each of their directors, officers, employees, and agents (the "Indemnitee") from and against any and all liabilities, claims, demands, suits, losses, costs, fees, damages or expenses (together, "Losses") it may suffer, or for

which it may be held liable including, without limitation, reasonable expenses and attorneys fees incurred in the connection therewith, by reason of: (a) any work-related accident or injury affecting an employee, agent or subcontractor of TrAILCo, arising in connection with work performed under the TrAILCo Scope of Work; (b) any claim by an agency or instrumentality of the federal, state or any local government, or by an employee, agent or subcontractor of TrAILCo alleging that the Indemnatee is liable to any party, for any reason, due to TrAILCo's negligent performance of the work required by the TrAILCo Scope of Work or omissions by an employee, agent or subcontractor of TrAILCo; (c) bodily injury, including death, to any person or persons due to the actions or omissions of TrAILCo or its agents or subcontractors; (d) damage to or destruction of any property, including loss of use thereof, due to the actions or omissions of TrAILCo, or its agents or subcontractors; provided, however, TrAILCo shall not be required to indemnify, hold harmless and defend the Indemnatee to the extent Losses related to matters described in sections (a), (b), (c) and (d) above arise from the Indemnatee's negligence or willful misconduct. Individual employees, agents and subcontractors of TrAILCo who are performing work pursuant to the TrAILCo Scope of Work shall be considered to be employees, agents or subcontractors of TrAILCo for all purposes under this Agreement, notwithstanding any judicial or administrative determination that such employees, agents or subcontractors of the other party should be regarded as employees under applicable law. All actions of the employees, agents and subcontractors of TrAILCo under this Agreement shall be deemed to be actions of TrAILCo under this Agreement. This provision shall continue and survive any expiration or termination of this Agreement and completion of the TrAILCo Scope of Work.

11. Return of NYSEG Facilities to Status Quo Ante. It is the express intention of the Parties that in the absence of the Mainesburg Substation, the Watercure Line and appurtenant facilities should be restored to their prior electrical configuration. Therefore, if the Mainesburg Substation is not in commercial operation by the expiration of the Work Period, or if after the attempted commercial operation of the Mainesburg Substation it becomes evident in the reasonable determination of NYSEG, upon consultation with the NYISO, TrAILCo and PJM, that the Mainesburg Substation will not be successfully placed in commercial operation, then TrAILCo shall take the steps necessary to return, as soon as practicable, all NYSEG facilities to the electrical configuration and status of such facilities prior to the commencement of the TrAILCo Scope of Work by TrAILCo pursuant to this Agreement; provided, however, that if the Mainesburg Substation can be commissioned and placed in commercial operation within a reasonably short period of time following the expiration of the Work Period, then the Parties shall work together to accomplish such commercial operation and TrAILCo shall have no restoration obligations, but TrAILCo shall continue to have the payment obligations pursuant to Section C(2) above, subject to the provisions of Section C(2) above. Such work to restore the NYSEG facilities shall be done at the cost

and expense of TrAILCo and with NYSEG's cooperation and coordination (and with the coordination with PJM and NYISO), and shall be completed as soon as is practicable.

~~INTERCONNECTION DETAILS~~

APPENDIX D

SECURITY ARRANGEMENTS DETAILS

Infrastructure security of New York State [Transmission System and PJM](#) Transmission System equipment and operations and control hardware and software is essential to ensure ~~day-~~
~~to-day~~[day-to-day](#) New York State [Transmission System and PJM](#) Transmission System reliability and operational security. The Commission will expect [PJM](#), the NYISO, all Transmission Owners, ~~all Developers~~ [\(including NYSEG and TrAILCo\)](#), and all other Market Participants to comply with the recommendations offered by the President's Critical Infrastructure Protection Board and, eventually, best practice recommendations from the electric reliability authority. All public utilities will be expected to meet basic standards for system infrastructure and operational security, including physical, operational, and ~~cyber-~~
~~security~~[cyber-security](#) practices.

~~APPENDIX E~~

~~COMMERCIAL OPERATION DATE~~

~~{Date}~~

~~{NYISO Address} _____~~

~~{Connecting Transmission Owner Address}~~

~~Re: _____ Large Generating Facility~~

~~Dear _____:~~

~~On {Date} {Developer} has completed Trial Operation of Unit No. _____. This letter confirms that {Developer} commenced Commercial Operation of Unit No. ____ at the Large Generating Facility, effective as of {Date plus one day}.~~

~~Thank you.~~

~~{Signature}~~

~~{Developer Representative}~~

APPENDIX F

E – ADDRESSES FOR DELIVERY OF NOTICES AND BILLINGS

Notices:

TrAILCo:

FirstEnergy Service Company
Attn: Manager: FERC & Wholesale Connection Support
76 South Main St.
Akron, OH 44308
Email: mthorn@firstenergycorp.com

NYSEG:

New York State Electric & Gas Corporation
Attn: Transmission Services – Manager Programs/Projects
PO Box 5224
Binghamton, New York 13902-5224
Phone: (607) 762-8073
Fax: (607) 762-8666

NYISO:

~~[To be supplied.]~~

~~[To be supplied.]~~ Connecting Before commercial operation of the Transmission Owner Facility:

New York Independent System Operator, Inc.
Attn: Vice President, System and Resource Planning
10 Krey Boulevard
Rensselaer, NY 12144
Phone: (518) 356-6000
Fax: (518) 356-6118

Developer:

After commercial operation of the Transmission Facility:

New York Independent System Operator, Inc.
Attn: Vice President, Operations
10 Krey Boulevard
Rensselaer, NY 12144
Phone: (518) 356-6000
Fax: (518) 356-6118

~~{To be supplied.}~~

Billings and Payments:

~~Connecting Transmission Owner:~~

~~{To be supplied.}~~

~~Developer~~TrAILCo:

~~{To be supplied.}~~

FirstEnergy Service Company
Attn: Manager: FERC & Wholesale Connection Support
76 South Main St.
Akron, OH 44308
Email: mthorn@firstenergycorp.com

NYSEG:

New York State Electric & Gas Corporation
Attn: Energy Services – Manager, Billing & Risk Management
PO Box 5224
Binghamton, New York 13902-5224

~~Alternative Forms of Delivery of Notices (telephone, facsimile or email)~~ ALTERNATIVE FORMS OF DELIVERY OF NOTICES (TELEPHONE, FACSIMILE OR EMAIL):

TrAILCo:

FirstEnergy Service Company
Attn: Manager: FERC & Wholesale Connection Support
76 South Main St.
Akron, OH 44308
Email: mthorn@firstenergycorp.com
Phone: (330) 384-3889

FirstEnergy Service Company
Attn: Attorney for FERC & Wholesale Connection Support
FERC & Wholesale Connection Support
76 South Main St.
Akron, OH 44308
Email: pnrao@firstenergycorp.com
Phone: (330) 384-2422

NYSEG:

New York State Electric & Gas Corporation
Attn: Transmission Services – Manager Programs/Projects
PO Box 5224
Binghamton, New York 13902-5224
Phone: (607) 762-8073
Fax: (607) 762-8666

NYISO:

~~[To be supplied.]~~

~~[To be supplied.]~~ Connecting Before commercial operation of the Transmission Owner Facility:

Developer:

New York Independent System Operator, Inc.
Attn: Vice President, System and Resource Planning
10 Krey Boulevard

Rensselaer, NY 12144
Phone: (518) 356-6000
Fax: (518) 356-6118

~~{To be supplied.}~~

APPENDIX G

INTERCONNECTION REQUIREMENTS FOR A WIND GENERATING PLANT

Appendix G sets forth requirements and provisions specific to a wind generating plant. All other requirements of this LGIA continue to apply to wind generating plant interconnections.

A. Technical Standards Applicable to a Wind Generating Plant

i. Low Voltage Ride-Through (LVRT) Capability

A wind generating plant shall be able to remain online during voltage disturbances up to the time periods and associated voltage levels set forth in the standard below. The LVRT standard provides for a transition period standard and a post-transition period standard.

Transition Period LVRT Standard

The transition period standard applies to wind generating plants subject to FERC Order 661 that have either: (i) interconnection agreements signed and filed with the Commission, filed with the Commission in unexecuted form, finally executed as conforming agreements, or filed with the Commission as non-conforming agreements between January 1, 2006 and December 31, 2006, with a scheduled in-service date no later than December 31, 2007, or (ii) wind generating turbines subject to a wind turbine procurement contract executed prior to December 31, 2005, for delivery through 2007.

1. Wind generating plants are required to remain in-service during three-phase faults with normal clearing (which is a time period of approximately 4–9 cycles) and single line-to-ground faults with delayed clearing, and subsequent post-fault voltage recovery to pre-fault voltage unless clearing the fault effectively disconnects the generator from the system. The clearing time requirement for a three-phase fault will be specific to the wind generating plant substation location, as determined by and documented by the Connecting Transmission Owner for the Transmission District to which the wind generating plant will be interconnected. The maximum clearing time the wind generating plant shall be required to withstand for a three-phase fault shall be 9 cycles at a voltage as low as 0.15 p.u., as measured at the high side of the wind generating plant step-up transformer (i.e., the transformer that steps the voltage up to the transmission interconnection voltage or “GSU”), after which, if the fault remains following the location-specific normal clearing time for three-phase faults, the wind generating plant may disconnect from the transmission system.
2. This requirement does not apply to faults that would occur between the wind generator terminals and the high side of the GSU or to faults that would result in a voltage lower than 0.15 per unit on the high side of the GSU serving the facility.
3. Wind generating plants may be tripped after the fault period if this action is intended as part of a special protection system.
4. Wind generating plants may meet the LVRT requirements of this standard by the performance of the generators or by installing additional equipment (e.g., Static VAR Compensator, etc.) within the wind generating plant or by a combination of generator performance and additional equipment.
5. Existing individual generator units that are, or have been, interconnected to the network at the same location at the effective date of the Appendix G LVRT Standard are exempt

from meeting the Appendix G LVRT Standard for the remaining life of the existing generation equipment. Existing individual generator units that are replaced are required to meet the Appendix G LVRT Standard.

Post-transition Period LVRT Standard

All wind generating plants subject to FERC Order No. 661 and not covered by the transition period described above must meet the following requirements:

1. ~~Wind generating plants are required to remain in service during three-phase faults with normal clearing (which is a time period of approximately 4–9 cycles) and single line-to-ground faults with delayed clearing, and subsequent post-fault voltage recovery to pre-fault voltage unless clearing the fault effectively disconnects the generator from the system. The clearing time requirement for a three-phase fault will be specific to the wind generating plant substation location, as determined by and documented by the Connecting Transmission Owner for the Transmission District to which the wind generating plant will be interconnected. The maximum clearing time the wind generating plant shall be required to withstand for a three-phase fault shall be 9 cycles after which, if the fault remains following the location-specific normal clearing time for three-phase faults, the wind generating plant may disconnect from the transmission system. A wind generating plant shall remain interconnected during such a fault on the transmission system for a voltage level as low as zero volts, as measured at the high-voltage side of the wind GSU.~~
2. ~~This requirement does not apply to faults that would occur between the wind generator terminals and the high side of the GSU.~~
3. ~~Wind generating plants may be tripped after the fault period if this action is intended as part of a special protection system.~~
4. ~~Wind generating plants may meet the LVRT requirements of this standard by the performance of the generators or by installing additional equipment (e.g., Static VAR~~

~~Compensator) within the wind generating plant or by a combination of generator performance and additional equipment.~~

- ~~5. Existing individual generator units that are, or have been, interconnected to the network at the same location at the effective date of the Appendix G LVRT Standard are exempt from meeting the Appendix G LVRT Standard for the remaining life of the existing generation equipment. Existing individual generator units that are replaced are required to meet the Appendix G LVRT Standard.~~

~~After commercial operation of the Transmission Facility:~~

~~New York Independent System Operator, Inc.~~

~~Attn: Vice President, Operations~~

~~10 Krey Boulevard~~

~~Rensselaer, NY 12144~~

~~Phone: (518) 356-6000~~

~~Fax: (518) 356-6118~~

~~**ii. Power Factor Design Criteria (Reactive Power)**~~

~~A wind generating plant shall maintain a power factor within the range of 0.95 leading to 0.95 lagging, measured at the Point of Interconnection as defined in this LGIA, if the ISO's System Reliability Impact Study shows that such a requirement is necessary to ensure safety or reliability.~~

~~The power factor range standard can be met using, for example without limitation, power electronics designed to supply this level of reactive capability (taking into account any limitations due to voltage level, real power output, etc.) or fixed and switched capacitors if agreed to by the Connecting Transmission Owner for the Transmission District to which the wind generating plant will be interconnected, or a combination of the two. The Developer shall not disable power factor equipment while the wind plant is in operation. Wind plants shall also be able to provide sufficient dynamic voltage support in lieu of the power system stabilizer and automatic voltage regulation at the generator excitation system if the System Reliability Impact Study shows this to be required for system safety or reliability.~~

~~**iii. Supervisory Control and Data Acquisition (SCADA) Capability**~~

~~The wind plant shall provide SCADA capability to transmit data and receive instructions from the ISO and/or the Connecting Transmission Owner for the Transmission District to which the wind generating plant will be interconnected, as applicable, to protect system reliability. The Connecting Transmission Owner for the Transmission District to which the wind generating plant will be interconnected and the wind plant Developer shall determine what SCADA information is essential for the proposed wind plant, taking into account the size of the plant and~~

~~its characteristics, location, and importance in maintaining generation resource adequacy and transmission system reliability in its area.~~

Summary report:	
Litéra® Change-Pro TDC 7.5.0.127 Document comparison done on 08/07/2015 10:08:47 AM	
Style name: H&W Standard	
Intelligent Table Comparison: Active	
Original DMS: iw://EMF_US/HW_US/45891393/7	
Modified DMS: iw://EMF_US/HW_US/56335095/8	
Changes:	
<u>Add</u>	1340
Delete	1381
Move From	0
<u>Move To</u>	0
<u>Table Insert</u>	2
Table Delete	0
Table moves to	0
Table moves from	0
Embedded Graphics (Visio, ChemDraw, Images etc.)	1
Embedded Excel	0
Format changes	0
Total Changes:	2724