

**~~Appendix 9~~--STANDARD SMALL GENERATOR
INTERCONNECTION AGREEMENT (SGIA)←**

AMONG THE

NIAGARA MOHAWK POWER CORPORATION d/b/a NATIONAL GRID

AND

NIAGARA WIND POWER, LLC

AND

ERIE WIND, LLC

dated as of _____, 2010

(for the Steel Winds I Facility)

(Applicable To Generating Facilities No Larger Than 20 MW)

TABLE OF CONTENTS

	<u>Page No.</u>
<u>Article 1.</u> <u>Scope and Limitations of Agreement</u>	3
<u>1.1</u> <u>Applicability</u>	3
<u>1.2</u> <u>Purpose</u>	3
<u>1.3</u> <u>Scope of Interconnection Service</u>	3
<u>1.4</u> <u>Limitations</u>	3
<u>1.5</u> <u>Responsibilities of the Parties</u>	3
<u>1.6</u> <u>Parallel Operation Obligations</u>	5
<u>1.7</u> <u>Metering</u>	5
<u>1.8</u> <u>Reactive Power</u>	5
<u>1.9</u> <u>Interim Constrained Operation Period</u>	6
<u>1.10</u> <u>Capitalized Terms</u>	6
<u>Article 2.</u> <u>Inspection, Testing, Authorization, and Right of Access</u>	6
<u>2.1</u> <u>Equipment Testing and Inspection</u>	6
<u>2.2</u> <u>Authorization Required Prior to Parallel Operation</u>	7
<u>2.3</u> <u>Right of Access</u>	7
<u>Article 3.</u> <u>Effective Date, Term, Termination, and Disconnection</u>	7
<u>3.1</u> <u>Effective Date</u>	7
<u>3.2</u> <u>Terms of Agreement</u>	8
<u>3.3</u> <u>Termination</u>	8
<u>3.4</u> <u>Temporary Disconnection</u>	9
<u>Article 4.</u> <u>Cost Responsibility for Interconnection Facilities and</u> <u>Distribution Upgrades</u>	11
<u>4.1</u> <u>Interconnection Facilities</u>	11
<u>4.2</u> <u>Distribution Upgrades</u>	11
<u>Article 5.</u> <u>Cost Responsibility for System Upgrade Facilities and System Deliverability</u> <u>Upgrades</u>	12
<u>5.1</u> <u>Applicability</u>	12
<u>5.2</u> <u>System Upgrades</u>	12
<u>5.3</u> <u>Special Provisions for Affected Systems</u>	12
<u>Article 6.</u> <u>Billing, Payment, Milestone, and Financial Security</u>	12
<u>6.1</u> <u>Billing and Payment Procedures and Financial Accounting</u>	12
<u>6.2</u> <u>Milestones</u>	13
<u>6.3</u> <u>Financial Security Arrangements</u>	14

<u>Article 7</u>	<u>Assignment, Liability, Indemnity, Force Majeure, Consequential Damages, and Default</u>	<u>14</u>
<u>7.1</u>	<u>Assignment</u>	<u>14</u>
<u>7.2</u>	<u>Limitation of Liability</u>	<u>15</u>
<u>7.3</u>	<u>Indemnity</u>	<u>15</u>
<u>7.4</u>	<u>Consequential Damages</u>	<u>16</u>
<u>7.5</u>	<u>Force Majeure</u>	<u>16</u>
<u>7.6</u>	<u>Breach and Default</u>	<u>17</u>
<u>7.7</u>	<u>Liability of Interconnection Customer and Erie Wind</u>	<u>17</u>
<u>Article 8</u>	<u>Insurance</u>	<u>17</u>
<u>Article 9.</u>	<u>Confidentiality</u>	<u>18</u>
<u>Article 10.</u>	<u>Disputes</u>	<u>19</u>
<u>Article 11.</u>	<u>Taxes</u>	<u>20</u>
<u>Article 12.</u>	<u>Miscellaneous</u>	<u>20</u>
<u>12.1</u>	<u>Governing Law, Regulatory Authority, and Rules</u>	<u>20</u>
<u>12.2</u>	<u>Amendment</u>	<u>20</u>
<u>12.3</u>	<u>No Third-Party Beneficiaries</u>	<u>20</u>
<u>12.4</u>	<u>Waiver</u>	<u>21</u>
<u>12.5</u>	<u>Entire Agreement</u>	<u>21</u>
<u>12.6</u>	<u>Multiple Counterparts</u>	<u>21</u>
<u>12.7</u>	<u>No Partnership</u>	<u>21</u>
<u>12.8</u>	<u>Severability</u>	<u>21</u>
<u>12.9</u>	<u>Security Arrangements</u>	<u>22</u>
<u>12.10</u>	<u>Environmental Releases</u>	<u>22</u>
<u>12.11</u>	<u>Subcontractors</u>	<u>22</u>
<u>12.12</u>	<u>Reservation of Rights</u>	<u>23</u>
<u>Article 13.</u>	<u>Notices</u>	<u>23</u>
<u>13.1</u>	<u>General</u>	<u>23</u>
<u>13.2</u>	<u>Billing and Payment</u>	<u>24</u>
<u>13.3</u>	<u>Alternative Forms of Notice</u>	<u>24</u>
<u>13.4</u>	<u>Designated Operating Representative</u>	<u>25</u>
<u>13.5</u>	<u>Changes to the Notice Information</u>	<u>26</u>
<u>Article 14.</u>	<u>Signatures</u>	<u>27</u>

Attachment 1 Glossary of Terms

Attachment 2 Description and Costs of the Small Generating Facility,
Interconnection Facilities, and Metering Equipment

Attachment 3 One-line Diagram Depicting the Small Generating Facility,
Interconnection Facilities, Metering Equipment, and Upgrades

Attachment 4 Milestones

Attachment 5 Additional Operating Requirements for the New York State
Transmission System, the Distribution System and Affected
Systems Needed to Support the Interconnection Customer's Needs

Attachment 6 Connecting Transmission Owner's Description of its Upgrades and Best
Estimate of Upgrade Costs

Attachment 7 Insurance Coverage

STANDARD SMALL GENERATOR INTERCONNECTION AGREEMENT

This Amended and Restated Interconnection Agreement (“Agreement” or “Amended Steel Winds IIA”) is made and entered into this ____ day of _____, 20__, by and among ~~the New York Independent System Operator, Inc., a~~ Niagara Mohawk Power Corporation d/b/a National Grid a corporation existing under the laws of the State of New York (“Connecting Transmission Owner”), Niagara Wind Power, LLC, a limited liability company organized and existing under the laws of the State of Delaware (“Interconnection Customer”) and Erie Wind, LLC a limited liability company organized and existing under the laws of the State of Delaware (“Erie Wind”) each ~~hereinafter not for profit corporation organized and existing under the laws of the State of New York (“NYISO”)~~ and _____ a _____ existing under the laws of the State of New York (“Connecting Transmission Owner”), and _____, a _____ organized and existing under the laws of the State of _____ (“Interconnection Customer”) each hereinafter sometimes referred to individually as “Party” or referred to collectively as the “Parties.”

NYISO Information

Attention:

Address:

City:

State: _____ Zip:

Phone:

Fax:

Connecting Transmission Owner Information

Connecting Transmission Owner: Niagara Mohawk Power Corporation, d/b/a

Attention:

Address:

National Grid

Attention:

Director, Transmission Commercial Services

Address:

300 Erie Boulevard West

City:

Syracuse

State: New York

Zip: 13202

Phone:

(781) 907-2422

Fax:

(781) 907-5707

Interconnection Customer Information

Interconnection Customer: Niagara Wind Power, LLC

Attention:

Legal Department

Address:

179 Lincoln Street, Suite 500

~~Interconnection Customer:~~

Attention:

Address:

City:

Boston

State: MA

Zip: 02111

Phone:

(617) 960-2888

Fax:

(617) 960-2889

Interconnection Customer Application No: _____

WHEREAS, by letter order dated March 31, 2006, the Federal Energy Regulatory Commission (“FERC”) accepted for filing in Docket No. ER06-694-000, Original Service Agreement No. 914 between Niagara Mohawk Corporation d/b/a National Grid and Steel Winds, LLC (“Original Steel Winds I IA”) to address the interconnection of the 20 MW wind generation plant (“Small Generating Facility” or “Steel Winds I wind generation plant”);

WHEREAS, Niagara Wind Power, LLC is the current owner of the Steel Winds I wind generation plant and currently interconnects its Steel Winds I wind generation plant to the Connecting Transmission Owner’s Transmission System through facilities located at an Existing Collection Station as described in the Original Steel Winds I IA;

WHEREAS, Erie Wind, LLC, will own and construct a 15 MW wind generation plant (“Steel Winds II”) as described in Attachment 2;

WHEREAS, the certain modifications to the facilities located at the Existing Collection Station that are described in Attachment 2 to this Agreement are necessary to effectuate the interconnection of Erie Wind, LLC’s Steel Winds II Plant and are included in the definition of “Jointly Owned Interconnection Facilities” set forth in Attachment 1 of this Agreement;

WHEREAS, both Niagara Wind Power, LLC and Erie Wind, LLC will have an undivided ownership interest in the Jointly Owned Interconnection Facilities described in Attachment 2 to this Agreement that will be constructed and installed at the Existing Collection Station to enable the interconnection of both the Steel Winds I and the Steel Winds II wind generation plants to the Connecting Transmission Owner’s Transmission System;

WHEREAS, the Original Steel Winds I IA is being revised to reflect this undivided ownership interest in the Jointly Owned Interconnection Facilities and to add Erie Wind, LLC as a party to the Amended Steel Winds I IA;

WHEREAS, Niagara Mohawk Corporation d/b/a National Grid, Erie Wind, LLC, Niagara Wind Power, LLC and the New York Independent System Operator, Inc. (“NYISO”) are parties to a Small Generator Interconnection Agreement to address the interconnection of the Steel Winds II Plant to the Connecting Transmission Owner’s Transmission System (“Steel Winds II IA”);

WHEREAS, Erie Wind, LLC will have a sole ownership interest in certain additional Interconnection Facilities described in Attachment 2 to this Agreement that will be constructed and installed to enable the interconnection of the Steel Winds II wind generation plant to the Connecting Transmission Owner’s Transmission System;

WHEREAS both Niagara Wind Power, LLC and Erie Wind, LLC have agreed to install certain Jointly Owned Interconnection Facilities necessary for compliance with the operating requirements of the Interim Constrained Operation Period, as such Interconnection Facilities are defined in Attachment 2 to this Agreement;

WHEREAS, both Niagara Wind Power, LLC and Erie Wind, LLC have agreed that the delivered output of the combined Steel Winds I and the Steel Winds II wind generation plants will not exceed 10 MW on each of the Lines 149 and 150 during the Interim Constrained Operations Period prior to the System Upgrade Facilities and Connecting Transmission Owner Interconnection Facilities being in service;

WHEREAS, Niagara Wind Power, LLC and Erie Wind, LLC both have agreed to have Niagara Wind Power, LLC be the Operational Contact and billing contact among the Parties under the two Interconnection Agreements for the Steel Winds I and Steel Wind II facilities; and

WHEREAS, Niagara Wind Power, LLC and Erie Wind, LLC have entered into a separate ownership agreement over the Jointly Owned Interconnection Facilities, such agreement shall govern the responsibilities of these two entities with regard to their ownership of these facilities, but in no way limits either party's responsibilities under this Agreement or the Amended Steel Winds I IA and any subsequent amendments thereto

NOW THEREFORE, In consideration of the mutual covenants set forth herein, the Parties agree as follows:

Article 1 Scope and Limitations of Agreement

1.1 Applicability

This Small Generator Interconnection Agreement (“SGIA”) shall be used for all Interconnection Requests submitted under the Small Generator Interconnection Procedures (SGIP) except for those submitted under the 10 kW Inverter Process contained in SGIP Attachment 5.

1.2 Purpose

This Agreement governs the terms and conditions under which the Interconnection Customer’s Small Generating Facility will interconnect with, and operate in parallel with, the New York State Transmission System or the Distribution System. This Agreement also governs certain terms and conditions related to the Jointly Owned Interconnection Facilities.

1.3 Scope of Interconnection Service

1.3.1 ~~NYISO~~ The Connecting Transmission Owner will provide ~~Energy Resource~~ Interconnection Service to Interconnection Customer at the Point of Interconnection.

1.3.2 This Agreement does not constitute an agreement to purchase or deliver the Interconnection Customer’s power. The purchase or delivery of power and other services that the Interconnection Customer may require will be covered under separate agreements, if any, or applicable provisions of NYISO’s or Connecting Transmission Owner’s tariffs. The Interconnection Customer will be responsible for separately making all necessary arrangements (including scheduling) for delivery of electricity in accordance with the applicable provisions of the NYISO OATT and Connecting Transmission Owner’s tariff. The execution of this Agreement does not constitute a request for, nor agreement to, provide energy, any Ancillary Services or Installed Capacity under the NYISO Services Tariff or any Connecting Transmission Owner’s tariff. If Interconnection Customer wishes to supply or purchase energy, Installed Capacity or Ancillary Services, then Interconnection Customer will make application to do so in accordance with the NYISO Services Tariff or Connecting Transmission Owner’s tariff.

1.4 Limitations

Nothing in this Agreement is intended to affect any other agreement by and among the NYISO, Connecting Transmission Owner, Erie Wind, and the Interconnection Customer, except as otherwise expressly provided herein.

1.5 Responsibilities of the Parties

- 1.5.1 The Parties shall perform all obligations of this Agreement in accordance with all Applicable Laws and Regulations, Operating Requirements, and Good Utility Practice.
- 1.5.2 The Interconnection Customer shall construct, interconnect, operate and maintain its Small Generating Facility and construct, operate, and maintain ~~its~~the Interconnection Facilities in accordance with the applicable manufacturer's recommended maintenance schedule, and in accordance with this Agreement, and with Good Utility Practice. The Interconnection Customer and Erie Wind shall construct, operate, and maintain the Jointly Owned Interconnection Facilities in accordance with the applicable manufacturer's recommended maintenance schedule, and in accordance with this Agreement, and with Good Utility Practice.
- 1.5.3 The Connecting Transmission Owner shall construct, operate, and maintain its Interconnection Facilities and Upgrades covered by this Agreement in accordance with this Agreement, and with Good Utility Practice.
- 1.5.4 The Interconnection Customer ~~agrees~~and Erie Wind agree to construct ~~its~~their facilities or systems in accordance with applicable specifications that meet or exceed those provided by the National Electrical Safety Code, the American National Standards Institute, IEEE, Underwriter's Laboratory, and Operating Requirements in effect at the time of construction and other applicable national and state codes and standards. The Interconnection Customer agrees to design, install, maintain, and operate its Small Generating Facility so as to reasonably minimize the likelihood of a disturbance adversely affecting or impairing the system or equipment of the Connecting Transmission Owner or Affected Systems.
- 1.5.5 The Connecting Transmission Owner ~~and~~, the Interconnection Customer, and Erie Wind shall operate, maintain, repair, and inspect, and shall be fully responsible for the facilities that it now or subsequently may own unless otherwise specified in the Attachments to this Agreement. Each of those Parties shall be responsible for the safe installation, maintenance, repair and condition of their respective lines and appurtenances on their respective sides of the point of change of ownership. The Connecting Transmission Owner ~~and~~, the Interconnection Customer, and Erie Wind, as appropriate, shall provide Interconnection Facilities and Jointly Owned Interconnection Facilities that adequately protect the Connecting Transmission Owner's electric system, personnel, and other persons from damage and injury. The allocation of responsibility for the design, installation, operation, maintenance and ownership of Interconnection Facilities and Jointly Owned Interconnection Facilities shall be delineated in the Attachments to this Agreement.
- 1.5.6 The ~~NYISO~~Connecting Transmission Owner shall coordinate with all Affected Systems to support the interconnection. ~~The Connecting Transmission Owner shall cooperate with the NYISO in these efforts.~~

1.5.7 Erie Wind authorizes the Connecting Transmission Owner to contact Niagara Wind Power as the "Operational Contact" for Erie Wind on issues related to the Small Generating Facility, the Interconnection Facilities, and the Jointly Owned Interconnection Facilities. This arrangement does not in any way excuse Erie Wind from any obligations applicable to it under this Agreement.

1.6 Parallel Operation Obligations

Once the Small Generating Facility has been authorized to commence parallel operation, the Interconnection Customer and Erie Wind shall abide by all rules and procedures pertaining to the parallel operation of the Small Generating Facility and the Jointly Owned Interconnection Facilities in the applicable control area, including, but not limited to; (1) the rules and procedures concerning the operation of generation set forth in the NYISO tariffs or ISO Procedures or the Connecting Transmission Owner's tariff; (2) any requirements consistent with Good Utility Practice or that are necessary to ensure the safe and reliable operation of the Transmission System or Distribution System; and (3) the Operating Requirements set forth in Attachment 5 of this Agreement.

1.7 Metering

The Interconnection Customer shall be responsible for the Connecting Transmission Owner's reasonable and necessary cost for the purchase, installation, operation, maintenance, testing, repair, and replacement of metering and data acquisition equipment specified in Attachments 2 and 3 of this Agreement. The Interconnection Customer's metering (and data acquisition, as required) equipment shall conform to applicable industry rules and Operating Requirements.

1.8 Reactive Power

1.8.1 The Interconnection Customer shall design its Small Generating Facility to maintain a composite power delivery at continuous rated power output at the Point of Interconnection at a power factor within the range established by the Connecting Transmission Owner on a comparable basis, until NYISO has established different requirements that apply to all similarly situated generators in the New York Control Area on a comparable basis.

1.8.2 The ~~NYISO~~Connecting Transmission Owner is required to pay the Interconnection Customer for reactive power, or voltage support service, that the Interconnection Customer provides from the Small Generating Facility in accordance with Rate Schedule 2 of the NYISO Services Tariff.

1.9 Interim Constrained Operation Period.

The Interim Constrained Operating Period will begin upon the Initial Synchronization Date of the Erie Wind Small Generating Facility and will terminate upon the earlier of (a) December 31, 2011 or (b) ten (10) Business Days after the System Upgrade Facilities and Interconnection Facilities are In Service. During the Interim Constrained Operation Period, the Interconnection Customer and Erie Wind shall ensure that the delivered output of the combined Steel Winds I and Steel Winds II Small Generating Facilities does not exceed 10 MW on each of the Lines 149 and 150. In accordance with Good Utility Practice, the Interconnection Customer and Erie Wind, LLC shall comply with all Operating Requirements deemed necessary for the Interim Constrained Operations Period.

~~1.9~~1.10 Capitalized Terms

Capitalized terms used herein shall have the meanings specified in the Glossary of Terms in Attachment 1 or the body of this Agreement. Capitalized terms used herein that are not so defined shall have the meanings specified in Section ~~32.1.01.0~~ or Attachment S or Attachment X of the NYISO OATT.

Article 2. Inspection, Testing, Authorization, and Right of Access

2.1 Equipment Testing and Inspection

2.1.1 The Interconnection Customer shall test and inspect its Small Generating Facility and Interconnection Facilities prior to interconnection. The Interconnection Customer and Erie Wind shall test and inspect its Jointly Owned Interconnection Facilities prior to interconnection. The Interconnection Customer and Erie Wind shall notify ~~the NYISO and~~ the Connecting Transmission Owner of such activities no fewer than five Business Days (or as may be agreed to by the Parties) prior to such testing and inspection. Testing and inspection shall occur on a Business Day. The Connecting Transmission Owner may, at its own expense, send qualified personnel to the Small Generating Facility site to inspect the interconnection and observe the testing. The Interconnection Customer and Erie Wind shall provide the ~~NYISO and~~ Connecting Transmission Owner a written test report when such testing and inspection is completed. The Small Generating Facility may not commence parallel operations if the ~~NYISO, in consultation with the~~ Connecting Transmission Owner, finds that the Small Generating Facility has, Interconnection Facilities, or Jointly Owned Interconnection Facilities have not been installed as agreed upon or may not be operated in a safe and reliable manner.

2.1.2 The ~~NYISO and~~ Connecting Transmission Owner shall ~~each~~ provide the Interconnection Customer written acknowledgment that it has received the ~~Interconnection Customer's~~ written test report of the Interconnection Customer and Erie Wind. Such written acknowledgment shall not be deemed to be or construed as any representation, assurance, guarantee, or warranty by the ~~NYISO or~~ Connecting Transmission Owner of the safety, durability, suitability, or reliability of the Small Generating Facility or any associated control, protective, and safety devices owned or controlled by the Interconnection Customer or Erie Wind or the quality of power produced by the Small Generating Facility.

2.2 Authorization Required Prior to Parallel Operation

2.2.1 ~~The NYISO, in consultation with~~ The Connecting Transmission Owner, shall use Reasonable Efforts to list applicable parallel Operating Requirements in Attachment 5 of this Agreement. Additionally, the ~~NYISO, in consultation with the~~ Connecting Transmission Owner, shall notify the Interconnection Customer of any changes to these requirements as soon as they are known. The ~~NYISO and~~ Connecting Transmission Owner shall make Reasonable Efforts to cooperate with the Interconnection Customer in meeting requirements necessary for the Interconnection Customer to commence parallel operations by the in-service date.

2.2.2 The Interconnection Customer shall not operate its Small Generating Facility in parallel with the New York State Transmission System or the Distribution System without prior written authorization of the ~~NYISO.~~ The NYISO, in consultation with Connecting Transmission Owner. The Connecting Transmission Owner, will provide such authorization once the ~~NYISO~~ Connecting Transmission Owner receives notification that the Interconnection Customer ~~has~~ and Erie Wind have complied with all applicable

parallel Operating Requirements. Such authorization shall not be unreasonably withheld, conditioned, or delayed.

2.3 Right of Access

- 2.3.1 Upon reasonable notice, the ~~NYISO and/or~~ Connecting Transmission Owner may send a qualified person to the premises of the Interconnection Customer and Erie Wind at or immediately before the time the Interconnection Facilities or Jointly Owned Interconnection Facilities are energized and immediately prior to the time the Small Generating Facility first produces energy to inspect the Interconnection Customer's Interconnection Facilities and the Jointly Owned Interconnection Facilities, and observe the commissioning of the Small Generating Facility (including any required testing), startup, and operation for a period of up to three Business Days after initial start-up of the unit. In addition, the Interconnection Customer and Erie Wind shall notify the ~~NYISO and~~ Connecting Transmission Owner at least five Business Days prior to conducting any on-site verification testing of the Small Generating Facility, Interconnection Facilities, or Jointly Owned Interconnection Facilities.
- 2.3.2 Following the initial inspection process described above, at reasonable hours, and upon reasonable notice, or at any time without notice in the event of an emergency or hazardous condition, the ~~NYISO and~~ Connecting Transmission Owner ~~each~~ shall have access to premises of the Interconnection Customer's premises Customer and Erie Wind for any reasonable purpose in connection with the performance of the obligations imposed on them by this Agreement or if necessary to meet their legal obligation to provide service to their customers.
- 2.3.3 Each Party shall be responsible for its own costs associated with following this article.

Article 3 Effective Date, Term, Termination, and Disconnection

3.1 Effective Date

This Agreement shall become effective upon execution by the Parties subject to acceptance by FERC (if applicable), or if filed unexecuted, upon the date specified by the FERC. The ~~NYISO and Connecting Transmission Owner~~ shall promptly file, or cause to be filed, this Agreement with FERC upon execution, if required. ~~If the Agreement is disputed and the Interconnection Customer requests that it be filed with FERC in an unexecuted form, the NYISO shall file, or cause to be filed, this Agreement and the NYISO shall identify the disputed language.~~

3.2 Term of Agreement

This Agreement shall become effective on the Effective Date and shall remain in effect for a period of ten years from the Effective Date or such other longer period as the Interconnection Customer may request and shall be automatically renewed for each successive one-year period thereafter, unless terminated earlier in accordance with article 3.3 of this Agreement.

3.3 Termination

No termination shall become effective until the Parties have complied with all Applicable Laws and Regulations applicable to such termination, including the filing with FERC of a notice of termination of this Agreement (if required), which notice has been accepted for filing by FERC.

3.3.1 The Interconnection Customer may terminate this Agreement at any time by giving the ~~NYISO and Connecting Transmission Owner~~ other Parties 20 Business Days written notice.

3.3.2 Any Party may terminate this Agreement after Default pursuant to article 7.6.

3.3.3 Upon termination of this Agreement, the Small Generating Facility will be disconnected from the ~~New York State Transmission System or the Distribution System, as applicable~~ Jointly Owned Interconnection Facilities. All costs required to effectuate such disconnection shall be borne by the terminating Party, unless such termination resulted from the non-terminating Party's Default of this SGIA or such non-terminating Party otherwise is responsible for these costs under this SGIA.

3.3.4 The termination of this Agreement shall not relieve any Party of its liabilities and obligations, owed or continuing at the time of the termination. The Interconnection Customer or Erie Wind shall pay all amounts in excess of any deposit or other security without interest within 30 calendar days after receipt of the invoice for such amounts. If the deposit or other security exceeds the invoice, the Connecting Transmission Owner shall refund such excess within 30 calendar days of the invoice without interest. If the Interconnection Customer or Erie Wind disputes an amount to be paid the Interconnection Customer or Erie Wind shall pay the disputed amount to the Connecting Transmission Owner or into an

interest bearing escrow account, pending resolution of the dispute in accordance with Article 10 of this Agreement. To the extent the dispute is resolved in the ~~Interconnection Customer's favor~~ favor of the Interconnection Customer or Erie Wind, that portion of the disputed amount will be returned to the Interconnection Customer or Erie Wind with interest at rates applicable to refunds under the Commission's regulations. To the extent the dispute is resolved in the Connecting Transmission Owner's favor, that portion of any escrowed funds and interest will be released to the Connecting Transmission Owner.

3.3.5 The limitations of liability, indemnification and confidentiality provisions of this Agreement shall survive termination or expiration of this Agreement.

3.3.6 Termination of this Interconnection Agreement should not affect the Steel Winds II IA, provided that the Connecting Transmission Owner reserves the right to file at the FERC to modify the Steel Winds II IA to reflect such termination or related changes in circumstances.

3.4 Temporary Disconnection

Temporary disconnection shall continue only for so long as reasonably necessary under Good Utility Practice.

3.4.1 Emergency Conditions

"Emergency Condition" shall mean a condition or situation: (1) that in the judgment of the Party making the claim is imminently likely to endanger life or property; or (2) that, in the case of the ~~NYISO or~~ Connecting Transmission Owner, is imminently likely (as determined in a non-discriminatory manner) to cause a material adverse effect on the security of, or damage to the New York State Transmission System or Distribution System, the Connecting Transmission Owner's Interconnection Facilities or the electric systems of others to which the New York State Transmission System or Distribution System is directly connected; or (3) that, in the case of the Interconnection Customer or Erie Wind, is imminently likely (as determined in a non-discriminatory manner) to cause a material adverse effect on the security of, or damage to, the Small Generating Facility or the Interconnection Customer's Interconnection Facilities or the Jointly Owned Interconnection Facilities. Under Emergency Conditions, the ~~NYISO or~~ Connecting Transmission Owner may immediately suspend interconnection service and temporarily disconnect the Small Generating Facility- ~~The NYISO or~~ or the Jointly Owned Interconnection Facilities from the New York State Transmission System or Distribution System. The Connecting Transmission Owner shall notify the Interconnection Customer promptly when it becomes aware of an Emergency Condition that may reasonably be expected to affect the Interconnection Customer's operation of the Small Generating Facility. The Interconnection Customer shall notify the ~~NYISO and~~ Connecting Transmission Owner promptly when it becomes aware of an Emergency Condition that may reasonably be expected to affect the New York State Transmission System or Distribution System or any Affected Systems. To the extent information is known, the notification shall describe the Emergency Condition, the extent of the damage or deficiency, the expected effect on the

operation of each Party's facilities and operations, its anticipated duration, and the necessary corrective action.

3.4.2 Routine Maintenance, Construction, and Repair

The ~~NYISO or~~ Connecting Transmission Owner may interrupt interconnection service or curtail the output of the Small Generating Facility and temporarily disconnect the Small Generating Facility, the Interconnection Facilities, or the Jointly Owned Interconnection Facilities from the New York State Transmission System or Distribution System when necessary for routine maintenance, construction, and repairs on the New York State Transmission System or Distribution System. ~~NYISO or~~ The Connecting Transmission Owner shall provide the Interconnection Customer with five Business Days notice prior to such interruption. The ~~NYISO and~~ Connecting Transmission Owner shall use Reasonable Efforts to coordinate such reduction or temporary disconnection with the Interconnection Customer, both in its capacity as the Interconnection Customer, and as the Operational Contact for Erie Wind.

3.4.3 Forced Outages

During any forced outage, the ~~NYISO or~~ Connecting Transmission Owner may suspend interconnection service to the Interconnection Customer to effect immediate repairs on the New York State Transmission System or the Distribution System. The ~~NYISO~~ Connecting Transmission Owner shall use Reasonable Efforts to provide the Interconnection Customer with prior notice. If prior notice is not given, the ~~NYISO~~ Connecting Transmission Owner shall, upon request, provide the Interconnection Customer written documentation after the fact explaining the circumstances of the disconnection.

3.4.4 Adverse Operating Effects

The ~~NYISO or~~ Connecting Transmission Owner shall notify the Interconnection Customer as soon as practicable if, based on Good Utility Practice, operation of the Small Generating Facility may cause disruption or deterioration of service to other customers served from the same electric system, or if operating the Small Generating Facility could cause damage to the New York State Transmission System, the Distribution System or Affected Systems, or if disconnection is otherwise required under Applicable Reliability Standards or the NYISO OATT. Supporting documentation used to reach the decision to disconnect shall be provided to the Interconnection Customer upon request. If, after notice, the Interconnection Customer or Erie Wind fails to remedy the adverse operating effect within a reasonable time, the ~~NYISO or~~ Connecting Transmission Owner may disconnect the Small Generating Facility. ~~The NYISO or, the~~ Interconnection Facilities, or the Jointly Owned Interconnection Facilities. The Connecting Transmission Owner shall provide the Interconnection Customer with five Business ~~Day~~ Days notice of such disconnection, unless the provisions of article 3.4.1 apply.

3.4.5 Modification of the Small Generating Facility, the Interconnection Facilities, or the Jointly Owned Interconnection Facilities

The Interconnection Customer or Erie Wind as applicable must receive written authorization from the ~~NYISO and~~ Connecting Transmission Owner before making any change to the Small Generating Facility, the Interconnection Facilities, or the Jointly Owned Interconnection Facilities, that may have a material impact on the safety or reliability of the New York State Transmission System or the Distribution System. Such authorization shall not be unreasonably withheld. Modifications shall be done in accordance with Good Utility Practice. If the Interconnection Customer or Erie Wind makes such modification without the prior written authorization of the ~~NYISO and~~ Connecting Transmission Owner, the Connecting Transmission Owner shall have the right to temporarily disconnect the Small Generating Facility, the Interconnection Facilities, or the Jointly Owned Interconnection Facilities. If disconnected, the Small Generating Facility, the Interconnection Facilities, or the Jointly Owned Interconnection Facilities will not be reconnected until the unauthorized modifications are authorized or removed.

3.4.6 Reconnection

The Parties shall cooperate with each other to restore the Small Generating Facility, Interconnection Facilities, Jointly Owned Interconnection Facilities, and the New York State Transmission System and Distribution System to their normal operating state as soon as reasonably practicable following a temporary disconnection.

Article 4. Cost Responsibility for Interconnection Facilities and Distribution Upgrades

4.1 Interconnection Facilities

4.1.1 The Interconnection Customer shall pay for the cost of the Interconnection Facilities itemized in Attachment 2 of this Agreement. ~~The NYISO, in consultation with~~ Interconnection Customer and Erie Wind shall be jointly and severally liable for the cost of the modifications to the Jointly Owned Interconnection Facilities itemized in Attachment 2 of this Agreement. The Connecting Transmission Owner, shall provide a best estimate cost, including overheads, for the purchase and construction of its Interconnection Facilities and the modifications to the Jointly Owned Interconnection Facilities and provide a detailed itemization of such costs. Costs associated with Interconnection Facilities and the Jointly Owned Interconnection Facilities may be shared with other entities that may benefit from such facilities by agreement of the Interconnection Customer, Erie Wind, such other entities, ~~the NYISO~~, and the Connecting Transmission Owner.

4.1.2 The Interconnection Customer and Erie Wind shall be jointly responsible for ~~its~~their share of all reasonable expenses, including overheads, associated with (1) owning, operating, maintaining, repairing, and replacing its own Interconnection Facilities; and the Jointly Owned Interconnection Facilities and (2) operating, maintaining, repairing, and replacing the Connecting Transmission Owner's Interconnection Facilities, as set forth in Attachment 2 to this Agreement.

4.2 Distribution Upgrades

The Connecting Transmission Owner shall design, procure, construct, install, and own the Distribution Upgrades described in Attachment 6 of this Agreement. If the Connecting Transmission Owner ~~and~~, the Interconnection Customer, and/or Erie Wind agree, the Interconnection Customer may construct Distribution Upgrades that are located on land owned by the Interconnection Customer or Erie Wind. The actual cost of the Distribution Upgrades, including overheads, shall be directly assigned to the Interconnection Customer and/or Erie Wind. The Interconnection Customer and Erie Wind shall be responsible for ~~its~~their share of all reasonable expenses, including overheads, associated with owning, operating, maintaining, repairing, and replacing the Distribution Upgrades, as set forth in Attachment 6 to this Agreement.

Article 5. Cost Responsibility for System Upgrade Facilities and System Deliverability Upgrades

5.1 Applicability

No portion of this article 5 shall apply unless the interconnection of the Small Generating Facility requires System Upgrade Facilities or System Deliverability Upgrades.

5.2 System Upgrades

The Connecting Transmission Owner shall procure, construct, install, and own the System Upgrade Facilities and System Deliverability Upgrades described in Attachment 6 of this Agreement. To the extent that design work is necessary in addition to that already accomplished in the Class Year facilities study for the Interconnection Customer, the Connecting Transmission Owner shall perform or cause to be performed such work. If all the Parties agree, the Interconnection Customer or Erie Wind may construct System Upgrade Facilities and System Deliverability Upgrades that are located on land owned by the Interconnection Customer or Erie Wind.

5.2.1 As described in Section ~~32.3.5.33.5.3~~ of the SGIP in Attachment Z of the NYISO OATT, the responsibility of the Interconnection Customer for the cost of the System Upgrade Facilities and System Deliverability Upgrades described in Attachment 6 of this Agreement shall be determined in accordance with Attachment S of the NYISO OATT. The Interconnection Customer shall be responsible for its share of any such costs resulting from the final Attachment S process, and Attachment 6 to this Agreement shall be revised accordingly.

5.2.2 Pending the outcome of the Attachment S cost allocation process, the Interconnection Customer may elect to proceed with the interconnection of its Small Generating Facility in accordance with Section ~~32.3.5.33.5.3~~ of the SGIP.

5.3 Special Provisions for Affected Systems

For the repayment of amounts advanced to Affected System Operator for System Upgrade Facilities or System Deliverability Upgrades, the Interconnection Customer and Affected System Operator shall enter into an agreement that provides for such repayment, but only if responsibility for the cost of such System Upgrade Facilities is not to be allocated in accordance with Attachment S of the NYISO OATT. The agreement shall specify the terms governing payments to be made by the Interconnection Customer to Affected System operator as well as the repayment by Affected System Operator.

Article 6. Billing, Payment, Milestones, and Financial Security

6.1 Billing and Payment Procedures and Final Accounting

- 6.1.1 The Connecting Transmission Owner shall bill the Interconnection Customer in both its capacity as the Interconnection Customer and as the Operational Contact for Erie Wind designated under this Agreement, for the design, engineering, construction, and procurement costs of the Interconnection Facilities and the required modifications to the Jointly Owned Interconnection Facilities and Upgrades contemplated by this Agreement on a monthly basis, or as otherwise agreed by those Parties. The Interconnection Customer shall pay all invoice amounts within 30 calendar days after receipt of the invoice. This billing arrangement does not in any way excuse Erie Wind from any responsibility for costs pursuant to this Agreement. The Interconnection Customer and Erie Wind shall remain jointly and severally liable for all amounts owed to the Connecting Transmission Owner under this Agreement for services and equipment provided related to the Jointly Owned Interconnection Facilities.
- 6.1.2 Within three months of completing the construction and installation of the Connecting Transmission Owner's Interconnection Facilities and/or Upgrades described in the Attachments to this Agreement, the Connecting Transmission Owner shall provide the Interconnection Customer with a final accounting report of any difference between (1) the Interconnection Customer's cost responsibility for the actual cost of such facilities or Upgrades, and (2) the Interconnection Customer's previous aggregate payments to the Connecting Transmission Owner for such facilities or Upgrades. If the Interconnection Customer's cost responsibility exceeds its previous aggregate payments, the Connecting Transmission Owner shall invoice the Interconnection Customer for the amount due and the Interconnection Customer shall make payment to the Connecting Transmission Owner within 30 calendar days. If the Interconnection Customer's previous aggregate payments exceed its cost responsibility under this Agreement, the Connecting Transmission Owner shall refund to the Interconnection Customer an amount equal to the difference within 30 calendar days of the final accounting report.
- 6.1.3 If the Interconnection Customer or Erie Wind disputes an amount to be paid, the Interconnection Customer or Erie Wind shall pay the disputed amount to the Connecting Transmission Owner or into an interest bearing escrow account, pending resolution of the dispute in accordance with Article 10 of this Agreement. To the extent the dispute is resolved in the ~~Interconnection Customer's favor~~ favor of the Interconnection Customer or Erie Wind, that portion of the disputed amount will be credited or returned to the Interconnection Customer or Erie Wind with interest at rates applicable to refunds under the Commission's regulations. To the extent the dispute is resolved in the Connecting Transmission Owner's favor, that portion of any escrowed funds and interest will be released to the Connecting Transmission Owner.

6.2 Milestones

Subject to the provisions of the SGIP, the Parties shall agree on milestones for which each Party is responsible and list them in Attachment 4 of this Agreement. A Party's obligations under this provision may be extended by agreement. If a Party anticipates that it will be unable to meet a milestone for any reason other than a Force Majeure event, it shall immediately notify the other Parties of the reason(s) for not meeting the milestone and (1) propose the earliest reasonable alternate date by which it can attain this and future milestones, and (2) requesting appropriate amendments to Attachment 4. The Party affected by the failure to meet a milestone shall not unreasonably withhold agreement to such an amendment unless it will suffer significant uncompensated economic or operational harm from the delay, (1) attainment of the same milestone has previously been delayed, or (2) it has reason to believe that the delay in meeting the milestone is intentional or unwarranted notwithstanding the circumstances explained by the Party proposing the amendment.

6.3 Financial Security Arrangements

At least 20 Business Days prior to the commencement of the design, procurement, installation, or construction of a discrete portion of the Connecting Transmission Owner's Interconnection Facilities and Upgrades, the Interconnection Customer shall provide the Connecting Transmission Owner, at the Interconnection Customer's option, a guarantee, a surety bond, letter of credit or other form of security that is reasonably acceptable to the Connecting Transmission Owner and is consistent with the Uniform Commercial Code of the jurisdiction where the Point of Interconnection is located. Such security for payment shall be in an amount sufficient to cover the costs for constructing, designing, procuring, and installing the applicable portion of the Connecting Transmission Owner's Interconnection Facilities and Upgrades and shall be reduced on a dollar-for-dollar basis for payments made to the Connecting Transmission Owner under this Agreement during its term. The Connecting Transmission Owner may draw on any such security to the extent that the Interconnection Customer fails to make any payments due under this Agreement. In addition:

- 6.3.1 The guarantee must be made by an entity that meets the creditworthiness requirements of the Connecting Transmission Owner, and contain terms and conditions that guarantee payment of any amount that may be due from the Interconnection Customer, up to an agreed-to maximum amount.
- 6.3.2 The letter of credit or surety bond must be issued by a financial institution or insurer reasonably acceptable to the Connecting Transmission Owner and must specify a reasonable expiration date.
- 6.3.3 Security posted for System Upgrade Facilities, or cash or Security provided for System Deliverability Upgrades, shall meet the requirements for Security contained in Attachment S to the NYISO OATT.

Article 7. Assignment, Liability, Indemnity, Force Majeure, Consequential Damages, and Default

7.1 Assignment

This Agreement, and each and every term and condition hereof, shall be binding upon and inure to the benefit of the Parties hereto and their respective successors and assigns. This Agreement may be assigned by any Party upon 15 Business Days prior written notice and opportunity to object by the other Parties; provided that:

7.1.1 A Party may assign this Agreement without the consent of the other Parties to any affiliate of the assigning Party with an equal or greater credit rating and with the legal authority and operational ability to satisfy the obligations of the assigning Party under this Agreement, provided that the Interconnection Customer ~~and Erie Wind are required to promptly notifies the NYISO and the Connecting Transmission Owner~~ notify the other Parties of any such assignment. A Party may assign this Agreement without the consent of the other Parties in connection with the sale, merger, restructuring, or transfer of a substantial portion of all of its assets, including the Interconnection Facilities or Jointly Owned Interconnection Facilities it owns, so long as the assignee in such a transaction directly assumes all rights, duties and obligation arising under this Agreement.

7.1.2 The Interconnection Customer shall have the right to assign this Agreement, without the consent of the ~~NYISO or Connecting Transmission Owner~~ other Parties, for collateral security purposes to aid in providing financing for the Small Generating Facility.

7.1.3 Any attempted assignment that violates this article is void and ineffective. Assignment shall not relieve a Party of its obligations, nor shall a Party's obligations be enlarged, in whole or in part, by reason thereof. An assignee is responsible for meeting the same financial, credit, and insurance obligations as the Interconnection Customer. Where required, consent to assignment will not be unreasonably withheld, conditioned or delayed.

7.2 Limitation of Liability

Each Party's liability to the other Parties for any loss, cost, claim, injury, liability, or expense, including reasonable attorney's fees, relating to or arising from any act or omission in its performance of this Agreement, shall be limited to the amount of direct damage actually incurred. In no event shall any Party be liable to the other Parties for any indirect, special, consequential, or punitive damages.

7.3 Indemnity

- 7.3.1 This provision protects each Party from liability incurred to third parties as a result of carrying out the provisions of this Agreement. Liability under this provision is exempt from the general limitations on liability found in article 7.2.
- 7.3.2 Each Party (the “Indemnifying Party”) shall at all times indemnify, defend, and hold harmless the other Parties (each an “ Indemnified Party”) from, any and all damages, losses, claims, including claims and actions relating to injury to or death of any person or damage to property, the alleged violation of any Environmental Law, or the release or threatened release of any Hazardous Substance, demand, suits, recoveries, costs and expenses, court costs, attorney fees, and all other obligations by or to third parties (any and all of these a “Loss”), arising out of or resulting from (i) the Indemnified Party’s performance under this Agreement on behalf of the Indemnifying Party, except in cases where the Indemnifying Party can demonstrate that the Loss of the Indemnified Party was caused by the gross negligence or intentional wrongdoing by the Indemnified Party or (ii) the violation by the Indemnifying Party of any Environmental Law or the release by the Indemnifying Party of a Hazardous Substance.
- 7.3.3 If a Party is entitled to indemnification under this article as a result of a claim by a third party, and the Indemnifying Party fails, after notice and reasonable opportunity to proceed under this article, to assume the defense of such claim, such Indemnified Party may at the expense of the Indemnifying Party contest, settle or consent to the entry of any judgment with respect to, or pay in full, such claim.
- 7.3.4 If an Indemnifying Party is obligated to indemnify and hold any Indemnified Party harmless under this article, the amount owing to the Indemnified Party shall be the amount of such Indemnified Party’s actual loss, net of any insurance or other recovery.
- 7.3.5 Promptly after receipt by an Indemnified Party of any claim or notice of the commencement of any action or administrative or legal proceeding or investigation as to which the indemnity provided for in this article may apply, the Indemnified Party shall notify the Indemnifying Party of such fact. Any failure of or delay in such notification shall not affect a Party’s indemnification obligation unless such failure or delay is materially prejudicial to the Indemnifying Party.

7.4 Consequential Damages

Other than as expressly provided for in this Agreement, no Party shall be liable under any provision of this Agreement for any losses, damages, costs or expenses for any special, indirect, incidental, consequential, or punitive damages, including but not limited to loss of

profit or revenue, loss of the use of equipment, cost of capital, cost of temporary equipment or services, whether based in whole or in part in contract, in tort, including negligence, strict liability, or any other theory of liability; provided, however, that damages for which a Party may be liable to another Party under another agreement will not be considered to be special, indirect, incidental, or consequential damages hereunder.

7.5 Force Majeure

7.5.1 As used in this article, a Force Majeure Event shall mean “any act of God, labor disturbance, act of the public enemy, war, insurrection, riot, fire, storm or flood, explosion, breakage or accident to machinery or equipment, any order, regulation or restriction imposed by governmental, military or lawfully established civilian authorities, or any other cause beyond a Party’s control. A Force Majeure Event does not include an act of negligence or intentional wrongdoing.” For the purposes of this article, this definition of Force Majeure shall supersede the definitions of Force Majeure set out in Section ~~32-10.1~~10.1 of the NYISO OATT.

7.5.2 If an event of Force Majeure prevents a Party from fulfilling any obligations under this Agreement, the Party affected by the Force Majeure event (Affected Party) shall promptly notify the other Parties, either in writing or via the telephone, of the existence of the Force Majeure event. The notification must specify in reasonable detail the circumstances of the Force Majeure event, its expected duration, and the steps that the Affected Party is taking to mitigate the effects of the event on its performance. The Affected Party shall keep the other Parties informed on a continuing basis of developments relating to the Force Majeure event until the event ends. The Affected Party will be entitled to suspend or modify its performance of obligations under this Agreement (other than the obligation to make payments) only to the extent that the effect of the Force Majeure event cannot be mitigated by the use of Reasonable Efforts. The Affected Party will use Reasonable Efforts to resume its performance as soon as possible.

7.6 Breach and Default

7.6.1 No Breach of this Agreement shall exist where such failure to discharge an obligation (other than the payment of money) is the result of a Force Majeure event or the result of an act or omission of the other Parties, provided that a Breach of this Agreement by the Interconnection Customer or Erie Wind shall not be excused by the act or omission of the other. Upon a Breach, the non-breaching Party shall give written notice of such Breach to the Breaching Party. Except as provided in article 7.6.2, the Breaching Party shall have 60 calendar days from receipt of the Breach notice within which to cure such Breach; provided however, if such Breach is not capable of cure within 60 calendar days, the Breaching Party shall commence such cure within 20 calendar days after notice and continuously and diligently complete such cure within six months from receipt of the Breach notice; and, if cured within such time, the Breach specified in such notice shall cease to exist.

7.6.2 If a Breach is not cured as provided in this article, or if a Breach is not capable of being cured within the period provided for herein, a Default shall exist and

the non-defaulting Parties acting together shall thereafter have the right to terminate this Agreement, in accordance with article 3.3 hereof, by written notice to the Defaulting Party at any time until cure occurs, and be relieved of any further obligation hereunder and, whether or not those Parties terminate this Agreement, to recover from the Defaulting Party all amounts due hereunder, plus all other damages and remedies to which they are entitled at law or in equity. The provisions of this article shall survive termination of this Agreement.

- 7.6.3 In cases where the Interconnection Customer has elected to proceed under Section ~~32.3.5~~33.5.3 of the SGIP, if the Interconnection Request is withdrawn or deemed withdrawn pursuant to the SGIP during the term of this Agreement, this Agreement shall terminate.

7.7 Liability of Interconnection Customer and Erie Wind.

Notwithstanding any other provisions in this Agreement, the Interconnection Customer and Erie Wind shall be jointly and severally liable for all obligations and responsibilities applicable to either of them under this Agreement related to the Jointly Owned Interconnection Facilities. The Interconnection Customer and Erie Wind are not jointly or severally liable under this Agreement to the Connecting Transmission Owner for any obligation or responsibility associated with the Small Generating Facility or for electricity commodity purchases from Connected Transmission Owner.

Article 8. Insurance

- 8.1 The Interconnection Customer and Erie Wind shall, at ~~its~~their own expense, maintain in force general liability insurance without any exclusion for liabilities related to the interconnection undertaken pursuant to this Agreement. The amount of such insurance shall be sufficient to insure against all reasonably foreseeable direct liabilities given the size and nature of the generating equipment being interconnected, the interconnection itself, and the characteristics of the system to which the interconnection is made. Such insurance coverage is specified in Attachment 7 to this Agreement. The Interconnection Customer and Erie Wind shall obtain additional insurance only if necessary as a function of owning and operating a generating facility or interconnection facilities. Such insurance shall be obtained from an insurance provider authorized to do business in New York State where the interconnection is located. Certification that such insurance is in effect shall be provided upon request of the Connecting Transmission Owner, except that the Interconnection Customer and Erie Wind shall show proof of insurance to the Connecting Transmission Owner no later than ten Business Days prior to the anticipated commercial operation date. An Interconnection Customer of sufficient creditworthiness may propose to self-insure for such liabilities, and such a proposal shall not be unreasonably rejected.
- 8.2 The ~~NYISO and~~ Connecting Transmission Owner ~~agree~~agrees to maintain general liability insurance or self-insurance consistent with the existing commercial practice. Such insurance or self-insurance shall not exclude the liabilities undertaken pursuant to this Agreement.
- 8.3 The Parties further agree to notify one another whenever an accident or incident occurs resulting in any injuries or damages that are included within the scope of coverage of such insurance, whether or not such coverage is sought.

Article 9. Confidentiality

9.1 Confidential Information shall mean any confidential and/or proprietary information provided by one Party to the other Party that is clearly marked or otherwise designated “Confidential.” For purposes of this Agreement all design, operating specifications, and metering data provided by the Interconnection Customer shall be deemed Confidential Information regardless of whether it is clearly marked or otherwise designated as such. Confidential Information shall include, without limitation, information designated as such by the NYISO Code of Conduct contained in Attachment F to the NYISO OATT.

9.2 Confidential Information does not include information previously in the public domain, required to be publicly submitted or divulged by Governmental Authorities (after notice to the other Party and after exhausting any opportunity to oppose such publication or release), or necessary to be divulged in an action to enforce this Agreement. Each Party receiving Confidential Information shall hold such information in confidence and shall not disclose it to any third party nor to the public without the prior written authorization from the Party providing that information, except to fulfill obligations under this Agreement, or to fulfill legal or regulatory requirements.

9.2.1 Each Party shall employ at least the same standard of care to protect Confidential Information obtained from the other Parties as it employs to protect its own Confidential Information.

9.2.2 Each Party is entitled to equitable relief, by injunction or otherwise, to enforce its rights under this provision to prevent the release of Confidential Information without bond or proof of damages, and may seek other remedies available at law or in equity for breach of this provision.

9.3 Notwithstanding anything in this article to the contrary, and pursuant to 18 CFR § 1b.20, if FERC, during the course of an investigation or otherwise, requests information from one of the Parties that is otherwise required to be maintained in confidence pursuant to this Agreement, the Party shall provide the requested information to FERC, within the time provided for in the request for information. In providing the information to FERC, the Party may, consistent with 18 CFR § 388.112, request that the information be treated as confidential and non-public by FERC and that the information be withheld from public disclosure. Each Party is prohibited from notifying the other Parties to this Agreement prior to the release of the Confidential Information to FERC. The Party shall notify the other Parties to this Agreement when it is notified by FERC that a request to release Confidential Information has been received by FERC, at which time either of the Parties may respond before such information would be made public, pursuant to 18 CFR § 388.112. Requests from a state regulatory body conducting a

confidential investigation shall be treated in a similar manner if consistent with the applicable state rules and regulations.

9.4 Consistent with the provisions of this article 9, the Parties to this Agreement will cooperate in good faith to provide each other, Affected Systems, Affected System Operators, and state and federal regulators the information necessary to carry out the terms of the SGIP and this Agreement.

Article 10. Disputes

- 10.1 The ~~NYISO, Connecting Transmission Owner and, Interconnection Customer, and Erie Wind~~ agree to attempt to resolve all disputes arising out of the interconnection process according to the provisions of this article.
- 10.2 In the event of a dispute, the Parties will first attempt to promptly resolve it on an informal basis. ~~The NYISO will be available to the Interconnection Customer and Connecting Transmission Owner to help resolve any dispute that arises with respect to performance under this Agreement.~~ If the Parties cannot promptly resolve the dispute on an informal basis, then any Party shall provide the other Parties with a written Notice of Dispute. Such Notice shall describe in detail the nature of the dispute.
- 10.3 If the dispute has not been resolved within two Business Days after receipt of the Notice, any Party may contact FERC's Dispute Resolution Service (DRS) for assistance in resolving the dispute.
- 10.4 The DRS will assist the Parties in either resolving their dispute or in selecting an appropriate dispute resolution venue (e.g., mediation, settlement judge, early neutral evaluation, or technical expert) to assist the Parties in resolving their dispute. The result of this dispute resolution process will be binding only if the Parties agree in advance. DRS can be reached at 1-877-337-2237 or via the internet at <http://www.ferc.gov/legal/adr.asp>.
- 10.5 Each Party agrees to conduct all negotiations in good faith and will be responsible for one-third of any costs paid to neutral third-parties.
- 10.6 If any Party elects to seek assistance from the DRS, or if the attempted dispute resolution fails, then any Party may exercise whatever rights and remedies it may have in equity or law consistent with the terms of this Agreement.

Article 11. Taxes

- 11.1 The Parties agree to follow all applicable tax laws and regulations, consistent with FERC policy and Internal Revenue Service requirements.
- 11.2 Each Party shall cooperate with the other Parties to maintain the other Parties' tax status. Nothing in this Agreement is intended to adversely affect the tax status of any Party-~~including the status of NYISO~~, or the status of any Connecting Transmission Owner with respect to the issuance of bonds including, but not limited to, Local Furnishing Bonds. Notwithstanding any other provisions of this Agreement, LIPA, NYPA and Consolidated Edison Company of New York, Inc. shall not be required to comply with any provisions of this Agreement that would result in the loss of tax-~~exempt~~ status of any of their Tax-~~Exempt~~ Bonds or impair their ability to issue future tax-~~exempt~~ obligations. For purposes of this provision, Tax-~~Exempt~~ Bonds shall include the obligations of the Long Island Power Authority, NYPA and Consolidated Edison Company of New York, Inc., the interest on which is not included in gross income under the Internal Revenue Code.
- 11.3 LIPA and NYPA do not waive their exemptions, pursuant to Section 201(f) of the FPA, from Commission jurisdiction with respect to the Commission's exercise of the FPA's general ratemaking authority.
- 11.4 Any payments due to the Connecting Transmission Owner under this Agreement shall be adjusted to include any tax liability incurred by the Connecting Transmission Owner with respect to the interconnection request which is the subject of this Agreement. Such adjustments shall be made in accordance with the provisions of Article 5.17 of the LGIA in Attachment X of the NYISO OATT. Except where otherwise noted, all costs, deposits, financial obligations and the like specified in this Agreement shall be assumed not to reflect the impact of applicable taxes.

Article 12. Miscellaneous

12.1 Governing Law, Regulatory Authority, and Rules

The validity, interpretation and enforcement of this Agreement and each of its provisions shall be governed by the laws of the state of New York, without regard to its conflicts of law principles. This Agreement is subject to all Applicable Laws and Regulations. Each Party expressly reserves the right to seek changes in, appeal, or otherwise contest any laws, orders, or regulations of a Governmental Authority.

12.2 Amendment

The Parties may amend this Agreement by a written instrument duly executed by the Parties, or under article 12.12 of this Agreement.

12.3 No Third-Party Beneficiaries

This Agreement is not intended to and does not create rights, remedies, or benefits of any character whatsoever in favor of any persons, corporations, associations, or entities other than the Parties, and the obligations herein assumed are solely for the use and benefit of the Parties, their successors in interest and where permitted, their assigns.

Notwithstanding the foregoing, any subcontractor of the Connecting Transmission Owner or NYISO assisting either of those Parties with the Interconnection Request covered by this Agreement shall be entitled to the benefits of indemnification provided for under Article 7.3 of this Agreement and the limitation of liability provided for in Article 7.2 of this Agreement.

12.4 Waiver

12.4.1 The failure of a Party to this Agreement to insist, on any occasion, upon strict performance of any provision of this Agreement will not be considered a waiver of any obligation, right, or duty of, or imposed upon, such Party.

12.4.2 Any waiver at any time by a Party of its rights with respect to this Agreement shall not be deemed a continuing waiver or a waiver with respect to any other failure to comply with any other obligation, right, duty of this Agreement. Termination or default of this Agreement for any reason by Interconnection Customer shall not constitute a waiver of the Interconnection Customer's legal rights to obtain an interconnection from the ~~NYISO~~Connecting Transmission Owner. Any waiver of this Agreement shall, if requested, be provided in writing.

12.5 Entire Agreement

This Agreement, including all Attachments, constitutes the entire agreement between the Parties with reference to the subject matter hereof, and supersedes all prior and contemporaneous understandings or agreements, oral or written, between the Parties with respect to the subject matter of this Agreement. There are no other agreements,

representations, warranties, or covenants which constitute any part of the consideration for, or any condition to, any Party's compliance with its obligations under this Agreement.

12.6 Multiple Counterparts

This Agreement may be executed in two or more counterparts, each of which is deemed an original but all constitute one and the same instrument.

12.7 No Partnership

This Agreement shall not be interpreted or construed to create an association, joint venture, agency relationship, or partnership between the Parties or to impose any partnership obligation or partnership liability upon any Party. Except as expressly provided for in this Agreement, no Party shall have any right, power or authority to enter into any agreement or undertaking for, or act on behalf of, or to act as or be an agent or representative of, or to otherwise bind, another Party.

12.8 Severability

If any provision or portion of this Agreement shall for any reason be held or adjudged to be invalid or illegal or unenforceable by any court of competent jurisdiction or other Governmental Authority, (1) such portion or provision shall be deemed separate and independent, (2) the Parties shall negotiate in good faith to restore insofar as practicable the benefits to each Party that were affected by such ruling, and (3) the remainder of this Agreement shall remain in full force and effect.

12.9 Security Arrangements

Infrastructure security of electric system equipment and operations and control hardware and software is essential to ensure day-to-day reliability and operational security. FERC expects the NYISO, the Connecting Transmission Owner, Market Participants, and interconnection customers interconnected to electric systems (including Erie Wind) to comply with the recommendations offered by the President's Critical Infrastructure Protection Board and, eventually, best practice recommendations from the electric reliability authority. All public utilities are expected to meet basic standards for system infrastructure and operational security, including physical, operational, and cyber-security practices.

12.10 Environmental Releases

Each Party shall notify the other Parties, first orally and then in writing, of the release of any hazardous substances, any asbestos or lead abatement activities, or any type of remediation activities related to the Small Generating Facility, the Jointly Owned Interconnection Facilities, or the Interconnection Facilities, each of which may reasonably be expected to affect the other Parties. The notifying Party shall (1) provide the notice as soon as practicable, provided such Party makes a good faith effort to provide the notice no later than 24 hours after such Party becomes aware of the occurrence, and (2) promptly furnish to the other Parties copies of any publicly available reports filed with any governmental authorities addressing such events.

12.11 Subcontractors

Nothing in this Agreement shall prevent a Party from utilizing the services of any subcontractor as it deems appropriate to perform its obligations under this Agreement; provided, however, that each Party shall require its subcontractors to comply with all applicable terms and conditions of this Agreement in providing such services and each Party shall remain primarily liable to the other Parties for the performance of such subcontractor.

12.11.1 The creation of any subcontract relationship shall not relieve the hiring Party of any of its obligations under this Agreement. The hiring Party shall be fully responsible to the other Parties to the extent provided for in Sections ~~32.7-27.2~~ and ~~32.7-37.3~~ above for the acts or omissions of any subcontractor the hiring Party hires as if no subcontract had been made; provided, however, that in no event shall the ~~NYISO or~~ Connecting Transmission Owner be liable for the actions or inactions of the Interconnection Customer or ~~its~~ Erie Wind or their subcontractors with respect to obligations of the Interconnection Customer or Erie Wind under this Agreement. Any applicable obligation imposed by this Agreement upon the hiring Party shall be equally binding upon, and shall be construed as having application to, any subcontractor of such Party.

12.11.2 The obligations under this article will not be limited in any way by any limitation of subcontractor's insurance.

12.12 Reservation of Rights

Nothing in this Agreement shall alter the right of the ~~NYISO or~~ Connecting Transmission Owner to make unilateral filings with FERC to modify this Agreement with respect to any rates, terms and conditions, charges, classifications of service, rule or regulation under Section 205 or any other applicable provision of the Federal Power Act and FERC's rules and regulations thereunder which rights are expressly reserved herein, and the existing rights of the Interconnection Customer or Erie Wind to make a unilateral filing with FERC to modify this Agreement under any applicable provision of the Federal Power Act and FERC's rules and regulations are also expressly reserved herein; provided that each Party shall have the right to protest any such filing by another Party and to participate fully in any proceeding before FERC in which such modifications may be considered. Nothing in this Agreement shall limit the rights of the Parties or of FERC under Sections 205 or 206 of the Federal Power Act and FERC's rules and regulations, except to the extent that the Parties otherwise agree as provided herein.

Article 13. Notices

13.1 General

Unless otherwise provided in this Agreement, any written notice, demand, or request required or authorized in connection with this Agreement (“Notice”) shall be deemed properly given if delivered in person, delivered by recognized national carrier service, or sent by first class mail, postage prepaid, to the person specified below:

If to the Interconnection Customer:

Interconnection Customer: Niagara Wind Power, LLC
c/o First Wind Energy
Attention: Legal Department
Address: 179 Lincoln Street, Suite 500
City: Boston State: MA Zip: 02111
Phone: (617) 960-2888 Fax: (617) 960-2889

If to Erie Wind:

Erie Wind, LLC
c/o First Wind Energy
Attention: Legal Department
Address: 179 Lincoln Street, Suite 500
City: Boston State: MA Zip: 02111
Phone: 617-960-2888 Fax: 617-960-2889

If to the Connecting Transmission Owner:

Connecting Transmission Owner: Niagara Mohawk Power Corporation, d/b/a
National Grid

Attention: Director, Transmission Commercial Services
Address: 300 Erie Boulevard West

Attention:
Address:
City: Syracuse State: New York Zip: 13202
Phone: (781) 907-2422 Fax: (781) 907-5707

Phone: Fax:

If to the NYISO:

Attention:
Address:
City: _____ State: _____ Zip:
Phone: _____ Fax: _____

13.2 Billing and Payment

Billings and payments shall be sent to the addresses set out below:

If to the Interconnection Customer:

Interconnection Customer: Niagara Wind Power, LLC
c/o First Wind Energy
Attention: Legal Department
Address: 179 Lincoln Street, Suite 500
City: Boston State: MA Zip: 02111
Phone: (617) 960-2888 Fax: (617) 960-2889

If to Erie Wind:

Erie Wind, LLC
c/o First Wind Energy
Attention: Legal Department
Address: 179 Lincoln Street, Suite 500
City: Boston State: MA Zip: 02111
Phone: 617-960-2888 Fax: 617-960-2889
Email: elim@firstwind.com

If to the Connecting Transmission Owner:

Attention:
Address:
Connecting Transmission Owner: Niagara Mohawk Power Corporation, d/b/a
National Grid
Attention: Transmission Billing
Address: West Wing, 2nd Floor
10 Sylvan Road
City: Waltham State: MA Zip: 02451
Phone: (781) 907-2221 Fax: (781) 907-5707

13.3 Alternative Forms of Notice

Any notice or request required or permitted to be given by either Party to the other and not required by this Agreement to be given in writing may be so given by telephone, facsimile or e-mail to the telephone numbers and e-mail addresses set out below:

If to the Interconnection Customer:

Interconnection Customer: Niagara Wind Power, LLC
c/o First Wind Energy
Attention: Legal Department
Address:
Address: 179 Lincoln Street, Suite 500
City: Boston State: MA Zip: 02111
Phone: (617) 960-2888 Fax: (617) 960-2889
Email: elim@firstwind.com

If to Erie Wind:

Erie Wind, LLC
c/o First Wind Energy
Attention: Legal Department

Address: 179 Lincoln Street, Suite 500
City: Boston State: MA Zip: 02111
Phone: 617-960-2888 Fax: 617-960-2889
Email: elim@firstwind.com

If to the Connecting Transmission Owner:

Connecting Transmission Owner:
Niagara Mohawk Power Corporation, d/b/a National Grid
Attention: Transmission Account Manager
Address: 300 Erie Boulevard West
City: Syracuse State: New York Zip: 13202
Phone: (315) 428-5047 Fax: (315) 428-5114

If to the NYISO:

Attention:

Address:

City: _____ State: _____ Zip:

Phone:

Fax:

13.4 Designated Operating Representative

The Parties may also designate operating representatives to conduct the communications which may be necessary or convenient for the administration of this Agreement. This person will also serve as the point of contact with respect to operations and maintenance of the Party’s facilities.

Interconnection Customer’s Operating Representative:

Interconnection Customer:

Interconnection Customer: Niagara Wind Power, LLC
Attention: Data Analysis Control Center (“DACC”)

Address: _____
City: _____ State: _____ Zip:
Phone: (951) 294-5613 Fax: NYISO Dedicated: (951) 296-5282
Email: DControlCenter@firstwind.com

Attention:

Address:

City: _____ State: _____ Zip:

Address:

City: _____ State: _____ Zip:

Phone:

Fax:

Transmission Provider's Operating Representative:

~~Transmission Provider:~~

Transmission Provider: Niagara Mohawk Power Corporation, d/b/a National

Grid

Attention: Transmission Account Manager

Address: 300 Erie Boulevard West

Address: City: Syracuse State: New York Zip: 13202

Phone: (315) 428-5047 Fax: (315) 428-5114

~~NYISO's Operating Representative:~~

Attention:

Address: City: _____ State: _____ Zip: _____

~~Phone: Fax:~~

13.5 Changes to the Notice Information

~~Either~~ Any Party may change this information by giving five Business Days written notice prior to the effective date of the change.

Article 14. Signatures

IN WITNESS WHEREOF, the Parties have caused this Agreement to be executed by their respective duly authorized representatives.

~~For the NYISO~~

~~Name:~~

~~Title:~~

~~Date:~~

For the Connecting Transmission Owner: Niagara Mohawk Power Corporation d/b/a National Grid

Name: ~~Title:~~

Title:

Date:

For the Niagara Wind Power, LLC, Interconnection Customer

Name: ~~Title:~~

Title:

Date:

For the Erie Wind, LLC, Niagara Interconnection Customer

Name:

Title:

Date:

~~Attachment 1~~—Glossary of Terms

Affected System – An electric system other than the transmission system owned, controlled or operated by the Connecting Transmission Owner that may be affected by the proposed interconnection.

Affected System Operator – Affected System Operator shall mean the operator of any Affected System.

Affected Transmission Owner -- The New York public utility or authority (or its designated agent) other than the Connecting Transmission Owner that (i) owns facilities used for the transmission of Energy in interstate commerce and provides Transmission Service under the Tariff, and (ii) owns, leases or otherwise possesses an interest in a portion of the New York State Transmission System where System Deliverability Upgrades or System Upgrade Facilities are installed pursuant to Attachment Z and Attachment S to the NYISO OATT.

Applicable Laws and Regulations – All duly promulgated applicable federal, state and local laws, regulations, rules, ordinances, codes, decrees, judgments, directives, or judicial or administrative orders, permits and other duly authorized actions of any Governmental Authority, including but not limited to Environmental Law.

Applicable Reliability Standards – The criteria, requirements and guidelines of the North American Electric Reliability Council, the Northeast Power Coordinating Council, the New York State Reliability Council and related and successor organizations, or the Transmission District to which the Interconnection Customer's Small Generating Facility is directly interconnected, as those criteria, requirements and guidelines are amended and modified and in effect from time to time; provided that no Party shall waive its right to challenge the applicability of or validity of any criterion, requirement or guideline as applied to it in the context of Attachment Z to the NYISO OATT and this Agreement. For the purposes of this Agreement, this definition of Applicable Reliability Standards shall supersede the definition of Applicable Reliability Standards set out in Attachment X to the NYISO OATT.

Base Case -- The base case power flow, short circuit, and stability data bases used for the Interconnection Studies by NYISO, Connecting Transmission Owner or Interconnection Customer; described in Section ~~32.2.3~~32.3 of the Large Facility Interconnection Procedures.

Breach -- The failure of a Party to perform or observe any material term or condition of this Agreement.

Business Day – Monday through Friday, excluding federal holidays.

Capacity Resource Interconnection Service -- The service provided by NYISO to interconnect the Interconnection Customer's Small Generating Facility to the New York State Transmission System or Distribution System in accordance with the NYISO Deliverability Interconnection

Standard, to enable the New York State Transmission System to deliver electric capacity from the Small Generating Facility, pursuant to the terms of the NYISO OATT.

Connecting Transmission Owner – The New York public utility or authority (or its designated agent) that (i) owns facilities used for the transmission of Energy in interstate commerce and provides Transmission Service under the Tariff, (ii) owns, leases or otherwise possesses an interest in the portion of the New York State Transmission System or Distribution System at the Point of Interconnection, and (iii) is a Party to the Standard Small Generator Interconnection Agreement.

Deliverability Interconnection Standard – The standard that must be met by any Small Generating Facility larger than 2MW proposing to interconnect to the New York State Transmission System or Distribution System and to become a qualified Installed Capacity Supplier, and must be met by any merchant transmission project proposing to interconnect to the New York State Transmission System and receive Unforced Capacity Delivery Rights. To meet the NYISO Deliverability Interconnection Standard, the Interconnection Customer must, in accordance with the rules in Attachment S to the NYISO OATT, fund or commit to fund the System Deliverability Upgrades identified for its project in the Class Year Deliverability Study.

Default – The failure of a Party in Breach of this Agreement to cure such Breach under the Small Generator Interconnection Agreement.

Distribution System – The Transmission Provider’s facilities and equipment used to distribute electricity that are not under the operational control of the NYISO, and are subject to the SGIP under FERC Order No. 2006. For the purpose of this Agreement, the term Distribution System shall not include LIPA’s distribution facilities.

Distribution Upgrades – The additions, modifications, and upgrades to the Connecting Transmission Owner’s Distribution System at or beyond the Point of Interconnection to facilitate interconnection of the Small Generating Facility and render the transmission service necessary to effect the Interconnection Customer’s wholesale sale of electricity in interstate commerce. Distribution Upgrades do not include Interconnection Facilities or System Upgrade Facilities or System Deliverability Upgrades.

Energy Resource Interconnection Service – The service provided by NYISO to interconnect the Interconnection Customer’s Small Generating Facility to the New York State Transmission System or Distribution System in accordance with the NYISO Minimum Interconnection Standard, to enable the New York State Transmission System to receive -Energy and Ancillary Services from the Small Generating Facility, pursuant to the terms of the NYISO OATT.

Existing Collection Station – As defined in Attachment 2.

Final Interconnection – Interconnection of the Steel Winds I and Steel Winds II facilities upon completion of installation, testing and commissioning of the System Upgrade Facilities and Interconnection Facilities required to accommodate the Steel Winds II facility, and termination of the Interim Constrained Operation Period.

Force Majeure – Any act of God, labor disturbance, act of the public enemy, war, insurrection, riot, fire, storm or flood, explosion, breakage or accident to machinery or equipment, any order, regulation or restriction imposed by governmental, military or lawfully established

civilian authorities, or any other cause beyond a Party's control. A Force Majeure event does not include an act of negligence or intentional wrongdoing. For the purposes of this Agreement, this definition of Force Majeure shall supersede the definitions of Force Majeure set out in Section ~~2.11~~10.1 of the NYISO Open Access Transmission Tariff.

Good Utility Practice – Any of the practices, methods and acts engaged in or approved by a significant portion of the electric industry during the relevant time period, or any of the practices, methods and acts which, in the exercise of reasonable judgment in light of the facts known at the time the decision was made, could have been expected to accomplish the desired result at a reasonable cost consistent with good business practices, reliability, safety and expedition. Good Utility Practice is not intended to be limited to the optimum practice, method, or act to the exclusion of all others, but rather to be acceptable practices, methods, or acts generally accepted in the region.

Governmental Authority – Any federal, state, local or other governmental regulatory or administrative agency, court, commission, department, board, or other governmental subdivision, legislature, rulemaking board, tribunal, or other governmental authority having jurisdiction over the Parties, their respective facilities, or the respective services they provide, and exercising or entitled to exercise any administrative, executive, police, or taxing authority or power; provided, however, that such term does not include the Interconnection Customer, Erie Wind, NYISO, Affected Transmission Owner, Connecting Transmission Owner or any Affiliate thereof.

Interconnection Customer – ~~Any entity, including the Transmission Owner or any of the affiliates or subsidiaries, that~~ Niagara Wind Power, LLC, which proposes to interconnect its Small Generating Facility (Steel Winds I) with the New York State Transmission System or the Distribution System.

Interconnection Facilities – The Transmission Provider's Interconnection Facilities and the Interconnection Customer's Interconnection Facilities as specified in Attachment 2. Collectively, Interconnection Facilities and Jointly Owned Interconnection Facilities include all facilities and equipment between the Small Generating Facility and the Point of Interconnection, including any modification, additions or upgrades that are necessary to physically and electrically interconnect the Small Generating Facility to the New York State Transmission System or the Distribution System. ~~Interconnection Facilities are sole use facilities and shall not include Distribution Upgrades or System Upgrade Facilities.~~

Interconnection Request – The Interconnection Customer's request, in accordance with the Tariff, to interconnect a new Small Generating Facility, or to increase the capacity of, or make a material modification to the operating characteristics of, an existing Small Generating Facility that is interconnected with the New York State Transmission System or the Distribution System. For the purposes of this Agreement, this definition of Interconnection Request shall supersede the definition of Interconnection Request set out in Attachment X to the NYISO OATT.

Interconnection Study – Any study required to be performed under Sections ~~32.22~~ or ~~32.33~~10.1 of the SGIP.

Interim Constrained Operation – Operation of the wind facilities (Steel Winds I) of the Interconnection Customer and Erie Wind LLC (Steel Winds II) during the Interim Constrained Operation Period such that the combined export of the Steel Winds I and Steel Winds II facilities is limited to a maximum of 10 MW on each of the Connecting Transmission Owner's Lines 149 and 150.

Interim Constrained Operation Period – The Interim Constrained Operating Period will begin upon the Initial Synchronization Date of Erie Wind’s Small Generating Facility. Interim Constrained Operations will terminate upon the earlier of (a) December 31, 2011 or (b) ten (10) business days after the System Upgrade Facilities and Interconnection Facilities are In Service.

Jointly Owned Interconnection Facilities – The interconnection-related facilities jointly owned by Interconnection Customer and Erie Wind, LLC as specified in Attachment 2. Collectively, Interconnection Facilities and Jointly Owned Interconnection Facilities include all facilities and equipment between the Small Generating Facility and the Point of Interconnection, including any modification, additions or upgrades that are necessary to physically and electrically interconnect the Small Generating Facility to the New York State Transmission System or the Distribution System.

Material Modification – A modification that has a material impact on the cost or timing of any Interconnection Request with a later queue priority date.

Minimum Interconnection Standard – The reliability standard that must be met by any Small Generating Facility proposing to connect to the New York State Transmission System or Distribution System. The Standard is designed to ensure reliable access by the proposed project to the New York State Transmission System. The Standard does not impose any deliverability test or deliverability requirement on the proposed interconnection.

New York State Transmission System – New York State Transmission System shall mean the entire New York State electric transmission system, which includes (i) the Transmission Facilities under ISO Operational Control; (ii) the Transmission Facilities Requiring ISO Notification; and (iii) all remaining transmission facilities within the New York Control Area.

Operating Requirements – Any operating and technical requirements that may be applicable due to Regional Transmission Organization, Independent System Operator, control area, or the Connecting Transmission Owner’s requirements, including those set forth in the Small Generator Interconnection Agreement. Operating Requirements shall include Applicable Reliability Standards.

Operational Contact – Shall have the meaning set forth in Section 1.5.7 of this Agreement.

Party or Parties – The ~~NYISO~~, Connecting Transmission Owner, Interconnection Customer, Erie Wind, LLC, or any combination of the above.

Point of Interconnection – The point where the Jointly Owned Interconnection Facilities connect with the New York State Transmission System or the Distribution System.

Reasonable Efforts – With respect to an action required to be attempted or taken by a Party under this Agreement, efforts that are timely and consistent with Good Utility Practice and are otherwise substantially equivalent to those a Party would use to protect its own interests.

Small Generating Facility – The Interconnection Customer’s device no larger than 20 MW for the production of electricity identified in the Interconnection Request, but shall not

include the Interconnection Customer's Interconnection Facilities or the Jointly Owned Interconnection Facilities.

System Deliverability Upgrades – The least costly configuration of commercially available components of electrical equipment that can be used, consistent with Good Utility Practice and Applicable Reliability Requirements, to make the modifications or additions to the existing New York State Transmission System that are required for the proposed project to connect reliably to the system in a manner that meets the NYISO Deliverability Interconnection Standard for Capacity Resource Interconnection Service.

System Upgrade Facilities – The least costly configuration of commercially available components of electrical equipment that can be used, consistent with good utility practice and Applicable Reliability Requirements to make the modifications to the existing transmission system that are required to maintain system reliability due to: (i) changes in the system, including such changes as load growth and changes in load pattern, to be addressed in the form of generic generation or transmission projects; and (ii) proposed interconnections. In the additions to the existing New York State Transmission System that are required for the proposed project to connect reliably to the system in a manner that meets the NYISO Minimum Interconnection Standard.

Tariff – The NYISO's Open Access Transmission Tariff, as filed with the FERC, and as amended or supplemented from time to time, or any successor tariff.

Upgrades – The required additions and modifications to the Connecting Transmission Owner's portion of the New York State Transmission System or the Distribution System at or beyond the Point of Interconnection. Upgrades may be System Upgrade Facilities or System Deliverability Upgrades Distribution Upgrades. Upgrades do not include Interconnection Facilities or Jointly Owned Interconnection Facilities.

**Detailed Scope of Work, Including
Description and Costs of the Small Generating Facility,
Interconnection Facilities, and Metering Equipment**

Equipment, including the Small Generating Facility, Interconnection Facilities, and metering equipment shall be itemized and identified as being owned by the Interconnection Customer, or the Connecting Transmission Owner. The NYISO, in consultation with the Connecting Transmission Owner, will provide a best estimate itemized cost, including overheads, of its Interconnection Facilities and metering equipment, and a best estimate itemized cost of the annual operation and maintenance expenses associated with its Interconnection Facilities and metering equipment.

A. PROJECT DESCRIPTION

Plant Address: 1951 Hamburg Turnpike
 Lackawanna, NY 14218

The Interconnection Customer constructed a 20 MW wind generation facility in the towns of Lackawanna and Hamburg, New York interconnecting to the existing NG-NM Bethlehem Steel 115 kV buses on the Gardenville 149 and 150 Lines via a 115 kV service lateral connection and the existing Station 11A which the Interconnection Customer took ownership of (“Collection Station”).

The Project consists of eight (8) Clipper Liberty 2.5 MW wind turbines operating at 0.690 kV with output stepped up to 13.8 kV through individual pad mount 2.5 MVA transformers. Two 13.8 kV feeders brings the combined power output of the 8 units to the Collection Station where it connects to the 13.8kV side of the transformer TB A1101, is stepped up to 115 kV via the 25/33/41.6 MVA 115/13.8Y kV (11.2% impedance) and 25/33/41.6 MVA 115/13.8Y kV (11.3% impedance) transformers (TB A1101 and TB A1102, respectively), and then brought to the Bethlehem Steel 115 kV bus on the Gardenville 149 and 150 lines. The Collection Station is also used to provide service to Mittal Steel, a load customer of the Connecting Transmission Owner.

The Point of Interconnection (“POI”) for the Project is defined as the Bethlehem Steel 115 kV Bus on the Gardenville 149 and 150 Lines.

B. INTERCONNECTION CUSTOMER’S INTERCONNECTION FACILITIES

The Interconnection Customer constructed the Interconnection Customer’s Interconnection Facilities in accordance with the applicable requirements of Connecting Transmission Owner, to the extent not inconsistent with the terms of this Agreement or the NYISO OATT, and in

accordance with the Connecting Transmission Owner's project specific electrical requirements, to the extent not inconsistent with the terms of this Agreement or the NYISO OATT.

As depicted in Attachment 3, Figures 1 and 2, the Interconnection Customer Interconnection Facilities consist of:

- The Collection Station (Jointly Owned Interconnection Facilities), including:
 - One (1) 13.8 kV, 2500 A bus tie breaker;
 - Relaying;
 - One (1) 3Ph, 75 kVA 13800/480-277V station service transformer;
 - Six (6) 115 kV surge arresters;
 - Two (2) 25/33/41.6 MVA 115/13.8Y kV transformers;
 - Two (2) 13.8 kV, 2500 A breakers;
 - Two (2) 115 kV, 1200A, 550 kV BIL oil circuit breakers;
 - Two (2) 115 kV, 1200A motor operated, oil circuit breaker disconnect switches;
 - Two (2) 115 kV, 1200 A, motor operated line disconnect switches; and
 - Two (2) 115 kV, 1200 A, motor operated tie disconnect switches.

- Equipment in Switchgear, including, but not limited to:
 - Two (2) 13.8 kV, 1200 A feeder breaker;
 - Six (6) 12 kV station class surge arresters;
 - Four (4) sets of single phase, 1200:5 CTs;
 - One (1) set of single phase, 3000:5 CTs;

- Equipment added to the Jointly Owned Interconnection Station as a result of Steel Winds II project interconnection:
 - Interim Constrained Interconnection Period (Attachment 3, Figure 1)
 - Two (2) reverse power relays will be installed by the station owners on the low side of the transformer for limiting the export on each of the Lines 149 and 150 to 10MW or less.

 - Final Interconnection (Attachment 3, Figure 2)
 - One (1) RFL-9745 receiver
 - One (1) RFL IMUX 2000
 - Associatecated switchboard equipment

C. CONNECTING TRANSMISSION OWNER INTERCONNECTION FACILITIES

The Connecting Transmission Owner Interconnection Facilities include:

- One (1) EMS RTU; and
- miscellaneous materials and equipment associated w/ the installation of the metering and RTU.
- Equipment added as a result of the Steel Winds II project interconnection (Attachment 3, Figure 2):
 - Two (2) revenue meter;
 - Six (6) single phase metering Potential Transformers (PTs);
 - Six (6) single phase metering Current Transformers (CTs);
 - Associated materials and equipment for installation of metering.

The Connecting Transmission Owner will supply, install, and test and commission all revenue metering equipment. The CTs and PTs will be installed outdoors in the Collection Station on the 13.8kV structure. The Interconnection Customer will provide and install insulated mounting surfaces for all the units.

D. ESTIMATED COSTS OF INTERCONNECTION FACILITIES

Interconnection Customer Interconnection Facilities 20 MW wind farm generation project and associated equipment required to interconnect to the 115kV Connecting Transmission Owner’s electric system.

\$35,000,000

Interconnection Customer took ownership of the existing Station 11A which is already interconnected to the Connecting Transmission Owner’s 115kV lines 149 and 150.

Interconnection Facilities required to accomodate the interconnection of Steel Winds II facility. (Erie Wind, LLC is responsible for these costs, as defined in the Small Generator Interconnection Agreement between NYISO, National Grid, and Erie Wind, LLC for the Steel Winds II project.)

(Add) INTERCONNECTION CUSTOMER INTERCONNECTION FACILITIES (ICIF)	
Engineering review and compliance verification of the ICIFs and JOIFs, including all required drawing and equipment spec reviews, relay settings, construction and testing assistance by engineers, as applicable	\$59,000
CONNECTING TRANSMISSION OWNER INTERCONNECTION FACILITIES	
Engineering, design, installation, & testing for revenue metering and RTU	\$205,000

All estimated costs include a +/- 25% contingency.

E. O&M EXPENSES FOR INTERCONNECTION FACILITIES

In accordance with Article 4.1 of this SGIA, the Interconnection Customer shall be responsible for all reasonable expenses associated with the operation, maintenance, repair and replacement of the Connecting Transmission Owner’s Attachment Facilities (“O&M Expenses”).

The Interconnection Customer shall have the option to pay such O&M Expenses either under the procedure described in Option 1 or in Option 2 below.

a) Option 1: Fixed On-Going Charge Payment:

The Connecting Transmission Owner will invoice and Interconnection Customer shall pay an annual payment to the Connecting Transmission Owner equal to the product of the Gross Plant Investment associated with the Connecting Transmission Owner Attachment Facility and the Annual Transmission Ongoing Charge Factor, for the term of this Interconnection Agreement.

All payments due to be made by the Interconnection Customer shall be made within thirty (30) days after receiving an invoice from the Connecting Transmission Owner.

The Project's Gross Connecting Transmission Owner's Attachment Facilities Plant Investment cost shall be established in writing by the Connecting Transmission Owner no later than 90 days following commercial operation.

The Annual Transmission On-Going Charge Factor shall be calculated annually each July based on the Company's most recent FERC Form 1 data and will equal the sum of the Revenue Requirement Components as identified in O&M Attachment 1 divided by the Total Gross Plant of the Connecting Transmission Owner. Total Gross Plant shall equal the sum of Item Nos. A (1)(a)(b)(c) in O&M Attachment 1.

b) Option 2: Annual Actual O&M Expenses

The Interconnection Customer shall pay for all actual O&M Expenses incurred by the Connecting Transmission Owner, which expenses shall be billed by the Connecting Transmission Owner quarterly as accumulated during the quarter for which they were incurred.

All payments due to be made by the Interconnection Customer shall be made within thirty (30) days after receiving an invoice from the Connecting Transmission Owner, which invoice shall be issued after the end of each quarter for the most recent quarter.

c) Selection by Interconnection Customer

The Interconnection Customer shall select which option for paying such O&M Expenses by providing written notice to the Connecting Transmission Owner within thirty (30) days after the Gross Connecting Transmission Owner's Attachment Facilities Plant Investment cost and the most recent Annual Transmission Ongoing Charge Factor have been provided to the Interconnection Customer. If the Interconnection Customer fails to provide timely notice to the Connecting Transmission Owner of the option selected, the Interconnection Customer will be deemed to have selected Option 2: Annual Actual O&M Expenses.

O&M ATTACHMENT 1

Capitalized terms used in this calculation will have the following definitions:

Allocation Factors

- (1) General Plant Allocation Factor shall equal Electric General Plant divided by the sum of Electric General Plant plus gas general plant as reported in the Annual Report filed with the New York State Public Service Commission.
- (2) Gross Transmission Plant Allocation Factor shall equal the total investment in Transmission Plant in Service divided by the sum of the total Transmission Plant in Service plus the total Distribution Plant in Service, excluding Intangible Plant, General Plant and Common Plant.
- (3) Transmission Wages and Salaries Allocation Factor shall equal the ratio of Connecting Transmission Owner Transmission-related direct electric wages and salaries including any direct wages or salaries charged to Connecting Transmission Owner by a National Grid Affiliate to Connecting Transmission Owner's total electric direct wages and salaries including any wages charged to Connecting Transmission Owner by a National Grid Affiliate excluding any electric administrative and general wages and salaries.

Ratebase and Expense items

Administrative and General Expense shall equal electric expenses as recorded in FERC Account Nos. 920-935.

Amortization of Investment Tax Credits shall equal electric credits as recorded in FERC Account No. 411.4.

Distribution Plant in Service shall equal the gross plant balance as recorded in FERC Account Nos. 360 – 374.

Electric Common Plant shall equal the balance of Common Plant recorded in FERC Account Nos. 389-399 multiplied by the General Plant Allocation Factor.

General Plant shall equal electric gross general plant balance recorded in FERC Account Nos. 389-399.

Materials and Supplies shall equal electric materials and supplies balance as recorded in FERC Account No. 154.

Payroll Taxes shall equal those electric payroll tax expenses as recorded in FERC Account Nos. 408.100, 408.110 and 408.130.

Prepayments shall equal electric prepayment balance as recorded in FERC Account No. 165.

Real Estate Tax Expenses shall equal electric transmission-related real estate tax expense as recorded in FERC Account No. 408.140 and 408.180.

Transmission Operation and Maintenance Expense shall equal electric expenses as recorded in FERC Account Nos. 560, 562-573.

Transmission Plant in Service shall equal the gross plant balance as recorded in FERC Account Nos. 350-359.

Transmission Revenue Credits shall equal the revenue reported in Account 456.

Transmission Related Bad Debt Expense shall equal Bad Debt Expense as reported in Account 904 related to transmission billing.

Wholesale Metering Cost shall equal any costs associated with any Revenue or Remote Terminal Unit (RTU) meters and associated equipment located at an internal or external tie at voltages equal to or greater than 23V. The cost shall be determined by multiplying the number of wholesale meters in FERC Account No. 370.3 by the average cost of the meters plus the average costs of installation.

In the event that the above-referenced FERC accounts are renumbered, renamed, or otherwise modified, the above sections shall be deemed amended to incorporate such renumbered, renamed, modified or additional accounts.

Revenue Requirement Components

The Revenue Requirement Components shall be the sum of Connecting Transmission Owner's (A) Return and Associated Income Taxes, (B) Transmission Related Real Estate Tax Expense, (C) Transmission Related Amortization of Investment Tax Credits, (D) Transmission Related Payroll Tax Expense (E) Transmission Operation and Maintenance Expense, (F) Transmission Related Administrative and General Expenses, less (G) Revenue Credits, plus (H) Bad Debt Expense.

A. Return and Associated Income Taxes shall equal the product of the Transmission Investment Base as identified in A(1) below and the Cost of Capital Rate.

1. Transmission Investment Base shall be defined as

Transmission Related General Plant plus Transmission Related Common Plant plus Transmission Related Regulatory Assets plus Transmission Related Prepayments plus Transmission Related Materials and Supplies plus Transmission Related Cash Working Capital.

- (a) Transmission Plant in Service shall equal the balance of Total investment in Transmission Plant plus Wholesale Metering Cost.
- (b) Transmission Related General Plant shall equal the balance of investment in General Plant multiplied by the Transmission Wages and Salaries Allocation Factor.
- (c) Transmission Related Common Plant shall equal Electric Common Plant multiplied by the Gross Transmission Plant Allocation Factor and multiplied by the Transmission Wages and Salaries Allocation Factor.
- (d) Transmission Related Regulatory Assets shall equal balances in FERC Account Nos. 182.3 and 254 for state and federal regulatory assets and liabilities related to FAS109, and excess AFUDC multiplied by the Gross Transmission Plant Allocation Factor
- (e) Transmission Related Prepayments shall equal the electric balance of Prepayments multiplied by the Gross Transmission Plant Allocation Factor.
- (f) Transmission Related Materials and Supplies shall equal the balance of Materials and Supplies assigned to Transmission added to the remainder of Material and Supplies not directly assigned to either Transmission or Distribution multiplied by the Gross Transmission Plant Allocation Factor.
- (g) Transmission Related Cash Working Capital shall be a 12.5% allowance (45 days/360 days) of the Transmission Operation and Maintenance Expense (less FERC Account 565: Transmission of Electricity by Others) and Transmission-Related Administrative and General Expense.

2. Cost of Capital Rate

The Cost of Capital Rate shall equal the proposed Weighted Costs of Capital plus Federal Income Taxes and State Income Taxes.

- (a) The Weighted Costs of Capital will be calculated for the Transmission Investment Base using Connecting Transmission Owner's actual capital structure and will equal the sum of (i), (ii), and (iii) below:

- (i) the long-term debt component, which equals the product of the actual weighted average embedded cost to maturity of Connecting Transmission Owner's long-term debt then outstanding and the actual long-term debt capitalization ratio.
- (ii) the preferred stock component, which equals the product of the actual weighted average embedded cost to maturity of Connecting Transmission Owner's preferred stock then outstanding and the actual preferred stock capitalization ratio;
- (iii) the return on equity component, shall be the product of the allowed ROE of 11.9% plus a 50 basis point adder (per FERC Order 697 and 697A) and Connecting Transmission Owner's actual common equity capitalization ratio.

(b) Federal Income Tax shall equal

$$\frac{A \times \text{Federal Income Tax Rate}}{(1 - \text{Federal Income Tax Rate})}$$

where A is the sum of the preferred stock component and the return on equity component, each as determined in Sections 2.(a)(ii) and for the ROE set forth in 2.(a)(iii) above

(c) State Income Tax shall equal

$$\frac{(A + \text{Federal Income Tax}) \times \text{State Income Tax Rate}}{(1 - \text{State Income Tax Rate})}$$

Where A is the sum of the preferred stock component and the return on equity component as determined in A.2.(a)(ii) and A.2.(a)(iii) above and Federal income Tax is determined in 2.(b) above.

B. Transmission Related Real Estate Tax Expense shall equal the Real Estate Tax Expenses multiplied by the Gross Plant Allocation Factor.

C. Transmission Related Amortization of Investment Tax Credits shall equal the electric Amortization of Investment Tax Credits multiplied by the Gross Transmission Plant Allocation Factor.

D. Transmission Related Payroll Tax Expense shall equal Payroll Taxes multiplied by the Transmission Wages and Salaries Allocation Factor.

E. Transmission Operation and Maintenance Expense shall equal the Transmission Operation and Maintenance Expense as previously defined.

F. Transmission Related Administrative and General Expenses shall equal the sum of the electric Administrative and General Expenses multiplied by the Transmission Wages and Salaries Allocation Factor.

G. Revenue Credits shall equal all Transmission revenue recorded in FERC Account 456.

H. Transmission Related Bad Debt Expense shall equal Transmission Related Bad Debt Expense as previously defined.

Figure 2: One-line Diagram Depicting the Small Generating Facility, Interconnection Facilities, Metering Equipment, and Upgrades

(Added) / System Interconnection 07-2010rev1.vsd
 INFORMATION ONLY
 NOT ALL DETAILS SHOWN

Steel Winds II Project One Line Diagram
 (Queue #234) 15 MW Parallel Generation

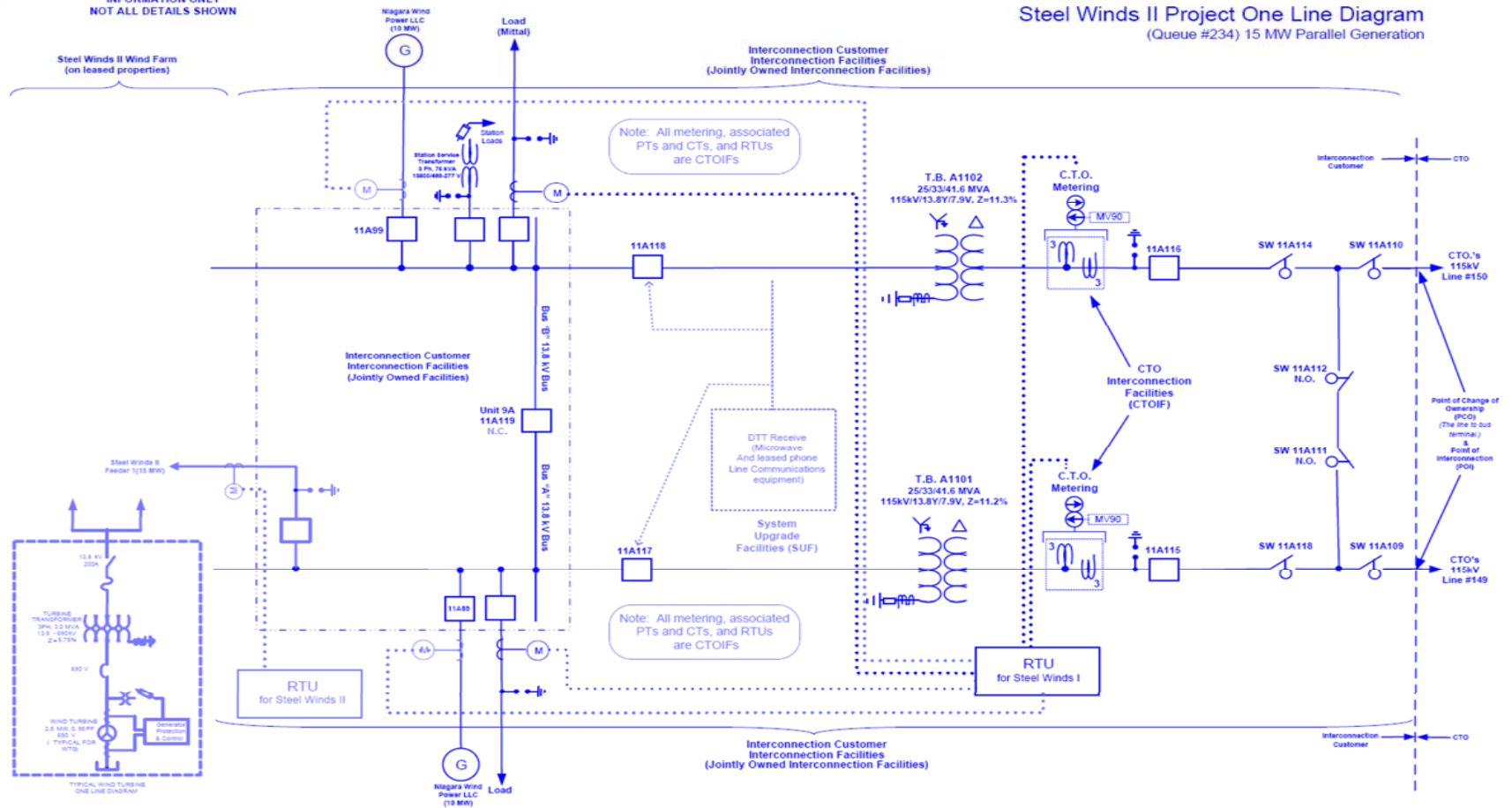

Attachment 4--Milestones

Milestones

The Small Generating Facility (Steel Winds I) was originally interconnected in 2006 under the Original Interconnection Agreement between Niagara Mohawk Power Corporation, d/b/a National Grid and Steel Winds, LLC, dated 2/6/2006. The Milestone Schedule presented below provides the milestones associated w/ the installation of the System Upgrade Facilities and Interconnection Facilities defined within this Agreement and required to accommodate the interconnection of the Steel Winds II facility.

In-Service Date: March 2011 (Interim Constrained Operation Interconnection)
August 2011 (Final Interconnection)

Critical milestones and responsibility as agreed to by the Parties:

(1)	Milestone/Date	Responsible Party
(1)	(2)	
Task	Milestone	Date
Task	Milestone	Date
	Issue written authorization to proceed with engineering, design and procurement	10/1/2010
	INTERIM CONSTRAINED INTERCONNECTION ("ICI")	
		Responsible
		Responsible
1.	Provide detailed electrical design submittal for Interim Constrained Operation Interconnection ("ICOI")	10/15/2010
2.	Provide security pursuant to Section 11.5 of the Interconnection Agreement	10/2010
3.	Review ICOI design and issue comments	11/2010
4.	Submit IFC for ICOI	12/2010
5.	Review IFC for ICOI and issue acceptance an/or comments	12/2010
6.	Start Construction of generation facilities (road and site work, turbines, collection system)	10/2010
7.	Start Construction of Interconnection Facilities	12/2010
8.	Complete Construction of Interconnection Facilities for ICOI	1/2011
9.	Complete Construction of generation facilities	3/2011
10.	Field verification	3/2011
11.	Testing and Commissioning	3/2011
12.	Initial Synchronization	3/2011

(3)- 13. Commercial Operation 3/2011 LLC/Transmission Owner
Erie Wind, LLC

FINAL INTERCONNECTION W/ DTT ("FI")

Task	Milestone	Date	Responsible
1.	Provide detailed electrical design submittal for Final Interconnection ("FI")	12/2010	Erie Wind, LLC
2.	Review FI design and issue comments	1/2011	Transmission Owner
3.	Submit IFC for FI	2/2011	Erie Wind, LLC
4.	Review IFC for FI and issue acceptance an/or comments	2/2011	Transmission Owner
5.	Issue Microwave spec	10/2010	Transmission Owner
6.	Submit GPR data sheet to TO for telecom ckt	10/2010	Erie Wind, LLC
7.	Order telecom ckt	11/2010	Transmission Owner
8.	Provide contractor scope for microwave	12/2010	Erie Wind, LLC
9.	Review, comment and/or accept scope for microwave	12/2010	Transmission Owner
10.	Release PO to contractor	1/2011	Erie Wind, LLC
11.	Complete microwave design and issue to contractor	2/2011	Erie Wind, LLC & Transmission Owner
12.	Contractor IFC received, reviewed and accepted	3/2011	Erie Wind, LLC & Transmission Owner
13.	Microwave installation completed	4/2011	Contractor
14.	Telecom ckt installation completed	4/2011	Verizon
15.	Start Engineering & procurement for SUFs	1/2011	Transmission Owner
16.	Complete Engineering and procurement of SUFs	4/2011	Transmission Owner
17.	Start construction of SUFs	6/2011	Transmission Owner
18.	Complete construction of Interconnection Facilities for FI	7/2011	Erie Wind, LLC
19.	Complete Construction of SUFs	8/2011	Transmission Owner
20.	Functional testing and field verification of ICIFs	8/2011	Erie Wind, LLC
21.	In Service	8/2011	Transmission Owner/Erie Wind, LLC/NYISO
22.	Interconnection Customer testing	9/2011	Erie Wind, LLC
23.	Commercial Operation	9/2011	Erie Wind, LLC
24.	As Built for ICIFs submitted to Transmission Owner	12/2011	Erie Wind, LLC
25.	As Built drawings completed for SUFs	12/2011	Transmission Owner
26.	Project Closeout and final invoicing	2/2012	Transmission Owner

(6)-
(7)-
(8)-

(5)-

~~(9)~~

~~(10)~~

Agreed to by:

For the NYISO _____

Date _____

For the Connecting Transmission Owner _____

Date _____

~~Interconnection Customer~~ ~~Date~~

Interconnection Customer _____

Date _____

Additional Operating Requirements for the New York State Transmission System, the Distribution System and Affected Systems Needed to Support the Interconnection Customer's Needs

The NYISO, in consultation with the Connecting Transmission Owner, shall also provide requirements that must be met by the Interconnection Customer prior to initiating parallel operation with the New York State Transmission System or the Distribution System.

The Interconnection Customer must comply with all applicable NYISO tariffs and procedures, as amended from time to time. The Interconnection Customer must also comply with the Connecting Transmission Owner's operating instructions and requirements as referenced in Sections 1.5 and 1.6 of this SGIA, which requirements shall include equipment outages and control arrangements, tagging agreements and procedures, maintenance arrangements and responsibilities, company contacts and phone numbers and supervisory equipment.

The Interconnection Customer must comply with relevant provisions of the Connecting Transmission Owner's Electric System Bulletins 756, 750-2010, and 755-2003, including appendices, as amended from time to time, to the extent not inconsistent with the terms of this Agreement or the NYISO OATT.

The Interconnection Customer is responsible for correcting any Power Quality or Plant control system performance issues that may arise with the day-to-day system operations.

The Interconnection Customer shall comply with the requirements set forth in Section 1.9 of this Agreement for the duration of the Interim Constrained Operation Period.

Execution of this agreement does not guarantee the deliverability of the full capability of the Project to the transmission system. Prevailing system conditions may, at times, be such that that Project curtailment could be required.

**Connecting Transmission Owner's Description of its Upgrades
and Best Estimate of Upgrade Costs**

The NYISO, in consultation with the Connecting Transmission Owner, shall describe Upgrades and provide an itemized best estimate of the cost, including overheads, of the Upgrades and annual operation and maintenance expenses associated with such Upgrades. The Connecting Transmission Owner shall functionalize Upgrade costs and annual expenses as either transmission or distribution related.

The cost estimate for System Upgrade Facilities and System Deliverability Upgrades shall be taken from the NYISO OATT Attachment S cost allocation process. The cost estimate for Distribution Upgrades shall include the costs of Distribution Upgrades that are reasonably allocable to the Interconnection Customer at the time the estimate is made, and the costs of any Distribution Upgrades not yet constructed that were assumed in the Interconnection Studies for the Interconnection Customer but are, at the time of the estimate, an obligation of an entity other than the Interconnection Customer.

The cost estimates for Distribution Upgrades and System Upgrade Facilities and System Deliverability Upgrades are estimates. The Interconnection Customer is ultimately responsible for the actual cost of the Distribution Upgrades and System Upgrade Facilities and System Deliverability Upgrades needed for its Small Generating Facility, as that is determined under Attachments S and X and Z of the NYISO OATT.

A. DISTRIBUTION UPGRADES

~~**Attachment 7 – Insurance Coverage**~~

~~Effective Date: 6/30/2010~~

No Distribution Upgrades are required for the Small Generating Facility.

B. SYSTEM UPGRADE FACILITIES

System Upgrade Facilities required to accommodate the interconnection of Steel Winds II:

i) Gardenville Substation

Dual channel direct transfer trip (“DTT”) will be installed between Gardenville Substation and the Existing Collection Station. This will include:

- One (1) new RFL 9745 transmitter;
- One (1) 4-wire type A phone circuit from Gardenville Substation to the Existing Collection Station, and associated equipment;
- One (1) RFL IMUX-2000;
- One (1) microwave antenna;
- Harrison True Point microwave radio;
- Multiconductor cable;
- RFL tone equipment and multiplexers for microwave communications equipment;
- and
- Associated power supplies, conduit, etc for the DTT.

The Connecting Transmission Owner is responsible for all System Upgrade Facilities at Gardenville Substation.

ii) Collection Station

- One (1) microwave antenna;
- Harrison True Point microwave radio;
- Two (2) telecommunications racks;
- One (1) RFL IMUX-2000;
- Additional Positron shelf for telecommunications circuits;
- RFL tone equipment and multiplexers for microwave communications equipment;
- and
- Associated power supplies, conduit, etc for the DTT.

-
-

Engineering design, procurement, installation and testing responsibilities are defined in the Small Generator Interconnection Agreement between NYISO, National Grid, and Erie Wind, LLC for the Steel Winds II project.

C. Estimated Cost of System Upgrade Facilities

System Upgrade Facilities at the Jointly Owned Interconnection Station required to accommodate the interconnection of Steel Winds II facility. (Erie Wind, LLC is responsible for all applicable costs, as defined in the Small Generator Interconnection Agreement between NYISO, National Grid, and Erie Wind, LLC for the Steel Winds II project.)

(Add)

SYSTEM UPGRADE FACILITIES	
Engineering, Design, and construction of modifications and/or additions to the telecommunications and protective relaying at, and/or between, the Jointly Owned Interconnection Station and Gardenville station (including radio network between the stations and the 4-Wire analog circuit)	
JOINTLY OWNED INTERCONNECTION STATION	\$483,000

GARDENVILLE SUBSTATION	\$554,000
SUF SUBTOTAL	\$1,037,000

Insurance Coverage

Interconnection Customer shall, at its own expense, maintain in force throughout the period of this Agreement, the following minimum insurance coverage, with insurers authorized to do business in the State of New York:

Commercial General Liability Insurance including, but not limited to, bodily injury, property damage, products/completed operations, contractual and personal injury liability with a combined single limit of \$1 million per occurrence, \$2 million annual aggregate.